



DRAFT ENVIRONMENTAL IMPACT STATEMENT

**IT'S GREENER NOW, INC
PADUA RIDGE GRAVEL MINE
TOWN OF DIX
SCHUYLER COUNTY, NEW YORK**

Lead Agency:

New York State Department of Environmental Conservation
Region 8 Headquarters
6274 E. Avon - Lima Road
Avon, New York 14414
Contact Person: Tom Haley, Region 8 (585) 226-5393

Applicant:

It's Greener Now, Inc
3362 Route 409
Watkins Glen, New York 14891

Preparer:

JMT of New York, Inc.
19 British American Boulevard
Latham, New York 12110
(518) 782-0882

Project No.: 16-S0157N-001

Submitted: July 11, 2022

Lead Agency Acceptance: July 11, 2022

Public Hearing: _____

Comments Period: _____

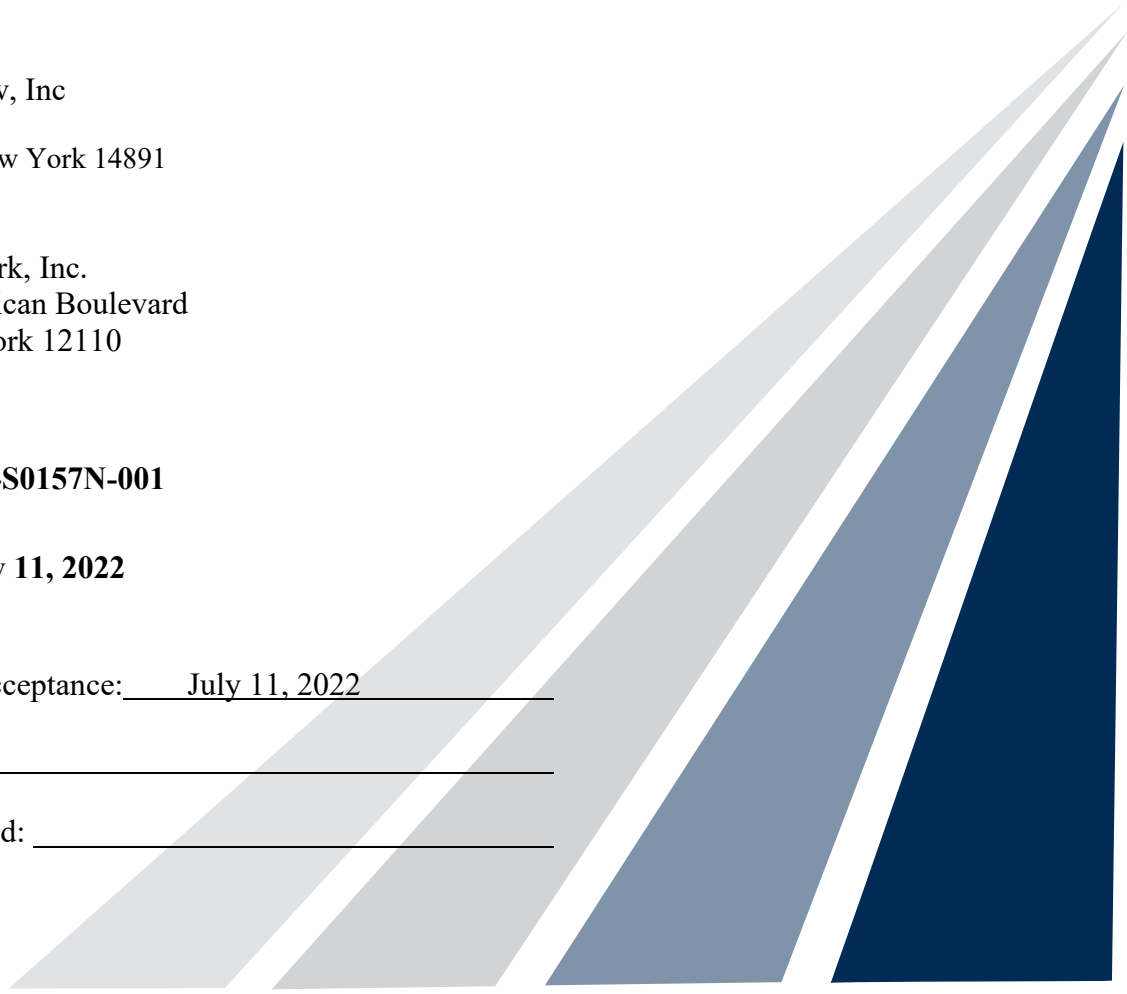



TABLE OF CONTENTS

1.0	EXECUTIVE SUMMARY INTRODUCTION	1
1.1	PROJECT DESCRIPTION	1
1.2	EXECUTIVE SUMMARY.....	2
	1.2.1 POTENTIALLY SIGNIFICANT BENEFICIAL AND ADVERSE IMPACTS AND PROPOSED MITIGATIONS	3
	1.2.2 SUMMARY OF ALTERNATIVES CONSIDERED	6
	1.2.3 ISSUES OF CONTROVERSY	8
	1.2.4 INVOLVED AGENCIES	8
	1.2.5 INTERESTED AGENCIES.....	9
1.3	PURPOSE AND NEED FOR PROPOSED ACTION.....	9
2.0	ENVIRONMENTAL REVIEW PROCESS	9
2.1	UNIFORM PROCEDURES REGULATIONS.....	9
2.2	STATE ENVIRONMENTAL QUALITY REVIEW.....	10
2.3	EIS SCOPING PROCESS	10
2.4	OPPORTUNITIES FOR PUBLIC COMMENT	11
3.0	UNAVOIDABLE ADVERSE IMPACTS.....	11
3.1	NATURAL RESOURCES.....	11
	3.1.1 Geology.....	11
	3.1.2 Ecological Resources.....	11
	3.1.3 Visual Resources	12
	3.1.4 Noise	12
4.0	ENVIRONMENTAL SETTING, IMPACTS AND MITIGATION	13
4.1	GEOLOGY, SOILS AND TOPOGRAPHY	13
	4.1.1 Existing Environmental Setting.....	13
	4.1.2 Potential Impacts	16
	4.1.3 Proposed Mitigation Measures	17
4.2	SURFACE WATER RESOURCES.....	17
	4.2.1 Existing Environmental Setting.....	17
	4.2.2 Potential Impacts	19
	4.2.3 Mitigation and Stormwater Management	20



4.3	GROUND WATER RESOURCES	20
4.3.1	Existing Environmental Setting.....	21
4.3.2	Potential Impacts	23
4.3.3	Proposed Mitigation Measures	24
4.4	ECOLOGICAL RESOURCES	25
4.4.1	Existing Environmental Setting.....	25
4.4.2	Potential Impacts	26
4.4.3	Proposed Mitigation Measures	27
4.5	VISUAL AND AESTHETIC RESOURCES.....	27
4.5.1	Existing Environmental Setting.....	27
4.5.2	Inventory of Aesthetic Resources	28
4.5.3	Potential Impacts	28
4.5.4	Proposed Mitigation Measures	31
4.6	NOISE	31
4.6.1	Existing Environmental Setting.....	32
4.6.2	Potential Impacts	32
4.6.3	Proposed Mitigation Measures	33
4.7	CULTURAL RESOURCES	34
4.7.1	Existing Environmental Conditions	34
4.7.2	Potential Impacts	35
4.7.3	Mitigation Measures	35
5.0	ALTERNATIVES TO THE PROPOSED ACTION.....	35
5.1	NO ACTION ALTERNATIVE	35
5.2	ALTERNATIVE SITES	36
5.3	ALTERNATIVE SIZE	36
5.4	ALTERNATIVE DESIGN AND/OR TECHNOLOGIES	37
5.4.1	Site Design.....	37
5.4.2	Operational Practices	38
5.5	ALTERNATIVE LAND USE.....	38
5.6	ALTERNATIVE DEVELOPMENT SCHEDULE.....	38
6.0	LIST OF APPLICATION DOCUMENTS.....	39



TABLES

TABLE 1	MONITORING WELL DATA
TABLE 2	INVENTORY OF AESTHETIC RESOURCES

FIGURES

FIGURE 1	SITE LOCATION
FIGURE 2	BEDROCK GEOLOGY
FIGURE 3	SURFICIAL GEOLOGY
FIGURE 4	SOIL MAP
FIGURE 5	WETLANDS
FIGURE 6	LOCATION MAP – INVENTORY OF AESTHETIC RESOURCES

SHEETS

SHEET 1	MINE PLAN MAP
SHEET 2	RECLAMATION PLAN
SHEET 3	FINAL GRADE PROFILES
SHEET 4	BEDROCK ELEVATION
SHEET 5	OVERBURDEN GROUNDWATER CONTOURS
SHEET 6	BEDROCK GROUNDWATER CONTOURS
SHEET 7	GEOLOGIC CROSS SECTIONS
SHEET 8	LINE OF SITE PROFILE LOCATIONS
SHEET 9	LINE OF SIGHT PROFILES

APPENDICES

APPENDIX A	USFWS ECOLOGICAL RESOURCE DOCUMENTATION
APPENDIX B	GEOLOGIC LOGS
APPENDIX C	NEW YORK NATURAL HERITAGE PROGRAM DOCUMENTATION
APPENDIX D	NOISE PROJECTION ANALYSIS
APPENDIX E	GROUNDWATER MONITORING WELL DATA (ON CD)
APPENDIX F	MINED LAND USE PLAN
APPENDIX G	STORMWATER POLLUTION PREVENTION PLAN
APPENDIX H	NYSDEC DEIS FINAL SCOPING OUTLINE
APPENDIX I	VISUAL ASSESSMENT PHOTOGRAPHIC LOG
APPENDIX J	WGSP HYDROGEOLOGIC AND ECOLOGIC DOCUMENTATION
APPENDIX K	NYS OFFICE OF PARKS CORRESPONDENCE
APPENDIX L	ENVIRONMENTAL ASSESSMENT FORM (EAF)



1.0 EXECUTIVE SUMMARY INTRODUCTION

It's Greener Now, Inc. (IGN) currently owns and operates a sand and gravel mining operation in the Town of Dix, Schuyler County, known as the Padua Ridge Gravel Mine (MLF # 80244) (the "Padua Ridge Mine"). IGN seeks a modification of its Mined Land Reclamation Law (MLRL) permit (8-4424-00006/00001) for the Padua Ridge Mine to add 60.95 +/- acres to the currently approved 14.33 acre Affected Area boundary. Such modification, if granted, will bring the total Life-of-Mine Affected Area to 75.28 +/- acres on properties comprising approximately 281 acres.

This Draft Environmental Impact Statement (DEIS) has been prepared to assess the potential environmental impacts associated with this proposed modification in accordance with a Final Scoping Outline dated August 18, 2008 (Appendix H). Since the Final Scoping Outline was issued, the proposal has been revised to further mitigate or eliminate potential environmental impacts. These revisions include elimination of a proposed material transport tunnel under NYS Route 409, elimination of a proposed rail siding, a reduction in the Life-of-Mine affected area and a reduction in the depth of mining to eliminate any mining below the local seasonal groundwater table.

1.1 PROJECT DESCRIPTION

The Padua Ridge Gravel Mine is located on properties comprising approximately 281± acres (the "IGN Property") and is located along Route 409 in the Town of Dix, Schuyler County, New York. Figure 1, "Site Location Map," illustrates the location of the mine site and its relationship to the surrounding area. The mine site is bound by NYS Rte. 409 on the west, the lands of Watkins Glen State Park on the southwest, and the lands of St. Mary's Cemetery to the southeast.

IGN proposes to add 60.95 +/- acres to the currently approved 14.33 acre Affected Area boundary, to bring the total Life-of-Mine Affected Area to 75.28 +/- acres. The mine is intended to continue to operate as a traditional surface extraction of unconsolidated sand and gravel and will not involve removal of consolidated bedrock or below-water-table operations.

The modification to expand the Life-of-Mine ("LOM") Affected Area from the currently approved 14.33 acres to ±75.28 acres will not result in a significant change from previously permitted historic operations. While the overall acreage of the mine will increase over the life of the project, the total disturbed area (active mining excavation area, previously mined unreclaimed areas, and processing areas) will be minimized by employing concurrent reclamation practices and by limiting stripping activities in advance of mining. The additional acreage to be included in the LOM Affected Area is currently predominantly used as agricultural livestock pasture.



In addition to these areas, affected acreage at the facility has historically included an office and scale house which will continue to be a part of the operation. Concurrent reclamation will be performed throughout the life of the operation to control the number of affected acres. As operations progress, there will not be a significant increase in the mine's production rate. The existing mine area currently abuts the Watkins Glen State Park property and will continue to do so as the mine expands. However, as operations expand, mining excavation operations will be moving further away from the Watkins Glen gorge. The expanded LOM area will serve to increase the available sand and gravel reserves.

Mining is not proposed below the local seasonal high-water table. Excavation will be performed by mechanical equipment, standard for sand and gravel mining operations. Mining is proposed to remove approximately 3.5 million cubic yards of sand and gravel over the estimated 20-year operational LOM. Mined material will continue to be processed with screening, washing, and crushing equipment. Sorted aggregate will be stockpiled in locations as indicated in the Mined Land Use Plan (Appendix F). The maximum processing rate for the screening and washing plant is 560 tons per hour, and for the crushing plant is 290 tons per hour. Actual production will remain subject to market demand. Final reclamation of the site will include grading and sloping of all mine faces, the replacement of stockpiled soils, and re-seeding with an appropriate seed mixture. The proposed LOM area is 75.28 acres. Hours of operation are proposed to remain the same as present: from 6:00AM to 8:00PM, Monday through Saturday.

The proposed action is a revision to an existing application to expand the mine. The previous version of the application included a material transport tunnel underneath NYS Route 409, a rail siding for loading of rail cars for transport to market, a larger proposed LOM Affected Area, and greater depth of mining. The current version of the proposal eliminates the tunnel and rail siding and reduces the lateral area and depth of mining from the original proposal. These revisions result in a reduction or elimination of some potential environmental impacts and permitting requirements in comparison to the original version of the proposal.

1.2 EXECUTIVE SUMMARY

This report is a Draft Environmental Impact Statement (DEIS) that has been prepared to satisfy the requirements of the State Environmental Quality Review Act (SEQRA) for the proposed action as identified herein.

This DEIS has been prepared in accordance with 6 NYCRR 617.9(b) to address those potential impacts identified in the Final Scoping Outline for Preparation of a Draft Environmental Impact Statement (DEIS), dated August 18, 2008 (Appendix H). In general, these are potential impacts to: geologic resources, ecological resources, water resources, visual resources, and cultural (historic and



archaeological) resources. This DEIS evaluates the likelihood and significance of these potential environmental impacts and outlines mitigation measures, where appropriate.

1.2.1 POTENTIALLY SIGNIFICANT BENEFICIAL AND ADVERSE IMPACTS AND PROPOSED MITIGATIONS

The layout and design of the Proposed Action is such that any possible adverse environmental impacts will be minimized to the greatest extent that is reasonably practicable.

There will be a significant and positive effect on local and regional economies. Construction aggregates are the most basic of resources, required for infrastructure, commercial, industrial, and residential projects. The implementation of the Project will ensure continued competition in the aggregate market. The availability of aggregate material at an affordable and competitive price is important to the economy of the entire community and region.

There will be minor adverse impacts to some natural resources including geologic, ecological, and water resources. There will be impacts to such human resources as visual resources.

Mitigation measures proposed to minimize the potential for impacts associated with continued operation and the expansion of the mine include activities specifically undertaken by IGN to minimize or eliminate potential impacts and project planning that, by its nature, serves as pre-mitigation by design. Among these are revisions to the proposal to eliminate a proposed material transport tunnel under NYS Route 409, eliminate a proposed rail siding, reduce the LOM Affected Area and reduce the depth of mining to eliminate any mining below the local seasonal groundwater table.

1.2.1.1 Geology and Water Resources

Extraction of sand and gravel for use in the construction industry constitutes the removal of an abundant, non-renewable geologic resource. Mining activity will not intercept the groundwater table and will not pose any impacts to buried gorges or groundwater resources. Buried gorges, if present, will not be impacted by extraction of overlying unconsolidated deposits and, in any event, do not present a unique or sensitive geologic resource.

The excavation of unconsolidated sand and gravel above the groundwater table poses no impacts to groundwater resources or adjacent groundwater wells. IGN will implement the procedures outlined in the SWPPP developed for the site to ensure stormwater is properly managed. This should prevent site runoff and run-on from adjacent properties and maintain high quality waters within the mine site and its vicinity at both the surface and ground level.



To minimize erosion of surficial deposits and soils on-site, only enough area to accommodate approximately one year's mining ahead of the active quarry area will be stripped at any time. Reclamation of mined areas will take place, to the greatest extent possible, concurrent with mining, to reduce the amount of land surface exposed at any given time. To prevent off-site migration of sediment-laden water to nearby surface waters, stormwater practices and erosion and sediment controls will be implemented as detailed in the attached Stormwater Pollution Prevention Plan (SWPPP). (See Appendix G.)

1.2.1.2 Visual Resources

The site is an existing sand and gravel mine and is generally well-screened by topography and vegetation from potential visual receptors. Worst-case scenario simulations demonstrate limited impacts in leaf-off conditions at a minimum number of potential receptors. Particular attention was paid to the views from four locations identified on NYS Routes 414 and 79 by the Schuyler County Environmental Management Council. These included the view from the southeast end of Seneca Lake, the view from the curb at Clute Park, the view from the northeast corner of 4th and Porter Streets in Watkins Glen, and the view just south of the Village of Burdett before descending the hill to the southeastern village limits of Watkins Glen.

No significant impacts to visual resources are anticipated, as a result of the Padua Ridge Gravel Mine Expansion project.

1.2.1.3 Ecological Resources

Existing wildlife habitat is limited across the mine site. Available databases were researched, and applicable agencies were contacted for ecological information within the nearby state-owned lands of Watkins Glen State Park, Watkins Glen (Glen Creek) Gorge, and in the general area of the project, including the mine site itself.

No records of sensitive ecological resources were identified within the project area.

Within Watkins Glen State Park, the U.S. Fish and Wildlife Service identified: one threatened plant species (Leedy's Roseroot, *Rhodiola integrifolia* spp. *Leedyi*); nine (9) migratory birds; and nine (9) federal wetlands, that may have the potential to be affected by certain activities within or adjacent to the State Park. No critical habitat with the potential to be affected by the project was identified by U.S. Fish and Wildlife Service.

Also, within Watkins Glen State Park, the NY Natural Heritage Program (NYNHP) acknowledged the potential for occurrence of one special concern animal species: Gray Petaltail, *Tachopteryx thoreyi* and



identified three (3) significant natural communities: Calcareous Shoreline Outcrop, Hemlock-Northern Hardwood Forest, and Shale Cliff and Talus Community. (See Appendix C for NYNHP correspondence.)

Additionally, according to the New York State Office of Parks, Recreation, and Historic Preservation (NYS Office of Parks), a significant threat to Watkins Glen State Park ecology is the invasive insect, Hemlock Woolly Adelgid (HWA), which kills hemlock trees. The eastern hemlock (*Tsuga canadensis*), which can be found throughout the park, is an important part of the park's ecosystem, as it provides essential habitat to a plethora of plants and wildlife. Efforts have been made throughout the park in recent years to combat the invasive insect species, including applying treatments to trees and monitoring the insects.

It is not anticipated that the mining expansion will exacerbate the invasive species issue, as it is not expected to impact the existing ecology of the park.

As mining practices are anticipated to remain the same, the proposed expansion is not likely to have any adverse effects on these ecological resources.

1.2.1.4 Cultural Resources

There are no identified cultural or historical resources at the mine site. The adjacent Watkins Glen State Park is eligible for listing on both the National and State Registries of Historic Places. It is not anticipated that the proposed mine expansion will adversely impact the eligibility of the park or have the potential to impact the Park's cultural characteristics which qualify it for eligibility.

The proposed project is also adjacent to portions of the National Register-listed Watkins Glen Grand Prix Road Course (Course). The Course is a historic Grand Prix auto racetrack over public rights of way. The original 6.6-mile track was used from 1948 to 1952 and was listed on the National Register of Historic Places in 2002. An initial consultation submission was made on October 24, 2017, to NYS Office of Parks for their review and determination of potential impacts to the nearby historical and cultural resources. Office of Parks responded on November 20, 2017, with a request for additional information regarding potential visual and aesthetic impacts to a 0.5-mile portion of the Course which borders the IGN Property along NYS Route 409. JMT prepared a response letter, dated April 23, 2019, to satisfy their request. Subsequently, the Office of Parks issued a letter on May 23, 2019, determining that the response resolved their concerns regarding the project's potential impact on the Road Course.

It should also be noted that the Office of Parks issued an additional letter on July 2, 2019, regarding items separate from that of the Road Course, including items outside of the approved DEIS scoping



outline for the project. IGN addressed this letter in a response, dated September 1, 2021. In response, the OPRHP issued a findings letter on December 10, 2021 which agreed with the IGN assessment of no impact affirming, “*It is the opinion of OPRHP that the project will have No Adverse Impact on historic resources*”.

More detailed discussions of potential impacts to the Course and other historic resources are contained within Sections 4.5 and 4.7.

1.2.1.5 Noise

Potential impacts to noise were not identified as an area of concern in the final scoping outline. However, due to changes in scope and proposed grading, a new noise impact assessment was completed. The proposed action has the potential to marginally raise sound levels in close proximity to the site, with sound levels at two selected receptors potentially increasing by up to 4.5 dB(A). Per NYSDEC’s program policy Assessing and Mitigating Noise Impacts, this represents an unnoticeable to tolerable increase in observable sound levels. Existing and proposed screening berms and best management practices adequately mitigate potential noise impacts. No additional mitigation is required.

1.2.2 SUMMARY OF ALTERNATIVES CONSIDERED

Alternatives to the "Proposed Action" with respect to location, size, design, technology, land use, and development schedule were evaluated. The "No Action" alternative, meaning that the proposed mining expansion would not be implemented, was also considered.

No Action Alternative

The site is an existing sand and gravel mine, and environmental impacts from the existing site would remain under the “No Action” alternative. Although the "No Action" alternative would not increase environmental impacts, including those to natural resources, visual and aesthetic resources, noise, and traffic, it would incur several disadvantages.

The "No Action" alternative's disadvantages include:

- Failure to provide economic growth and development at the local and regional levels;
- Failure to provide needed aggregate resources to local and regional markets consistent with the stated objective of the Mined Land Reclamation Law;
- Failure to create jobs;



- Failure to provide vitally needed State-approved aggregate materials to local and regional markets; and
- Failure to process locally available mineral resources that are needed by the construction industry in Schuyler County and other counties in the area.

Alternative Sites

The project site is the only site in the immediate market area that possesses both the quality and quantity of material necessary to be able to supply, for the long term, approved materials meeting New York State Department of Transportation (NYSDOT) specifications. IGN does not own or control additional properties that have the available construction aggregates reserves needed to meet DOT specifications and meet the needs of the community and market area.

Alternative Size

The project location is an existing sand and gravel mine. Although expansion of the existing operation has the potential to result in environmental impacts, alternate scales of expansion do not have proportionately larger or smaller environmental impacts than those associated with the proposed project. However, alternate scale does have a significant impact on the viability of the operation and the local economic impact.

Additionally, the original application to expand the permitted LOM area incorporated a design that sought to achieve reclamation grades of substantially greater depth than what is currently being proposed and included an associated tunnel and rail-siding for rail shipment of material. Revisions to the proposed mining and final reclamation plans have been made to incorporate an expanded understanding of site geologic and hydrogeologic conditions, and to minimize potential environmental impacts. Currently proposed final grades ensure that excavation will not intercept the local groundwater regime. The current proposal represents an alternative project scale and configuration to what was originally proposed.

Alternative Design and/or Technologies

The proposed site layout maximizes potential geologic reserves while minimizing potential environmental impacts. Alternative designs would affect the economic feasibility of the project and potential to impact environmental resources.



To mine unconsolidated materials, there are few alternatives to the industry-standard mechanical equipment. Only this equipment offers the mobility, speed and maneuverability required for the type of operations proposed.

Alternative Land Use

The proposed land use at cessation of mining is vegetated open space, consistent with the currently approved reclamation objective and with surrounding land uses. Alternative land uses were considered and deemed infeasible due to the mine plan and/or economic considerations.

Alternative Development Schedule

The rate of extraction of sand and gravel from the mine site is governed by market demand and does not significantly impact the total magnitude of potential environmental impacts over the life of the mine. Alternative development schedules are not an effective or practical method of mitigating potential impacts.

1.2.3 ISSUES OF CONTROVERSY

Issues of controversy for the proposed action have been identified in the Final Scoping Outline. Issues of controversy common to aggregate mining include public perception and aesthetic impacts, environmental and ecological impacts, cultural resource impacts, economic impacts, traffic and roadway impacts, and project alternatives. In proximity to the proposed action, Watkins Glen State Park/Glen Creek Gorge and the Watkins Glen Grand Prix Road Course have been identified as significant potentially sensitive receptors.

This EIS evaluates these issues in detail, as identified in the Final Scoping Outline and subsequent studies and correspondence.

1.2.4 INVOLVED AGENCIES

The following is a list of agencies having approval authority over the action:

- New York State Department of Environmental Conservation for the Mined Land Reclamation Permit (ECL 23-2701), SPDES Permit (ECL 17-0801);
- New York State Office of Parks Recreation and Historic Preservation for cultural and historic places review and determination (Parks Recreation and Historic Preservation Law Article 14); and
- Town of Dix for Special Use Permit and Site Plan Approval.



1.2.5 INTERESTED AGENCIES

While no approvals are required from the following agencies, the proposed action may include submissions for review from:

- Mine Safety Health Administration (MSHA) for the regulation of mine safety (30 USC 811, 957, 961); and
- The Seneca Nation of Indians.

1.3 PURPOSE AND NEED FOR PROPOSED ACTION

As reserves in the current LOM are depleting, expansion is warranted to allow for the continued supply of construction aggregate materials to be used by nearby villages, towns, counties, cities, State and Federal contractors, manufacturers, schools, retailers, other contractors, and homeowners. A consistent supply of aggregate material is necessary to provide affordable products for the community and region.

The demand for construction aggregates is expected to grow steadily. This anticipated growth is based on an anticipated comparable growth in commercial services such as retail businesses, hotels, restaurants, and residential communities, the construction of which requires large amounts of aggregate. Additionally, the resurfacing and reconstruction of existing roadways in Schuyler County will necessitate a viable and economically competitive aggregate mining industry.

Construction aggregates are among the most basic of resources. The implementation of the proposed action will foster competition in the aggregate market. The availability of aggregate materials at an affordable and competitive price is important to the economy of the entire community and region.

2.0 ENVIRONMENTAL REVIEW PROCESS

The following sections are derived directly from the NYSDEC DEIS Final Scoping Outline (Appendix H).

2.1 UNIFORM PROCEDURES REGULATIONS

In New York State, processing of environmental permit applications is regulated by 6 NYCRR Part 621, Uniform Procedures Regulations. The intent of the Uniform Procedures Regulations is to ensure timely review of projects requiring multiple environmental permits. Projects subject to the State Environmental Quality Review Act (SEQRA) regulations must satisfy these requirements before permit applications reviewed under Part 621 are deemed complete. When the NYSDEC as the lead agency determines that a



DEIS is required by the applicant, the scoping, review, and acceptance of the DEIS are considered a prerequisite to a complete permit application.

2.2 STATE ENVIRONMENTAL QUALITY REVIEW

SEQRA requires the governmental bodies undertaking or approving an action to include consideration of environmental impacts in their decision-making process. SEQRA further requires that government agencies minimize and avoid significant adverse environmental impacts to the maximum extent practicable, given the reasonable range of alternatives and consideration of social, economic, and other essential factors.

If an action is determined to have a potentially significant adverse environmental impact, then SEQRA requires an Environmental Impact Statement (EIS) to be prepared to assess the impact and identify practicable means, if any, to avoid or mitigate it. This requirement can be found in Environmental Conservation Law sections 3-0301(1)(b), 3-0301(2)(m) and 8-0113, and 6 NYCRR Part 617. The EIS process is designed so that the government body undertaking or approving the action will examine how it can avoid or minimize significant adverse environmental impacts. The EIS should concisely describe and analyze the proposed action and must be made available to the public for review and comment. Generally, the EIS must include: a description of the action, including its need and benefits; a description of the environmental setting and areas to be affected; an analysis of all significant environmental impacts related to the action; an analysis of reasonable alternatives to the action; and an identification of ways to reduce or avoid significant adverse environmental impacts.

When an action consists of several steps or sets of related activities, the entire set must be considered the action, even if several separate governmental bodies are involved. An action should not be segmented into its different components, as this would be contrary to the intent of SEQRA. Lastly, no agency involved in the overall action can make a final decision, by undertaking, funding, or approving any part of the action, until the SEQRA process is complete.

2.3 EIS SCOPING PROCESS

The primary goals of scoping are to focus the DEIS on potentially significant adverse impacts and to eliminate consideration of those impacts that are irrelevant or non-significant. The scoping process establishes the contents of a DEIS, and the lead agency provides the public the opportunity to participate in that process. The final scoping document is completed after consideration of all substantive comments from the public and involved agencies.



The Final Scoping Outline issued by NYSDEC for this proposed project can be found in Appendix H. As some additional information has become available since the Scoping Outline was issued, and as the proposed project has been reduced in magnitude, some additional subjects are included within this DEIS that were not included in the Scoping Outline. These subjects include an expanded discussion of cultural resources and potential noise impacts.

2.4 OPPORTUNITIES FOR PUBLIC COMMENT

In addition to seeking public input on its scope, the DEIS, when completed and accepted by NYSDEC, will be made available for public review and comment. A Public Hearing will be held by the NYSDEC to receive public comment on the DEIS. A final EIS will then be prepared to address all substantive comments received. The DEIS and supporting documents will be available in an electronic format and posted on the web to enable public review.

3.0 UNAVOIDABLE ADVERSE IMPACTS

3.1 NATURAL RESOURCES

3.1.1 Geology

The construction aggregates underlying the site will be removed for use by the construction industry to meet the needs of the communities nearby. Because they are a non-renewable resource, once they are removed, they will no longer be retrievable. This commitment of resources will provide construction material for use in local projects and will foster and facilitate economic development, thereby furthering local and regional goals. Soils on the site may experience minor adverse impacts due to the effects of mining.

3.1.2 Ecological Resources

The proposed mine expansion will result in the temporary removal of some vegetation and habitat. As there are no known occurrences of rare, threatened, or endangered species on-site, it is not anticipated that any of these species will be affected. The microclimate phenomenon of nearby Watkins Glens State Park will not be impacted by the project as proposed in the Mined Land Use plan and related SWPPP. As with the current operations, the proposed expansion will implement good housekeeping practices to ensure the integrity of stormwater discharges and mitigate any potential impacts to nearby ecological resources.



3.1.3 Visual Resources

There will be some minor impacts to visual resources, but none is considered to be significant. Some distant vantage points will have views of the mine's additional affected area. However, views of the mine site from sensitive receptors will not significantly differ from existing conditions. Visibility of the current affected area will not change. As shown by the Line-of-Sight drawings (See Sheets 8 and 9), the majority of receptors already have a view of the current affected area. The proposed expansion will not alter this. For the most part, the views of the proposed expansion area will be obstructed by the existing affected area. The expanded mine will not be visible from Watkins Glen State Park, the Watkins Glen Grand Prix Course, or other aesthetic resources. (See Section 4.5 below.).

3.1.4 Noise

Noise levels off-site will be comparable to ambient levels as discussed in Section 4.6. Once mining is completed, noise levels will be unaffected. Mitigation measures included in the mining plan to minimize noise and reduce impacts offsite include:

1. All equipment is to be muffled to meet MSHA standards;
2. Portable processing facilities will be strategically placed to take full advantage of existing topographic barriers and to-be-constructed mine faces; and
3. Natural barriers created by the active mine faces and additional screening berms as described in Section 4.6 will act to reduce noise levels when equipment is operating.

All plant employees and equipment operators will be instructed in the operation of equipment to reduce noise. Below is a list of techniques that will be employed at the site to reduce noise:

4. Employees will be instructed in the proper operation and maintenance of all equipment;
5. Employees will be instructed not to "race" the engines of any equipment;
6. Employees will be instructed to report any operating irregularities in equipment that may increase the level of noise generated by that equipment;
7. Vehicle speeds will be controlled to reduce engine noise during transport of material; and
8. All plant equipment will be properly maintained and secured.



4.0 ENVIRONMENTAL SETTING, IMPACTS AND MITIGATION

This section describes the environmental setting of the proposed project. Potential impacts of the proposed project are identified and evaluated below. Where applicable, this section also includes proposed measures to mitigate unavoidable short-term, long-term, and/or cumulative impacts.

4.1 GEOLOGY, SOILS AND TOPOGRAPHY

4.1.1 Existing Environmental Setting

The Padua Ridge mine site is located within the Town of Dix, Schuyler County, New York. It is geographically situated southwest of the southern end of Seneca Lake, within the Allegheny Plateau province.

4.1.1.1 Regional Bedrock Geology

The Padua Ridge site is underlain by Devonian sedimentary rocks deposited in a warm tropical sea which covered what is now central New York. The Devonian rocks include alternating sequences of shales, siltstones, and sandstones from the Hamilton Group and the Genesee Group. The bedrock within this region has been subjected to minor tectonic deformation resulting in very low amplitude folds, several minor faults and two sets of joints.

There are no bedrock exposures within the current mine area. There are abundant bedrock exposures adjacent to the site in all directions, most notably Watkins Glen gorge, which is located less than a quarter mile south of the mine.

4.1.1.2 Regional Surficial Geology

Before the Pleistocene glaciations, a relatively flat landscape was formed traversed by north-south trending river valleys. During pre-glacial times, the rivers of south-central New York flowed north through a series of river valleys. Most tributaries to these rivers flowed from the west or east forming a branching network of streams. This entire network is buried by glaciolacustrine, glaciofluvial and later Quarternary deposits, (Cadwell, *et al.*, 1987).

During glaciation, ice completely covered Schuyler County during the later stages of the Wisconsin period (23,000 to 13,500 years age). The advancing ice sheet stripped away pre-glacial deposits and weathering products. The glacial sediments lie directly on the bedrock surface. The advancing ice sheets flowed southward, parallel but opposite to the river flow, gouging deep trenches into the river valleys.



As the ice sheet receded, flows of meltwater carried away gravel and sand. These sand and gravel deposits can be found today within the valleys of south-central New York. Ice sheets carved deep trenches into the previously existing river valleys, creating large glacial lakes. Meltwater from ice sheets, runoff from precipitation and groundwater fed these glacial lakes, later providing a continuous source of water to the lakes after the glacial ice had retreated. Deltaic deposits developed along the perimeters by tributaries flowing into the lakes from the surrounding hillsides.

Lodgement till comprises about half of the glacial deposits within Schuyler County and is interspersed with glacial kame and kame moraine deposits, moraine deposits, glacial outwash deposits and lacustrine silt and clays. Lodgement till is comprised of material that was deposited at the base of the ice sheet under pressure of the overlying ice as it moved over the land surface. The lacustrine silts and clays of Schuyler County are primarily located along the southern rim of Seneca Lake and represent material deposited along the bottom of the lake during a time of higher water level following the retreat of glacial ice.

According to the Surficial Geologic Map of New York (Appendix B), the glacial deposits on the site are comprised of both lodgement till and lacustrine silts and clays. However, it should be noted that this map is generalized and does not always accurately reflect geologic deposits at a smaller scale.

4.1.1.3 Site Geology

The east-west trending Watkins Glen gorge, eroded by stream action during interglacial periods, was filled with glacial deposits during glacial advances. As the ice retreated northward through the main Seneca Valley, higher water levels within paleo Seneca Lake temporarily “dammed” the Watkins Glen Creek. As a result, a delta was formed as sediment from the creek was deposited into the lake along the steep valley walls. As the water level within the lake lowered, the Watkins Glen Creek began to erode the deltaic deposits, which were then deposited onto the main valley floor. These deposits form the foundation of the Village of Watkins Glen.

The Padua Ridge Gravel Mine lies within the deltaic deposit associated with deposition by the Watkins Glen Creek into paleo Seneca Lake. The topographic expression of the delta is still visible today.

Several geologic investigations have been completed on the site, including an additional drilling investigation completed in 2017 as specified in the Scoping Outline. Results from this investigation can be found within the geologic logs included as Appendix B. As evidenced on Sheets 4 and 7, based on empirical site data from these geologic investigations, the bedrock interface slopes generally from southwest-to-northeast, away from Watkins Glen State Park and the Glen Creek gorge. Historic and recent drilling and surface evidence indicate an inflection point or bedrock ridge separating the mine site



property and Watkins Glen State Park to the south. Overlying the bedrock is a layer of dense, low-permeability glacial till and clay deposits, which ranges in depth from 70 ft to 2 ft thick. Above this till layer is a deposit of glacial outwash sand and gravel materials which vary in size and permeability with depth and location.

Previous correspondence from USGS have posited the potential for the existence of buried gorges underlying the site, which would have the potential to hydrologically connect the mine site with the Watkins Glen State Park/Glen Creek gorge. Buried gorges, or paleo-gorges, are bedrock channels associated with glacial geology and are filled with glacial deposits (e.g., lodgement or outwash deposits). Significant investigation activities have been completed over the history of the mine site in attempt to better define site geology and hydrogeology, and to identify any potential buried gorges. Significantly, additional drilling was conducted in 2017, in accordance with the Final Scoping Outline. Evidence from prior investigations and from the 2017 geologic drilling investigation does not indicate the existence of such a buried gorge. To the contrary, subsequent investigations have continued to confirm and refine the understanding of the bedrock surface and groundwater regime within the site. As discussed in Section 4.3, all evidence to date indicates that the overburden groundwater regime within the IGN site is hydrologically isolated from the Watkins Glen State Park/Glen Creek gorge. Bedrock and groundwater elevations, as determined by direct observation, are depicted on Sheets 4 through 7. Additional geologic and groundwater data can be found in Table 1 and Appendices B and E.

4.1.1.4 Soils

The soils on the property consist of several members of the Howard, Lordstown-Arnot, Schoharie, and Valois Series. The proposed LOM Affected Area nearly exclusively includes members of the Howard series. This deep, nearly level to steep soil is typically found in glacial outwash plains, kames and eskers with a high content of sand and gravel. The soil mainly consists of gravelly loam, very gravelly loam, and very gravelly silt loam. The soils are primarily derived from sandstone and siltstone with some limestone and shale (see Figure 4).

Soils within the proposed LOM Affected Area are not agriculturally important soils. The United States Department of Agriculture (USDA) has assigned Land Use Capability Classifications for site soils only in irrigated conditions (no classification is made in non-irrigated condition). Capability Class designations for site soils include Classes 2, 3, and 4, indicating moderate to severe limitations for use in agriculture, and requiring special planning, conservation, and management practices for planted crops. All site soils are also included in subclass e or s, indicating susceptibility to erosion and/or additional rooting zone limitations, respectively. Best agricultural uses for predominant site soils would include pasture, range, and timber/forestland. Portions of the site are currently utilized for livestock pasture.



4.1.2 Potential Impacts

The proposed expansion includes the continuation of extraction and processing for sale of non-renewable sand and gravel geologic material. The excavation of sand and gravel for use in the construction industry will result in the loss of this non-renewable resource for future use. The sand and gravel material that is present at the site is common throughout the state and represents a functionally unlimited resource. As a result, no significant impacts to surficial geology will result from bedrock extraction at the site.

The Reclamation Plan Map (Sheet 2) and Final Grade Profiles (Sheet 3) illustrate the proposed final slope configuration of the site. Final topography will be excavated and graded to observe regulatory setbacks and estimated groundwater elevations. All setbacks have been designed to meet or exceed NYSDEC standards. The outer perimeter of the mine floor and all slopes will remain setback from the property line a distance of at least 1.5 times the vertical face height plus 25 feet, at a minimum. For the majority of the site (adjacent to Watkins Glen State Park, nearby residences, NYS Route 409, and steeper slopes to the east), enhanced setbacks are proposed. The proposed project includes a minimum 50-foot setback along the southwestern border with Lands of New York State (Watkins Glen State Park), the northwestern border with NYS route 409, and an adjacent residential property to the north. Due to limited marketable reserves along the eastern margins of the property, proposed setbacks to the east are on the order of hundreds of feet. Taken together, these setback and slope standards will ensure mine face stability.

The chief potential impact on geology and soils as a result of unconsolidated material excavation is often the potential for erosion of surficial materials within the Affected Area Boundary. This may occur where existing vegetation and associated root systems are removed. Agriculturally important soils are not present at the site, therefore, there will be no impacts to agriculturally important soils.

In accordance with the MLUP, overburden and soils will be stripped and stockpiled on site for use in reclamation activities. In an effort to prevent off-site migration of surficial geologic material and soils, and in accordance with standard practices, stripping activities will be limited to accommodate active mine production and appropriate erosion and sediment controls will be utilized in disturbed areas. Stripped materials will be stored on-site for future use in reclamation. As a result, there will be minimal impact to surficial geology and soils from operation of the mine site.

Buried Gorges

As stated above, extensive geologic investigations have provided no evidence to suggest the existence of a buried gorge or system of gorges beneath the mine site. Even if one were to exist, however, it would



not be impacted by mining activities at the site. The material subject to mining is defined by the geologic and hydrogeologic investigations to date, and as illustrated on Sheets 2 and 3, based upon the material's physical properties and site hydrogeologic conditions. These factors are consistent across the site, as depicted on the attached sheets, irrespective of the shape of the underlying bedrock surface. Surface drainage patterns will not be significantly altered, with precipitation that falls on the site and infiltrates the ground continuing to enter the groundwater regime as it currently does, resulting in no significant perturbations to the site groundwater regime. As the seasonal high groundwater table remains well above the bedrock interface, and the water table will not be intercepted by mining activities, there is no potential to impact the geology or hydrogeology of any potential buried paleo gorges.

4.1.3 Proposed Mitigation Measures

Extraction of sand and gravel material for use in the construction industry constitutes the removal of an abundant, non-renewable resource and requires no additional mitigation.

To minimize erosion of the limited surficial deposits and soils on-site, only enough area to accommodate approximately one year's mining ahead of the active quarry area will be stripped at any time. Stripped overburden and soil materials will be stored for use in reclamation. Reclamation of mined areas will take place to the greatest extent possible concurrent with mining to reduce the amount of land surface exposed at any given time. A SWPPP (Appendix G) has been prepared for the site and outlines those practices that will be employed to minimize soil and subsoil erosion. No additional mitigation is required.

4.2 SURFACE WATER RESOURCES

The surface topography of a region determines the location and prominence of surface water divides and basins in that area. A common surface water divide is a topographic peak that separates distinct regions of surface water flow. When water (as precipitation) falls on the land surface, it flows down slope if it is not first lost to: a) infiltration; or b) evapotranspiration, and eventually joins surface water bodies (e.g., streams, lakes, and ponds). From topographic highs, such as ridgelines, water flows downhill on either sides of the high. Topographic highs, therefore, serve as surface water divides.

4.2.1 Existing Environmental Setting

Regional and Local Surface Water Resources

Located in the Allegheny Plateau in western Schuyler County, the local topography of the Town of Dix is characterized by numerous creeks, streams, lakes, and ponds. Several surface water bodies of significant interest, located closest to the Padua Ridge Gravel Mine site, are described below.



Glen Creek

The Glen Creek flows in an easterly direction (from Sugar Hill State Forest into Seneca Lake) approximately 300-500 feet southeast of the Padua Ridge property, where it exhibits a water quality classification of B. The best usages of Class B waters are primary and secondary contact recreation and fishing. These waters are also suitable for fish, shellfish and wildlife propagation and survival.

Quarter Mile Creek

Quarter Mile creek flows in an easterly direction from near Van Dyke Road in the Town of Dix, into Seneca Lake in the Village of Watkins Glen. Quarter Mile Creek is located approximately 700 feet north of the mine site and runs through a portion of other lands of IGN, located across NYS Route 409 to the west of the mine site and proposed expansion. Quarter Mile Creek is a Class C stream. The best usage of Class C waters is fishing. These waters are suitable for fish, shellfish and wildlife propagation and survival. The water quality is suitable for primary and secondary contact recreation, although other factors may limit the use for these purposes.

Seneca Lake

Seneca Lake is located approximately one mile northeast of the mine site property at an elevation of 445 feet amsl. With a water quality classification of B(T) in the vicinity of the site, Seneca Lake is suitable for primary and secondary contact recreation and fishing, and for fish, shellfish, and wildlife propagation and survival. Seneca Lake provides significant recreational and commercial opportunities, as well as ecological resources.

Although the Seneca Lake Inlet, the drainage sub-basin where the Site is located, is not designated class “AA,” certain sections of Seneca Lake further north (located in the Seneca/Big Stream sub-basin) are so designated and are highly valued, because they are a source of water supply for drinking. The Best Management Practices (BMPs) and procedures described within the attached SWPPP (Appendix G) will ensure the integrity of stormwater discharges at the facility and mitigate any impacts to the class “AA” waterbody/watershed north of the Site.

Site Surface Water Resources

There are several man-made water bodies within the Padua Ridge mine site and proposed expansion area. These water bodies are illustrated on the Mine Plan Map (Sheet 1) and include existing settling/stormwater ponds that serve the mining operation, as well as two agricultural ponds. One of these man-made agricultural ponds is incorrectly mapped as a Freshwater Forested/Shrub Wetland (See



Figure 5). This +/- 0.25-acre pond was created for agricultural purposes, is isolated from any other surface water bodies, and provides minimal ecological benefit.

Several springs are also located on the mine site property (see Sheet 1). Springs are surface expressions of groundwater. Water emanating from on-site springs typically flows a short distance to the east before infiltrating the ground and rejoining the groundwater regime. Springs in the eastern portion of the property produce water that continues to flow down the steeper sloped, less well-drained soils/till, and/or enter the Village of Watkins Glen Drainage Easement. Groundwater springs are discussed further in Section 4.3.

Site surface water runoff from precipitation events and surface water discharge from springs flow according to topographic conditions, generally from southwest-to-northeast, ultimately leading towards Seneca Lake. The project area boundary (proposed LOM) along the southeast portion of the site roughly follows a ridgeline which serves as a surface drainage divide. There is no significant surface water contribution from the project area to Watkins Glen State Park and/or the Glen Creek drainage.

4.2.2 Potential Impacts

Expansion of the existing mine site has the potential to temporarily increase sediment mobilization by stormwater. Potential stormwater impacts are discussed further in Section 4.2.3 and in the attached SWPPP (Appendix G). Any such impacts will be mitigated as described therein.

The proposed modification includes a reconfiguration of the existing man-made stormwater ponds and removal of the existing man-made agricultural ponds. These existing man-made ponds do not provide significant ecological or hydrological value, and their reconfiguration and/or removal is not considered a significant impact.

Expansion of the existing mine site will result in minor alterations to internal surface drainage patterns. However, overall site drainage patterns will be consistent with existing conditions. Stormwater runoff and surface water discharges will continue to move across the site from southwest to northeast and will infiltrate the ground as groundwater recharge through the mine floor and/or the stormwater management area(s). The proposed project will not alter surface water contributions to groundwater or to Watkins Glen State Park and/or the Glen Creek Gorge.

Comments received on the NYSDEC draft scoping document identified potential local concerns regarding perceived recent increases in flooding related to groundwater seeps and springs to the northeast and east of the mine site. For the reasons discussed above, the proposed expansion will not impact these groundwater resources, nor does it have the potential to increase (or reduce) groundwater



discharge rates observed at off-site springs and seeps. Any spring-related flooding is contingent upon ambient groundwater conditions and/or excessive discharge of groundwater from spring locations, which will be unaffected by the proposed expansion. Groundwater impacts are discussed in Section 4.3.2.

4.2.3 Mitigation and Stormwater Management

A Stormwater Pollution Prevention Plan (SWPPP) has been prepared for the site and is included as Appendix G. The SWPPP includes an analysis of potential stormwater generated on-site, treatment design calculations, permanent stormwater controls, and erosion and sediment controls. Prior to initiation of mining activity, IGN will file a Notice of Intent to Discharge for coverage under NYSDEC SPDES Multi-Sector General Permit (GP-0-17-004).

The provisions included in the SWPPP will prevent any potential impact to off-site water bodies from site-generated stormwater.

There are no other potential impacts to surface water resources that require mitigation.

4.3 GROUND WATER RESOURCES

Similar to surface water, the surface topography of a region often largely determines the location and prominence of groundwater divides and basins in that area. A common groundwater divide is a topographic peak which acts as a recharge boundary by separating distinct regions of surface water flow and infiltration or recharge. Precipitation that infiltrates groundwater from topographic highs, such as ridgelines, flows down-gradient from either side of the recharge boundary (i.e., the topographic high). Topographic highs, therefore, often serve as surface corollaries for groundwater divides. Groundwater continues to flow down-gradient until it (typically) encounters a discharge point into a water body or at the surface as a groundwater spring or becomes sequestered in a deep isolated aquifer.

Groundwater elevations are typically represented as potentiometric surfaces. Potentiometric surfaces represent the hydrostatic pressure associated with an aquifer. In the case of confined aquifers, potentiometric surfaces can often exist above the elevation of the water-bearing formation(s), and associated water levels in groundwater monitoring wells will be consistent with the potentiometric surface. Monitoring points that exhibit this condition are considered to be artesian. Measured artesian conditions are frequently, but not always, a good indicator of a confined (i.e., locally hydrogeologically isolated) aquifers. The condition often results when recharge areas for a confined aquifer are located at greater elevation than the measuring point.



4.3.1 Existing Environmental Setting

Regional and Local Hydrogeology

The regional hydrogeology is dominated by the Seneca Lake Basin. The Seneca Lake Basin is a classic example of a hill-valley groundwater flow system. In general, groundwater recharge is accomplished by the infiltration of precipitation to the water table at high elevations on or near the topographic divides. Limited recharge may also occur on the steep side slopes of the valley at intermediate elevations. However, the steep topography of the valley sidewalls generally promotes runoff and overland flow of precipitation.

Groundwater discharges to both the deeply incised stream gorges on the sides of the valley and beneath Seneca Lake in the valley center. Within a hill-valley flow system, the depth to water is greatest beneath high-elevation recharge areas. In contrast, depth to water is shallowest near discharge zones in topographic low regions. The water table intercepts Seneca Lake at an elevation of roughly 445 feet above mean sea level. An unconfined flow system in the glacial overburden follows local topography toward gullies incised in the valley walls or flows downslope and discharges into the lake.

Bedrock groundwater dynamics follow similar patterns. However, due to the steep valley side slopes, potentially remote recharge areas, and often low-permeability confining layers (e.g., clays, tills, some rock formations), bedrock groundwater often occurs under confined conditions and can exhibit artesian characteristics.

Site Hydrogeology

The Padua Ridge mine site is situated at the crest of the Seneca Lake valley slope. Groundwater on the site has been defined by construction and observation of monitoring points (groundwater wells) and observation of both on-site and nearby springs as well as nearby water features, including water features to the north and east, and to the south within Watkins Glen State Park. Observed groundwater elevations across the site range from approximately 814 feet amsl to the east, to approximately 947 feet amsl to the southwest, as reflected in Table 1 and on Sheets 5 through 7. Table 1: Groundwater Well Data Summary, also includes seasonal high and low groundwater elevations for each monitoring point determined from monitoring well transducer data collected in 2017. This additional groundwater monitoring data is included in Appendix E.

The site and surrounding property also include the locations of several groundwater springs. Springs are surface expressions of groundwater and often occur where geologic interfaces encounter the surface



topography. In the case of the Padua Ridge mine site, surface springs appear to be coincident with surface expressions of the upper geologic till and/or clay interface which overlies bedrock.

The existence of significant low-permeability clays and tills overlying bedrock, as discussed in Section 4.1, indicates that the groundwater regime in the unconsolidated material is isolated from the bedrock groundwater regime. The difference in shape between the two observed groundwater regimes, as shown on Sheets 5 through 7, and the flattened shape of the bedrock groundwater potentiometric surface further support this conclusion.

Site groundwater elevations generally mimic ground- and bedrock-surface contours. Groundwater elevation and flow direction across the site is generally from the southwest to the northeast, away from Watkins Glen State Park and towards Seneca Lake. This is consistent with typical hill-valley groundwater regimes. Expression of the bedrock groundwater potentiometric surface at elevations above the bedrock interface, as shown in monitoring well data and on Sheets 6 and 7, indicate confined, artesian conditions. This further indicates that the unconsolidated, “shallow” groundwater regime is isolated from the bedrock groundwater regime.

Watkins Glen State Park Seeps and Microclimates

Watkins Glen State Park contains Glen Creek and the associated Watkins Glen Gorge. Along the rim of the gorge, and along the bedrock walls within the gorge at various elevations, groundwater seeps into the gorge proper. Within the gorge, these seeps often produce microclimates and associated ecological communities that are unique to gorge ecosystems. (See Appendix J.) Seep locations, microclimates and potential impacts to ecological resources are further discussed in Section 4.4.

Seeps along the rim of the gorge are springs (surface expressions of groundwater) that appear to occur where the glacial till or clay surface encounters the ground surface. These springs indicate there is a shallow groundwater flow gradient component into the gorge. This is consistent with the local topography, which includes a topographic high-point and recharge boundary to the north, at a distance of a few hundred feet from the rim of the gorge, between the gorge and the Padua Ridge mine site. This recharge boundary hydrogeologically isolates the “shallow” gorge-rim seeps (till-associated groundwater springs) from the groundwater regime of the mine site. From the north side of the topographic ridge, where the Padua Ridge mine site is located, precipitation infiltrates the groundwater regime and continues to flow north and east across the mine site toward Seneca Lake. From the south side of the topographic ridge, precipitation infiltrates the groundwater regime and continues to flow south and east toward the gorge.



Bedrock groundwater seeps in the gorge walls occur at various elevations deep within the gorge (see Appendix J). This phenomenon is consistent with typical groundwater discharge behavior in bedrock walls or faces and is similar to what occurs at bedrock quarry faces. Bedrock groundwater encountering a steep, exposed face presents itself as a “seepage face.” Seepage face dynamics are governed by bedrock hydraulic conductivity and result in a groundwater potentiometric surface cross-sectional shape similar to a cone of depression from a pumped groundwater well. Groundwater levels are steeply depressed as they near the face. Evidence of this is clear when comparing the bedrock potentiometric elevations of the Padua Ridge mine site with the elevations of bedrock seeps within the gorge. This likewise establishes that the bedrock groundwater regime at the mine site and in the surrounding area is functionally isolated from the overburden or shallow groundwater regime by overlying low-permeability glacial till and/or clay, as well as by the relatively low-permeability of the bedrock itself.

Another way to think of this dynamic is that bedrock-based gorge seepage faces are significantly lower in elevation than the till-associated gorge rim springs. The groundwater supplying the gorge rim springs therefore must be unavailable to recharge the bedrock groundwater regime due to the low permeability of either the intervening till and clay deposits, or of the bedrock formation itself. The conclusion best supported by the gorge seep evidence, as well as site hydrogeologic evidence, is that the unconsolidated deposits (sand and gravel) subject to mining are hydrogeologically isolated from the underlying bedrock.

4.3.2 Potential Impacts

Surface mining in general has the potential to affect surface drainage patterns, and therefore infiltration rates and location and magnitude of groundwater recharge. However, the proposed excavation and final grading plans will not significantly alter surface drainage patterns or infiltration locations at the Padua Ridge mine site and vicinity. Surface runoff will continue to infiltrate the mine floor and/or stormwater ponds, and groundwater in the vicinity of the site will continue to flow from southwest to northeast. There will be no significant potential impacts to groundwater resulting from the proposed expansion of the existing excavation. This lack of potential impact is applicable to both high- and low-water conditions, as the water table itself will not be encountered or impacted by mining activity. The magnitude of potential impact does not change under drought or flood conditions.

The proposed expansion is a continuation of existing excavation activities and will not encounter or significantly perturb unconsolidated or consolidated groundwater regimes. Any minor potential impacts to rates or location of groundwater infiltration that may have the potential to occur would be located north of the groundwater recharge divide (topographic ridge) which separates the mine site from Watkins Glen State Park. Recharge areas for groundwater seeps and associated microclimates within Watkins Glen State Park are located off of, and hydrogeologically isolated from, IGN Property and the geologic material proposed for mining, and accordingly will not be impacted by the proposed expansion.



The proposed expansion has no potential to impact the quality or quantity of groundwater available to Watkins Glen State Park or to surrounding groundwater users. Furthermore, because the proposed expansion has no potential to impact these resources, there will be no impact to the micro-climate experienced by gorge visitors, even during drought conditions.

Springs on the IGN Property are associated with the surface expression of the glacial till interface, which is not a material of interest to IGN for mining. Furthermore, springs are surface-expressions of groundwater and therefore coincident with groundwater elevations. As the proposed expansion does not include any excavation below groundwater, and as till material is of limited market viability, the spring locations are not included within mining excavations and will not be impacted by the proposed expansion.

4.3.3 Proposed Mitigation Measures

The proposed Padua Ridge mine site will not result in impacts to groundwater resources, Watkins Glen State Park groundwater seeps, or nearby groundwater users, and as such, no additional mitigation measures are warranted. However, given the availability of established groundwater monitoring locations, and consistent with the Scoping Document, IGN will continue to monitor on-site groundwater wells for the duration of mining. Groundwater measurements will be recorded once per quarter, and records will be maintained on-site. Groundwater monitoring records will be made available to NYSDEC upon request. The following wells will be subject to this groundwater monitoring program:

MW-1-17
MW-2-17
MW-3-17
MW-4-17
MW-5-17
EW-1S
EW-1D
EW-2D
B-1S
B-2D



4.4 ECOLOGICAL RESOURCES

4.4.1 Existing Environmental Setting

Existing wildlife habitat is limited across the site. The site includes an active mine site and agricultural lands. The operation and phasing of the project have been designed to minimize any potential impacts to wildlife. The amount of area stripped of vegetation at any one time will be limited to the area needed to accommodate approximately one year's mining, leaving the remainder of the mine site available for wildlife habitat. Concurrent reclamation practices will minimize long-term impacts to wildlife habitat.

Available databases were researched, and applicable agencies were contacted for ecological resource information pertaining to the nearby state-owned lands of Watkins Glen State Park and Watkins Glen gorge to assess any potential impacts the action may have on these resources.

On August 16, 2021, the U.S. Fish and Wildlife Service Information for Planning and Consultation Online System (IPaC) did not identify the mine site or the state-owned lands as having any critical habitat. (See Appendix A for a copy of the official IPaC Species Report and related information.) One threatened species, a flowering plant, Leedy's Roseroot, *Rhodiola integrifolia* spp. *Leedyi*. was identified as having the potential to be affected by activities in the general area.

The New York Natural Heritage Program (NYNHP) has acknowledged the potential for one special concern species within the boundaries of Watkins Glen State Park -- a dragonfly species known as Gray Petaltail (*Tachopteryx thoreyi*).

Additionally, the following natural communities within Watkins Glen State Park are considered significant from a statewide perspective by the NYNHP:

- Calcareous Shoreline Outcrop - The outcrop is large and sparsely vegetated within a 700-acre natural area that is surrounded by agriculture. The community has several exotic species whose spread may be somewhat controlled by repeated, seasonal scouring.
- Hemlock-Northern Hardwood Forest - This is a medium-sized, mature forest community with an 18-acre patch of old growth in good condition within a predominately agricultural landscape. A few exotic species are present, but not widespread within the community.
- Shale Cliff and Talus Community - This is a large, shaded calcareous shale cliff and talus community that lines a deep gorge and is within a 700-acre natural area that is surrounded by agriculture. The cliff varies from approximately 15 to 120 feet (4 to 40 meters) in height and is associated with a broad band of talus shale along much of its length. Exotic species are present, but not particularly abundant on the cliff face or in the talus.



See Appendix C for a copy of the NYNHP correspondence.

According to the NYNHP, in New York State, the Gray Petaltail dragonfly is found mostly in rocky gorges and glens, consistent with the natural conditions of the nearby Watkins Glen State Park and Glen Creek gorge. Additionally, the NYNHP website (<http://www.acris.nynhp.org/guide>) lists Hemlock-Northern Hardwood Forests -- a significant natural community present in Watkins Glen State Park -- as an associated ecological community. Threats to the species include any impacts to changes in natural hydrology (i.e., through dams, logging, etc.), dissolved oxygen content, use of pesticides as well as contamination from runoff or agricultural discharge. Intentional killing by humans is also listed as a potential threat. (NY NHP, Aug. 2017)

The NYNHP associates Leedy's Roseroot with Shale Cliff and Talus Communities, another natural community present within Watkins Glen State Park. According to the NYNHP, threats to the plant species include encroachment from other vegetation.

Appendix J contains documentation on the locations of several seep- or spring-associated ecologic communities of potential interest.

4.4.2 Potential Impacts

As the site will continue to implement the same mining practices that currently exist, it is not anticipated that the mine expansion will have any significant adverse impacts on ecological resources, including the three natural communities, the Watkins Glen Gorge microclimates, Leedy's Roseroot, and the dragonfly species.

The affected area includes the land cover type of agriculture (livestock pasture). Wildlife is limited across the site and no sensitive species are known to occur on-site. There is no potential to significantly impact wildlife on the site property as a result of the proposed action.

The site is bound by additional agricultural lands, a few residences, and by upland deciduous forested areas. These areas will not be subject to mining activities. Consequently, ground disturbance within the proposed affected area will not significantly impact existing wildlife at adjacent properties.

As is the case with any type of development, potential impacts from general site development (i.e., stripping and clearing of vegetation) include stormwater and erosion, which have the potential to affect nearby properties, if not properly managed and maintained. However, potential impacts will be minimal with the implementation of applicable environmental plans and management practices.



As discussed in Section 4.3, the proposed expansion has no potential to impact groundwater quality or quantity available to gorge communities.

4.4.3 Proposed Mitigation Measures

As discussed above, the proposed project has been designed to minimize any potential impacts to wildlife. A majority of the proposed expansion area is agricultural lands (livestock pasture). The amount of area stripped of vegetation at any one time will be limited to the area needed to accommodate approximately one year's mining, leaving the remainder of the mine site available for wildlife habitat. Soil and overburden materials will be stockpiled for use in reclamation activities. Concurrent reclamation will be completed to the extent practicable by reclaiming areas of the site as they reach final grades.

Mining activities as proposed will minimize the amount of habitat disturbed at any one time. Reclamation will occur, when applicable, as excavation of each mined area is complete.

As stated above, potential impacts will be minimal with the implementation of appropriate environmental plans and management practices. Specifically, a SWPPP (see Appendix G) has been developed to minimize sediment and other pollutants in stormwater discharges. Appropriate stormwater management, including the best management practice of good housekeeping, will be implemented to ensure the integrity of stormwater discharges and mitigate any potential impacts to the ecological conditions of nearby properties.

Although the NYNHP as well as the most recent USFWS IPaC search (Appendix A) did not identify the Indiana bat or any other endangered or threatened bat species, seasonal restrictions to any tree removal with a diameter greater than 3-inches DBH will be implemented. Furthermore, if any identified threatened or endangered species (e.g., Leedy's Roseroot) is encountered or observed, an in-place procedure to immediately "stop work" will be followed until the appropriate actions are taken.

No additional mitigation is warranted.

4.5 VISUAL AND AESTHETIC RESOURCES

4.5.1 Existing Environmental Setting

The Padua Ridge mine site is located in central Schuyler County, Town of Dix, north of Watkins Glen State Park. The site is located in a moderately sloped, rural area characterized by agriculture and mixed forest.



Views of the mine site property are generally limited by the existing vegetation and intervening topography. Unscreened views of the mine site are generally from the east and at significant distance (i.e., from the eastern slopes of the Seneca Lake Basin valley). Potential impacts to views of the site are discussed below.

4.5.2 Inventory of Aesthetic Resources

An inventory of aesthetic resources within a 5-mile radius has been developed in accordance with the NYSDEC Program Policy: Assessing and Mitigating Visual and Aesthetic Impacts (DEP-00- 2). The inventory of aesthetic resources includes resources of statewide importance within the 5-mile radius, such as: national, state, and municipal parks, national wildlife/state game refuges, nature/historic preserve areas as well as listings on the National Register of Historic Places. The resource inventory is attached as Table 2, Inventory of Aesthetic Resources. A corresponding figure depicting the location of each resource is provided as Figure 6, Location Map – Inventory of Aesthetic Resources. A summary of the resources is presented below in section 4.5.3.

4.5.3 Potential Impacts

To assess potential visual impacts of the proposed project, JMT conducted a topographic and vegetative cover-based sight line assessment from representative residential and/or publicly accessible vantage points located within the general area. Significant topographic and vegetative screenings protect the project location from view from all directions except the east and northeast. Impacts to views from likely accessible locations from the east and northeast, will not differ significantly from existing views, as the current affected area is already visible to some extent.

Appendix I, Visual Assessment Photographic Log, comprising photographs collected on June 12 and 13, 2017 includes views along five (5) line-of-sight profiles discussed below, as well as views from several other publicly accessible locations within the viewshed. In addition to numerous supplemental viewpoints, the visual assessment incorporates four locations specifically referenced in the Scoping Document. The following table summarizes these specific vantage points on line-of-sight profiles (Sheet 9 of 9):

<u>Location</u>	<u>Applicable View Points and Photographs</u>
NYS Route 414: Southeast end of Seneca Lake	Profile D-D': Vantage Point 13; Photos 1, 3, 4, 11
Clute Park	Profile B-B': Vantage Point 5; Photos 2, 7
Northeast Corner of 4 th and Porter Streets	Profile D-D': Vantage Point 12; Photo 4
Route 79: Just South of the Village of Burdett	Profile E-E': Vantage Point 18; Photo 8



Profile A-A'

Profile A-A' is a west to east profile, beginning near NYS Route 409 and ending at NYS Route 14. Views from Vantage Points 1 and 2 toward the project site are obstructed by close-in vegetative cover and topography. Log Photograph No. 14 further depicts the limited to nonexistent potential for visual impacts.

Profile B-B'

Profile B-B' follows a bearing generally from southwest to northeast on which close-in vegetative growth restrict views of the project site from Vantage Point 3. Log Photograph No. 16 depicts representative views from the southwest toward the site. Vantage Point 4 and 5 have existing views of the currently approved affected area of the mine. From these locations, the proposed westward expansion will not be discernible, as the existing excavation face will simply become more distant. Partial views of the proposed expansion to the north may present minor impacts to views from these vantage points.

Profile C-C'

Profile C-C' exhibits a northwest to southeast orientation. Any views, including Vantage Points 7, 8, 9, and 10 from the southeast toward the project site, are obscured by close-in vegetation and topography. Log Photographs No. 12 and 13 are representative of views from the northwest. As shown in the profiles, all views from Watkins Glen State Park are obstructed by close-in vegetation and topography.

Profile D-D'

Profile D-D' orients from west to east. Views from the northeast, including Vantage Points 13 and 14 toward the proposed project area, have the least obstructed views of the site. However, from these locations the proposed west-ward expansion will not be discernible, as the existing excavation face will simply become more distant. Partial views of the proposed expansion to the north may present minor impacts to views from these vantage points. See Log Photographs No.2, 3, and 7. Additionally, these views are from significant distance (from approximately 3,590 feet to over two miles). As such, the proposed activities will be barely noticeable to imperceptible. Views from vantage points 11 and 12 are screened by intervening topography and vegetation.

Profile E-E'

Profile E-E' is a southwest to northeast profile. Views from Vantage Points 15, 16, and 17 are obstructed by heavy vegetation and topography. See Log Photograph No. 8, which location generally



follows Profile E-E'. The view towards the proposed expanded affected area from Vantage Point 18 is from a distance of nearly two miles and currently includes the existing excavation area. From this vantage point, the proposed expansion will be barely noticeable to imperceptible, as the existing excavation face will simply become more distant. Partial views of the proposed expansion to the north may present minor impacts to views from these vantage points.

As indicated by the sight line profiles described above and as a result of intervening topography, significant sight distances and surrounding vegetative cover, there will be no significant impacts to visual resources as a result of mining activity.

Watkins Glen Grand Prix Road Course

The Watkins Glen Grand Prix Road Course (“Course”) is a National Register-listed auto racetrack over public rights of way. The original 6.6-mile track was used from 1948 to 1952 and was listed on the National Register of Historic Places in 2002. An initial consultation submission was made on October 24, 2017 to NYS Office of Parks for its review and determination of potential impacts to nearby historical and cultural resources. The NYS Office of Parks responded on November 20, 2017, with a request for additional information regarding potential visual and aesthetic impacts to a 0.5-mile portion of the Course that borders the IGN Property along NYS Route 409. JMT prepared a response letter, dated April 23, 2019, to satisfy their request. Subsequently, the Office of Parks issued a letter on May 23, 2019, determining that the response resolved their concerns regarding the project’s potential impact on the Road Course.

The NYS Office of Parks also issued an additional letter on July 2, 2019, indicating concerns separate from that of the Road Course. IGN addressed this letter in a response, dated September 1, 2021. On December 10, 2021, the OPRHP issued a findings letter concluding that the project will have “No Adverse Impact” on historic resources. All of these correspondences are included in Appendix K.

Additional Potential Aesthetic Resources

In accordance with NYSDEC Program Policy DEP-00-2, potential aesthetic resources were reevaluated and identified within a 5-mile radius of the proposed expansion area. These resources are collectively depicted on the attached Table 2, Inventory of Aesthetic Resources and on Figure 6, Location Map – Inventory of Aesthetic Resources. Included in this inventory list are: (12) twelve listings on the National Register of Historic Places; (1) one state park; (6) six local (municipal) parks; (1) one wildlife management area; (1) one scenic lake; (1) one national forest; (2) trails; and (1) one state forest. Much of these identified resources include those which are already described above, or, if not previously identified, are in close proximity to those which are and can adequately be represented through the



previously assessed resource. For example, resources identified on the attached inventory list as: 1, 8, 7, and 9 can collectively be represented by listed resource 9: First Baptist Church of Watkins Glen due to similar topographic conditions and their physical locations.

Similarly, identified resources 2 and 6 can collectively be represented by resource 2: Schuyler County Courthouse Complex, while resources 14 and 15 can be collectively represented by resource 14: Clute Park.

It can additionally be inferred that in some cases, similar site conditions would exhibit similar views. This appears to be the case with some of the views surrounding Seneca Lake. As explained in greater detail above, Profile E-E' intersects the lake and includes a vantage point along the lake (VP 17) obstructed by heavy vegetation and topography. Views from resources 21 and 23 would encounter similar obstructions.

Furthermore, all views from Watkins Glen State Park are obstructed by close-in vegetation and topography. Similarly, it is anticipated that views from the additional identified resources 20, 21, 22, 24, and 25 would encounter similar obstructions due to the nature of the resource and its proximity to the site. The remaining additional resources: 10, 11, 12, 18, and 19 (located southeast of the proposed expansion area) would also have obstructed views resulting from intervening topography, vegetation, and site distance.

As discussed above, and as further shown on Sheets 8 and 9 and in Appendix I, views of the existing property and the proposed expansion from NYS Route 409 are extremely limited. Existing grades, screening berms and vegetation limit views into the proposed expansion area. The site is currently permitted and operating as a sand and gravel mine. Potential visual and aesthetic impacts to the Course from continued operation of the mine site will be consistent with current conditions. There are no potential impacts to Watkins Glen Grand Prix Road Course resulting from the proposed expansion.

4.5.4 Proposed Mitigation Measures

As discussed above and shown on Sheets 8 and 9 and in Appendix I, potential impacts to visual resources are anticipated to be minimal. Any potential impacts will be further mitigated by employing concurrent reclamation practices and by limiting stripping activities as discussed in Appendix F, which will minimize the amount of disturbed area visible at any one time. No additional mitigation is required.

4.6 NOISE

The final scoping outline for the proposed action does not require additional assessment of potential noise impacts. Prior NYSDEC documentation has indicated that previous noise impact assessments



adequately demonstrated that potential impacts to noise would be insignificant or mitigatable. However, given that this application includes revisions to site configuration that have the potential to alter noise propagation from site activities, IGN elected to have an updated noise impact assessment completed in support of this EIS. The Noise Projection Analysis is included as Appendix D.

4.6.1 Existing Environmental Setting

The site is located on a portion of an approximately 281-acre property. The site itself consists of an active sand and gravel mine, and agricultural lands. Primary sound sources from the existing mine site include equipment for the excavation, hauling, and processing of sand and gravel materials. Surrounding land uses include rural, agricultural, residential, wooded and parkland. The site is bounded to the northwest by a state highway (NYS Route 409).

Ambient noise levels within and adjacent to the site were observed at three locations on September 11, 2017 (see Appendix D). Observations were completed while the mine site was not operating. Observed sound levels ranged from 52.3 dB(A) to 57.9 dB(A).

In order to determine a baseline existing condition, ambient sound conditions and currently approved activities were modeled in SoundPlan®, an industry-standard noise assessment software package. The modeled existing condition utilized equipment-specific sound propagation values for industry-typical equipment, including an excavator, loader, processing plant, and haul trucks. All input data is included in Appendix D.

Figures depicting the modeled existing condition are located in Appendix D. As indicated on those figures, three potential residential receptors, and a receptor located at Watkins Glen State Park- Indian Trail Overlook, were identified for the purposes of the noise evaluation. These receptors were selected based upon several criteria, including distance from the expanded mine site boundary, intervening terrain, and sensitivity. The residential receptors chosen were the three most proximal residences to the north, east and west. The fourth receptor, The Indian Trail Overlook in Watkins Glen State Park was included at the request of NYSDEC. Modeled existing conditions at the four receptors range from 52.3 dB(A) at Receptor 4 to the south, to 61.6 dB(A) at receptor 2 to the north of the project.

4.6.2 Potential Impacts

Under the proposed action, observable sound levels have the potential to increase as mobile mining equipment operations move closer to potential receptors. Processing equipment will remain where it is currently located. As the mine expands, mobile equipment will work from the current mining face to the west and north, maintaining a working face between operations and potential receptors wherever



possible. This practice maintains the maximum intervening topography between sound sources and receptors, which maximizes noise attenuation from topographic barriers.

In order to assess the potential impacts associated with the proposed action, a projected future condition was modeled in SoundPlan® depicting mobile equipment operating at the extreme margins of the proposed excavation area, proximal to potential receptors. Operations were modeled at final-grade configurations to reflect the progression of the active mining face throughout the life of excavation. Mobile equipment was modeled operating at multiple locations simultaneously to reflect a worst-case scenario. An additional scenario was generated simulating operations as the mine approaches the southeast corner of the LOM, 500 ft from Receptor 4, which is located a trail/ bridge within Watkins Glen State Park. See Appendix D for more details on the each scenario.

Appendix D illustrates the projected sound levels resulting from the proposed modification. Sound levels to the east and south are virtually unchanged.

Planned screening berms to the southwest and north, and the existing screening berm to the northwest, in combination with intervening topography, significantly limit sound propagation from the mine site. Projected sound levels at the residential receptors range from 56.9 dB(A) to 63.1 dB(A), reflecting potential sound level increases in of 4.5 dB(A) at Receptor 1 and 3.2 dB(A) at Receptor 3. Receptor 4 has a maximum potential sound increase of 0.5 dB(A) in the southeast corner mining scenario. Results of the analysis indicate that observable sound levels at Receptor 2 may be reduced by as much as 3.6 dB(A), in part due to additional topographic barrier resulting from the revised mining and reclamation plan.

4.6.3 Proposed Mitigation Measures

NYSDEC's program policy Assessing and Mitigation Noise Impacts states that increases in sound pressure of 0-5 dB(A) are unnoticeable to tolerable to human hearing. Sound levels at two proximal residential receivers are anticipated to increase no more than 4.5 dB(A) and no more than 0.5 dB(A) at Receptor 4, an unnoticeable to tolerable change in sound level. No additional mitigation is required. IGN will continue to utilize the following best management practices to minimize potential noise impacts to surrounding receptors:

1. All equipment is to be muffled to meet MSHA standards;
2. Portable processing facilities will be strategically placed to take full advantage of existing topographic barriers and to-be-constructed mine faces; and



3. Natural barriers created by the active mine faces and additional screening berms as described in Section 4.6 will act to reduce noise levels when equipment is operating.

All plant employees and equipment operators will be instructed in the operation of equipment to reduce noise. Below is a list of techniques that will be employed at the site to reduce noise:

1. Employees will be instructed in the proper operation and maintenance of all equipment;
2. Employees will be instructed not to "race" the engines of any equipment;
3. Employees will be instructed to report any operating irregularities in equipment that may increase the level of noise generated by that equipment;
4. Vehicle speeds will be controlled to reduce engine noise during transport of material; and
5. All plant equipment will be properly maintained and secured.

4.7 CULTURAL RESOURCES

4.7.1 Existing Environmental Conditions

There are no identified cultural or historical resources at the mine site. However, Watkins Glen State Park is eligible for listing on both the National and State Registries of Historic Places. The characteristics of Watkins Glen State Park make it eligible for listing under the National and State Historic Registries because it meets the following criteria:

- Associated with events that have made a significant contribution to the broad patterns of our history (in the area of conservation and recreation) and;
- Embodies the distinctive characteristics of a type, period, or method of construction; or represents the work of a master; or possess high artistic values; or represents a significant and distinguishable entity whose components may lack individual distinction (in the area of landscape design and recreational architecture)

According to NYS Office of Parks, the historical significance of Watkins Glen State Park extends over 100 years, since it opened as a private park/resort in the 1860s. The park became public in 1906, when 103 acres were purchased by New York State. Since that time, the park has been overseen by several commissions and has undergone multiple development initiatives -- even surviving a massive flood in 1935, which damaged not only the infrastructure of the park, but also impacted the park's ecology to the extent that it changed the course of streams. The 1869-74 suspension bridge is the oldest remaining



structure in the park. Other infrastructure remaining throughout the park vary in age, dating back to circa 1911. Currently, improvements are being made to the main entrance of the expanded 776-acre park, which is open year-round and includes such seasonal activities as swimming and camping.

Watkins Glen Grand Prix Road Course

The Watkins Glen Grand Prix Road Course is a National Register-listed auto racetrack over public rights of way. The original 6.6-mile track was used from 1948 to 1952, and was listed on the National Register of Historic Places in 2002. An initial consultation submission was made on October 24, 2017, to NYS Office of Parks for its review and determination of potential impacts to the nearby historical and cultural resources. Office of Parks responded on November 20, 2017, with a request for additional information regarding potential visual and aesthetic impacts to a 0.5-mile portion of the Course that borders the IGN Property along NYS Route 409. A response was provided to NYS Office of Parks on April 23, 2019, and a “no adverse impact” determination was issued on December 10, 2010. Relevant correspondence is included in Appendix K.

4.7.2 Potential Impacts

It is not anticipated that the expansion will adversely impact the eligibility of the park or have the potential to impact the Park’s cultural characteristics which qualify it for eligibility. Potential impacts to visual resources associated with the park are addressed in Section 4.5. Potential impacts to hydrogeology and ecology of the park are discussed in Sections 4.3 and 4.4. There are no potential impacts to the park associated with the proposed expansion.

Sections 4.5 and 4.7 discuss potential impacts to the Watkins Glen Grand Prix Road Course. No potential visual or aesthetic impacts to the Watkins Glen Grand Prix Road Course are anticipated.

4.7.3 Mitigation Measures

The proposed expansion mitigates potential impacts by design. No additional mitigation is required.

5.0 ALTERNATIVES TO THE PROPOSED ACTION

5.1 NO ACTION ALTERNATIVE

The "No Action" alternative means that the mine would not be expanded. However, demand for construction aggregates will remain unchanged. Such demand will create new activity at other sites and continued activity at existing sites. Expanding the existing mine site limits potential impacts by keeping them localized to an existing operational site. Therefore, the no action alternative is not a reduction of



impacts, but instead a shifting of impacts to other sites. The disadvantages associated with the no-action alternative are significant and include:

1. Failure to provide economic growth and development at the local and regional levels;
2. Failure to provide needed aggregate resources to regional markets consistent with the Mined Land Reclamation Law;
3. Failure to provide vitally needed state approved aggregate materials to regional markets; and
5. Failure to process locally available mineral resources that are needed by the construction industry in Schuyler County and other counties in the area.

A consequence of the "no action" alternative will be even greater levels of exploration activity for future reserves. However, extensive experience has proven that finding economically viable resources is very difficult. Therefore, a possible consequence, if no alternative site is found, is a marked increase in local construction costs.

5.2 ALTERNATIVE SITES

The project site is the only site in the immediate market area that possesses both the quality and quantity of material necessary to be able to supply, for the long term, approved materials meeting NYSDOT specifications. IGN does not own or control additional properties that have the available construction aggregates reserves needed to meet DOT specifications and meet the needs of the community and market area. Furthermore, the project site is already in use for mining. Expansion of the existing facility is likely to have fewer environmental impacts than development of an alternative, previously undisturbed site.

5.3 ALTERNATIVE SIZE

The scale of the project could be altered by varying the amount of material to be removed. This could be accomplished by either increasing or decreasing the lateral project extent (LOM Boundary) or excavation depth. Either scenario would alter the available mineable resources, which would have economic impacts, as the availability of aggregate materials for local and regional markets would be impacted.

Alternative unconsolidated mining project sizes may have marginally variable potential for impacts to surface water, ecological, noise, visual and aesthetic, or cultural resources. However, the scale of potential impact is not proportional to project size. Saleable materials would be produced at the same



rate by the same processing and mobile equipment. Material would be removed from the site by the same trucks at the same rate as the proposed project. The project site is the location of an existing sand and gravel mine, and these impacts already exist.

An increase in proposed depth of mining that results in mining below the groundwater table may have the potential to marginally impact groundwater resources by way of small perturbations to the groundwater table and groundwater flow regime. Such impacts would likely be minimal and may result in part from evaporation from surface water excavation ponds. As noted, the revised proposal represents a reduction in the depth of mining as compared to the original application, and represents an alternative designed to eliminate the potential for impacts to groundwater resources. Further reducing the proposed depth of excavation does not have the potential to increase, decrease, or otherwise alter the lack of potential impact to groundwater resources under the proposed configuration.

The revised proposal also reflects a reduced size from the original application. The current proposal removes a formerly proposed material-transfer tunnel underneath NYS Route 409, and an associated rail siding for loading of rail cars for transport to market. The current proposal further reduces size from the original application by increasing setbacks. The removal of the tunnel and rail siding and the increase in setbacks reduce and mitigate potential impacts to noise, visual and aesthetic, and cultural resources by eliminating additional disturbances and maximizing screening buffers.

Based on initial and continuing investment toward the project, further downsizing of the operation would affect the economic viability of the project, without providing any significant environmental benefit. There are substantial costs associated with the start of the operation. These costs include: site development, equipment, permitting and environmental review. The outlay of capital dollars is substantial and continues throughout the life of the project, while a return on investment occurs only after permit issuance, commencement of operations and product sales.

5.4 ALTERNATIVE DESIGN AND/OR TECHNOLOGIES

5.4.1 Site Design

The site is an existing sand and gravel mine. The proposed layout maximizes the potential resource while minimizing potential environmental impacts. Alternate layouts would alter the size and scale of the project, or would require relocating the existing processing plant or site infrastructure. Existing and proposed site infrastructure is oriented to provide the maximum environmental protection practicable. Additionally, the current location of the processing plant maximizes the visual and noise screening capacity of adjacent mine faces and surrounding topography.



The minimum property line setback proposed is at least 25 feet in accordance with DEC standards. The project has been designed to include enhanced setbacks between the final limits of the mine and adjacent properties. If setbacks are further increased along property lines, mineable resources could be significantly decreased resulting in similar consequences as those resulting from alternate scale development.

5.4.2 Operational Practices

The existing mine and proposed expansion will continue to utilize industry-standard equipment. There are no true alternatives to standard mechanical excavation and processing equipment capable of safely, effectively, and efficiently producing saleable construction aggregate from mined sand and gravel deposits.

5.5 ALTERNATIVE LAND USE

Alternative reclamation land uses could include a lake or public parkland. Although the lake objective would be visually appealing, it would not be practical at this site, as mining will occur entirely above the water table. Furthermore, the anticipated concurrent reclamation activities would not be possible, resulting in an increase of dust, erosion, and visual impacts due to an increase in exposed (unvegetated) land.

The public park objective would enhance the nearby state parklands, but would require an extensive amount of funds to plan, authorize, and execute such an action, thus making it infeasible for IGN.

The current reclamation objective for the mine site is vegetated open space. Vegetated open space is consistent with a variety of land uses, including the surrounding rural, agricultural, forested, residential and parkland uses. Much of the site is currently used for agricultural purposes (livestock pasture). Continued agricultural use across the area proposed for expansion would preclude the use of the geologic reserves in these areas. However, the landowner owns similar and adjacent lands that can be utilized for these purposes. Furthermore, as mining and concurrent reclamation activities progress, agricultural activities may move across different portions of the site. Furthermore, though site soils are not agriculturally important soils, soil and overburden materials will be stripped in advance of mining and stockpiled for use in reclamation. In these respects, agriculture is not viewed as an alternative land use, but rather, a concurrent and potential future land use.

5.6 ALTERNATIVE DEVELOPMENT SCHEDULE

Alternative development schedules could include the acceleration or slow-down of the rate of excavation. However, this application has no bearing on the rate of excavation. Rate of excavation is a



function of market demand and, except for extreme cases, not a viable method for eliminating or mitigating potential environmental impacts. Increasing or decreasing the rate of extraction may have the potential to alter the duration of the mining operation, and therefore the duration of environmental impact, but would not result in an overall change to the magnitude of potential environmental impact.

6.0 LIST OF APPLICATION DOCUMENTS

The following documents were used in preparation of this DEIS:

- NYSDEC Draft Environmental Impact Statement (DEIS) Final Scoping Outline for It's Greener Now (IGN), Inc. - Padua Pit, dated August 18, 2008 (Appendix H)
- NYSDEC SEQR Positive Declaration Determination of Significance, Project Number 8-4424-00006/00001, dated June 3, 2008
- NYSDEC SEQR Amended Negative Declaration, Project Number 8-4424-00006/00001, dated December 21, 2007
- USFWS IPaC Resource Results (Appendix A)
- New York Natural Heritage Program Documentation (Appendix C)
- It's Greener Now, Inc. - Padua Ridge Gravel Mine, Noise Projection Analysis, prepared by JMT, dated August 2021 (Appendix D)
- It's Greener Now Inc. - Padua Ridge Gravel Mine, Mined Land Use Plan, prepared by JMT, dated July 2022 (Appendix F)
- It's Greener Now, Inc.- Padua Ridge Gravel Mine, Stormwater Pollution Prevention Plan, prepared by JMT, dated June 2022 (Appendix G)
- It's Greener Now, Inc. - Padua Gravel Gravel Mine, Visual Assessment Photographic Log, prepared by JMT, dated September 2021 (Appendix I)
- It's Greener Now, Inc. - Padua Ridge Gravel Mine, WGSP Hydrogeologic and Ecologic Documentation, prepared by JMT, dated April 2019 (Appendix J)
- NYS Office of Parks, Recreation, and Historic Preservation Documentation (Appendix K)
- It's Greener Now, Inc. - Padua Ridge Gravel Mine, Environmental Assessment Form, prepared by JMT, dated September 2021 (Appendix L)
- Geological Report of Proposed Operations (Original), prepared by Lansing Hisert Group, dated March 2004
- Stormwater Management Report, prepared by H2H Associates, LLC, dated March 15, 2006
- Stormwater Analysis for the Padua Ridge Gravel Mine, prepared by Fagan Engineers, dated February 2011
- Mine Permit Drawings for Padua Ridge Gravel Mine, prepared by Fagan Engineers, Last revision date, June 1, 2011



DRAFT ENVIRONMENTAL IMPACT STATEMENT
It's Greener Now, Inc. – Padua Ridge Gravel Mine Town of Dix, New York

- Response to NYSDEC Comments, dated August 10, 2007, prepared by H2H Associates, LLC, dated October 3, 2007
- Mined Land Reclamation Permit Modification, prepared by H2H Associates, dated December 8, 2006, Revised March 27, 2007
- Noise Assessment Report, prepared by H2H Associates, LLC, dated April 2005, revised February 28, 2007
- Noise Assessment Report, prepared by H2H Associates, LLC, dated February 2004



TABLES

TABLE 1 - GROUNDWATER WELL DATA SUMMARY

Well ID	Average GW Height (GW Gradient Maps in dEIS)	Ground Water Elevation Seasonal High (ft)	Groundwater Elevation (ft) Seasonal Low	Ground Elevation (ft)
MW-1-17	888.6	889.8	886.421	972.3
MW-2-17	814.3	810.0	808.335	896.0
MW-3-17	838.7	838.6	837.955	839.2
MW-4-17	849.7	849.1	841.1	863.0
MW-5-17	867.2	866.8	864.04	873.7
EW-1S	947.8	948.6	947.995	971.5
EW-1D	946.8	946.7	946.019	971.8
EW-2D	913.5	915.0	914.223	985.1
B-1S	911.8	912.5	911.384	940.4
B-2D	858.5	857.9	856.194	871.9



TABLE 2

AESTHETIC RESOURCES WITHIN 5 MILES OF PADUA RIDGE GRAVEL MINE

National Register of Historic Places

1. Chapman, A. F., House
2. Schuyler County Courthouse Complex
3. U.S. Post Office - Watkins Glen
4. Watkins Glen Commercial Historic District
5. Watkins Glen Grand Prix Course, 1948-1952
6. Watkins Glen High School
7. St. James Episcopal Church
8. First Presbyterian Church of Watkins Glen
9. First Baptist Church of Watkins Glen
10. Montour Falls Historic District
11. Brick Tavern Stand
12. Montour Falls Union Grammar School

State Parks

13. Watkins Glen State Park

Municipal Parks

14. Clute Park
15. Lakeside Park
16. LaFayette Park
17. Seneca Harbor Park
18. Shequaga Falls
19. Havana Glen Park

National Wildlife Refuge/ State Game Refuge

20. Catharine Creek Wildlife Management Area

A site area, lake, reservoir, or highway resource designated or eligible for designation as scenic, including NYS scenic byways

21. Seneca Lake

National Park System, Recreation Areas, Seashores, Forest

22. Fingers Lakes National Forest



State or Federally-designated trail or one proposed for designation

- 23. North Country Trail (Watkins Glen State Park)
- 24. Catherine Creek Trail

State Nature and Historic Preserve Areas

- 25. Sugar Hill State Forest

Note: Identification number (e.g, 23.) corresponds with each resource depicted on *Figure 1, Location Map – Inventory of Aesthetic Resources*.



FIGURES

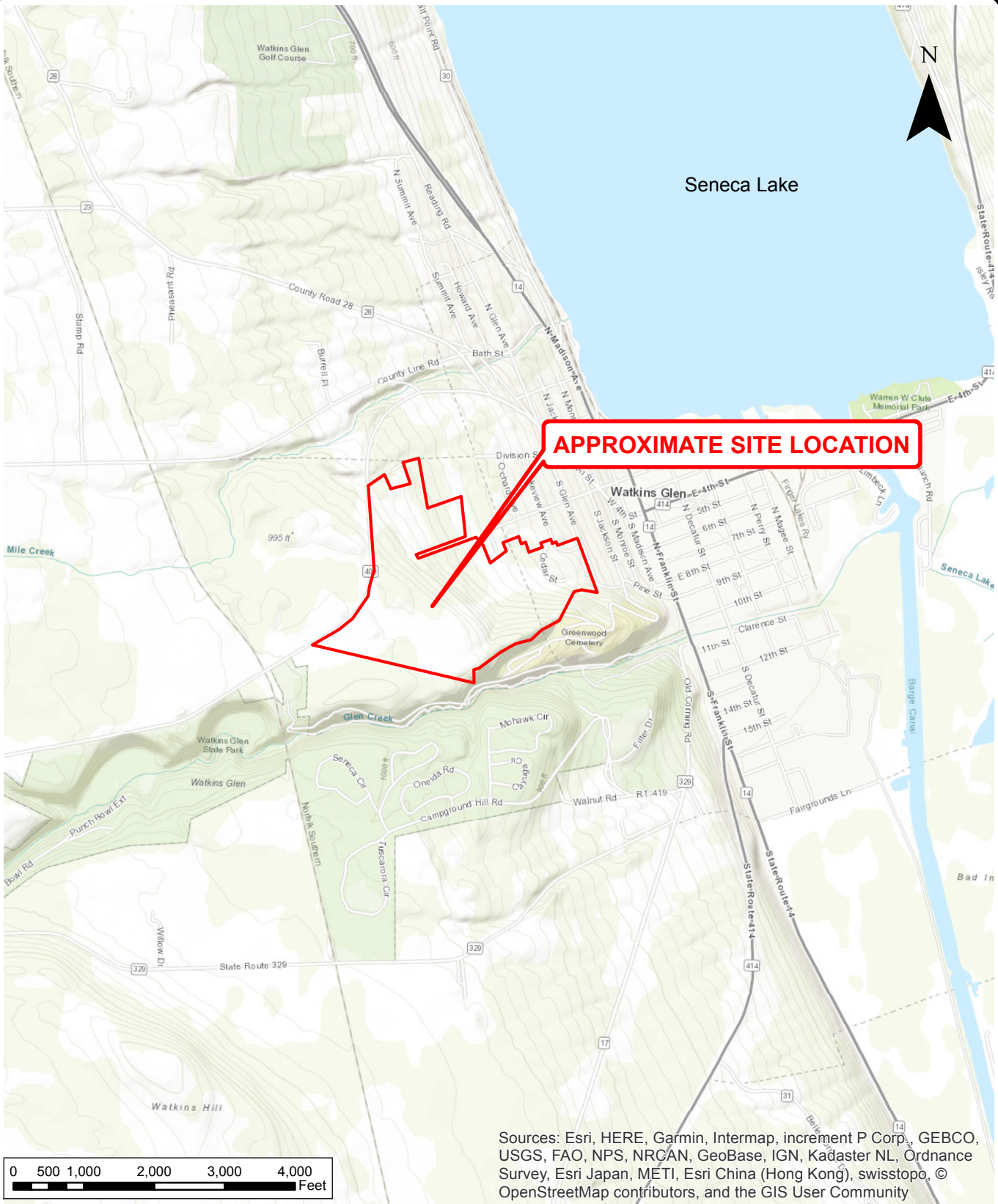

Sources: Esri, HERE, Garmin, Intermap, increment P Corp., GEBCO, USGS, FAO, NPS, NRCAN, GeoBase, IGN, Kadaster NL, Ordnance Survey, Esri Japan, METI, Esri China (Hong Kong), swisstopo, © OpenStreetMap contributors, and the GIS User Community





19 British American Blvd., Latham, New York 12110
 P: (518) 782-0882 F: (518) 782-0973 www.jmt.com

SITE LOCATION MAP
IT'S GREENER NOW, INC.
 PADUA RIDGE GRAVEL MINE

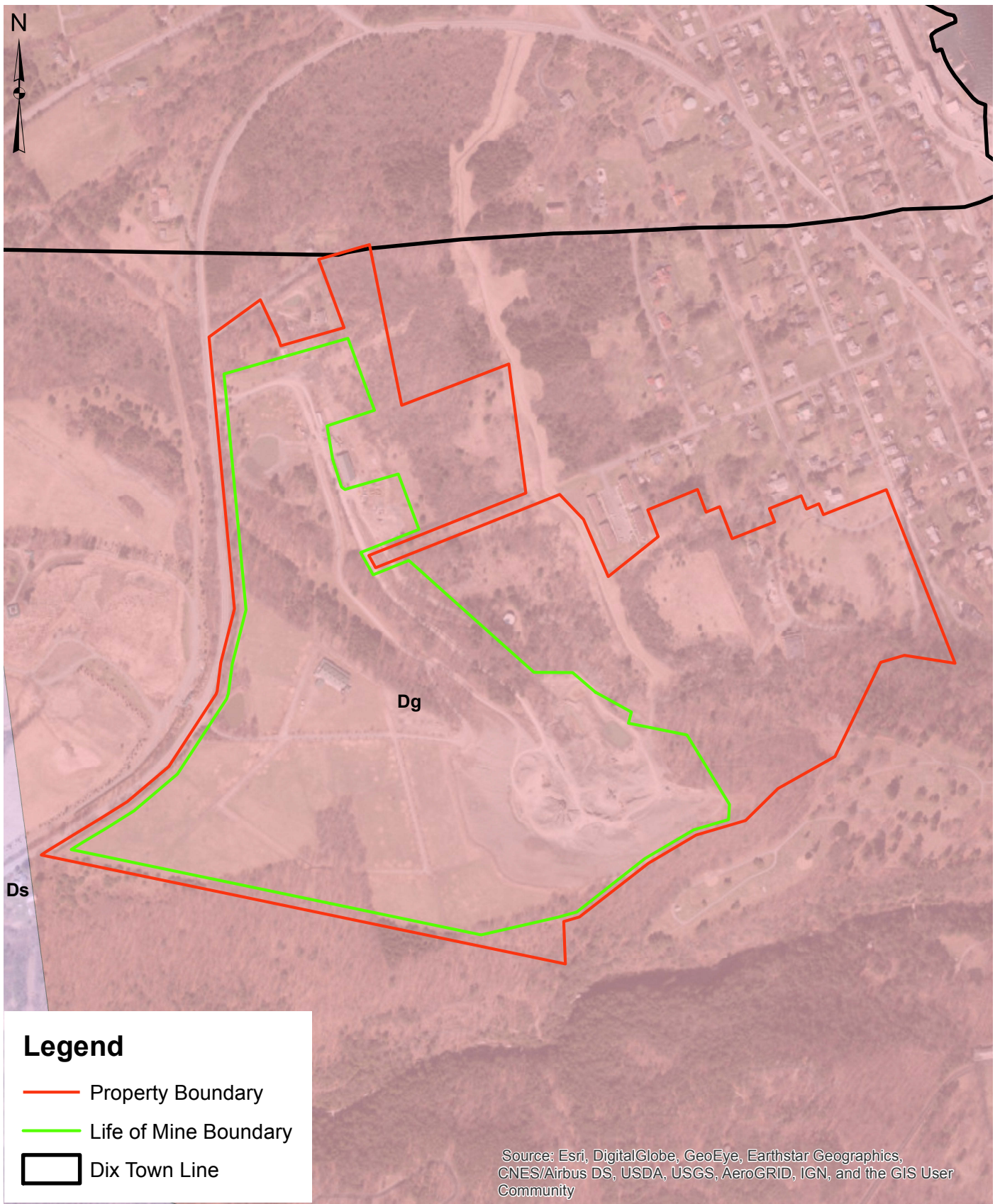
TOWN OF DIX SCHUYLER CO., NY



Legend

-  Property Boundary
-  Life of Mine Boundary
-  Dix Town Line

Source: Esri, DigitalGlobe, GeoEye, Earthstar Geographics, CNES/Airbus DS, USDA, USGS, AeroGRID, IGN, and the GIS User Community





19 British American Blvd., Latham, New York 12110
P: (518) 782-0882 F: (518) 782-0973 www.jmt.com

BEDROCK GEOLOGY MAP
IT'S GREENER NOW, INC.
PADUA RIDGE GRAVEL MINE

TOWN OF DIX

SCHUYLER CO., NY

Bedrock Geology

-  Dg - West River Shale; Genundewa Limestone; Penn Yan and Geneseo Shales; all except Henesee replaced eastwardly by Ithaca Formation - Shale, siltstone and Sherburne Siltstone
-  Ds - In west: Cashaqua and Middlesex Shales. In east: Rye Point Shale; Rock Stream ("Enfield") Siltstone; Pulteney, Sawmill Creek, Johns Creek, and Montour Shales.

Data Source: Geologic Map of New York, Finger Lakes Sheet, 1970

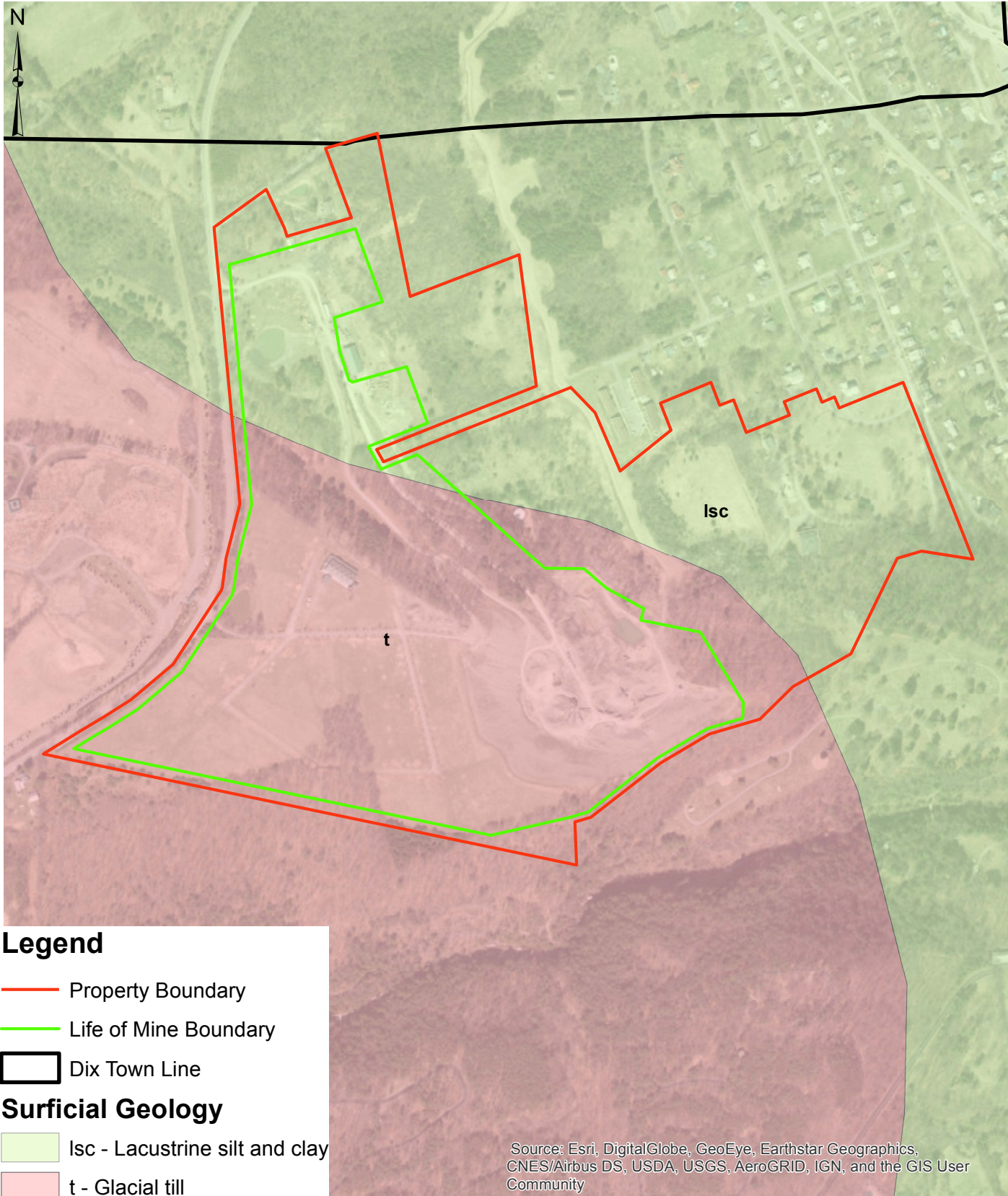

Legend

- Property Boundary
- Life of Mine Boundary
- Dix Town Line

Surficial Geology

- Isc - Lacustrine silt and clay
- t - Glacial till

Source: Esri, DigitalGlobe, GeoEye, Earthstar Geographics, CNES/Airbus DS, USDA, USGS, AeroGRID, IGN, and the GIS User Community

Data Source: Surficial Geologic Map of New York, Finger Lakes Sheet, 1986



19 British American Blvd., Latham, New York 12110
 P: (518) 782-0882 F: (518) 782-0973 www.jmt.com

SURFICIAL GEOLOGY MAP
IT'S GREENER NOW, INC.

PADUA RIDGE GRAVEL MINE

TOWN OF DIX

SCHUYLER CO., NY

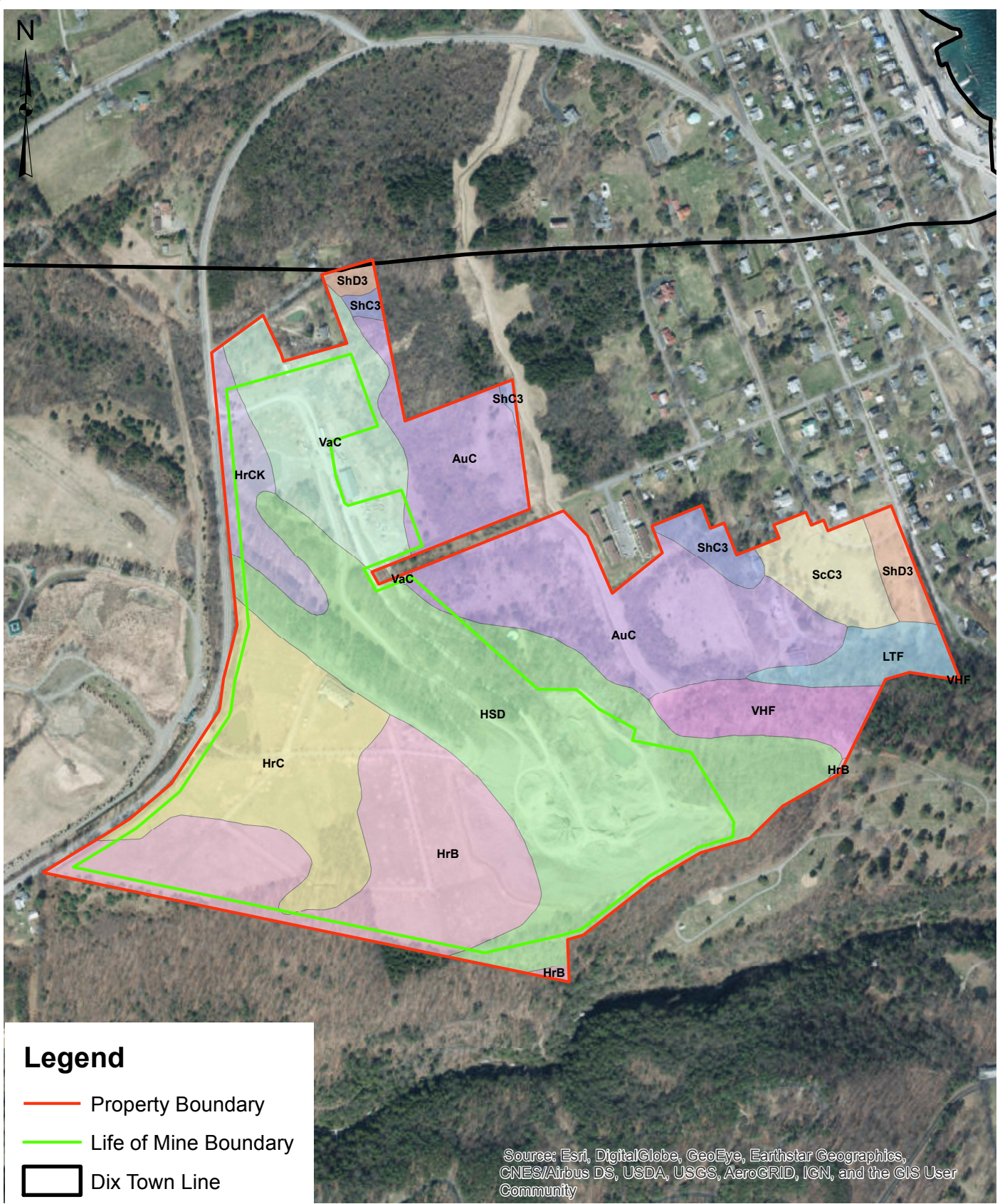

Legend

- Property Boundary
- Life of Mine Boundary
- Dix Town Line

Source: Esri, DigitalGlobe, GeoEye, Earthstar Geographics, CNES/Airbus DS, USDA, USGS, AeroGRID, IGN, and the GIS User Community













19 British American Blvd., Latham, New York 12110
 P: (518) 782-0882 F: (518) 782-0973 www.jmt.com

SOIL MAP
IT'S GREENER NOW, INC.
 PADUA RIDGE GRAVEL MINE

TOWN OF DIX

SCHUYLER CO., NY

Soil Type

-  AuC - Aurora channery silt loam, 8 to 15 percent slopes
-  HSD - Howard soils, moderately steep
-  HrB - Howard gravelly loam, 3 to 8 percent slopes
-  HrC - Howard gravelly loam, 8 to 15 percent slopes
-  HrCK - Howard gravelly loam, rolling
-  LTF - Lordstown-Arnot complex, very steep
-  ScC3 - Schoharie silty clay loam, 8 to 15 percent slopes, severely eroded
-  ShC3 - Schoharie variant silty clay loam, 8 to 15 percent slopes, severely eroded
-  ShD3 - Schoharie variant silty clay loam, 15 to 25 percent slopes, severely eroded
-  VHF - Valois and Howard soils, very steep
-  VaC - Valois gravelly silt loam, 8 to 15 percent slopes

Data Source: Natural Resources Conservation Service, USDA. Web Soil Survey, 2018.

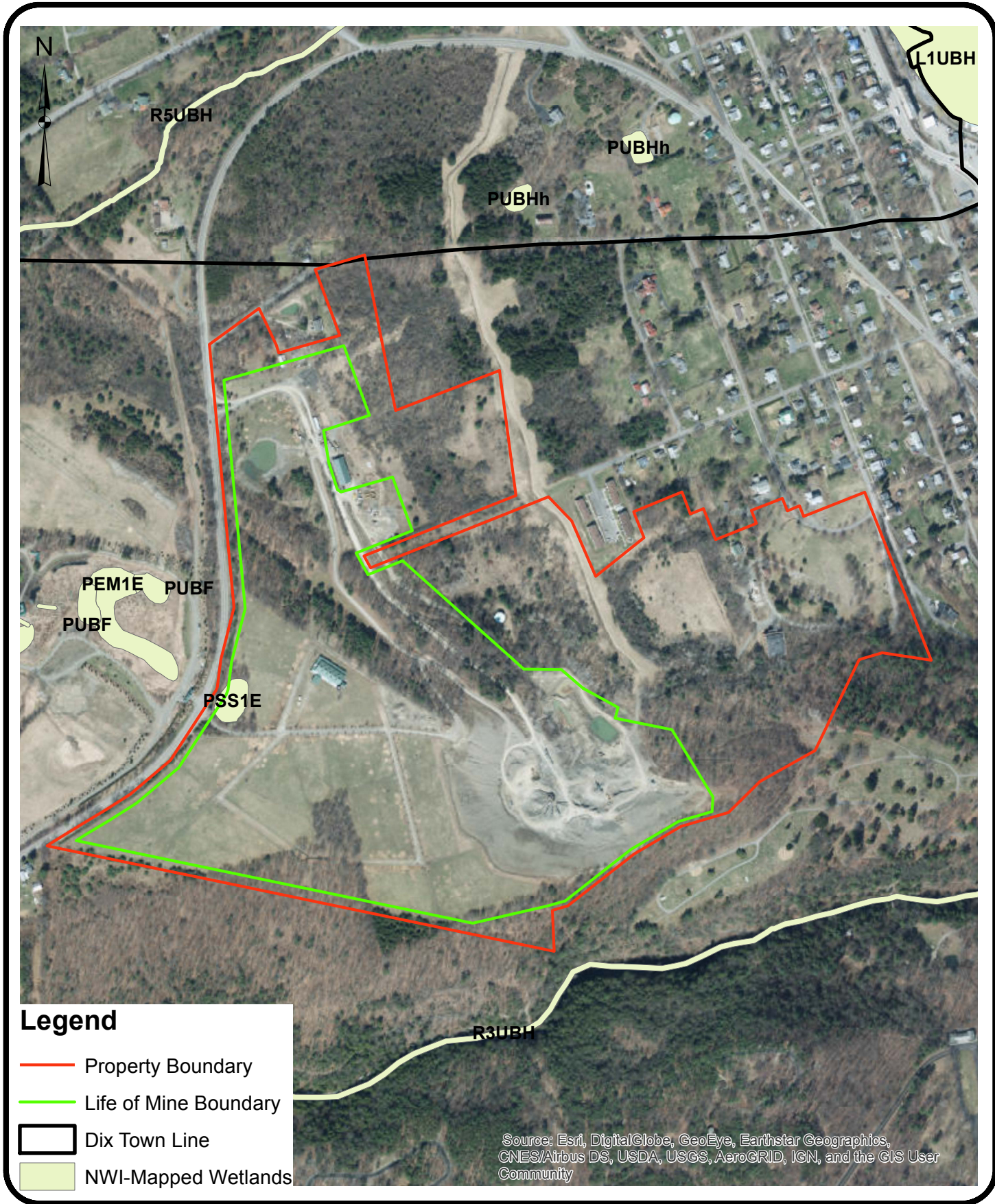

Legend

- Property Boundary
- Life of Mine Boundary
- Dix Town Line
- NWI-Mapped Wetlands

Source: Esri, DigitalGlobe, GeoEye, Earthstar Geographics, CNES/Airbus DS, USDA, USGS, AeroGRID, IGN, and the GIS User Community



19 British American Blvd., Latham, New York 12110
 P: (518) 782-0882 F: (518) 782-0973 www.jmt.com

WETLAND MAP
IT'S GREENER NOW, INC.
 PADUA RIDGE GRAVEL MINE
 TOWN OF DIX SCHUYLER CO., NY

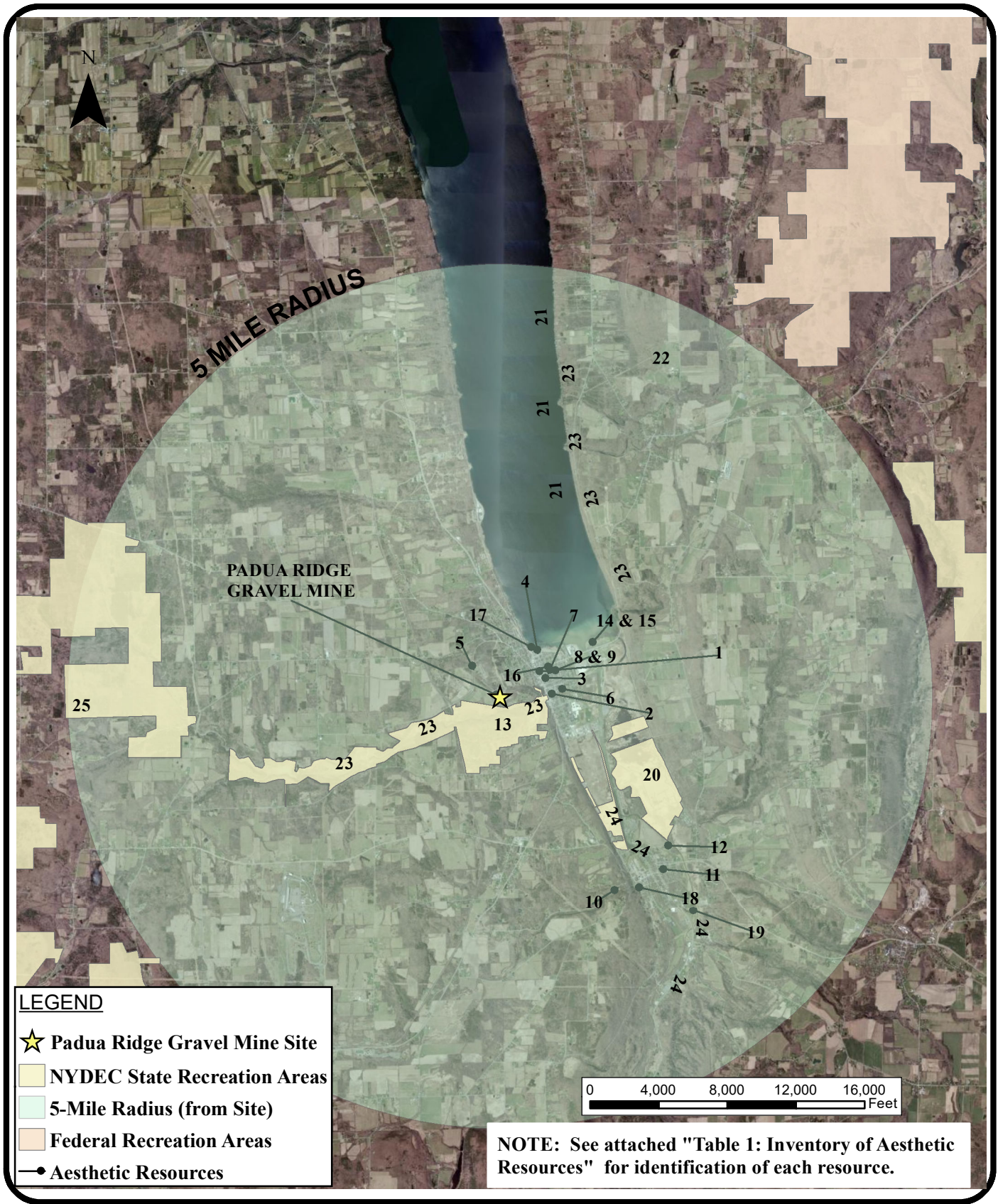

19 British American Blvd., Latham, New York 12110
 P: (518) 782-0882 F: (518) 782-0973 www.jmt.com

Location Map
 Inventory of Aesthetic Resources
IT'S GREENER NOW
 Padua Ridge Gravel Mine

Town of Dix

Schuyler Co., NY



SHEETS

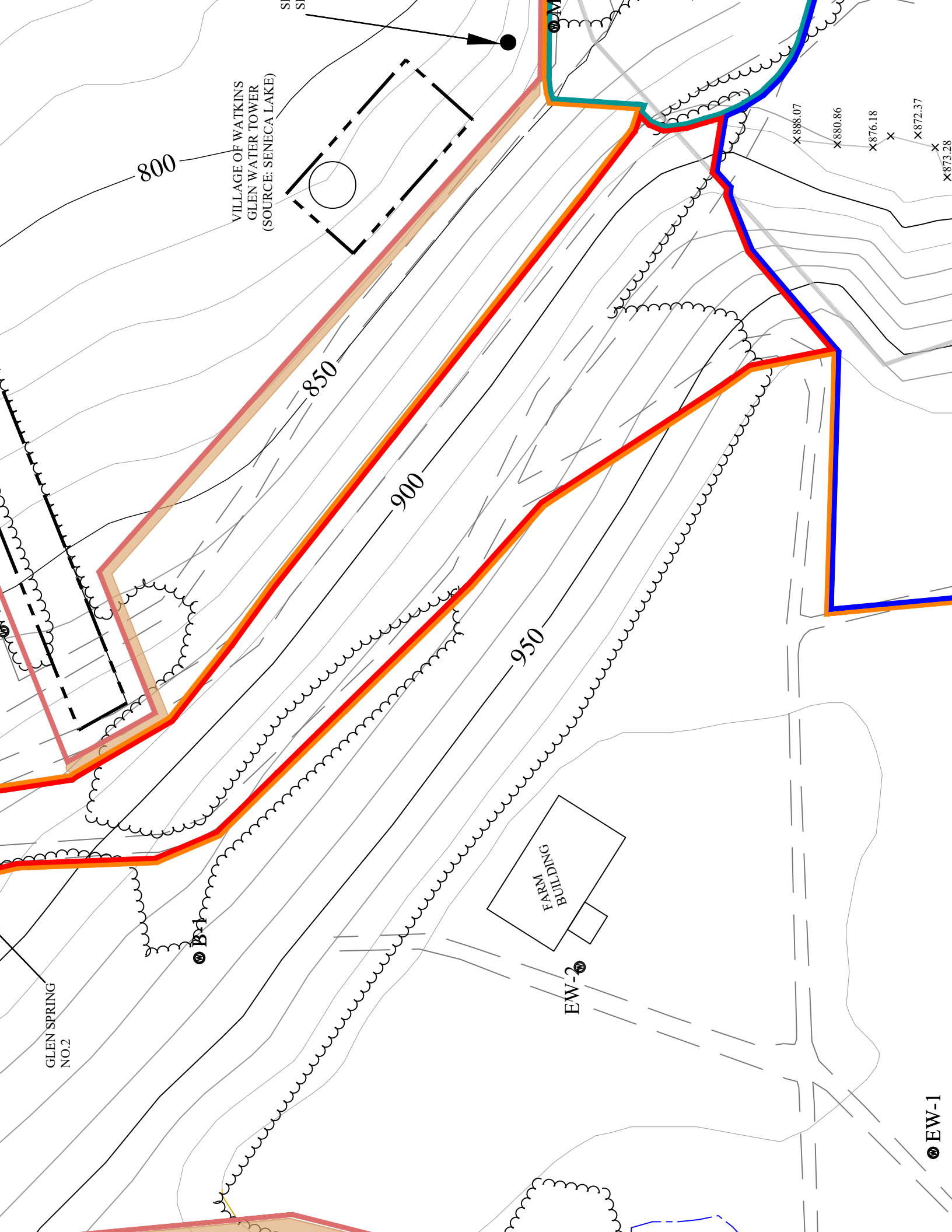

800

VILLAGE OF WATKINS
GLEN WATER TOWER
(SOURCE: SENECA LAKE)

850

900

950

X 888.07

X 880.86

X 876.18

X 872.37

X 873.28

FARM
BUILDING

GLEN SPRING
NO.2

⊙ B-1

EW-2

⊙ EW-1

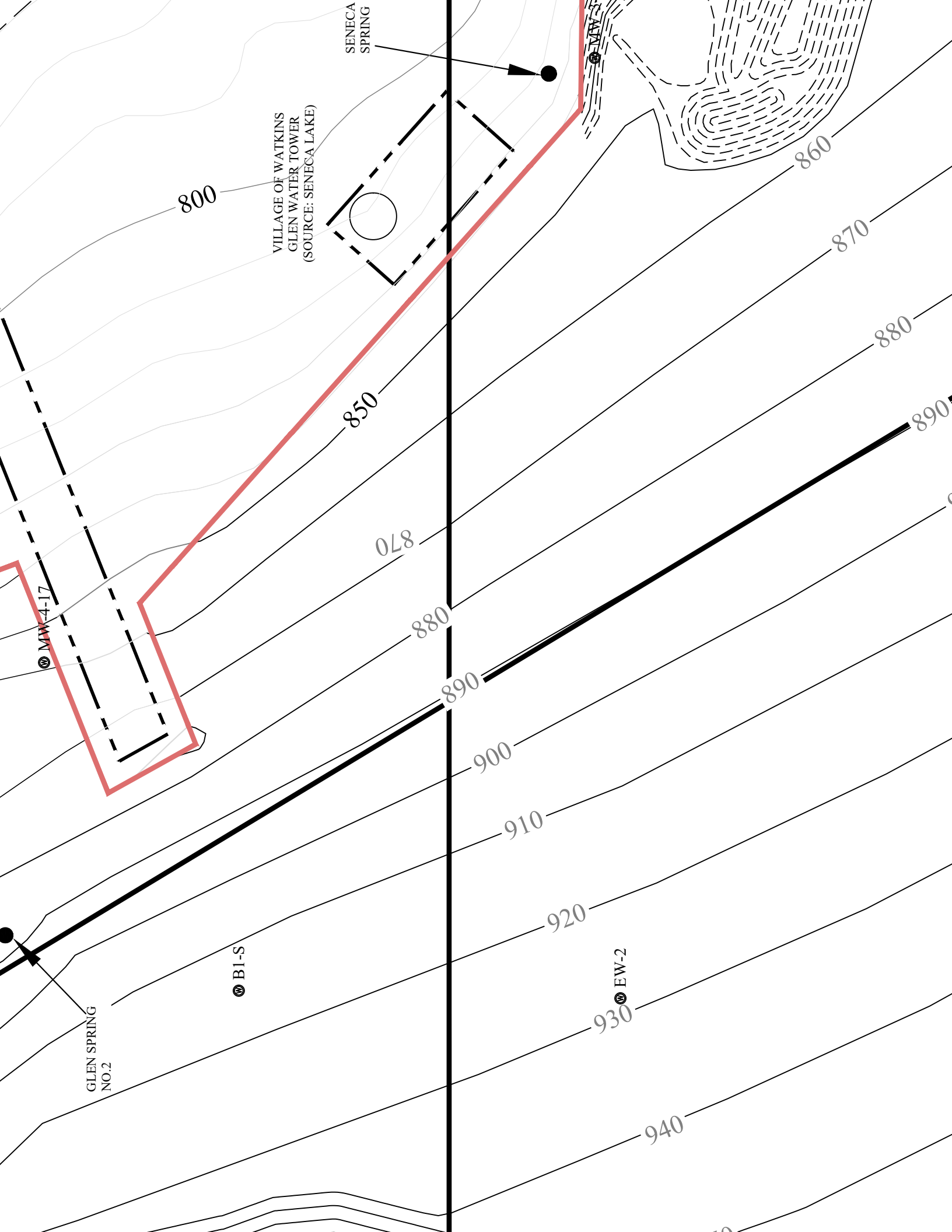

SENECA SPRING

VILLAGE OF WATKINS
GLEN WATER TOWER
(SOURCE: SENECA LAKE)

800

850

870

880

890

900

910

920

930

940

860

870

880

890

MW-4-17

B1-S

EW-2

GLEN SPRING
NO.2

MW-5

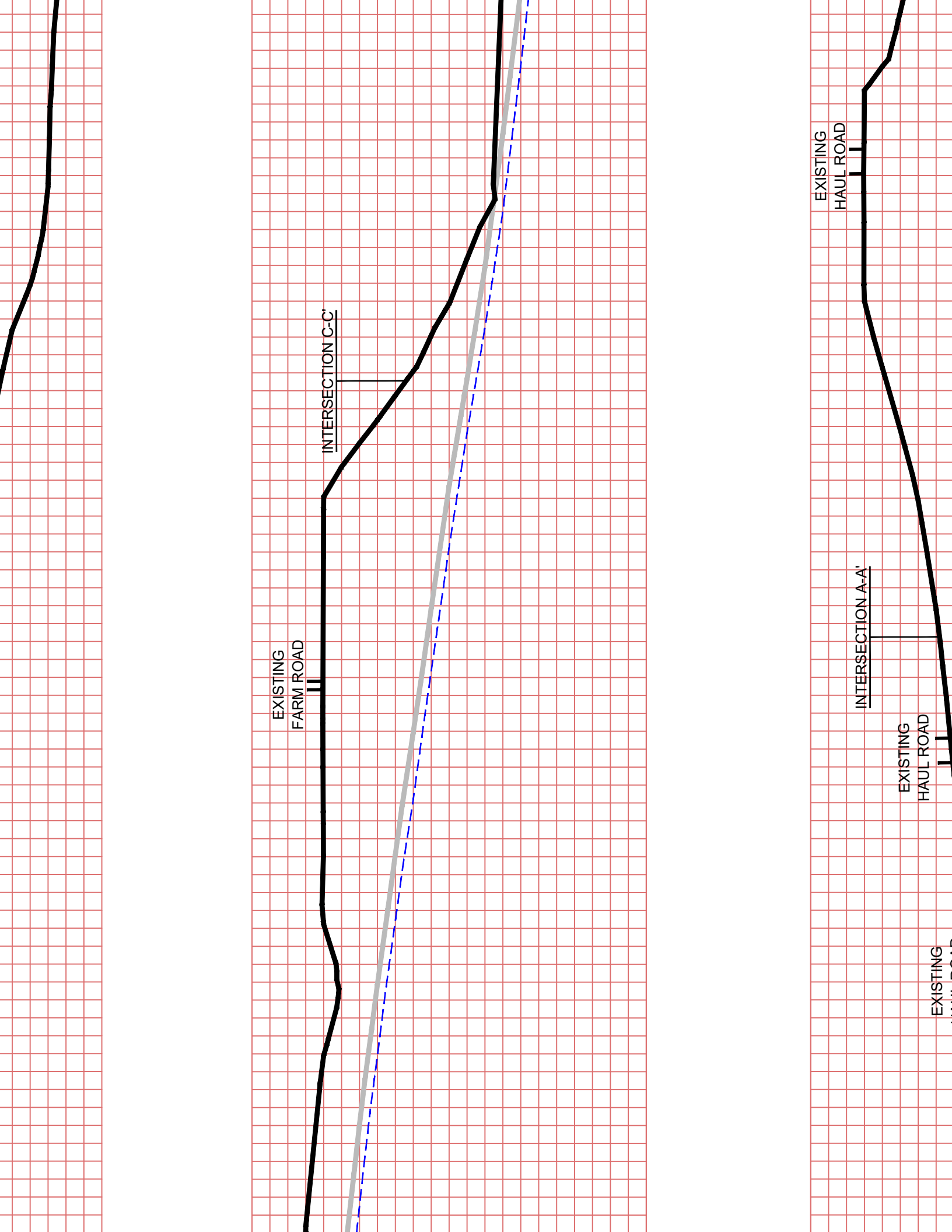

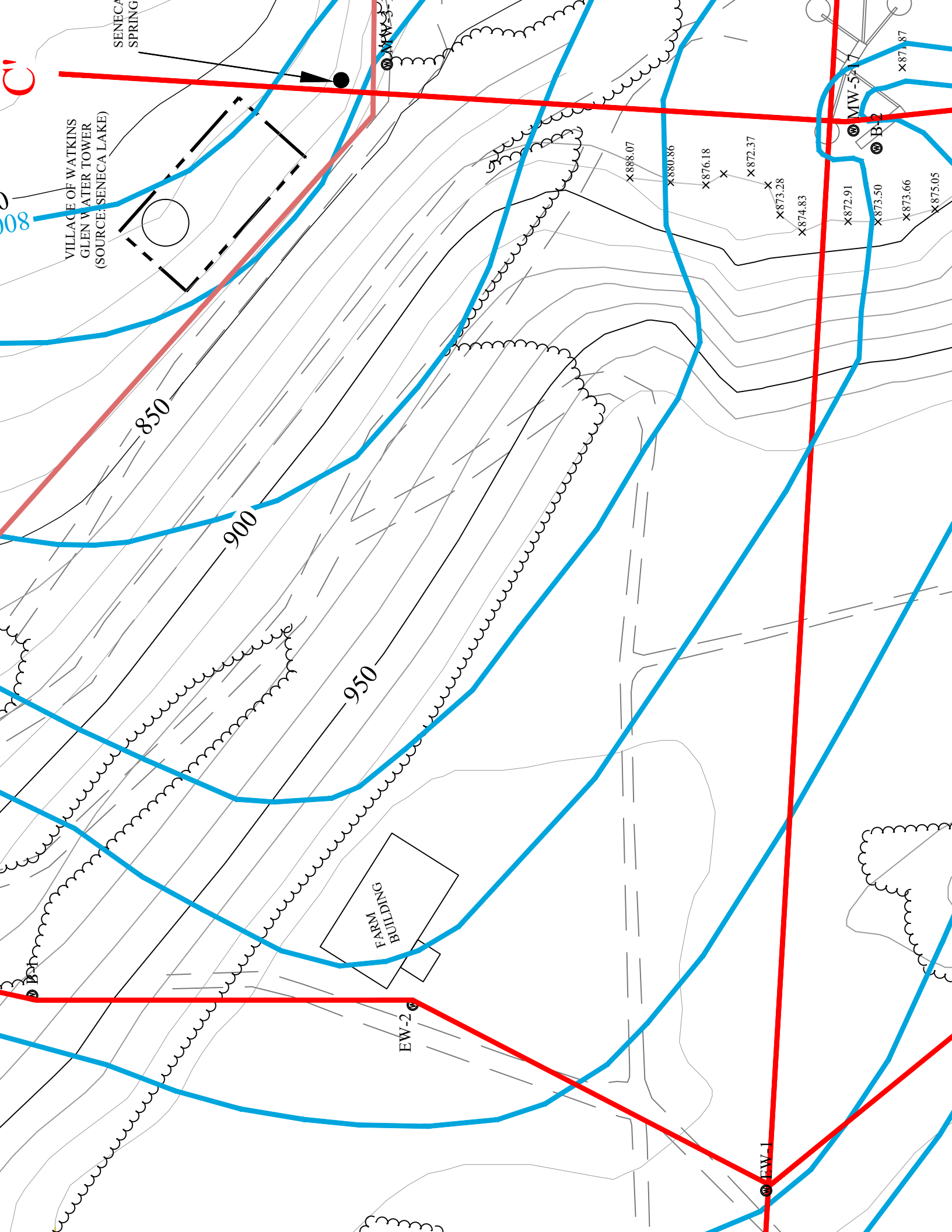

VILLAGE OF WATKINS
GLEN WATER TOWER
(SOURCE: SENECA LAKE)

SENeca
SPRING

FARM
BUILDING

EW-2

FW-1

MW-5-1

B-2

X888.07

X880.86

X876.18

X872.37

X873.28

X874.83

X872.91

X873.50

X873.66

X875.05

X871.87

850

900

950

08

C

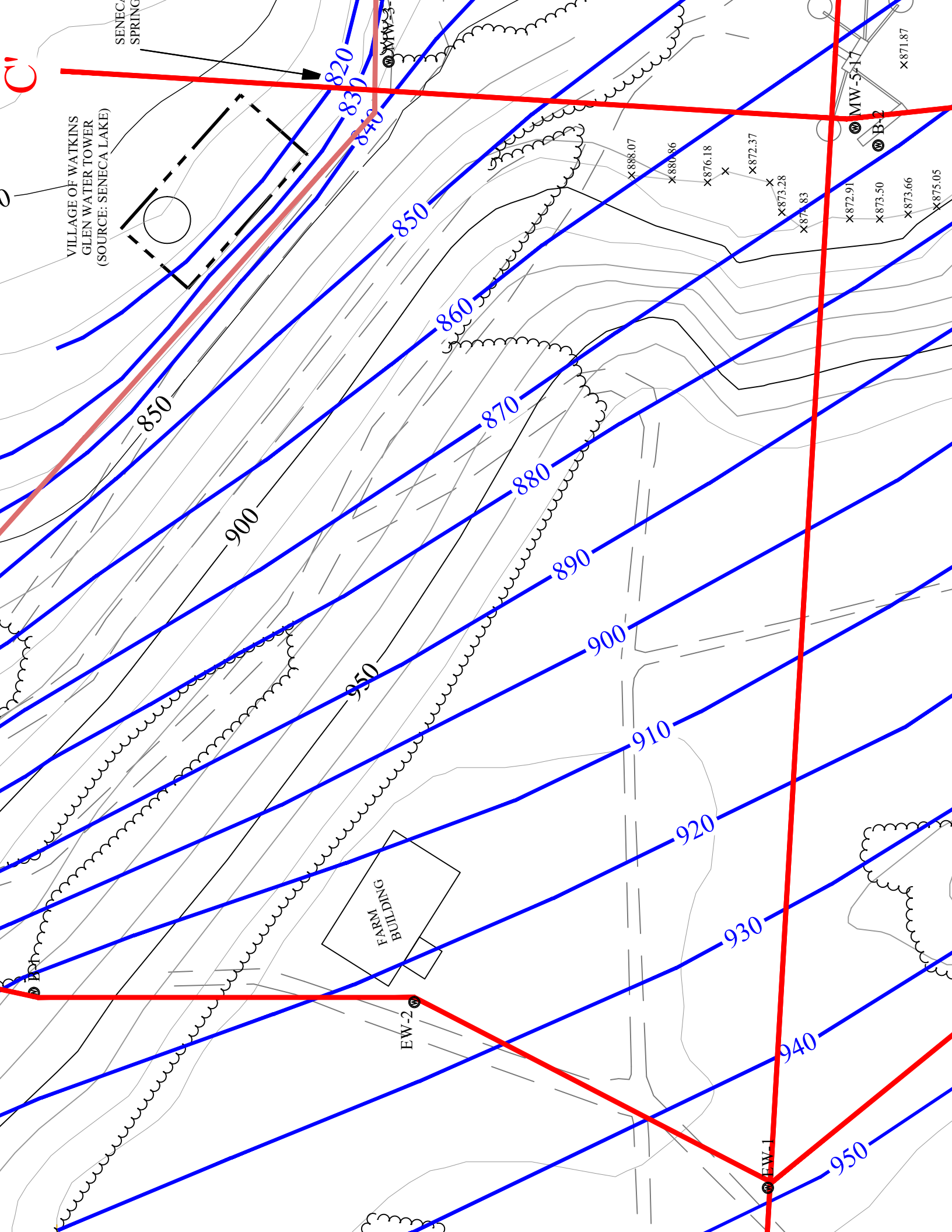

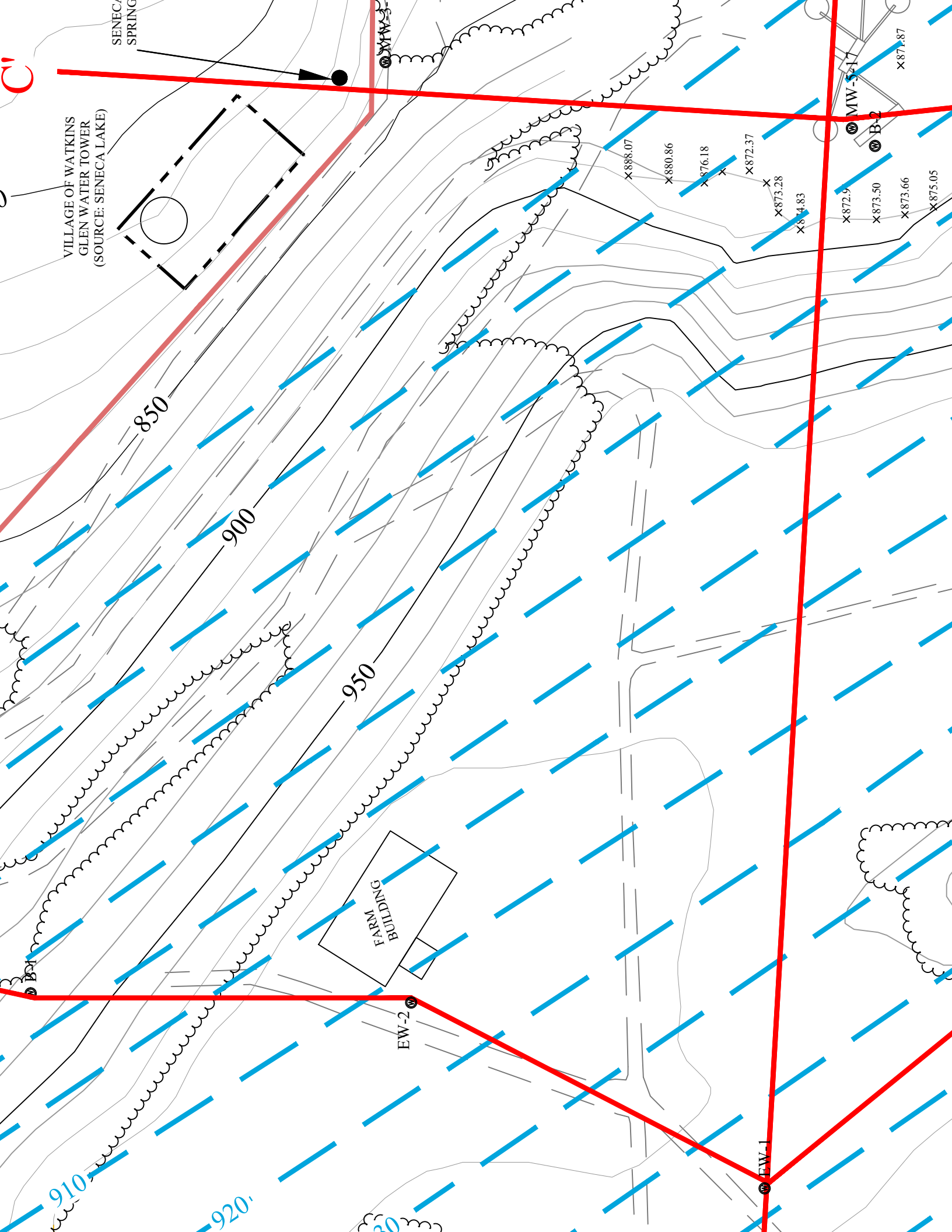

INTERSECTION A-A'

EW-2D

EW-1D
EW-1S

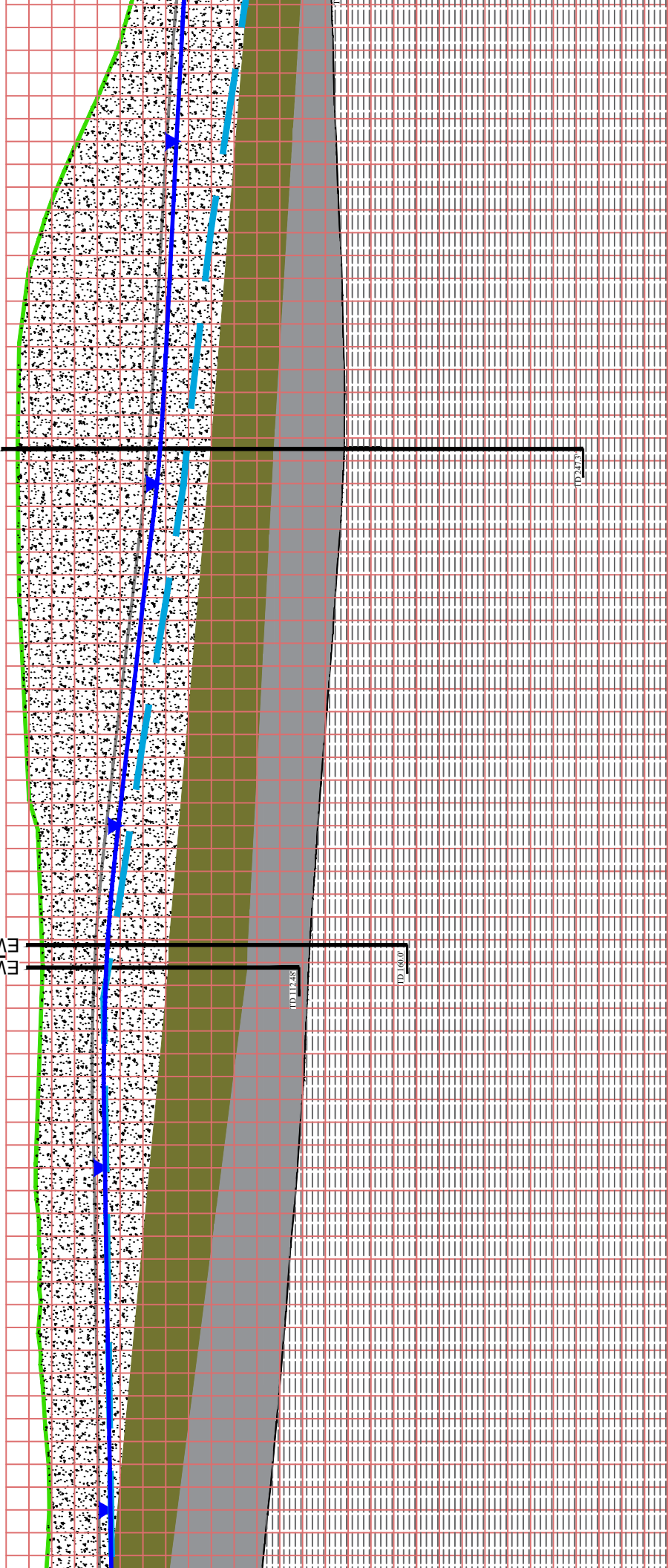

NORTH
C'

980
970
960
950

D AREA
BARY

INTERSECTION A-A'

SENECA LAKE

VILLAGE OF
WATKINS GLEN

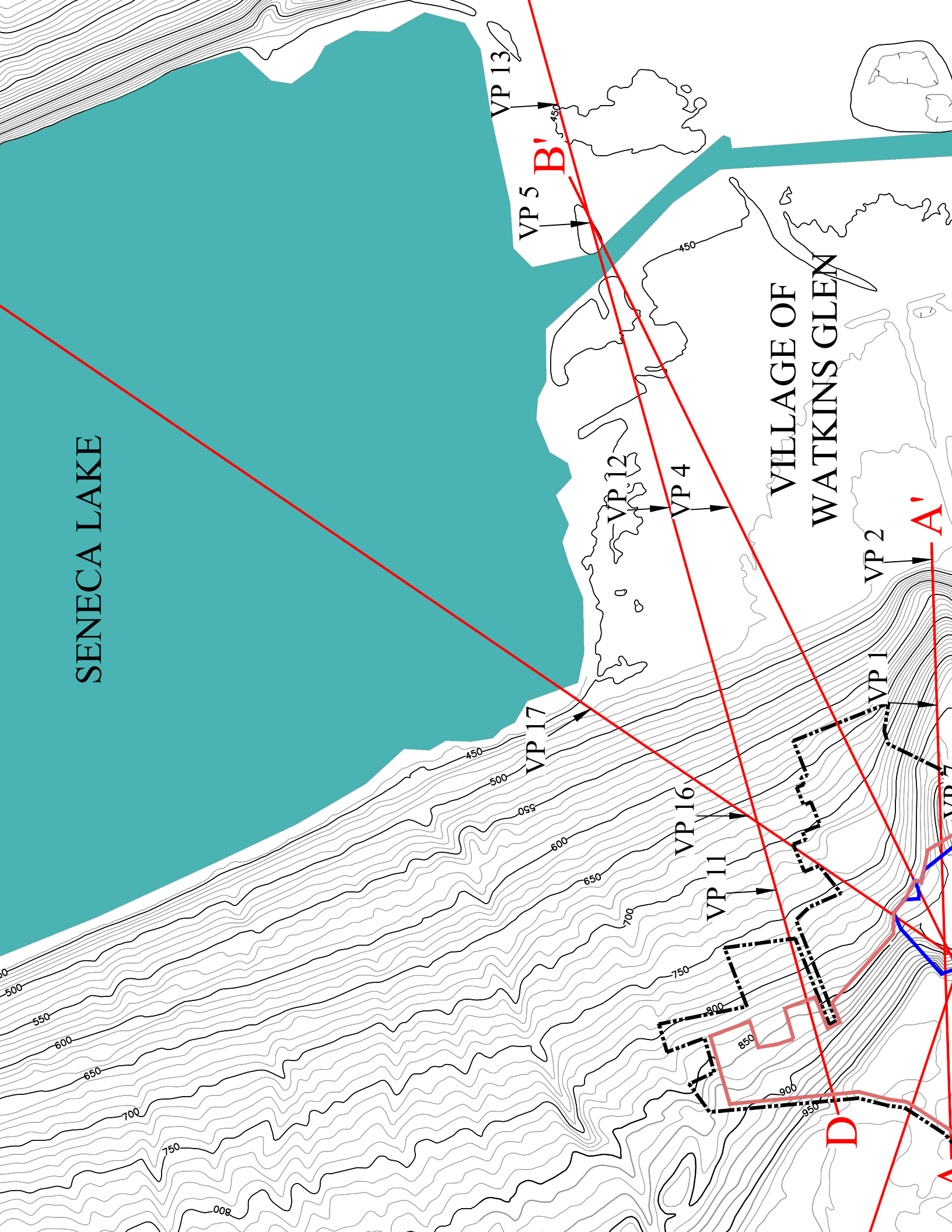

CURRENTLY APPROVED
AFFECTED AREA

PROPOSED EXPANSION
AFFECTED AREA

PROPOSED EXPANSION
AFFECTED AREA

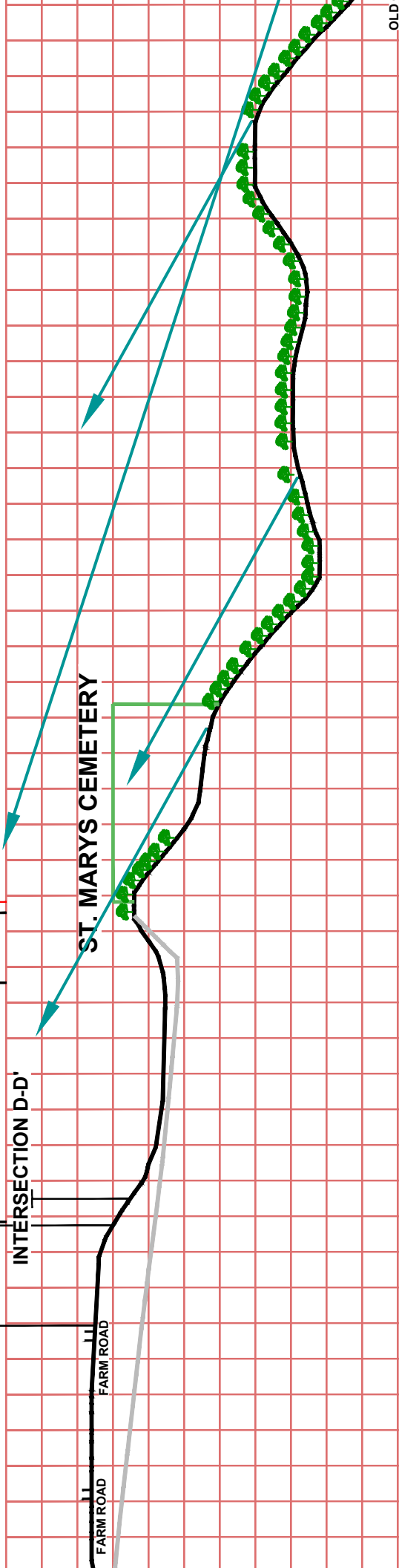
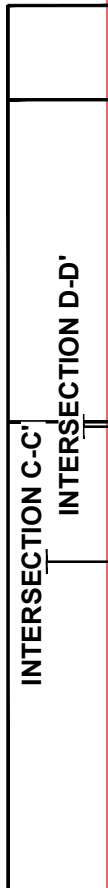

VIEW FROM ST. MARYS
CEMETERY
(VANTAGE POINT 7
484' TO PROPERTY LINE)

VIEW FROM WATKINS GLEN
STATE PARK TRAIL
(VANTAGE POINT 8
1,189' TO PROPERTY LINE)

VIEW FROM WATKINS GL
STATE PARK POOL
(VANTAGE POINT 9
2,188' TO PROPERTY LIN

INTERSECTION D-D'



DRAFT ENVIRONMENTAL IMPACT STATEMENT
It's Greener Now, Inc. – Padua Ridge Gravel Mine Town of Dix, New York

APPENDIX A

USFS ECOLOGICAL RESOURCE DOCUMENTATION



United States Department of the Interior



FISH AND WILDLIFE SERVICE
New York Ecological Services Field Office
3817 Luker Road
Cortland, NY 13045-9385

Phone: (607) 753-9334 Fax: (607) 753-9699

<http://www.fws.gov/northeast/nyfo/es/section7.htm>

In Reply Refer To:

August 16, 2021

Consultation Code: 05E1NY00-2017-SLI-3517

Event Code: 05E1NY00-2021-E-11776

Project Name: Padua Ridge Gravel Pit

Subject: Updated list of threatened and endangered species that may occur in your proposed project location or may be affected by your proposed project

To Whom It May Concern:

The enclosed species list identifies threatened, endangered, proposed and candidate species, as well as proposed and final designated critical habitat, that may occur within the boundary of your proposed project and/or may be affected by your proposed project. The species list fulfills the requirements of the U.S. Fish and Wildlife Service (Service) under section 7(c) of the Endangered Species Act (ESA) of 1973, as amended (16 U.S.C. 1531 *et seq.*). This list can also be used to determine whether listed species may be present for projects without federal agency involvement. New information based on updated surveys, changes in the abundance and distribution of species, changed habitat conditions, or other factors could change this list.

Please feel free to contact us if you need more current information or assistance regarding the potential impacts to federally proposed, listed, and candidate species and federally designated and proposed critical habitat. Please note that under 50 CFR 402.12(e) of the regulations implementing section 7 of the ESA, the accuracy of this species list should be verified after 90 days. This verification can be completed formally or informally as desired. The Service recommends that verification be completed by visiting the ECOS-IPaC site at regular intervals during project planning and implementation for updates to species lists and information. An updated list may be requested through the ECOS-IPaC system by completing the same process used to receive the enclosed list. If listed, proposed, or candidate species were identified as potentially occurring in the project area, coordination with our office is encouraged. Information on the steps involved with assessing potential impacts from projects can be found at: <http://www.fws.gov/northeast/nyfo/es/section7.htm>

Please be aware that bald and golden eagles are protected under the Bald and Golden Eagle Protection Act (16 U.S.C. 668 *et seq.*), and projects affecting these species may require development of an eagle conservation plan (http://www.fws.gov/windenergy/eagle_guidance.html). Additionally, wind energy projects should follow the Services wind

energy guidelines (<http://www.fws.gov/windenergy/>) for minimizing impacts to migratory birds and bats.

Guidance for minimizing impacts to migratory birds for projects including communications towers (e.g., cellular, digital television, radio, and emergency broadcast) can be found at: <http://www.fws.gov/migratorybirds/CurrentBirdIssues/Hazards/towers/towers.htm>; <http://www.towerkill.com>; and <http://www.fws.gov/migratorybirds/CurrentBirdIssues/Hazards/towers/comtow.html>.

We appreciate your concern for threatened and endangered species. The Service encourages Federal agencies to include conservation of threatened and endangered species into their project planning to further the purposes of the ESA. Please include the Consultation Tracking Number in the header of this letter with any request for consultation or correspondence about your project that you submit to our office.

Attachment(s):

- Official Species List
-

Official Species List

This list is provided pursuant to Section 7 of the Endangered Species Act, and fulfills the requirement for Federal agencies to "request of the Secretary of the Interior information whether any species which is listed or proposed to be listed may be present in the area of a proposed action".

This species list is provided by:

New York Ecological Services Field Office

3817 Luker Road

Cortland, NY 13045-9385

(607) 753-9334

Project Summary

Consultation Code: 05E1NY00-2017-SLI-3517

Event Code: 05E1NY00-2021-E-11776

Project Name: Padua Ridge Gravel Pit

Project Type: MINING

Project Description: Padua Ridge Gravel Pit, which is comprised of approximately 281± acres, is located east of Route 409 in the Town of Dix, Schuyler County, New York. The site is bound by Route 409 to the west, and Watkins Glen State Park and the Glen River to the southeast of the site. The mine proposes to expand current surface sand and gravel mining operations, from 14.33 to 106.27 acres. The mine is intended to continue to operate as a traditional surface extraction of unconsolidated sand and gravel, and will not involve removal of consolidated bedrock. A DEIS is being prepared for the proposed expansion project. The Final Scoping Document prepared by the NYSDEC outlines the necessity for inclusion of ecological resources within Watkins Glen State Park and Watkins Glen Gorge and whether these ecological resources will be impacted by the proposed mine expansion. The focus of the ecological resources is within the public lands, as shown by the location map.

Project Location:

Approximate location of the project can be viewed in Google Maps: <https://www.google.com/maps/@42.367168479879886,-76.90120937493359,14z>



Counties: Schuyler County, New York

Endangered Species Act Species

There is a total of 1 threatened, endangered, or candidate species on this species list.

Species on this list should be considered in an effects analysis for your project and could include species that exist in another geographic area. For example, certain fish may appear on the species list because a project could affect downstream species.

IPaC does not display listed species or critical habitats under the sole jurisdiction of NOAA Fisheries¹, as USFWS does not have the authority to speak on behalf of NOAA and the Department of Commerce.

See the "Critical habitats" section below for those critical habitats that lie wholly or partially within your project area under this office's jurisdiction. Please contact the designated FWS office if you have questions.

-
1. [NOAA Fisheries](#), also known as the National Marine Fisheries Service (NMFS), is an office of the National Oceanic and Atmospheric Administration within the Department of Commerce.

Flowering Plants

NAME	STATUS
Leedy's Roseroot <i>Rhodiola integrifolia ssp. leedyi</i> No critical habitat has been designated for this species. Species profile: https://ecos.fws.gov/ecp/species/285	Threatened

Critical habitats

THERE ARE NO CRITICAL HABITATS WITHIN YOUR PROJECT AREA UNDER THIS OFFICE'S JURISDICTION.



APPENDIX B

GEOLOGIC LOGS



BORING LOG

Boring No: MW-1-17

Project Name:	<u>Padua Ridge</u>	Project No:	<u>16157</u>
Client Name:	<u>It's Greener Now, Inc.</u>	Date:	<u>4/25/2017</u>
Location:	<u>3362 NY-409, Watkins Glen, NY 14891</u>	Logged By:	<u>DTS</u>
Weather/Temp:	<u></u>	Checked By:	<u></u>

Drilling Co:	<u>Parrat-Wolff, Inc.</u>	Depth:	<u>124'</u>
Driller:	<u>Glenn</u>	Equipment:	<u></u>
Date Started:	<u>4/25/2017</u>	Method:	<u>Auger & Air</u>
Date Ended:	<u>4/26/2017</u>	Depth/Datum:	<u>124' BGS</u>

Depth (ft)	Sample Depth	Blow Counts	DESCRIPTIVE LOG: color, grain size and amount, texture, moisture DEPOSITIONAL UNIT: outwash, till, lacustrine, muck, fill	REMARKS
0-5	NA	NA	Brown medium to fine sand, frequent pebbles, moist	Characterized by shavings, no split spoon sample taken
5-10	5-7	16-13 13-12	Brown medium to fine sand, some silt, frequent pebbles, loose	
10-15	10-12	10-11 9-12	Brown medium to fine sand, some silt, frequent pebbles, loose, moist	
15-20	15-17	7-8 7-10	Brown medium-fine sand, frequent pebbles, loose-moderately dense, moist	
20-25	20-22	4-10 7-9	Brown fine sand, few pebbles, moderately dense, moist	
25-30	25-27	9-15 17-12	Brown-gray medium to fine sand, some pebbles & cobbles, loose	
30-35	30-32	10-17 13-37	Brown-gray fine-medium sand, frequent pebbles & some cobbles, 1.5" brown clay lens, dry-moist, dense-moderately dense	
35-40	NA	50.0	Brown-gray fine-medium sand	Characterized by shavings, suspected split spoon refusal from large cobble
40-45	42-45	15-15 27-32	Brown-gray fine-medium sand, some silt, some pebbles & some cobbles, dry-moist, loose	
45-50	45-47	17-23 20-27	Brown-gray fine-medium sand, moderately dense, some pebbles, moist-dry	



BORING LOG

Boring No: MW-1-17

Project Name:	<u>Padua Ridge</u>	Project No:	<u>16157</u>
Client Name:	<u>It's Greener Now, Inc.</u>	Date:	<u>4/25/2017</u>
Location:	<u>3362 NY-409, Watkins Glen, NY 14891</u>	Logged By:	<u>DTS</u>
Weather/Temp:	<u></u>	Checked By:	<u></u>

Drilling Co:	<u>Parrat-Wolff, Inc.</u>	Depth:	<u>124'</u>
Driller:	<u>Glenn</u>	Equipment:	<u></u>
Date Started:	<u>4/25/2017</u>	Method:	<u>Auger & Air</u>
Date Ended:	<u>4/26/2017</u>	Depth/Datum:	<u>124' BGS</u>

Depth (ft)	Sample Depth	Blow Counts	DESCRIPTIVE LOG: color, grain size and amount, texture, moisture DEPOSITIONAL UNIT: outwash, till, lacustrine, muck, fill	REMARKS
50-55	50-52	18-29 32-33	Brown-gray fine-medium sand with silt, some pebbles moderately compact, moist	
55-60	55-57	25-25 29-30	Wet brown clay lenses (1.5 -2 "), gray-brown medium-fine sand with some silt, numerous pebbles and cobble fragments, moderately dense-loose	
60-65	60-62	17-25 45-30	Brown medium-fine sand with some silt , numerous pebbles, dry, moderately compact-loose	
65-70	65-67	45-30 26-34	Brown medium-fine sand with some silt, some pebbles, medium compact, moist-dry	
70-75	70-72	35-32 32-30	Brown medium-fine sand with some silt, some pebbles, medium compact, dry	
75-80	75-77	33-44 44-34	Gray-brown fine-medium sand, some silt, some pebbles, sandstone cobble, dry, moderately compact	
80-85	NA	NA	Brown Medium-fine sand.	Characterized by shavings, suspected split spoon refusal from large cobble
85-90	85-87		Gray-brown fine-medium sand, some silt, some pebbles, dry, moderately compact	
90-95	92-95	17-22 28-30	Brown medium-fine sand, few pebbles, moderately compact, moist	
95-100	95-97	11-14 12-14	Fine-medium brown sand to gray dense fine sand and silt, saturated, dense to very dense	



BORING LOG

Boring No: MW-1-17

Project Name:	<u>Padua Ridge</u>	Project No:	<u>16157</u>
Client Name:	<u>It's Greener Now, Inc.</u>	Date:	<u>4/27/2017</u>
Location:	<u>3362 NY-409, Watkins Glen, NY 14891</u>	Logged By:	<u>DTS</u>
Weather/Temp:	<u></u>	Checked By:	<u></u>

Drilling Co:	<u>Parrat-Wolff, Inc.</u>	Depth:	<u>124'</u>
Driller:	<u>Glenn</u>	Equipment:	<u></u>
Date Started:	<u>4/25/2017</u>	Method:	<u>Auger & Air</u>
Date Ended:	<u>4/26/2017</u>	Depth/Datum:	<u>124' BGS</u>

Depth (ft)	Sample Depth	Blow Counts	DESCRIPTIVE LOG: color, grain size and amount, texture, moisture DEPOSITIONAL UNIT: outwash, till, lacustrine, muck, fill	REMARKS
100-105	100-102	17-25 32-40	Moderately dense gray-brown silt with fine sand grading to very dense gray brown clay rich till, some pebbles, saturated	
105-110	105-107	50-3	Gray till dense to very dense, fully saturated	
110-115	110-112	75-2	Gray till dense to very dense, fully saturated	Switched to air drilling at 110' BGS
115-120	NA	NA	Gray till dense to very dense, fully saturated	No sample taken, tip of spoon lost in boring, successfully retrieved
120-124	120-122	50-2	Gray till dense to very dense, fully saturated, bedrock rock encounter at 121.5 BGS, drilled to 124 to confirm bedrock.	



BORING LOG

Boring No: MW-2-17

Project Name:	<u>Padua Ridge</u>	Project No:	<u>16157</u>
Client Name:	<u>It's Greener Now, Inc.</u>	Date:	<u>4/27/2017</u>
Location:	<u>3362 NY-409, Watkins Glen, NY 14891</u>	Logged By:	<u>DTS</u>
Weather/Temp:	<u></u>	Checked By:	<u></u>

Drilling Co:	<u>Parrat-Wolff, Inc.</u>	Depth:	<u>134'</u>
Driller:	<u>Glenn</u>	Equipment:	<u></u>
Date Started:	<u>4/27/2017</u>	Method:	<u>Auger & Air</u>
Date Ended:	<u>5/4/2017</u>	Depth/Datum:	<u>134' BGS</u>

Depth (ft)	Sample Depth	Blow Counts	DESCRIPTIVE LOG: color, grain size and amount, texture, moisture DEPOSITIONAL UNIT: outwash, till, lacustrine, muck, fill	REMARKS
0-5	NA	NA	Brown medium sand, some pebbles, moist	Characterized by shavings, no split spoon sample taken
5-10	5-7	6-7 8-10	Frequent pebbles, brown fine sand with moderate amount of silt, some clay, moist, dense	
10-15	10-12	12-45 50-3	Moist brown medium sand and with some pebbles, loose	Poor sample, spoon bounced on cobble
15-20	15-17	17-17 8-7	Medium brown sand, frequent pebbles, clay lenses 0.5" thick, some silt, moderately dense	
20-25	20-22	4-6 6-7	Brown-gray medium-coarse sand, moderate dense-loose, moist, some pebbles, 0.5" clay lenses	
25-30	25-27	10-17 20-18	Brown medium-fine sand, some pebbles, shale cobble, 2' clay and silt layer, moderately dense, moist	
30-35	30-32	20-11 16-20	Brown fine sand, some silt some pebbles, shale cobble, moist, loose	
35-40	35-37	21-16 14-18	brown medium-course sand, some pebbles, 2" silt and clay layer, dense-very dense	
40-45	40-42	4-8 15-17	Brown fine sand, some silt, some pebbles, shale cobble, moist, loose-moderately dense	
45-50	45-47	5-10 16-22	Brown fine sand, some silt, some pebbles, shale cobble, some compact and silty layers moist, loose-moderately dense	



BORING LOG

Boring No: MW-2-17

Project Name:	<u>Padua Ridge</u>	Project No:	<u>16157</u>
Client Name:	<u>It's Greener Now, Inc.</u>	Date:	<u>4/27/2017</u>
Location:	<u>3362 NY-409, Watkins Glen, NY 14891</u>	Logged By:	<u>DTS</u>
Weather/Temp:	<u></u>	Checked By:	<u></u>

Drilling Co:	<u>Parrat-Wolff, Inc.</u>	Depth:	<u>134'</u>
Driller:	<u>Glenn</u>	Equipment:	<u></u>
Date Started:	<u>4/27/2017</u>	Method:	<u>Auger & Air</u>
Date Ended:	<u>5/4/2017</u>	Depth/Datum:	<u>134' BGS</u>

Depth (ft)	Sample Depth	Blow Counts	DESCRIPTIVE LOG: color, grain size and amount, texture, moisture DEPOSITIONAL UNIT: outwash, till, lacustrine, muck, fill	REMARKS
50-55	50-52	16-12 17-21	Fine sand, some silt, moderately dense, some clay lenses, frequent pebbles, moist	
55-60	55-57	14-20 23-25	Fine with some medium brown sand, some silt and clay lenses, some pebbles, moderately dense, moist	
60-65	60-62	7-16 23-28	Brown-gray fine sand with some silt and clay, some pebbles, moist	
65-70	65-67	21-23 24-20	Brown fine-medium sand, some silt with clay layers, shale cobbles moderately dense, moist	
70-75	70-72	12-10 12-15	Brown fine-medium sand, some silt, shale cobbles moderately dense, moist	
75-80	75-77	30-41 38-32	Fine brown sand with some silt, some pebbles, loose-moderately dense	
80-85	80-82	15-30 11-12	Brown fine sand with some silt, numerous pebbles and cobbles, dry, loose.	
85-90	85-87	49-11 50-11	Brown fine sand with some silt, numerous pebbles and cobbles, dry, loose.	
90-95	92-95	15-30 29-40	Brown fine sand with some silt, numerous shale pebbles and cobbles, dry, moderately dense to loose	
95-100	95-97	15-28 45-50/4	Brown-gray fine sand with some silt, numerous pebbles and cobbles, dry, loose.	



BORING LOG

Boring No: MW-2-17

Project Name:	<u>Padua Ridge</u>	Project No:	<u>16157</u>
Client Name:	<u>It's Greener Now, Inc.</u>	Date:	<u>4/27/2017</u>
Location:	<u>3362 NY-409, Watkins Glen, NY 14891</u>	Logged By:	<u>DTS</u>
Weather/Temp:	<u></u>	Checked By:	<u></u>

Drilling Co:	<u>Parrat-Wolff, Inc.</u>	Depth:	<u>134'</u>
Driller:	<u>Glenn</u>	Equipment:	<u></u>
Date Started:	<u>4/27/2017</u>	Method:	<u>Auger & Air</u>
Date Ended:	<u>5/4/2017</u>	Depth/Datum:	<u>134' BGS</u>

Depth (ft)	Sample Depth	Blow Counts	DESCRIPTIVE LOG: color, grain size and amount, texture, moisture DEPOSITIONAL UNIT: outwash, till, lacustrine, muck, fill	REMARKS
100-105	100-102	26-33 38-37	Brown-gray fine sand with some silt, numerous pebbles and cobbles, dry, loose.	
105-110	NA	NA	Brown-gray fine sand with some silt, numerous pebbles and cobbles, dry, loose.	switched to air drilling with no sampling, characterized by blow out shavings
110-132	NA	NA	Brown fine-medium sand, dry	
132-133	NA	NA	Wet pebbles with some fine sand	
133-134	NA	NA	Brown-gray fine-medium sand with silt. Fully saturated/	



BORING LOG

Boring No: MW-3-17

Project Name:	<u>Padua Ridge</u>	Project No:	<u>16157</u>
Client Name:	<u>It's Greener Now, Inc.</u>	Date:	<u>4/25/2017</u>
Location:	<u>3362 NY-409, Watkins Glen, NY 14891</u>	Logged By:	<u>DTS</u>
Weather/Temp:	<u></u>	Checked By:	<u></u>

Drilling Co:	<u>Parrat-Wolff, Inc.</u>	Depth:	<u>32'</u>
Driller:	<u>Glenn</u>	Equipment:	<u></u>
Date Started:	<u>4/27/2017</u>	Method:	<u>Auger</u>
Date Ended:	<u>4/27/2017</u>	Depth/Datum:	<u>124' BGS</u>

Depth (ft)	Sample Depth	Blow Counts (per 6")	DESCRIPTIVE LOG: color, grain size and amount, texture, moisture DEPOSITIONAL UNIT: outwash, till, lacustrine, muck, fill	REMARKS
0-5	NA	NA	Brown medium sand, moist	Characterized by shavings, no split spoon sample taken
5-10	5-7	6-6 7-6	Brown medium sand, moist	Characterized by shavings, suspected split spoon refusal from large cobble
10-15	10-12	2-4 3-4	Brown silty fine sand, some pebbles, moist	
15-20	15-17	2-3 2-3	Fine-medium brown sand, some silt, 1.5" clay lenses half way through sample, some pebbles, saturated	
20-25	20-22	12-15 17-18	Musky brown fine-medium sand, clay and silt varves, frequent pebbles, very dense, saturated	
25-30	25-27	50-1	Musky brown fine-medium sand	Characterized by shavings, suspected split spoon refusal from large cobble
30-34	30-32		Fine brown sand with silt and clay, saturated, shale bedrock encountered at +/- 32 feet BGS	



BORING LOG

Boring No: MW-4-17

Project Name:	<u>Padua Ridge</u>	Project No:	<u>16157</u>
Client Name:	<u>It's Greener Now, Inc.</u>	Date:	<u>4/25/2017</u>
Location:	<u>3362 NY-409, Watkins Glen, NY 14891</u>	Logged By:	<u>DTS</u>
Weather/Temp:	<u></u>	Checked By:	<u></u>

Drilling Co:	<u>Parrat-Wolff, Inc.</u>	Depth:	<u>24'</u>
Driller:	<u>Glenn</u>	Equipment:	<u></u>
Date Started:	<u>4/28/2017</u>	Method:	<u>Auger</u>
Date Ended:	<u>4/28/2017</u>	Depth/Datum:	<u>24' BGS</u>

Depth (ft)	Sample Depth	Blow Counts (per 6")	DESCRIPTIVE LOG: color, grain size and amount, texture, moisture DEPOSITIONAL UNIT: outwash, till, lacustrine, muck, fill	REMARKS
0-5	NA	NA	Sand and gravel fill for parking area, non-native	Characterized by shavings, no split spoon sample taken
5-10	5-7	3-3 5-7	Brown medium sand, some pebbles, some silt, moist, likely emplaced fill above native soil	
10-15	10-12	4-5 17-12	Musky brown clay, silt, and fine sand, some pebbles, very dense, moist	
15-20	15-17	6-12 21-31	Musky brown clay, silt, and fine sand, some pebbles, very dense, moist	
20-24	20-22	7-26 150-3	Musky brown clay, silt, and fine sand, some pebbles, shale cobble, very dense, moist. Shale bedrock encountered at 23' bgs	Sample moist but water quickly entered bore hole



TEST BORING LOG

5879 FISHER ROAD
EAST SYRACUSE, N.Y. 13057

PROJECT *Padua Gravel Mine*

HOLE NO. *B2-D*

LOCATION *Geneva*

SURF. EL.

DATE STARTED

DATE COMPLETED

JOB NO. *#08035*

2/29/08

3/3/08

GROUND WATER DEPTH
WHILE DRILLING *81'*

N — NO. OF BLOWS TO DRIVE SAMPLER 12" W/140# HAMMER FALLING
30" — ASTM D-1586, STANDARD PENETRATION TEST

BEFORE CASING
REMOVED

C — NO. OF BLOWS TO DRIVE CASING 12" W/
"OR — % CORE RECOVERY

HAMMER FALLING

AFTER CASING
REMOVED

Geo f

CASING TYPE *H.S.A-6 1/4 - 44'*

4" Air Hammer 44' - 100'

SHEET OF

4" B.S.P. Grouted - 44'

1 - 3

DEPTH	SAMPLE DEPTH	SAMPLE NUMBER	C	SAMPLE DRIVE RECORD PER 6"	N	DESCRIPTION OF MATERIAL	STRATA CHANGE DEPTH
<i>5</i>							
	<i>3.0 - 7.0</i>	<i>1</i>		<i>7 - 19</i> <i>20 - 25</i>	<i>38</i>		
<i>10</i>							
	<i>10.0 - 12.0</i>	<i>2</i>		<i>5 - 17</i> <i>31 - 25</i>	<i>48</i>		
<i>15</i>							
	<i>15.0 - 17.0</i>	<i>3</i>		<i>17 - 36</i> <i>36 - 38</i>	<i>72</i>		
<i>20</i>							
	<i>20.0 - 22.0</i>	<i>4</i>		<i>15 - 22</i> <i>31 - 29</i>	<i>63</i>	<i>Brown pines wet F/sand</i> <i>Ernest</i>	<i>20.0</i>
<i>25</i>							
	<i>25.0 - 27.0</i>	<i>5</i>		<i>5 - 8</i> <i>16 - 15</i>	<i>24</i>	<i>Brown w/D wet F/sand</i>	<i>25</i>
<i>30</i>							
	<i>30.0 - 32.0</i>	<i>6</i>		<i>9 - 15</i> <i>10 - 23</i>	<i>31</i>		
<i>39</i>							
	<i>35.0 - 36.0</i>	<i>7</i>		<i>12 - 26</i> <i>56/2</i>			
<i>40</i>							



TEST BORING LOG

5879 FISHER ROAD
EAST SYRACUSE, N.Y. 13057

PROJECT *Padua Gravel Mine*

HOLE NO. *B-2 D*

LOCATION *Geneva*

SURF. EL.

DATE STARTED

DATE COMPLETED

JOB NO. *#08035*

2/29/08

3/3/08

GROUND WATER DEPTH
WHILE DRILLING *81'*

N — NO. OF BLOWS TO DRIVE SAMPLER 12" W/140# HAMMER FALLING
30" — ASTM D-1586, STANDARD PENETRATION TEST

BEFORE CASING
REMOVED

C — NO. OF BLOWS TO DRIVE CASING 12" W/
"OR — % CORE RECOVERY # HAMMER FALLING

AFTER CASING
REMOVED

98 f

CASING TYPE *U.S.A. 664-44'* *4" Air Hammer 44'-100'*

SHEET OF

4" B.I.P. grouted - 44'

2-3

DEPTH	SAMPLE DEPTH	SAMPLE NUMBER	C	SAMPLE DRIVE RECORD PER 6"	N	DESCRIPTION OF MATERIAL	STRATA CHANGE DEPTH
	<i>40.0-40.9</i>	<i>8</i>		<i>36-50.4</i>		<i>Grey marl D. + 11</i>	<i>42.5</i>
	<i>42.0-42.1</i>	<i>9</i>		<i>50/1</i>		<i>Top of Rock</i>	
<i>45</i>						<i>Grouted 4" B.I.P.</i>	<i>44'</i>
		<i>4"</i>				<i>45' - pipe 20 bags cement</i>	
			<i>Air</i>			<i>50 lbs. bentonite</i>	
			<i>Hammer</i>				
<i>55</i>							
<i>60</i>							
<i>65</i>							
<i>70</i>							
<i>75</i>							
<i>80</i>							



TEST BORING LOG

5879 FISHER ROAD
EAST SYRACUSE, N.Y. 13057

PROJECT *Padua Gravel Mine*

LOCATION *Geneva*

DATE STARTED

2/29/08

DATE COMPLETED

3/3/08

N — NO. OF BLOWS TO DRIVE SAMPLER 12" W/140# HAMMER FALLING
30" — ASTM D-1586, STANDARD PENETRATION TEST

C — NO. OF BLOWS TO DRIVE CASING 12" W/ # HAMMER FALLING
%OR — % CORE RECOVERY

Jef

HOLE NO. *B2-D*

SURF. EL.

JOB NO. *#08035*

GROUND WATER DEPTH WHILE DRILLING *81'*

BEFORE CASING REMOVED

AFTER CASING REMOVED

CASING TYPE *H.S.A. - 6 1/4" - 44'*

4" Air Hammer 44' - 100'

SHEET OF

3-3

4" B.I.P. Cased 44'

DEPTH	SAMPLE DEPTH	SAMPLE NUMBER	C	SAMPLE DRIVE RECORD PER 6"	N	DESCRIPTION OF MATERIAL	STRATA CHANGE DEPTH
<i>85</i>							
<i>90</i>							
<i>95</i>							
<i>100</i>							<i>100'</i>
						<i>Installed well to 100'</i>	<i>303</i>
						<i>used 10' 2" to 6" Slot PVC screen</i>	
						<i>92' 2" PVC riser</i>	
						<i>2 plugs</i>	
						<i>4" royer cover</i>	

PROJECT *Pedva Gravel Mine*

LOCATION *Genova*

DATE STARTED

3/3/08

DATE COMPLETED

3/4/08

N — NO. OF BLOWS TO DRIVE SAMPLER 12" W/140# HAMMER FALLING
30" — ASTM D-1586, STANDARD PENETRATION TEST

C — NO. OF BLOWS TO DRIVE CASING 12" W/ # HAMMER FALLING
"OR — % CORE RECOVERY

llc jr

HOLE NO. *DW-15*

SURF. EL.

JOB NO. *#08035*

GROUND WATER DEPTH
WHILE DRILLING

BEFORE CASING
REMOVED

AFTER CASING
REMOVED

CASING TYPE *U.S.A. - 4 1/4"*

SHEET *1-3*

DEPTH	SAMPLE DEPTH	SAMPLE NUMBER	C	SAMPLE DRIVE RECORD PER 6"	N	DESCRIPTION OF MATERIAL	STRATA CHANGE DEPTH
5							
	<i>5.0' - 7.0'</i>	<i>1</i>		<i>12-16</i> <i>15-16</i>	<i>31</i>	<i>Brown Moist Dense flk Gravel</i> <i>Some Silt Little flk Sand</i>	<i>8.0'</i>
10							
	<i>10.0' - 12.0'</i>	<i>2</i>		<i>4-5</i> <i>5-5</i>	<i>60</i>	<i>Brown Moist loose flk Sand</i>	<i>15'</i>
15							
	<i>15.0' - 17.0'</i>	<i>3</i>		<i>9-21</i> <i>18-13</i>	<i>45</i>	<i>Brown Moist Dense flk Sand base</i> <i>flk Gravel Little Silt</i>	<i>20'</i>
20							
	<i>20.0' - 22.0'</i>	<i>4</i>		<i>10-9</i> <i>8-12</i>	<i>17</i>	<i>Brown Moist H/Dense flk Sand and</i> <i>flk Gravel Little Silt</i>	<i>25'</i>
25							
	<i>25.0' - 27.0'</i>	<i>5</i>		<i>5-6</i> <i>8-8</i>	<i>14</i>	<i>Brown wet H/Dense flk Sand</i> <i>Little flk Gravel Trace Silt</i>	
30							
	<i>31.0' - 32.0'</i>	<i>6</i>		<i>5-6</i> <i>8-10</i>	<i>14</i>		<i>35'</i>
35							
	<i>35.0' - 37.0'</i>	<i>7</i>		<i>26-34</i> <i>10-11</i>	<i>44</i>	<i>Green Moist Hard Silt and Clay</i> <i>Some flk Sand Little flk Gravel</i>	
40							

25'
3/3



TEST BORING LOG

5879 FISHER ROAD
EAST SYRACUSE, N.Y. 13057

PROJECT *Paduz Gravel Mine*

LOCATION *Geneva*

DATE STARTED

3/3/08

DATE COMPLETED

3/4/08

HOLE NO. *DW-15*

SURF. EL.

JOB NO. *#08035*

GROUND WATER DEPTH
WHILE DRILLING

BEFORE CASING
REMOVED

AFTER CASING
REMOVED

N — NO. OF BLOWS TO DRIVE SAMPLER 12" W/140# HAMMER FALLING
30" — ASTM D-1586, STANDARD PENETRATION TEST

C — NO. OF BLOWS TO DRIVE CASING 12" W/ # HAMMER FALLING
"OR — % CORE RECOVERY

JLF

CASING TYPE *H.S.A. - 4 1/4"*

SHEET OF

2-3

DEPTH	SAMPLE DEPTH	SAMPLE NUMBER	C	SAMPLE DRIVE RECORD PER 6"	N	DESCRIPTION OF MATERIAL	STRATA CHANGE DEPTH
<i>45</i>	<i>40.0-42.0</i>	<i>8</i>		<i>20-16 18-25</i>	<i>34</i>		<i>45</i>
<i>50</i>	<i>45.0-47.0</i>	<i>9</i>		<i>7-11 16-28</i>	<i>27</i>	<i>Grey Moist M/Dense f/Sand Some Silt Trace f/Gravel.</i>	
<i>55</i>	<i>50.0-52.0</i>	<i>10</i>		<i>12-17 28-35</i>	<i>45</i>		<i>55.5</i>
<i>60</i>	<i>55.0-55.4</i>	<i>11</i>		<i>59</i>		<i>Grey Moist Hard Silt h.4 f/Gravel f/Secs</i>	
<i>65</i>	<i>60.0-60.3</i>	<i>12</i>		<i>50/2</i>			
<i>70</i>	<i>65.0-65.2</i>	<i>13</i>		<i>50/2</i>			<i>70</i>
<i>75</i>	<i>70.0-70.2</i>	<i>14</i>		<i>100/2</i>		<i>Grey Dry Hard Silt Little f/Gravel.</i>	
<i>80</i>	<i>75.0-75.4</i>	<i>15</i>		<i>50/4</i>			



TEST BORING LOG

5879 FISHER ROAD
EAST SYRACUSE, N.Y. 13057

PROJECT *Paduc Gravel Pit*

LOCATION *Geneva*

DATE STARTED

3/3/08

DATE COMPLETED

3/4/08

N — NO. OF BLOWS TO DRIVE SAMPLER 12" W/140# HAMMER FALLING
30" — ASTM D-1586, STANDARD PENETRATION TEST

C — NO. OF BLOWS TO DRIVE CASING 12" W/
"OR — % CORE RECOVERY

HAMMER FALLING

He F

HOLE NO. *DW-15*

SURF. EL.

JOB NO. *#08035*

GROUND WATER DEPTH
WHILE DRILLING

BEFORE CASING
REMOVED

AFTER CASING
REMOVED

CASING TYPE *H.S.A. - 4 1/8"*

SHEET OF
3-3

DEPTH	SAMPLE DEPTH	SAMPLE NUMBER	C	SAMPLE DRIVE RECORD PER 6"	N	DESCRIPTION OF MATERIAL	STRATA CHANGE DEPTH
85	80.0'-80.4'	16		50/4			
90	85.0'-85.4'	17		50/4			
95	90.0'-91.3'	18		50/3			93'
						<i>Brown Moist Hard S.H. Track f/Sand</i>	
100	95.0'-95.3'	19		50/3			
105	100.0'-100.5'	20		67			105'
110	105.0'-105.5'	21		57			
						<i>Brown Gray Moist Hard S.H. L. th Clay</i>	
115	110.0'-110.2'	22		100/2			115.5'
						<i>top of Rock? Boulder</i>	
	112.0'-112.1'	23		100/1			112.1'
						<i>Pulled auger's back to 65' Back-filled with pec gravel to 60' Bentonite seal 60' to 56' Set well at 55.2'</i>	130B

*20
JK*

Use 10' 2" 10 slot PVC Screen
47.2' 2" PVC riser
2 plugs

Sand pack and bentonite seal
Back filled with pea stone

TEST BORING LOG

5879 FISHER ROAD
EAST SYRACUSE, N.Y. 13057

PROJECT *Padua Gravel Mine*

LOCATION *Geneva*

DATE STARTED
3/5/08

DATE COMPLETED
3/6/08

HOLE NO. *B-35*

SURF. EL.

JOB NO. *#08035*

GROUND WATER DEPTH
WHILE DRILLING

N — NO. OF BLOWS TO DRIVE SAMPLER 12" W/140# HAMMER FALLING
30" — ASTM D-1586, STANDARD PENETRATION TEST

BEFORE CASING
REMOVED

C — NO. OF BLOWS TO DRIVE CASING 12" W/
"OR — % CORE RECOVERY

HAMMER FALLING
1st forcing

AFTER CASING
REMOVED

CASING TYPE *P.S.A. - 4 1/4"*

SHEET OF
1-

DEPTH	SAMPLE DEPTH	SAMPLE NUMBER	C	SAMPLE DRIVE RECORD PER 6"	N	DESCRIPTION OF MATERIAL	STRATA CHANGE DEPTH
5							
	<i>5.0'-7.0'</i>	<i>1</i>		<i>9-10 9-5</i>	<i>19</i>	<i>Brown moist medium dense fine sand Some fine gravel with silt</i>	<i>8.5'</i>
10							
	<i>10.0'-12.0'</i>	<i>2</i>		<i>36-12 18-10</i>	<i>30</i>	<i>Brown moist medium dense fine sand and fine gravel with silt</i>	
15							
	<i>15.0'-17.0'</i>	<i>3</i>		<i>17-15 14-16</i>	<i>29</i>		<i>18.5'</i>
20							
	<i>20.0'-21.4'</i>	<i>4</i>		<i>36-38 50/4</i>		<i>Brown moist medium dense fine gravel Cobbles some fine sand silt</i>	
25							
	<i>25.0'-25.4'</i>	<i>5</i>		<i>50/4</i>			
30							
	<i>30.0'-30.1'</i>	<i>6</i>		<i>50/1</i>			
35							
	<i>35.0'-35.9'</i>	<i>7</i>		<i>39-50/4</i>			
40							

*25'
3/5*



TEST BORING LOG

5879 FISHER ROAD
EAST SYRACUSE, N.Y. 13057

PROJECT *Padua Gravel Mine*

HOLE NO. *B-33*

LOCATION *Geneva*

SURF. EL.

DATE STARTED

DATE COMPLETED

JOB NO. *#08035*

3/5/08

3/6/08

GROUND WATER DEPTH
WHILE DRILLING

N — NO. OF BLOWS TO DRIVE SAMPLER 12" W/140# HAMMER FALLING
30" — ASTM D-1586, STANDARD PENETRATION TEST

BEFORE CASING
REMOVED

C — NO. OF BLOWS TO DRIVE CASING 12" W/ # HAMMER FALLING
"/OR — % CORE RECOVERY

AFTER CASING
REMOVED

He f

CASING TYPE *U.S.A. 4 1/4"*

SHEET OF

2 -

DEPTH	SAMPLE DEPTH	SAMPLE NUMBER	C	SAMPLE DRIVE RECORD PER 6"	N	DESCRIPTION OF MATERIAL	STRATA CHANGE DEPTH
<i>45</i>	<i>40.0'-42.0'</i>	<i>8</i>		<i>19-14</i>	<i>27</i>	<i>Brown wet medium fine Gravel and fine Sand some silt.</i>	<i>45'</i>
				<i>13-15</i>			
<i>50</i>	<i>45.0'-47.0'</i>	<i>9</i>		<i>5-7</i>	<i>18</i>	<i>Grey Brown wet medium fine Gravel</i>	
				<i>11-13</i>			
<i>55</i>	<i>50.0'-52.0'</i>	<i>10</i>		<i>6-9</i>	<i>23</i>		
				<i>14-10</i>			
<i>60</i>	<i>55.0'</i>	<i>11</i>					<i>60'</i>
<i>65</i>	<i>60.0'-62.0'</i>	<i>12</i>		<i>22-18</i>	<i>47</i>	<i>Red Brown moist hard silt with fine Gravel little clay trace</i>	
				<i>19-24</i>			
<i>70</i>	<i>65.0'-67.0'</i>	<i>13</i>		<i>22-26</i>	<i>51</i>		
				<i>25-38</i>			
<i>75</i>	<i>70.0'-71.8'</i>	<i>14</i>		<i>21-38</i>			<i>75'</i>
				<i>50/4</i>			
<i>80</i>	<i>75.0'-76.8'</i>	<i>15</i>		<i>50/4</i>		<i>Brown moist medium fine sand and silt with fine Gravel.</i>	



TEST BORING LOG

5879 FISHER ROAD
EAST SYRACUSE, N.Y. 13057

PROJECT *Padua Gravel Mine*

HOLE NO. *B-3 S*

LOCATION

SURF. EL.

DATE STARTED

DATE COMPLETED

JOB NO. *#08035*

3/5/08

3/6/

N — NO. OF BLOWS TO DRIVE SAMPLER 12" W/140# HAMMER FALLING
30" — ASTM D-1586, STANDARD PENETRATION TEST

GROUND WATER DEPTH
WHILE DRILLING

C — NO. OF BLOWS TO DRIVE CASING 12" W/
"OR — % CORE RECOVERY

HAMMER FALLING

BEFORE CASING
REMOVED

AFTER CASING
REMOVED

96 2

CASING TYPE *H.S.A. - 4 1/4"*

SHEET OF

3 - 3

DEPTH	SAMPLE DEPTH	SAMPLE NUMBER	C	SAMPLE DRIVE RECORD PER 6"	N	DESCRIPTION OF MATERIAL	STRATA CHANGE DEPTH
	<i>80.5 - 80.6'</i>	<i>16</i>		<i>48 - 50/1</i>			
<i>85.</i>	<i>83.5 - 83.6'</i>	<i>17</i>		<i>100/1</i>			<i>83.6'</i>
<i>90</i>						<i>Pulled augers back to 65'</i>	<i>1308</i>
						<i>Back filled hole with peastone</i>	
						<i>Bentonite seal 63' to 62'</i>	
						<i>Set well at 61'</i>	
						<i>used 10' 2" w slot pvc screen</i>	
						<i>53' 2" pvc riser</i>	
						<i>2 plugs</i>	

H2H Associates, LLC 179 River Street Troy, New York 12180 Tel. (518) 270-1620 Fax (518) 270-1672		WATER WELL INSTALLATION FORM	B-1
PROJECT: Padua Ridge Geologic Study		PROJECT NO.: 343.00	
CLIENT: It's Greener Now, Inc.		DATE DRILLED: 11/3/05 - 11/4/05	
LOCATION: Watkins Glen, New York		DATE DEVELOPED: 11/4/05	
DRILLING CONTRACTOR: Frey Well Drilling, Inc.		PURPOSE: Production Well	
INSPECTOR: Paul L. Sleasman			

Type: Water Well

Static Water Level: X Date: X

Measuring Point (M.P.): Top of Casing

Total Depth of Well: 84 ft bgs

Total Depth of Boring: 87 ft bgs

Drilling Method

Type: Air Rotary Diameter: 6-inch

Casing: 6 inch steel

Sampling Method

Type: NA Diameter: NA

Weight: NA Fall: NA

Interval: NA

Riser Pipe Left in Place

Material: steel Diameter: 6-inch I.D.

Length: 82 ft Joint Type: welded

Screen

Material: steel Diameter: 6-inch I.D.

Slot Size: 20-slot Length: 5 feet

Stratigraphic Unit Screened: Gravel

Filter Pack

Sand: _____ Gravel: X Natural: _____

Grade: 1/8 - 1/2 inch

Amount: 5 gal buckets (3) Interval: 79-84 ft bgs

Seal(s)

Type: _____ Interval: _____

Type: _____ Interval: _____

Type: _____ Interval: _____

Locking Casing: Yes No

Water Well Detail

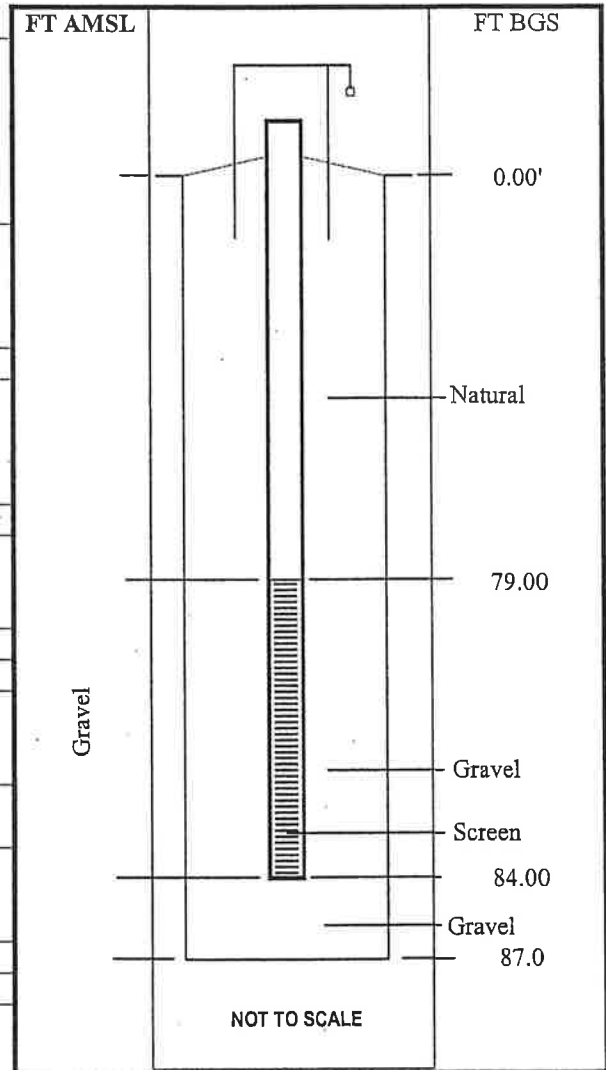

Notes: K-Packer type screen used, 5 ft 6 in long with 5 ft screened, telescoping.

H2H Associates, LLC	179 River Street Troy, New York 12180	TEST PIT LOG	TP-A
PROJECT: Padua Ridge Geologic Study		Sheet: 1 of 1	
CLIENT: It's Greener Now, Inc.		Job No.: 343.00	
PURPOSE: Characterize Geologic Setting		Meas. Pt. Elev.:	
EXCAVATION CONTRACTOR: It's Greener Now, Inc.		Ground Elev.:	
EXCAVATOR: CAT 320 L		Datum: NAD 83, NAVD 88	
GROUND WATER DEPTH: NA		Date Started: 10/31/05	
MEASURING POINT: Ground Surface		Date Finished: 10/31/05	
DATE OF MEASUREMENT: NA		Excavator: Jered Buckley	
ORIENTATION: NNE - SSW		Geologist: Paul Sleasman	

Depth (feet)	Sample	Geologic Description	Groundwater Information
0 1 2 3 4 5 6 7 8 9 10 11 12 13 14 15	1	Br Cy\$, s(+) cbbl, l bldr, l(-) cmf G; tight, moist.	No groundwater observed.
16 17 18 19 20		Same, turned gray.	No groundwater observed.
21 22 23 24 25		End of Test Pit Total Depth = 16 ft bgs No bedrock encountered. No groundwater encountered. Backfill pit with native material. GPS Coordinates: N 42° 22' 47.9" Accuracy = 24 ft. W 76° 53' 10.9"	

H2H Associates, LLC	179 River Street Troy, New York 12180	TEST PIT LOG	TP-B
PROJECT: Padua Ridge Geologic Study		Sheet: 1 of 1	
CLIENT: It's Greener Now, Inc.		Job No.: 343.00	
PURPOSE: Characterize Geologic Setting		Meas. Pt. Elev.:	
EXCAVATION CONTRACTOR: It's Greener Now, Inc.		Ground Elev.:	
EXCAVATOR: CAT 320 L		Datum: NAD 83, NAVD 88	
GROUND WATER DEPTH: ~4 ft bgs		Date Started: 10/31/05	
MEASURING POINT: Ground Surface		Date Finished: 10/31/05	
DATE OF MEASUREMENT: NA		Excavator: Jered Buckley	
ORIENTATION: NNE - SSW		Geologist: Paul Sleasman	

Depth (feet)	Sample	Geologic Description	Groundwater Information
0	1	Br f S, s cbbl, s bldr, l cmf G, t \$; loose, dry.	No Groundwater Observed.
		Cbbl, l br f S, l bldr, t \$; loose, dry - moist.	
10		Dkbr Cy\$, s(+) cbbl, l bldr, l cmf G, t(+) mf S; tight, moist.	Moist.
15			
20		<p>End of Test Pit Total Depth = 16 ft bgs No bedrock encountered. Groundwater encountered ~4 ft bgs. Backfill pit with native material.</p> <p>GPS Coordinates: N 42° 22' 46.0" Accuracy = 11 ft. W 76° 53' 9.70"</p> <p>Located ~200 ft south of TP-A off east side of access road.</p>	

H2H Associates, LLC		179 River Street Troy, New York 12180	TEST PIT LOG	TP-C
PROJECT: Padua Ridge Geologic Study			Sheet: 1 of 1	
CLIENT: It's Greener Now, Inc.			Job No.: 343.00	
PURPOSE: Characterize Geologic Setting			Meas. Pt. Elev.:	
EXCAVATION CONTRACTOR: It's Greener Now, Inc.			Ground Elev.:	
EXCAVATOR: CAT 320 L			Datum: NAD 83, NAVD 88	
GROUND WATER DEPTH: -5 ft bgs			Date Started: 10/31/05	
MEASURING POINT: Ground Surface			Date Finished: 10/31/05	
DATE OF MEASUREMENT: NA			Excavator: Jered Buckley	
ORIENTATION: N-S			Geologist: Paul Sleasman	
Depth (feet)	Sample	Geologic Description	Groundwater Information	
5	1	cmf cbbl, s br mf S, s cmf G, l bldr, t \$; loose.	Damp - moist	
		Br mf(+) S, s cmf cbbl, s cmf G, l bldr, t \$; loose.	Damp - moist	
		Dkbr Cy\$, l mf G, t f S; tight.	Groundwater seep observed at W side, -5 ft bgs.	
10		Br cmf S, s(+) cmf G, l(-) cbbl, t \$; v. loose.	Groundwater seep washing away west wall.	
15				
20		<p>End of Test Pit Total Depth = 16 ft bgs No bedrock encountered. Groundwater encountered -5 ft bgs. Backfill pit with native material.</p> <p>GPS Coordinates: N 42° 22' 43.7" Accuracy = 12 ft. W 76° 53' 9.50"</p> <p>Located ~200 ft south of TP-B off west side of access road.</p>		

H2H Associates, LLC	179 River Street Troy, New York 12180	TEST PIT LOG	TP-D
PROJECT: Padua Ridge Geologic Study			Sheet: 1 of 1
CLIENT: It's Greener Now, Inc.			Job No.: 343.00
PURPOSE: Characterize Geologic Setting			Meas. Pt. Elev:
EXCAVATION CONTRACTOR: It's Greener Now, Inc.			Ground Elev.:
EXCAVATOR: CAT 320 L			Datum: NAD 83, NAVD 88
GROUND WATER DEPTH: NA			Date Started: 10/31/05
MEASURING POINT: Ground Surface			Date Finished: 10/31/05
DATE OF MEASUREMENT: NA			Excavator: Jered Buckley
ORIENTATION: NNW - SSE			Geologist: Paul Sleasman

Depth (feet)	Sample	Geologic Description	Groundwater Information
0	1	Br cmf(+) S, s(-) cbb, s(-) cmf G, l bldr, t(+) \$, loose.	Damp
10		Same, dark brown.	Moist
15			
20		<p>End of Test Pit Total Depth = 16 ft bgs No bedrock encountered. No groundwater encountered. Backfill pit with native material.</p> <p>GPS Coordinates: N 42° 22' 41.10" Accuracy = 10 ft. W 76° 53' 7.70"</p> <p>Located ~200 ft south of TP-C off east side of access road.</p>	

H2H Associates, LLC		179 River Street Troy, New York 12180	TEST PIT LOG	TP-E
PROJECT: Padua Rldge Geologic Study			Sheet: 1 of 1	
CLIENT: It's Greener Now, Inc.			Job No.: 343.00	
PURPOSE: Characterize Geologic Setting			Meas. Pt. Elev:	
EXCAVATION CONTRACTOR: It's Greener Now, Inc.			Ground Elev.:	
EXCAVATOR: CAT 320 L			Datum: NAD 83, NAVD 88	
GROUND WATER DEPTH: NA			Date Started: 10/31/05	
MEASURING POINT: Ground Surface			Date Finished: 10/31/05	
DATE OF MEASUREMENT: NA			Excavator: Jered Buckley	
ORIENTATION: NNW - SSE			Geologist: Paul Sleasman	
Depth (feet)	Sample	Geologic Description	Groundwater Information	
0		Dkbr f S, s cmf G, t cbbl, t \$; loose.	Damp	
		Cbbl, s br m S, l cmf G; loose.	Dry - damp	
10	1	Br cmf(+) S, s cmf G, s cbbl; loose.	Dry - damp	
16		End of Test Pit Total Depth = 16 ft bgs No bedrock encountered. No groundwater encountered. Backfill pit with native material.		
20		GPS Coordinates: N 42° 22' 39.6" W 76° 53' 5.90" Accuracy = 20 ft. Located ~200 ft south of TP-D off east side of access road.		

H2H Associates, LLC	179 River Street Troy, New York 12180	TEST PIT LOG	TP-F
PROJECT: Padua Ridge Geologic Study			Sheet: 1 of 1
CLIENT: It's Greener Now, Inc.			Job No.: 343.00
PURPOSE: Characterize Geologic Setting			Meas. Pt. Elev:
EXCAVATION CONTRACTOR: It's Greener Now, Inc.			Ground Elev.:
EXCAVATOR: CAT 320 L			Datum: NAD 83, NAVD 88
GROUND WATER DEPTH: NA			Date Started: 10/31/05
MEASURING POINT: Ground Surface			Date Finished: 10/31/05
DATE OF MEASUREMENT: NA			Excavator: Jered Buckley
ORIENTATION: N-S			Geologist: Paul Sleasman

Depth (feet)	Sample	Geologic Description	Groundwater Information
	1	Br cmf S, s(+) cmf G, l cbbl, loose.	Damp - moist
		<p>End of Test Pit Total Depth = 16 ft bgs No bedrock encountered. No groundwater encountered. Backfill pit with native material.</p> <p>GPS Coordinates: N 42° 22' 37.7" W 76° 53' 3.10" Accuracy = 18 ft.</p> <p>Located ~200 ft SSE of TP-E off west side of access road (directly across intersection).</p>	

H2H Associates, LLC		179 River Street Troy, New York 12180	TEST PIT LOG	TP-G
PROJECT: Padua Ridge Geologic Study			Sheet: 1 of 1	
CLIENT: It's Greener Now, Inc.			Job No.: 343.00	
PURPOSE: Characterize Geologic Setting			Meas. Pt. Elev.:	
EXCAVATION CONTRACTOR: It's Greener Now, Inc.			Ground Elev.:	
EXCAVATOR: CAT 320 L			Datum: NAD 83, NAVD 88	
GROUND WATER DEPTH: NA			Date Started: 11/1/05	
MEASURING POINT: Ground Surface			Date Finished: 11/1/05	
DATE OF MEASUREMENT: NA			Excavator: Jered Buckley	
ORIENTATION: NE-SW			Geologist: Paul Sleasman	
Depth (feet)	Sample	Geologic Description	Groundwater Information	
5	1	Br cmf S, a(-) cmf G, l(+) mf cbbl, moderately loose.	Moist	
		Increased cobble content.	Moist	
10		Br cmf S, a(-) cmf G, l(+) mf cbbl, moderately loose.	Moist	
15				
20		<p>End of Test Pit Total Depth = 16 ft bgs No bedrock encountered. No groundwater encountered. Backfill pit with native material.</p> <p>GPS Coordinates: N 42° 22' 45.8" Accuracy = 8 ft. W 76° 53' 15.2"</p> <p>Located ~200 ft SW of pond near office. Good material.</p>		

H2H Associates, LLC		179 River Street Troy, New York 12180	TEST PIT LOG	TP-H
PROJECT: Padua Ridge Geologic Study			Sheet: 1 of 1	
CLIENT: It's Greener Now, Inc.			Job No.: 343.00	
PURPOSE: Characterize Geologic Setting			Meas. Pt. Elev.:	
EXCAVATION CONTRACTOR: It's Greener Now, Inc.			Ground Elev.:	
EXCAVATOR: CAT 320 L			Datum: NAD 83, NAVD 88	
GROUND WATER DEPTH: ~7 ft bgs			Date Started: 11/1/05	
MEASURING POINT: Ground Surface			Date Finished: 11/1/05	
DATE OF MEASUREMENT: NA			Excavator: Jered Buckley	
ORIENTATION: N-S			Geologist: Paul Sleasman	
Depth (feet)	Sample	Geologic Description	Groundwater Information	
5	1	Br cmf S, s(-) cmf G, s(-) cbbl, t \$; moderately loose to loose.	Moist	
		Increased gravel and cobble content.	Moist	
10	1	Br cmf S, s(-) cmf G, s(-) cbbl, t \$; moderately loose to loose.	-7 ft bgs - near wet	
15				
20		<p>End of Test Pit Total Depth = 16 ft bgs No bedrock encountered. Groundwater possible at -7 ft bgs. Backfill pit with native material.</p> <p>GPS Coordinates: N 42° 22' 44.7" Accuracy = 8 ft. W 76° 53' 15.3"</p> <p>Located ~100 ft S of TP-G. Good material.</p>		

H2H Associates, LLC	179 River Street Troy, New York 12180	TEST PIT LOG	TP-1
PROJECT: Padua Ridge Geologic Study			Sheet: 1 of 1
CLIENT: It's Greener Now, Inc.			Job No.: 343.00
PURPOSE: Characterize Geologic Setting			Meas. Pt. Elev.:
EXCAVATION CONTRACTOR: It's Greener Now, Inc.			Ground Elev.:
EXCAVATOR: CAT 320 L			Datum: NAD 83, NAVD 88
GROUND WATER DEPTH: ~7 ft bgs			Date Started: 11/1/05
MEASURING POINT: Ground Surface			Date Finished: 11/1/05
DATE OF MEASUREMENT: NA			Excavator: Jered Buckley
ORIENTATION: N-S			Geologist: Paul Sleasman

Depth (feet)	Sample	Geologic Description	Groundwater Information
5	1	Br cmf S, s cmf G, s mf cbbl, moderately loose to loose.	Damp ~4.5 ft bgs - moist
		Increased cobble content.	Moist
10		Br cmf S, s cmf G, s mf cbbl, moderately loose to loose.	Moist
		Increased cobble content.	Moist
15		Br cmf S, s cmf G, s mf cbbl, moderately loose to loose.	Moist
20		<p>End of Test Pit Total Depth = 16 ft bgs No bedrock encountered. No groundwater encountered. Backfill pit with native material.</p> <p>GPS Coordinates: N 42° 22' 43.1" W 76° 53' 12.7" Accuracy = 35 ft.</p> <p>Located ~100 ft S of TP-G. Good material.</p>	

H2H Associates, LLC

179 River Street
Troy, New York 12180
ph: 518.270-1620 fx: 518.270-1672

Test Boring Log

Boring No. B-1

PROJECT: Padua Ridge Geologic Study					Sheet 1 of 4
CLIENT: It's Greener Now, Inc.					Job No. 343.00
DRILLING CONTRACTOR: Frey Well Drilling, Inc.					Meas. Pt Elev: XXX
PURPOSE: Characterize Geologic Setting					Ground Elev: XXX
DRILLING METHOD: Air Rotary			SAMPLE	CORE	CASING
DRILL RIG TYPE: Foremost D-12			TYPE	chips	Steel
GROUNDWATER DEPTH: 49 ft & Rising			DIAM.		6 inch
MEASURING POINT: Top of Casing			WEIGHT		Driller: Bill Frey
DATE OF MEASUREMENT: 11:15 11/4/05			FALL		Inspector: Paul Sleasman

Depth (feet)	Sample Number	Time	Penetration Rate	Graphic Log	Geologic Description	Remarks
5	1		NA			
10					Br f S, s \$, l c(+)mf G; subangular, damp.	
15	2		NA		12': Gravel Encountered. 15': Br f S, a(-) c(+)mf G, l(-) \$; wet, subrounded.	
20					20': Gr c(+)mf G, l(-) \$, t f S; wet, subangular.	

H2H Associates, LLC

179 River Street
Troy, New York 12180
ph: 518.270-1620 fx: 518.270-1672

Test Boring Log

Boring No. B-1

PROJECT: Padua Ridge Geologic Study
CLIENT: It's Greener Now, Inc.
LOCATION: Watkins Glen, NY

Sheet 2 of 4

Job No. 343.00

Depth (feet)	Sample Number	Time	Penetration Rate	Graphic Log	Geologic Description	Remarks
25	3		NA		Same.	Moderate increase in variety of gravel types, with gray remaining dominant.
30	4		NA		Gr c(+)mf G, l(+) cmf S, l \$; wet.	Continued increase in other varieties of gravel.
40	5		NA		43'-48': Gr \$yC.	
45						

H2H Associates, LLC

179 River Street
Troy, New York 12180
ph: 518.270-1620 fx: 518.270-1672

Test Boring Log

Boring No. B-1

PROJECT: Padua Ridge Geologic Study

Sheet 3 of 4

CLIENT: It's Greener Now, Inc.

Job No. 343.00

LOCATION: Watkins Glen, NY

Depth (feet)	Sample Number	Time	Penetration Rate	Graphic Log	Geologic Description	Remarks
50	5 (cont)		NA		Gr c(+)mf G, s c(+)mf S, t(+) Cy\$; , subangular, wet.	
55	6		NA		Gr cmf G, l(-) \$; subangular - angular, wet.	
60	7		NA		65': Gr cmf G, s Cy\$; subangular - angular, wet.	11/4/2005
65	8		NA		Gr cmf G, l(-) Gr \$, subangular - angular, wet.	
70						

H2H Associates, LLC

179 River Street
Troy, New York 12180
ph: 518.270-1620 fx: 518.270-1672

Test Boring Log

Boring No. B-1

PROJECT: Padua Ridge Geologic Study

CLIENT: It's Greener Now, Inc.

LOCATION: Watkins Glen, NY

Sheet 4 of 4

Job No. 343.00

Depth (feet)	Sample Number	Time	Penetration Rate	Graphic Log	Geologic Description	Remarks
75	9		NA		71': Br \$yC; wet. 75': Br \$yC, l f S, l cmf G; subangular 76': Broken grey rock, rounded edges, flat, iron stained, producing ~10 gpm, highest yield and best overall quality seen at site during investigation. Boring is located almost directly upgradient of TP-C. 80': Same, iron stained shale gravel.	Duane (driller, 40+ years) calls it Beach Gravel, find it on benches above lake, seen just before bedrock.
85					86' : BEDROCK, Gray Shale.	
90					End of Boring. Total Depth = 87.0 ft bgs Depth to Water Measurements: 52 ft btoc @ 10:40 49 ft btoc @ 11:15 GPS Coordinates: N 42° 22' 41.7" Accuracy = 9 ft. W 76° 53' 11.1"	Convert boring to water well, see Well Construction Log for details.
95						

H2H Associates, LLC 179 River Street Troy, New York 12180 ph: 518.270-1620 fx: 518.270-1672				Test Boring Log			Boring No. B-2
PROJECT: Padua Ridge Geologic Study						Sheet 1 of 4	
CLIENT: It's Greener Now, Inc.						Job No. 343.00	
DRILLING CONTRACTOR: Frey Well Drilling, Inc.						Meas. Pt Elev: XXX	
PURPOSE: Characterize Geologic Setting						Ground Elev: XXX	
DRILLING METHOD: Air Rotary				SAMPLE	CORE	CASING	
DRILL RIG TYPE: Foremost D-12				TYPE	chips	Steel	
GROUNDWATER DEPTH: X				DIAM.		6 inch	
MEASURING POINT: Top of Casing				WEIGHT		Driller: Bill Frey	
DATE OF MEASUREMENT: X				FALL		Inspector: Paul Sleasman	
Depth (feet)	Sample Number	Time	Penetration Rate	Graphic Log	Geologic Description	Remarks	
5	1		NA				
10					Br cmf S, cmf G; subrounded, wet.		
15	2		NA				
20					Br Cy\$, s cmf G; subrounded, wet.		

H2H Associates, LLC

179 River Street
Troy, New York 12180
ph: 518.270-1620 fx: 518.270-1672

Test Boring Log

Boring No. B-2

PROJECT: Padua Ridge Geologic Study

CLIENT: It's Greener Now, Inc.

LOCATION: Watkins Glen, NY

Sheet 2 of 2

Job No. 343.00

Depth (feet)	Sample Number	Time	Penetration Rate	Graphic Log	Geologic Description	Remarks
25	3		NA		Same. 29': Br \$yC, l(-) cmf G, wet.	
30						
35	4		NA		Same. 34': Gr \$yC.	
40						
45	5				Same. 42': Br \$yC, l cmf G; angular, flat. 42.5': BEDROCK, Gray Shale. 43.5': Same.	GPS Coordinates: N 42° 22' 32.7" W 76° 52' 57.9" Accuracy = 20 ft.
					End of Boring. Total Depth = 43.5 ft	

H2H Associates, LLC 179 River Street Troy, New York 12180 ph: 518.270-1620 fx: 518.270-1672			Test Boring Log			Boring No. EW-1	
PROJECT: Padua Ridge Geologic Study					Sheet 1 of 7		
CLIENT: It's Greener Now, Inc.					Job No. 343.00		
DRILLING CONTRACTOR: Frey Well Drilling, Inc.					Meas. Pt Elev: XXX		
PURPOSE: Characterize Geologic Setting					Ground Elev: XXX		
DRILLING METHOD: Air Rotary				SAMPLE	CORE	CASING	Datum: NAD 83, NAVD 88
DRILL RIG TYPE: Foremost D-12			TYPE	chips		Steel	Date Started: 11/3/05
GROUNDWATER DEPTH: X			DIAM.			6 inch	Date Finished: 11/3/05
MEASURING POINT: Top of Casing			WEIGHT				Driller: Bill Frey
DATE OF MEASUREMENT: X			FALL				Inspector: Paul Sleasman
Depth (feet)	Sample Number	Time	Penetration Rate	Graphic Log	Geologic Description		Remarks
0	1		NA		Br Cy\$; damp.		
1							
2							
3							
4							
5							
6							
7							
8							
9							
10	2		NA		Br cmf(+) S, a cmf G, t \$; subangular subrounded, dry - damp.		10-20 ft: Good Gravel
11							
12							
13							
14							
15							
16							
17							
18							
19							
20							

H2H Associates, LLC

179 River Street
 Troy, New York 12180
 ph: 518.270-1620 fx: 518.270-1672

Test Boring Log

Boring No. EW-1

PROJECT: Padua Ridge Geologic Study

.Sheet 2 of 7

CLIENT: It's Greener Now, Inc.

Job No. 343.00

LOCATION: Watkins Glen, NY

Depth (feet)	Sample Number	Time	Penetration Rate	Graphic Log	Geologic Description	Remarks
25	3		NA			22': Wet
30					Br \$, l mf S, l c(+)mf G, l f Cbl; subangular, wet.	
35	4		NA		35-37': Gr \$yC.	
40					37-40': Gr c(+)mf G (weathered shale).	
45	5		NA		Grbr \$yC.	

H2H Associates, LLC

179 River Street
Troy, New York 12180
ph: 518.270-1620 fx: 518.270-1672

Test Boring Log

Boring No. EW-1

PROJECT: Padua Ridge Geologic Study

Sheet 3 of 7

CLIENT: It's Greener Now, Inc.

Job No. 343.00

LOCATION: Watkins Glen, NY

Depth (feet)	Sample Number	Time	Penetration Rate	Graphic Log	Geologic Description	Remarks
50	5 (cont)		NA		Grbr \$yC.	
55	6		NA		56': Gr G.	
60					Gr Cy\$, a cmf G, f cbbl; subangular.	
65	7		NA			
70					Gr cmf(+) G, s mf cbbl, f Cy\$; angular subangular, wet.	

H2H Associates, LLC

179 River Street
Troy, New York 12180
ph: 518.270-1620 fx: 518.270-1672

Test Boring Log

Boring No. EW-1

PROJECT: Padua Ridge Geologic Study

Sheet 4 of 7

CLIENT: It's Greener Now, Inc.

Job No. 343.00

LOCATION: Watkins Glen, NY

Depth (feet)	Sample Number	Time	Penetration Rate	Graphic Log	Geologic Description	Remarks
75	8		NA			
80					Gr cmf(+) G, l(+) Cy\$; subangular, wet.	
85	9		NA			
90						
95	10		NA		92': Gray weathered shale.	

H2H Associates, LLC

179 River Street
 Troy, New York 12180
 ph: 518.270-1620 fx: 518.270-1672

Test Boring Log

Boring No. EW-1

PROJECT: Padua Ridge Geologic Study

Sheet 5 of 7

CLIENT: It's Greener Now, Inc.

Job No. 343.00

LOCATION: Watkins Glen, NY

Depth (feet)	Sample Number	Time	Penetration Rate	Graphic Log	Geologic Description	Remarks
98	10 (cont)		NA		98': Gray shale.	
100						
105					Not Sampled.	
110						
115	11		NA			
120					Gr shale, s Cy\$; wet.	

H2H Associates, LLC

179 River Street
 Troy, New York 12180
 ph: 518.270-1620 fx: 518.270-1672

Test Boring Log

Boring No. EW-1

PROJECT: Padua Ridge Geologic Study

CLIENT: It's Greener Now, Inc.

LOCATION: Watkins Glen, NY

Sheet 6 of 7

Job No. 343.00

Depth (feet)	Sample Number	Time	Penetration Rate	Graphic Log	Geologic Description	Remarks
125	12		NA		Gray shale with clay laminations; wet.	
130						
135	13		NA		Gray SHALE; wet.	Bedrock
140						
145	14		NA		Same.	Bedrock

H2H Associates, LLC

179 River Street
 Troy, New York 12180
 ph: 518.270-1620 fx: 518.270-1672

Test Boring Log

Boring No. EW-1

PROJECT: Padua Ridge Geologic Study

Sheet 7 of 7

CLIENT: It's Greener Now, Inc.

Job No. 343.00

LOCATION: Watkins Glen, NY

Depth (feet)	Sample Number	Time	Penetration Rate	Graphic Log	Geologic Description	Remarks
150	14 (cont)				Gray SHALE,; wet.	Bedrock
155	15				Same.	Bedrock
160					End of Boring. Total depth = 160 ft bgs. No real water encountered, estimated maximum of 1 gpm, wetness on the way down believed to be from sand and gravel above.	
165					GPS Coordinates: N 42° 22' 34.6" Accuracy = 17 ft. W 76° 53' 14.1"	
170						

H2H Associates, LLC

179 River Street
Troy, New York 12180
ph: 518.270-1620 fx: 518.270-1672

Test Boring Log

Boring No. EW-2

PROJECT: Padua Ridge Geologic Study				Sheet 1 of 10
CLIENT: It's Greener Now, Inc.				Job No. 343.00
DRILLING CONTRACTOR: Frey Well Drilling, Inc.				Meas. Pt Elev: XXX
PURPOSE: Characterize Geologic Setting				Ground Elev: XXX
DRILLING METHOD: Air Rotary		SAMPLE	CORE	CASING
DRILL RIG TYPE: Foremost D-12		TYPE	chips	Steel
GROUNDWATER DEPTH: X		DIAM.		6 inch
MEASURING POINT: Top of Casing		WEIGHT		Driller: Bill Frey
DATE OF MEASUREMENT: X		FALL		Inspector: Paul Sleasman

Depth (feet)	Sample Number	Time	Penetration Rate	Graphic Log	Geologic Description	Remarks
5	1		NA		Dkbr f S, a(+) cmf G, l(+) \$; angular, moist.	
10	2		NA		Ltbr f(+)m S, a cmf G, t \$; angular - subangular, dry.	
15	3		NA		Br \$, a(-) cmf G, l cmf S; angular, wet.	Adding water @ 20' bgs for dust control.
20						

H2H Associates, LLC

179 River Street
 Troy, New York 12180
 ph: 518.270-1620 fx: 518.270-1672

Test Boring Log

Boring No. EW-2

PROJECT: Padua Ridge Geologic Study

Sheet 2 of 10

CLIENT: It's Greener Now, Inc.

Job No. 343.00

LOCATION: Watkins Glen, NY

Depth (feet)	Sample Number	Time	Penetration Rate	Graphic Log	Geologic Description	Remarks
28	3 (cont)		NA		Br \$, a(-) cmf G, l cmf S; angular, wet.	
29						
30						
31						
32						
33	4		NA		Not Sampled.	
34						
35						
36						
37						
38						
39						
40						
41						
42						
43	4		NA		cmf G, Br s \$, l mf(+) S; angular, wet.	
44						
45						

H2H Associates, LLC

179 River Street
 Troy, New York 12180
 ph: 518.270-1620 fx: 518.270-1672

Test Boring Log

Boring No. EW-2

PROJECT: Padua Ridge Geologic Study

Sheet 3 of 10

CLIENT: It's Greener Now, Inc.

Job No. 343.00

LOCATION: Watkins Glen, NY

Depth (feet)	Sample Number	Time	Penetration Rate	Graphic Log	Geologic Description	Remarks
50	5		NA		Same.	
55	6		NA		56-58': Br \$yC; wet.	
60	7		NA		58-64.5': c(+)mf G, s shale chips; wet.	
65	8		NA		Gray SHALE.	
70	9		NA		Gray SHALE, a Brgr \$yC; soft, weathered shale, wet.	

H2H Associates, LLC

179 River Street
 Troy, New York 12180
 ph: 518.270-1620 fx: 518.270-1672

Test Boring Log

Boring No. EW-2

PROJECT: Padua Ridge Geologic Study

.Sheet 4 of 10

CLIENT: It's Greener Now, Inc.

Job No. 343.00

LOCATION: Watkins Glen, NY

Depth (feet)	Sample Number	Time	Penetration Rate	Graphic Log	Geologic Description	Remarks
75	9 (cont)		NA		Gray SHALE, a Brgr \$yC; soft, weathered shale, wet.	70-80': Weathered shale and clay laminations, casing and rods sinking down under their own weight, encounter a little water and a variety of gravel types (granites, sandstones, limestones, ect.).
80	10		NA		Grbr C, a cmf G; wet.	
85	11		NA		Same.	
90						
95						

H2H Associates, LLC

179 River Street
Troy, New York 12180
ph: 518.270-1620 fx: 518.270-1672

Test Boring Log

Boring No. EW-2

PROJECT: Padua Ridge Geologic Study

Sheet 5 of 10

CLIENT: It's Greener Now, Inc.

Job No. 343.00

LOCATION: Watkins Glen, NY

Depth (feet)	Sample Number	Time	Penetration Rate	Graphic Log	Geologic Description	Remarks
100	12		NA		Same, increase in shale gravel.	
105	13		NA		Same, back to even mix of gravel types.	
110	14		NA		Same, abundant white quartz sandstone gravel.	
115	15		NA		Same, back to even mix of gravel types.	
120						

H2H Associates, LLC

179 River Street
 Troy, New York 12180
 ph: 518.270-1620 fx: 518.270-1672

Test Boring Log

Boring No. EW-2

PROJECT: Padua Ridge Geologic Study

Sheet 6 of 10

CLIENT: It's Greener Now, Inc.

Job No. 343.00

LOCATION: Watkins Glen, NY

Depth (feet)	Sample Number	Time	Penetration Rate	Graphic Log	Geologic Description	Remarks
125	15 (cont)		NA		Same.	
130	16		NA		Same.	
135	16		NA		135': Rdgr \$yC; wet.	
140	17		NA		143': Gray Shale.	Bedrock
145	17		NA			

H2H Associates, LLC

179 River Street
 Troy, New York 12180
 ph: 518.270-1620 fx: 518.270-1672

Test Boring Log

Boring No. EW-2

PROJECT: Padua Ridge Geologic Study

Sheet 7 of 10

CLIENT: It's Greener Now, Inc.

Job No. 343.00

LOCATION: Watkins Glen, NY

Depth (feet)	Sample Number	Time	Penetration Rate	Graphic Log	Geologic Description	Remarks
150	18		NA		Gray SHALE, very little water.	Install 6" steel casing to 148 ft bgs Bedrock
155	19		NA		Same.	Bedrock
160	20		NA		Same.	Bedrock
165						
170						

H2H Associates, LLC

179 River Street
Troy, New York 12180
ph: 518.270-1620 fx: 518.270-1672

Test Boring Log

Boring No. EW-2

PROJECT: Padua Ridge Geologic Study

Sheet 8 of 10

CLIENT: It's Greener Now, Inc.

Job No. 343.00

LOCATION: Watkins Glen, NY

Depth (feet)	Sample Number	Time	Penetration Rate	Graphic Log	Geologic Description	Remarks
175	20 (cont)		NA		Gray SHALE.	Bedrock
180						
185						
190	21		NA		Same.	Some very turbid gray water encountered at 180 ft bgs (~3 gpm). Driller (Bill Frey) says it feels like a clay seam. Bedrock
195						

H2H Associates, LLC

179 River Street
 Troy, New York 12180
 ph: 518.270-1620 fx: 518.270-1672

Test Boring Log

Boring No. EW-2

PROJECT: Padua Ridge Geologic Study

Sheet 9 of 10

CLIENT: It's Greener Now, Inc.

Job No. 343.00

LOCATION: Watkins Glen, NY

Depth (feet)	Sample Number	Time	Penetration Rate	Graphic Log	Geologic Description	Remarks
	22		NA		Gray SHALE.	Bedrock
200	23		NA		Same.	Bedrock
205						
210						
215						
220						

H2H Associates, LLC

179 River Street
Troy, New York 12180
ph: 518.270-1620 fx: 518.270-1672

Test Boring Log

Boring No. EW-2

PROJECT: Padua Ridge Geologic Study

CLIENT: It's Greener Now, Inc.

LOCATION: Watkins Glen, NY

Sheet 10 of 10

Job No. 343.00

Depth (feet)	Sample Number	Time	Penetration Rate	Graphic Log	Geologic Description	Remarks
225	24		NA		Same.	Bedrock
230						
235						
240						
245					End of Boring Total Depth = 240 ft bgs GPS Coordinates: N 42° 22' 37.8" Accuracy = 9 ft. W 76° 53' 10.7"	Not much water, attempt to hydrofracture by pressurizing entire length of boring, develop for ~15-20 minutes, end up with ~5_ gpm.



DRAFT ENVIRONMENTAL IMPACT STATEMENT
It's Greener Now, Inc. – Padua Ridge Gravel Mine Town of Dix, New York

APPENDIX C

NEW YORK NATURAL HERITAGE PROGRAM DOCUMENTATION

NEW YORK STATE DEPARTMENT OF ENVIRONMENTAL CONSERVATION

Division of Fish and Wildlife, New York Natural Heritage Program

625 Broadway, Fifth Floor, Albany, NY 12233-4757

P: (518) 402-8935 | F: (518) 402-8925

www.dec.ny.gov

August 24, 2017

Alexandra Carroll
Spectra
19 British American Blvd. W
Latham, NY 12110

Re: Padua Ridge Gravel Mine
County: Schuyler Town/City: Dix

Dear Ms. Carroll:

In response to your recent request, we have reviewed the New York Natural Heritage Program database with respect to the above project.

Enclosed is a report of rare animals and significant natural communities that our database indicates occur in the vicinity of the project site.

For most sites, comprehensive field surveys have not been conducted; the enclosed report only includes records from our database. We cannot provide a definitive statement as to the presence or absence of all rare or state-listed species or significant natural communities. Depending on the nature of the project and the conditions at the project site, further information from on-site surveys or other sources may be required to fully assess impacts on biological resources.

Our database is continually growing as records are added and updated. If this proposed project is still under development one year from now, we recommend that you contact us again so that we may update this response with the most current information.

The presence of the plants and animals identified in the enclosed report may result in this project requiring additional review or permit conditions. For further guidance, and for information regarding other permits that may be required under state law for regulated areas or activities (e.g., regulated wetlands), please contact the NYS DEC Region 8 Office, Division of Environmental Permits, as listed at www.dec.ny.gov/about/39381.html.

Sincerely,

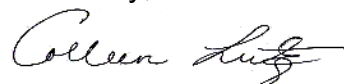

Colleen Lutz

Assistant Biologist

New York Natural Heritage Program

1040



The following rare animal and significant natural communities have been documented in the vicinity of the project site.

We recommend that potential onsite and offsite impacts of the proposed project on these species or communities be addressed as part of any environmental assessment or review conducted as part of the planning, permitting and approval process, such as reviews conducted under SEQRA. Field surveys of the project site may be necessary to determine the status of a species at the site, particularly for sites that are currently undeveloped and may still contain suitable habitat. Final requirements of the project to avoid, minimize, or mitigate potential impacts are determined by the lead permitting agency or the government body approving the project.

The following animal, while not listed by New York State as Endangered or Threatened, is of conservation concern to the state, and considered rare by the New York Natural Heritage Program.

<i>COMMON NAME</i>	<i>SCIENTIFIC NAME</i>	<i>NY STATE LISTING</i>	<i>HERITAGE CONSERVATION STATUS</i>
Dragonflies and Damselflies			
Gray Petaltail	<i>Tachopteryx thoreyi</i>	Special Concern	Imperiled in NYS

Watkins Glen, 0.1 mile south of the project site within Watkins Glen State Park 2012-06-11: Watkins Glen is a steep sided, west-east oriented, glacial gorge with numerous falls and plunge pools. Several small streams flow into the gorge and create year-round seepage areas on the south wall of the gorge. Some areas of the gorge are cool and moist; other areas are sunny and drier.

7608

The following significant natural communities are considered significant from a statewide perspective by the NY Natural Heritage Program. They are either occurrences of a community type that is rare in the state, or a high quality example of a more common community type. By meeting specific, documented criteria, the NY Natural Heritage Program considers these community occurrences to have high ecological and conservation value.

<i>COMMON NAME</i>	<i>NY STATE LISTING</i>	<i>HERITAGE CONSERVATION STATUS</i>
Calcareous Shoreline Outcrop		High Quality Occurrence of Rare Community Type
<p>Watkins Glen, 0.1 south of the project site within Watkins Glen State Park: The outcrop is large and sparsely vegetated within a 700-acre natural area that is surrounded by agriculture. The community has several exotic species whose spread may be somewhat controlled by repeated, seasonal scouring.</p>		
Hemlock-Northern Hardwood Forest		High Quality Occurrence
<p>Watkins Glen, 0.1 south of the project site within Watkins Glen State Park : This is a medium-sized, mature forest community with an 18-acre patch of old growth in good condition within a predominately agricultural landscape. A few exotic species are present, but not widespread within the community.</p>		
Shale Cliff and Talus Community		High Quality Occurrence of Uncommon Community Type

Watkins Glen, 0.1 south of the project site within Watkins Glen State Park: This is a large, shaded calcareous shale cliff and talus community that lines a deep gorge and is within a 700-acre natural area that is surrounded by agriculture. The cliff varies from approximately 15 to 120 feet (4 to 40 meters) in height and is associated with a broad band of talus shale along much of its length. Exotic species are present, but not particularly abundant on the cliff face or in the talus.

This report only includes records from the NY Natural Heritage database. For most sites, comprehensive field surveys have not been conducted, and we cannot provide a definitive statement as to the presence or absence of all rare or state-listed species. Depending on the nature of the project and the conditions at the project site, further information from on-site surveys or other sources may be required to fully assess impacts on biological resources.

If any rare plants or animals are documented during site visits, we request that information on the observations be provided to the New York Natural Heritage Program so that we may update our database.

Information about many of the rare animals and plants in New York, including habitat, biology, identification, conservation, and management, are available online in Natural Heritage's Conservation Guides at www.guides.nynhp.org, from NatureServe Explorer at www.natureserve.org/explorer, and from USDA's Plants Database at <http://plants.usda.gov/index.html> (for plants).

Information about many of the natural community types in New York, including identification, dominant and characteristic vegetation, distribution, conservation, and management, is available online in Natural Heritage's Conservation Guides at www.guides.nynhp.org. For descriptions of all community types, go to www.dec.ny.gov/animals/97703.html for Ecological Communities of New York State.



This location is in the vicinity of Rare Dragonflies and Damselflies Listed as Special Concern by NYS

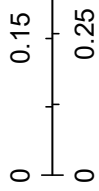



APPENDIX D

NOISE PROJECTION ANALYSIS



NOISE PROJECTION ANALYSIS

**IT'S GREENER NOW, INC.
PADUA RIDGE GRAVEL MINE
DIX, NEW YORK**

**NEW YORK STATE
DEPARTMENT OF ENVIRONMENTAL CONSERVATION
MLF # 80244**

Prepared for:

It's Greener Now, Inc.
3362 NYS Route 409
Watkins Glen, New York 14891

Prepared by:

JMT of New York, Inc.
19 British American Boulevard
Latham, New York 12110

Submitted: August 2021

Project No: 16-S0157N-001





TABLE OF CONTENTS

1.0	INTRODUCTION.....	1
2.0	SITE LOCATION.....	1
3.0	BACKGROUND	2
4.0	NOISE LEVELS	3
4.1	BACKGROUND NOISE LEVELS	4
4.2	FUTURE CONDITIONS.....	5
4.3	POTENTIAL IMPACTS & MITIGATION	6
5.0	CONCLUSION	7

TABLES

TABLE 1	AMBIENT NOISE MEASUREMENTS
TABLE 2	PROJECTED NOISE LEVELS

FIGURES

FIGURE 1	AMBIENT MONITORING LOCATIONS
FIGURE 2	EXISTING OPERATIONS
FIGURE 3	PROPOSED OPERATIONS
FIGURE 4	PROPOSED OPERATIONS – BERM MITIGATION - SCENARIO 1
FIGURE 5	PROPOSED OPERATIONS – BERM MITIGATION - SCENARIO 2

APPENDICES

APPENDIX A	AMBIENT NOISE MONITORING DATA
APPENDIX B	NOISE MODEL INPUT DATA



1.0 INTRODUCTION

It's Greener Now, LLC. (IGN) is proposing an expansion to IGN's sand and gravel mining operation in the Town of Dix, Schuyler County, New York known as the Padua Gravel Pit (Site). IGN owns approximately 281 acres at the Site. Of the 281 acres, 14.33 acres are currently permitted by the New York State Department of Environmental Conservation (NYSDEC) for mining and actively mined. This analysis was completed in support of a permit modification to include an additional 60.95 +/- acres, for a total of approximately 75.28 acres proposed for mining activity. This report supports a Draft Environmental Impact Statement for that action. Operations at the Site will continue to include all aspects of sand and gravel aggregate mining and processing.

This permit modification is a revision to an earlier application and includes a reduced footprint and depth of excavation. A previous noise impact assessment (Noise Assessment Report prepared by H2H Associates, LLC, April 2005, Revised February 28, 2007) for the prior application determined no potential impact, and the NYSDEC Final Scoping Outline for the DEIS which this report supports does not include noise impact assessment. The revised application and associated reduction in depth of mining may have the potential to reduce the associated topographic barrier attenuation at the Site margins. This report was prepared to assess changes in potential impacts resulting from that revision.

This report summarizes the basic principles of noise propagation as associated with the project. The report also makes projections of noise levels at receptors attributable to specific aspects of the project.

2.0 SITE LOCATION

The Site is located along New York State Route 409 in the Town of Dix, immediately west of the Village of Watkins Glen in Schuyler County, New York. Access to the Site is via an access road connected directly to NYS 409. IGN controls approximately 281 acres at this location with approximately 75.28 acres to ultimately be affected by mining operations. The mine site is bound by NYS Route 409 on the west, the lands of Watkins Glen State Park on the southwest, and the lands of St. Mary's Cemetery to the southeast.



3.0 BACKGROUND

Audible sound results when a sound source vibrates in the air. Specifically, sound is produced as a wave motion in air, or other media, by a mechanical disturbance. The vibration of an object produces longitudinal sound waves in the air, or other media, which radiate outward from the vibrating body much in the same manner that ripples spread out on the surface of a pond when a stone is thrown into it. This longitudinal wave propagation creates a fluctuation in the atmospheric pressure within the propagating media. These fluctuations in pressure are the sounds that are heard through the human ear. Sound pressure is the amplitude or measure of the difference between atmospheric pressure (with no sound present) and the total pressure (with sound present).

The sound pressure of an acoustic wave is measured in Pascals (Pa). The sound pressure level is measured in decibels (dB) where:

$$\text{dB} = 20 \log_{10}(P/P_{\text{ref}})$$

P = Sound pressure in pascals

P_{ref} = Reference pressure of 10⁻⁵ pascals

Because the range of sound intensities is so large the decibel scale is logarithmic. The range of audible sound pressures is extremely large. Specifically, sharply painful sound is roughly ten million times greater in pressure than the least audible sound. This pressure difference of 10 million pascals equates to approximately 140 decibels, when presented logarithmically.

Decibels are not added arithmetically. That is, two 60 decibel sounds do not equal a 120-decibel sound in intensity. In other words, the composite sound of two sewing machines operating at 60 dB each is not as loud as a single ambulance siren operating at 120 dB. Rather, sound levels are added logarithmically such that two 60 dB sounds total approximately 63 dB. If two sounds are of different levels, the lower level (in dB) adds less to the higher as this difference increases. If the difference between sound levels is 10 or more dB, the lower level adds almost nothing to the higher level. A 60 dB sound added to a 70 dB sound results in a total sound level of approximately 70.4 dB.

The rate at which a sound source vibrates, or makes the air vibrate, determines the frequency. Only pure harmonic tones (such as that produced by a tuning fork) have a single frequency. Most sounds consist of a wide spectrum of sound frequencies that when summed constitute the



sound heard. The range of frequencies that is audible to the human ear (approximately 20 to 20,000 Hz.) is divided into 10 octave bands. An octave is defined as the frequency range or interval whose upper frequency limit is twice the lower frequency limit. The ten octave bands each possess a “preferred frequency” at the center of the octave band. The octave band center frequencies are measured at approximately 31.5 Hz., 63 Hz., 125 Hz., 250 Hz., 500 Hz., 1,000 Hz., 2,000 Hz., 4,000 Hz., 8,000 Hz., and 16,000 Hz. The sound levels at each of these octave bands are then combined to achieve a total sound level for the audible range of frequencies. Depending on the type of noise or the type of receiver, octave band data may be averaged using a weighting which focuses on specific octave bands. When describing sound levels in relation to human hearing, an “A”-weighting is typically applied, resulting in a reading in dB(A) which focuses on frequencies that human hearing is most sensitive to.

Precipitation, wind fluctuations, wind gradients (with altitude), temperature, temperature gradients (with altitude), and relative humidity are atmospheric factors that influence sound propagation. Sound traveling with the wind is bent down to earth, while sound traveling against the wind is bent upward above the ground. There is little or no increase in sound levels due to the sound waves bent down; in fact, there is additional loss at the higher frequencies and at the greater distances. There can be noticeable reductions of sound levels (sometimes up to 20 to 30 decibels) at relatively long distances (beyond a few hundred yards) when the sound waves are bent upward, for sound traveling against the wind (for 10 to 20 mph wind speeds).

In addition to atmospheric factors, topography and vegetation also influence sound propagation. In general, sound from any point source decreases with distance by about 6 dBA with each doubling of the distance from the source. This is assuming that there are no obstructions in the linear path of the sound. The presence of vegetation, berms and intervening topography has an additive mitigating effect.

4.0 NOISE LEVELS

The site is an active sand and gravel mine with processing equipment. Noise generated during mining activity originates from the use of mobile equipment to clear and remove vegetation and overburden, removal and transport of material from active mine faces to processing facilities, operation of the processing facilities, and loading material for transport to market. The proposed



action includes an expansion in the area of mining. There are no proposed changes to equipment used at the site.

NYSDEC's Program Policy – Assessing and Mitigating Noise Impacts (February 2001) specifies noise performance standards for facilities should be based on community character. The area surrounding the facility is a mix of rural residential, agricultural and forested land.

In order to determine the level of any potential noise impacts from an expansion in mining area, a comparison was made between operational noise levels from currently-approved mining practices at the site (“background”), and a future operating scenario contemplating simultaneous operation of mining activity at several locations (“worst-case” scenario). This analysis was completed using SoundPLAN, a three-dimensional noise planning and modeling software. SoundPLAN utilizes octave band source data, topography, ground cover, and background environmental ambient conditions to model the noise regime in three dimensions.

The potential impact analysis below compares equivalent continuous sound level (Leq), in dB(A). Leq is a standard metric for comparing average relative sound levels, and is the primary metric referenced in NYSDEC's Program Policy – Assessing and Mitigating Noise Impacts.

Sound levels were modeled at four (4) residential receptors. These receptors were selected to represent conservative, “worst-case” scenarios with respect to potential impact.

4.1 BACKGROUND NOISE LEVELS

Environmental ambient sound levels were recorded at three (3) different locations within and around the Site while no mining activity was taking place. Ambient levels were collected over 30-minute intervals and are reported as equivalent continuous sound levels (Leq) in dB(A). Results from these measurements are summarized in Table 1. Appendix A contains instrument data from the ambient noise survey. The ambient noise monitoring locations are indicated on Figure 1. Principal sources of noise generation contributing to the ambient levels near the site include traffic on NYS Route 409, agricultural equipment associated with the Site and with adjacent properties, and insect and bird activity. The measured ambient noise levels ranged from 52.3 dB(A) to 57.9 dB(A), consistent with typical daytime rural ambient noise levels.



To determine the background condition for comparison to projected future conditions, operating conditions were modeled in SoundPLAN in order to provide a direct comparison to a future proposed condition, which would also be modeled in SoundPLAN. To be conservative, a minimum environmental ambient noise level of 52.0 dB(A) (below the lowest observed environmental ambient) was assumed, and combined with the existing operations modeled in SoundPLAN. The existing operations model was completed using source data from industry standard equipment, and is illustrated on Figure 2 and summarized in Table 2. Tabulated source input data is included in Appendix B. Modeled sound sources include mobile excavation equipment, stationary processing equipment, and haul trucks, as depicted on Figure 2. The model produced background noise levels, including existing operations, ranging from 52.4 dB(A) to 61.6 dB(A).

4.2 FUTURE CONDITIONS

The proposed operation will include an expansion in mining area, but not a significant increase in the mine's production rate, and therefore there are no proposed changes to equipment used at the site that will contribute to the sound sources. To demonstrate a worst-case scenario under the proposed operations, mobile equipment was modeled operating at two (2) locations simultaneously, at the margins of proposed excavation activity, and in close proximity to the most proximal adjacent receptors. The proposed operations condition was modeled in SoundPLAN using the same source equipment data as the existing background condition. The results of the proposed operations model are illustrated on Figure 3, and summarized in Table 2. Without additional mitigation, the proposed operations, as modeled under a worst-case scenario, range from 58.0 dB(A) to 67.3 dB(A), reflecting potential increases in observed sound levels of up to 10.2 dB(A) at some adjacent receptors. Receptor 2 demonstrates a potential reduction in anticipated noise levels, due to changes in topography resulting from the proposed modification. An additional scenario (Figure 5) was generated simulating operations as the mine approaches the southeast corner, 250 ft from a receptor at a trail (Receptor 4) within Watkins Glen State Park. The results of the additional scenario are also summarized in Table 2. Receptor 4 has a maximum potential sound increase of 0.5 dB(A). This potential increase in sound is considered "unnoticed to tolerable" by the NYSDEC, and therefore mitigation is not necessary.



4.3 POTENTIAL IMPACTS & MITIGATION

Per NYSDEC's Program Policy – Assessing and Mitigating Noise Impacts, sound level increases of under 5 dB are considered “unnoticed to tolerable”. As indicated by the analysis above, maximum sound level increases at the adjacent receptors will generally be on the order of up to 10.2 dB(A) and require further mitigation. In order to limit potential noise and visual impacts to Receptors 1 and 3, additional screening berms will be located at the southwest and north margins of the site. These new screening berms are illustrated on Figure 4 and were modeled in SoundPLAN to determine the mitigation value. As evidenced by the data in Table 2 and the depiction on Figure 4, the berms significantly reduce the potential for impacts at Receptor 1 and 3, even under worst-case scenarios. The resulting mitigated sound levels at Receptors 1 and 3 are 56.9 dB(A) and 63.1 dB(A) respectively, increases of 4.5 dB(A) and 3.2 dB(A) over background conditions. These lower levels meet the NYSDEC's definition of “unnoticed to tolerable” and will require no further mitigation efforts.

Although predicted noise levels associated with the proposed action show no significant increase in sound levels, several noise reduction techniques will continue to be employed to minimize observable noise at off-site receptors:

1. All equipment is muffled to MSHA standards;
2. Vegetative cover is retained in all areas outside the mine and stockpile areas that are not being mined or prepared for mining;
3. Natural barriers created by the active faces and overburden berms act as barriers to mitigate off-site noise levels when equipment is operating.

All plant employees and equipment operators are instructed in the operation of equipment to reduce noise. Below is a list of techniques utilized at the site to reduce noise:

1. Employees are instructed in the proper operation and maintenance of all equipment;
2. Employees are instructed not to "race" the engines of any equipment unnecessarily;



3. Employees are instructed to report any operating irregularities in equipment that may increase the level of noise generated by that equipment;
4. Vehicle speeds are controlled to reduce engine and ground noise during interior transport of material; and
5. All plant equipment is properly maintained and secured.

5.0 CONCLUSION

NYSDEC's program policy Assessing and Mitigation Noise Impacts states that increases in sound pressure of 0-5 dB(A) are unnoticeable to tolerable to human hearing. The noise projection analysis modeled impacts under worst case scenarios and resulted in potential increases to two (2) of three (3) proximal adjacent receptors of up to 4.5 dB(A). Sound level increases of no more than 4.5 dB(A), an unnoticeable to tolerable change in sound level. No additional mitigation is required.



TABLES

Table 1: Ambient Noise Measurements

Location	Measured Ambient (dBA)*
A1	52.3
A2	55
A3	57.9

*Ambient noise level measured by JMT of New York, Inc. 12. Levels presented as LAeq measured over half hour periods

Table 2: Projected Noise Levels

Location	Baseline Ambient (dB(A))	Existing Operations (dB(A))	Proposed Operations (dB(A))	Proposed Operations Mitigated-Scenario 1 (dB(A))	Proposed Operations Mitigated-Scenario 2 (dB(A))	Maximum Potential Sound Level Increase (dB(A))
R1: 3320 State Route 409	52	52.4	62.6	56.9	56.4	4.5
R2: Glen Valley Apartments	52	61.6	58.0	58.0	58.1	NA
R3: 3400 Division Street	52	59.9	67.3	63.1	63.1	3.2
R4: Watkins Glen State Park- Indian Trail Overlook	53	52.3	52.4	52.4	52.8	0.5



FIGURES

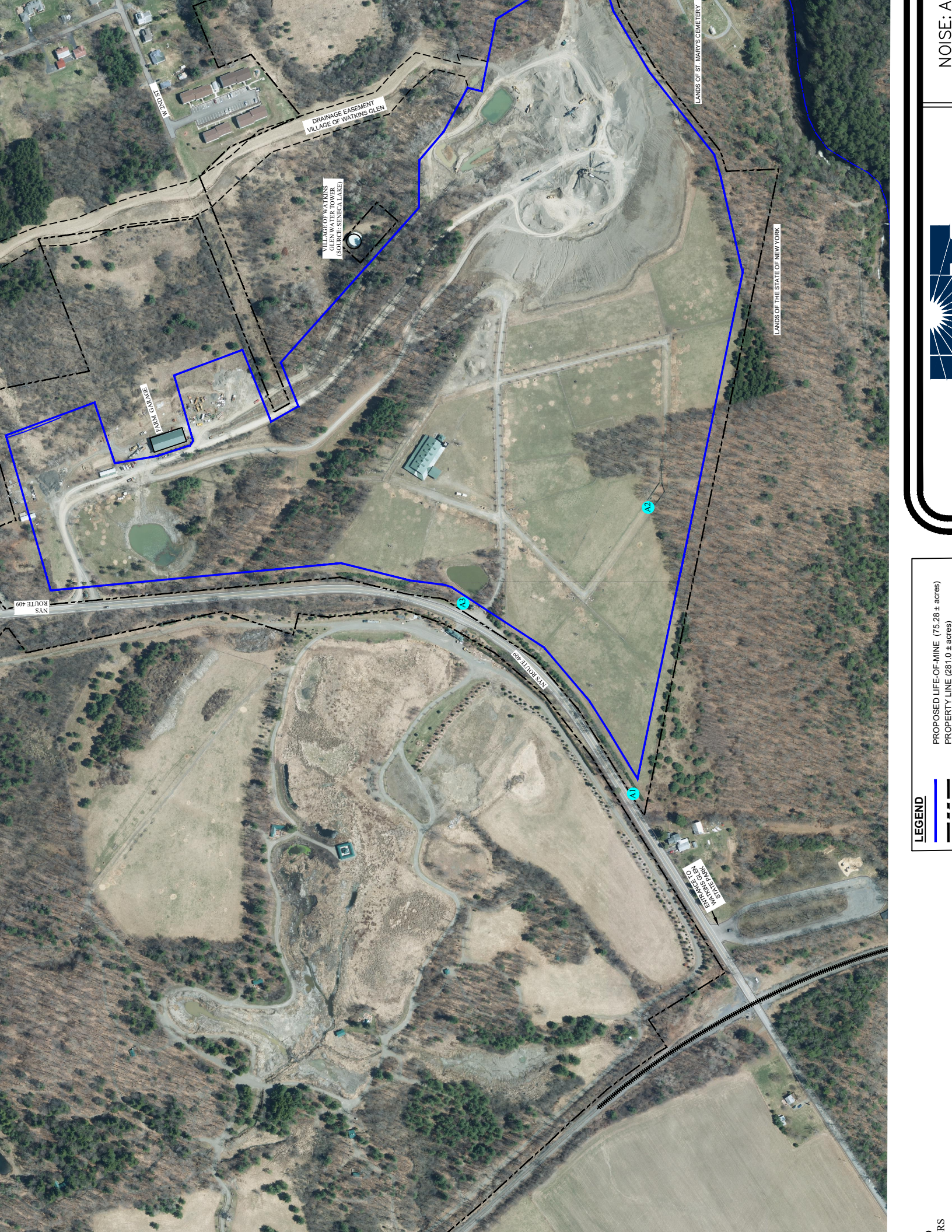

LEGEND

PROPOSED LIFE-OF-MINE (75.28 ± acres)
 PROPERTY LINE (281.0 ± acres)



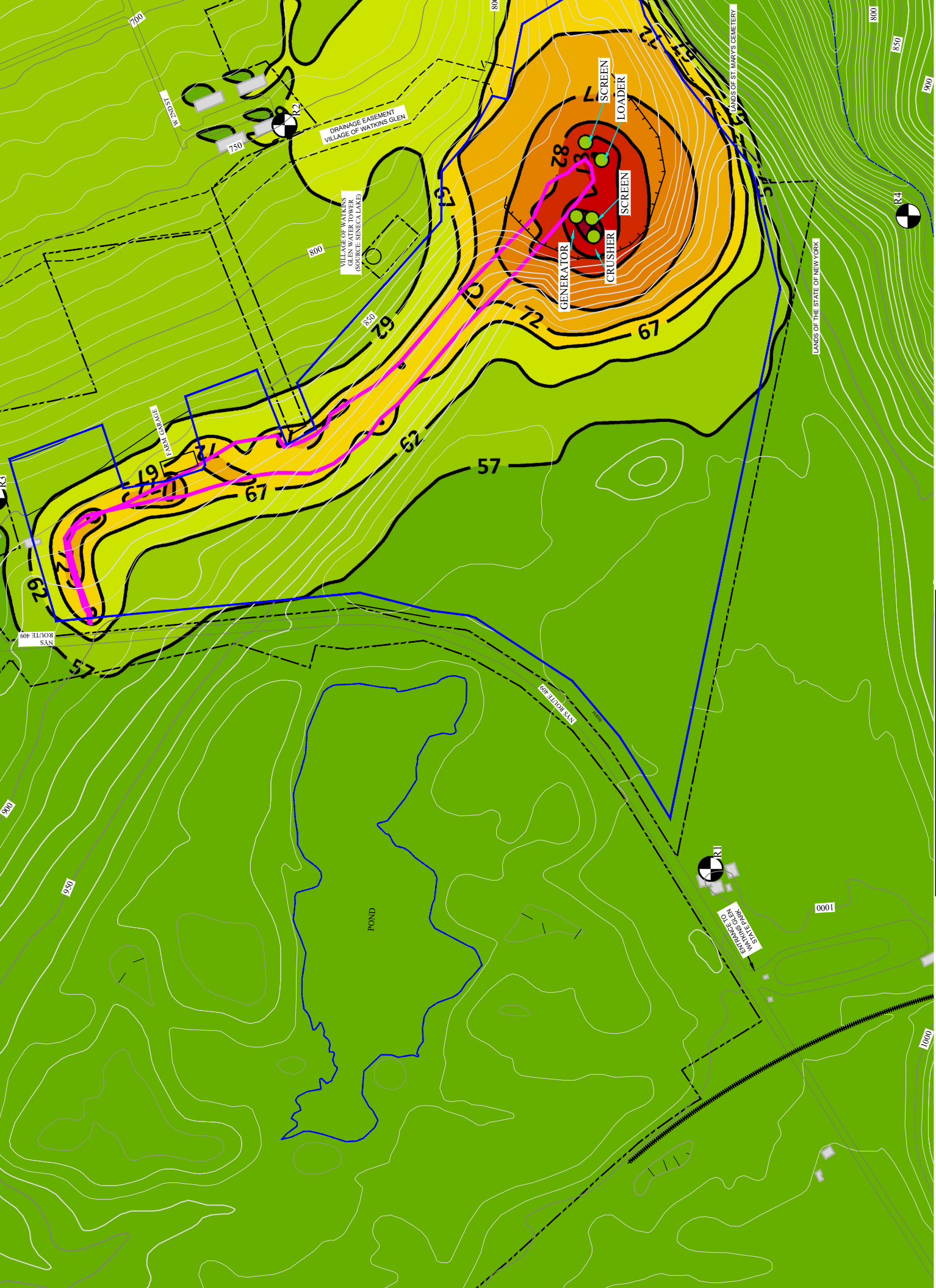

LEGEND

- PROPOSED LIFE-OF-MINE (75.28 ± acres)
- PROPERTY LINE (281.0 ± acres)
- - - - EXISTING MAJOR CONTOUR



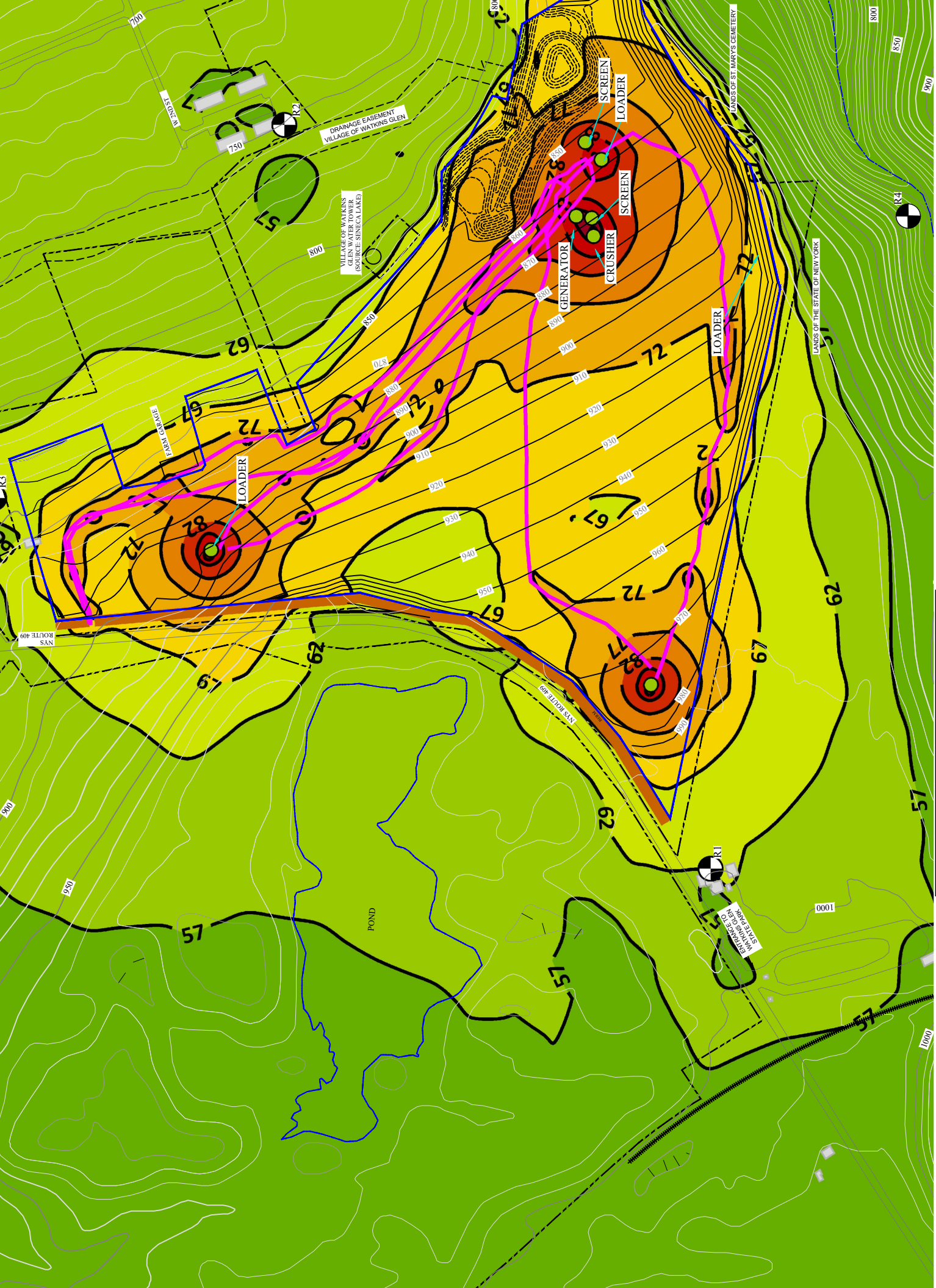

LEGEND

- PROPOSED LIFE-OF-MINE (75.28 ± acres)
- PROPERTY LINE (281.0 ± acres)
- EXISTING MAJOR CONTOUR



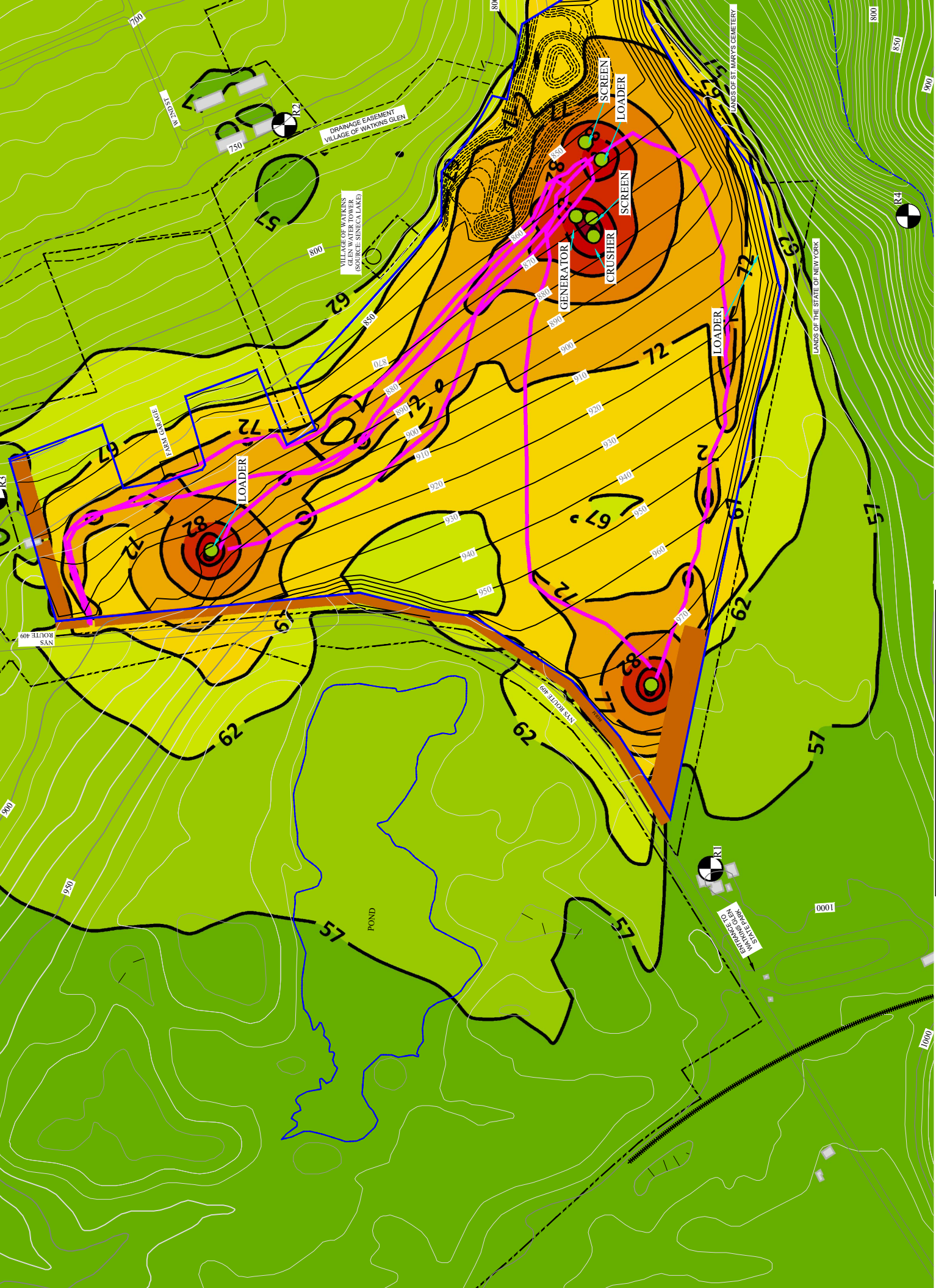

PROPOSED LIFE-OF-MINE (75.28 ± acres)
 PROPERTY LINE (281.0 ± acres)
 EXISTING MAJOR CONTOUR

LEGEND

-  PROPOSED LIFE-OF-MINE (75.28 ± acres)
-  PROPERTY LINE (281.0 ± acres)
-  EXISTING MAJOR CONTOUR



LEGEND

-  PROPOSED LIFE-OF-MINE (75.28 ± acres)
-  PROPERTY LINE (281.0 ± acres)
-  EXISTING MAJOR CONTOUR

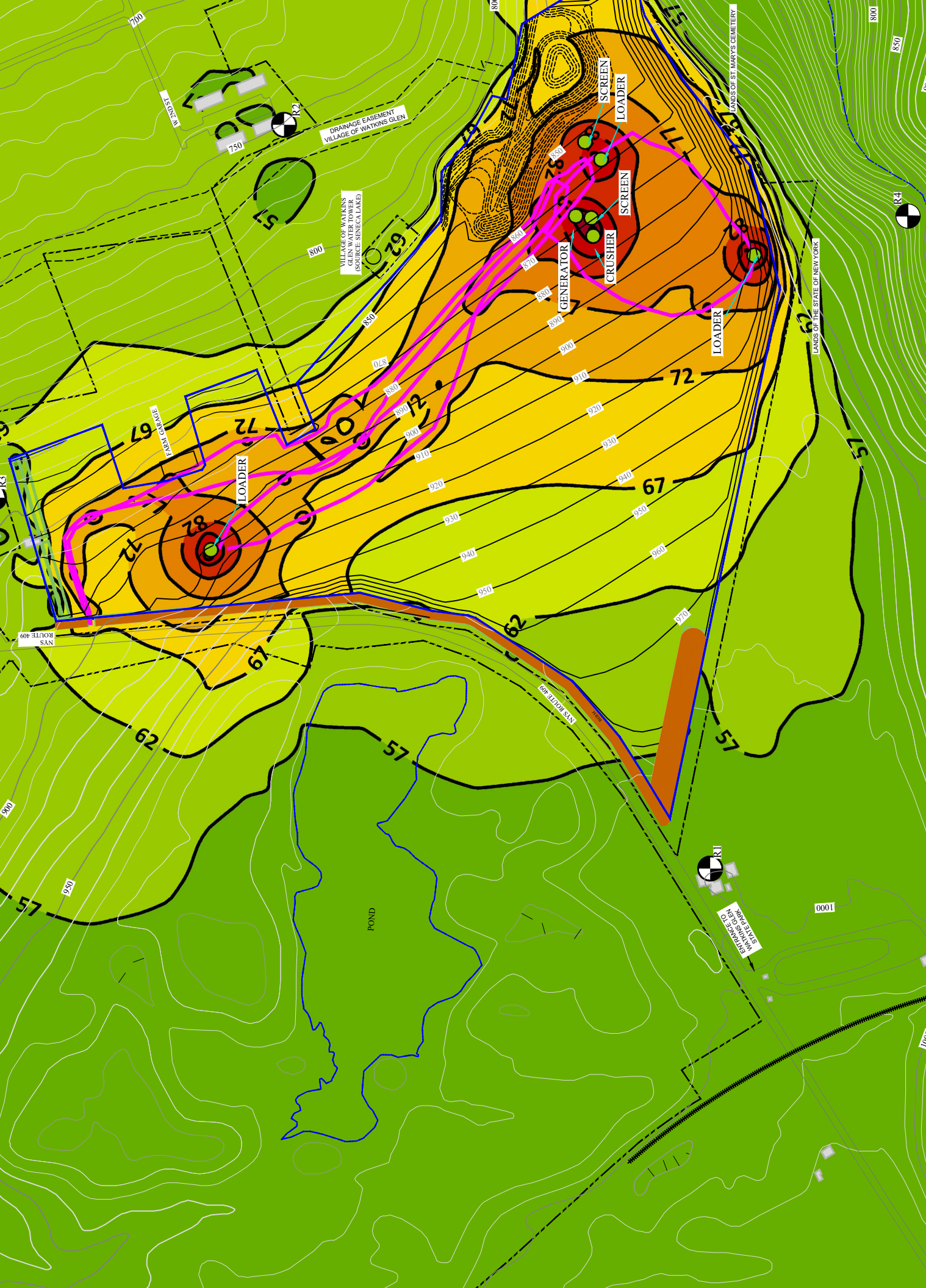

LEGEND

- PROPOSED LIFE-OF-MINE (75.28 ± acres)
- PROPERTY LINE (281.0 ± acres)
- EXISTING MAJOR CONTOUR

NOISE
REFR



APPENDIX A

AMBIENT NOISE MONITORING DATA

Summary								
Filename	831_Data.016							
Serial Number	3221							
Model	Model 831							
Firmware Version	2.313							
User								
Location								
Job Description								
Note								
Measurement Description								
Start	2017/09/08 21:52:35							
Stop	2017/09/08 22:23:04							
Duration	0:30:28.4							
Run Time	0:30:28.4							
Pause	0:00:00.0							
Pre Calibration								
Post Calibration	2016/09/21 15:36:55							
Calibration Deviation	None							
Overall Settings								
RMS Weighting	A Weighting							
Peak Weighting	Z Weighting							
Detector	Slow							
Preamp	PRM831							
Microphone Correction	Off							
Integration Method	Linear							
OBA Range	Normal							
OBA Bandwidth	1/1 and 1/3							
OBA Freq. Weighting	A Weighting							
OBA Max Spectrum	Bin Max							
Gain	0.0 dB							
Overload	144.0 dB							
	A	C	Z					
Under Range Peak	76.4	73.4	78.4	dB				
Under Range Limit	26.3	26.6	32.2	dB				
Noise Floor	17.2	17.5	22.8	dB				
Results								
LAeq	52.3 dB							
LAE	84.9 dB							
EA	34.184 µPa²h							
EAS	538.455 µPa²h							
EA40	2.692 mPa²h							
LZpeak (max)	2017/09/08 22:22:31	96.1 dB						
LASmax	2017/09/08 22:22:31	62.1 dB						
LASmin	2017/09/08 21:52:35	49.7 dB						
SEA	-99.9 dB							
LAS > 45.0 dB (Exceedence Counts / Duration)								
	1	1828.1 s						
LAS > 90.0 dB (Exceedence Counts / Duration)								
	0	0.0 s						
LZpeak > 135.0 dB (Exceedence Counts / Duration)								
	0	0.0 s						
LZpeak > 137.0 dB (Exceedence Counts / Duration)								
	0	0.0 s						
LZpeak > 140.0 dB (Exceedence Counts / Duration)								
	0	0.0 s						
Community Noise								
	Ldn	LDay 07:00-22:00	LNight 22:00-07:00	Lden	LDay 07:00-19:00	LEvening 19:00-22:00	LNight 22:00-07:00	
	58.7		51.9	52.4	-99.9	-99.9	51.9	52.4
LCeq	57.1 dB							
LAeq	52.3 dB							
LCeq - LAeq	4.9 dB							
LAlaq	53.3 dB							
LAeq	52.3 dB							
LAlaq - LAeq	1.0 dB							
# Overloads	0							
Overload Duration	0.0 s							
# OBA Overloads	0							
OBA Overload Duration	0.0 s							
Dose Settings								
Dose Name	OSHA-1		OSHA-2					
Exch. Rate	5		5			dB		
Threshold	90		80			dB		
Criterion Level	90		90			dB		
Criterion Duration	8		8			h		
Results								
Dose	-99.9		-99.9			%		
Projected Dose	-99.9		-99.9			%		
TWA (Projected)	-99.9		-99.9			dB		
TWA (t)	-99.9		-99.9			dB		
Lep (t)	40.3		40.3			dB		
Statistics								
LAS10.00	52.9 dB							
LAS20.00	52.7 dB							
LAS30.00	52.5 dB							
LAS50.00	52.1 dB							
LAS90.00	51.4 dB							
LAS95.00	51.2 dB							
Calibration History								
Preamp	Date							
PRM831	2016/09/21 15:36:55							
Direct	2016/03/08 0:09:46							
PRM831	2017/09/08 12:28:26							
PRM831	2017/09/08 12:27:18							
PRM831	2017/09/01 10:06:30							
PRM831	2017/08/31 10:46:25							
PRM831	2017/08/02 10:36:49							
PRM831	2017/05/11 0:30:42							
PRM831	2017/05/03 13:13:09							
PRM831	2017/05/03 8:47:57							
PRM831	2017/04/28 7:25:37							
PRM831	2017/04/19 21:52:36							
PRM831	2017/04/19 15:30:53							

Summary							
Filename	831_Data.017						
Serial Number	3221						
Model	Model 831						
Firmware Version	2.313						
User							
Location							
Job Description							
Note							
Measurement Description							
Start	2017/09/08 22:31:57						
Stop	2017/09/08 23:03:00						
Duration	0:31:02.7						
Run Time	0:31:02.7						
Pause	0:00:00.0						
Pre Calibration	2016/09/21 15:36:55						
Post Calibration	None						
Calibration Deviation	---						
Overall Settings							
RMS Weighting	A Weighting						
Peak Weighting	Z Weighting						
Detector	Slow						
Preamp	PRM831						
Microphone Correction	Off						
Integration Method	Linear						
OBA Range	Normal						
OBA Bandwidth	1/1 and 1/3						
OBA Freq. Weighting	A Weighting						
OBA Max Spectrum	Bin Max						
Gain	0.0 dB						
Overload	144.0 dB						
	A	C	Z				
Under Range Peak	76.4	73.4	78.4	dB			
Under Range Limit	26.3	26.6	32.2	dB			
Noise Floor	17.2	17.5	22.8	dB			
Results							
LAeq	55.0 dB						
LAE	87.7 dB						
EA	64.790 µPa²h						
EAS	1.002 mPa²h						
EA40	5.009 mPa²h						
LZpeak (max)	2017/09/08 22:44:14	92.2 dB					
LASmax	2017/09/08 22:58:41	76.3 dB					
LASmin	2017/09/08 22:59:41	43.6 dB					
SEA	-99.9 dB						
LAS > 45.0 dB (Exceedence Counts / Duration)	1	1862.4 s					
LAS > 90.0 dB (Exceedence Counts / Duration)	0	0.0 s					
LZpeak > 135.0 dB (Exceedence Counts / Duration)	0	0.0 s					
LZpeak > 137.0 dB (Exceedence Counts / Duration)	0	0.0 s					
LZpeak > 140.0 dB (Exceedence Counts / Duration)	0	0.0 s					
Community Noise							
	Ldn	LDay 07:00-22:00	LNight 22:00-07:00	Lden	LDay 07:00-19:00	LEvening 19:00-22:00	LNight 22:00-07:00
	65.0	-99.9	55.0	65.0	-99.9	-99.9	55.0
LCeq	58.6 dB						
LAeq	55.0 dB						
LCeq - LAeq	3.6 dB						
LALeq	56.8 dB						
LAeq	55.0 dB						
LALeq - LAeq	1.9 dB						
# Overloads	0						
Overload Duration	0.0 s						
# OBA Overloads	0						
OBA Overload Duration	0.0 s						
Dose Settings							
Dose Name	OSHA-1	OSHA-2					
Exch. Rate	5	5 dB					
Threshold	90	80 dB					
Criterion Level	90	90 dB					
Criterion Duration	8	8 h					
Results							
Dose	-99.9	-99.9 %					
Projected Dose	-99.9	-99.9 %					
TWA (Projected)	-99.9	-99.9 dB					
TWA (t)	-99.9	-99.9 dB					
Lep (t)	43.1	43.1 dB					
Statistics							
LAS10.00	49.6 dB						
LAS20.00	46.6 dB						
LAS30.00	46.1 dB						
LAS50.00	45.6 dB						
LAS90.00	44.7 dB						
LAS95.00	44.4 dB						
Calibration History							
Preamp	Date						
PRM831	2016/09/21 15:36:55						
Direct	2016/03/08 0:09:46						
PRM831	2017/09/08 12:28:26						
PRM831	2017/09/08 12:27:18						
PRM831	2017/09/01 10:06:30						
PRM831	2017/08/31 10:46:25						
PRM831	2017/08/02 10:36:49						
PRM831	2017/05/11 0:30:42						
PRM831	2017/05/03 13:13:09						
PRM831	2017/05/03 8:47:57						
PRM831	2017/04/28 7:25:37						
PRM831	2017/04/19 21:52:36						
PRM831	2017/04/19 15:30:53						

Summary							
Filename	831_Data.018						
Serial Number	3221						
Model	Model 831						
Firmware Version	2.313						
User							
Location							
Job Description							
Note							
Measurement Description							
Start	2017/09/08 23:10:24						
Stop	2017/09/08 23:40:28						
Duration	0:30:03.9						
Run Time	0:30:03.9						
Pause	0:00:00.0						
Pre Calibration							
Post Calibration	2016/09/21 15:36:55						
Calibration Deviation	None						
Overall Settings							
RMS Weighting	A Weighting						
Peak Weighting	Z Weighting						
Detector	Slow						
Preamp	PRM831						
Microphone Correction	Off						
Integration Method	Linear						
OBA Range	Normal						
OBA Bandwidth	1/1 and 1/3						
OBA Freq. Weighting	A Weighting						
OBA Max Spectrum	Bin Max						
Gain	0.0 dB						
Overload	144.0 dB						
	A	C	Z				
Under Range Peak	76.4	73.4	78.4	dB			
Under Range Limit	26.3	26.6	32.2	dB			
Noise Floor	17.2	17.5	22.8	dB			
Results							
LAeq	57.9 dB						
LAE	90.5 dB						
EA	123.930 µPa²h						
EAS	1.979 mPa²h						
EA40	9.893 mPa²h						
LZpeak (max)	2017/09/08 23:16:29	100.5 dB					
LASmax	2017/09/08 23:27:57	76.5 dB					
LASmin	2017/09/08 23:28:17	39.9 dB					
SEA	-99.9 dB						
LAS > 45.0 dB (Exceedence Counts / Duration)	18	830.6 s					
LAS > 90.0 dB (Exceedence Counts / Duration)	0	0.0 s					
LZpeak > 135.0 dB (Exceedence Counts / Duration)	0	0.0 s					
LZpeak > 137.0 dB (Exceedence Counts / Duration)	0	0.0 s					
LZpeak > 140.0 dB (Exceedence Counts / Duration)	0	0.0 s					
Community Noise							
	Ldn	LDay 07:00-22:00	LNight 22:00-07:00	Lden	LDay 07:00-19:00	LEvening 19:00-22:00	LNight 22:00-07:00
	67.9	-99.9	57.9	67.9	-99.9	-99.9	57.9
LCeq	67.7 dB						
LAeq	57.9 dB						
LCeq - LAeq	9.8 dB						
LALeq	60.2 dB						
LAeq	57.9 dB						
LALeq - LAeq	2.3 dB						
# Overloads	0						
Overload Duration	0.0 s						
# OBA Overloads	0						
OBA Overload Duration	0.0 s						
Dose Settings							
Dose Name	OSHA-1	OSHA-2					
Exch. Rate	5	5 dB					
Threshold	90	80 dB					
Criterion Level	90	90 dB					
Criterion Duration	8	8 h					
Results							
Dose	-99.9	-99.9 %					
Projected Dose	-99.9	-99.9 %					
TWA (Projected)	-99.9	-99.9 dB					
TWA (t)	-99.9	-99.9 dB					
Lep (t)	45.9	45.9 dB					
Statistics							
LAS10.00	56.1 dB						
LAS20.00	47.6 dB						
LAS30.00	44.9 dB						
LAS50.00	43.5 dB						
LAS90.00	41.6 dB						
LAS95.00	41.4 dB						
Calibration History							
Preamp	Date						
PRM831	2016/09/21 15:36:55						
Direct	2016/03/08 0:09:46						
PRM831	2017/09/08 12:28:26						
PRM831	2017/09/08 12:27:18						
PRM831	2017/09/01 10:06:30						
PRM831	2017/08/31 10:46:25						
PRM831	2017/08/02 10:36:49						
PRM831	2017/05/11 0:30:42						
PRM831	2017/05/03 13:13:09						
PRM831	2017/05/03 8:47:57						
PRM831	2017/04/28 7:25:37						
PRM831	2017/04/19 21:52:36						
PRM831	2017/04/19 15:30:53						



APPENDIX B

NOISE MODEL INPUT DATA

**It's Greener Now, LLC.
Padua Ridge Gravel Pit
Existing Operations**

Model Inputs

Description	Quantity
Haul Truck Routes	1
Loader	1
Generator	1
Crushers	1
Screen Towers	2

SOURCE GEOMETRY

Haul Truck Route-Plant to NYS RTE 409

Vertex	Easting (m)	Northing (m)	Absolute Elevation (m)	Height Above Ground (m)
1	224,927.7955	264,402.4787	274.7777	1.6
2	224,941.2743	264,403.4305	273.6708	1.6
3	224,961.6742	264,410.8004	270.7992	1.6
4	224,980.3740	264,417.5561	268.3163	1.6
5	224,999.2848	264,422.9097	266.4122	1.6
6	225,015.3570	264,425.6855	265.0120	1.6
7	225,027.8397	264,418.9596	264.5590	1.6
8	225,045.8000	264,390.1153	264.8615	1.6
9	225,054.3387	264,367.5775	265.1519	1.6
10	225,070.3630	264,336.4378	265.5216	1.6
11	225,092.0749	264,295.7580	265.9963	1.6
12	225,118.8941	264,252.5385	266.0053	1.6
13	225,126.2816	264,209.7042	267.5898	1.6
14	225,113.8543	264,201.2197	269.6285	1.6
15	225,120.5394	264,181.9063	271.3624	1.6
16	225,127.7072	264,168.8084	272.2828	1.6
17	225,136.0527	264,157.3053	272.6924	1.6
18	225,148.4387	264,153.4978	270.6595	1.6
19	225,166.0089	264,127.7885	273.0245	1.6
20	225,178.5168	264,107.4608	275.5435	1.6
21	225,203.8973	264,080.0910	277.3184	1.6
22	225,239.6763	264,049.5599	278.0223	1.6
23	225,273.7912	264,020.6687	279.3741	1.6
24	225,291.0345	264,003.4158	280.0394	1.6
25	225,313.6632	263,981.7751	278.1140	1.6
26	225,354.0667	263,942.4889	266.7518	1.6
27	225,371.7684	263,934.7556	265.8356	1.6
28	225,389.4702	263,927.0223	265.1814	1.6
29	225,396.6831	263,916.7664	265.5072	1.6
30	225,400.4529	263,907.4103	266.0491	1.6
31	225,408.7741	263,899.2112	266.0872	1.6
32	225,415.1323	263,888.3542	266.5433	1.6
33	225,407.9719	263,882.5519	267.7060	1.6
34	225,393.2549	263,879.8659	269.2366	1.6
35	225,370.8592	263,896.8163	269.6098	1.6
36	225,353.0392	263,911.6198	269.7844	1.6
37	225,327.4177	263,933.4039	270.0145	1.6
38	225,280.2132	263,975.2055	286.8155	1.6
39	225,239.2310	264,015.4480	284.9045	1.6
40	225,160.8589	264,082.0025	283.1907	1.6
41	225,144.5284	264,101.0030	282.5168	1.6
42	225,123.2706	264,116.2685	282.8430	1.6
43	225,097.2723	264,149.7828	280.8614	1.6
44	225,092.0218	264,161.4679	279.7168	1.6
45	225,087.1125	264,174.2024	278.2164	1.6
46	225,087.4161	264,208.6785	273.3320	1.6
47	225,085.4822	264,224.8544	271.3404	1.6
48	225,083.3063	264,236.0040	270.6858	1.6
49	225,072.2619	264,276.2583	268.6831	1.6
50	225,063.0524	264,304.3138	267.6697	1.6
51	225,059.3571	264,332.2006	266.1725	1.6
52	225,055.1044	264,350.5227	265.6776	1.6
53	225,044.3497	264,398.8045	264.6343	1.6
54	225,041.8260	264,408.7671	264.4188	1.6
55	225,033.5708	264,418.2060	264.3301	1.6
56	225,027.0088	264,424.9090	264.3735	1.6
57	225,018.5464	264,430.0445	264.6692	1.6
58	225,004.3422	264,427.9081	265.9395	1.6
59	224,987.0472	264,423.5980	267.5678	1.6
60	224,960.2913	264,414.0200	270.9083	1.6
61	224,947.9667	264,410.3534	272.7158	1.6
62	224,940.2642	264,405.6694	273.6161	1.6
63	224,929.3116	264,404.5645	274.5540	1.6

**It's Greener Now, LLC.
Padua Ridge Gravel Pit
Existing Operations**

Existing Berm-NYS RTE 409*

Vertex	Easting (m)	Northing (m)	Absolute Elevation (m)	Height Above Ground (m)
1	224,936.3507	264,397.4748	272.7910	0.00
2	224,938.9992	264,368.7341	274.4920	0.00
3	224,944.8501	264,305.2413	277.3680	0.00
4	224,947.1598	264,280.8826	280.4161	0.00
5	224,949.0011	264,260.1952	283.4640	0.00
6	224,951.6186	264,231.7911	286.5120	0.00
7	224,953.5126	264,211.2379	289.4738	0.00
8	224,955.1383	264,193.5956	292.6080	0.00
9	224,958.4872	264,157.2545	295.6560	0.00
10	224,959.3513	264,138.6434	298.7040	0.00
11	224,961.6692	264,122.7236	298.7040	0.00
12	224,948.4692	264,069.3478	298.7040	0.00
13	224,943.2042	264,048.0579	297.7560	0.00
14	224,938.9282	264,013.0952	295.6560	0.00
15	224,938.4138	264,008.8896	295.8478	0.00
16	224,935.7145	264,001.5782	296.0046	0.00
17	224,922.8201	263,981.9610	295.6561	0.00
18	224,889.6736	263,931.5329	298.7040	0.00
19	224,870.4890	263,902.3459	299.4673	0.00
20	224,811.3728	263,852.1099	301.2337	0.00
21	224,773.2333	263,828.4682	301.7520	0.00
22	224,726.6869	263,799.6154	301.7520	0.00

*Geometry represents eastern most limit of berm. Berm built towards west of defined line with a 1v2h slope to a height of 2 meters, with a top width of 1 meters.

Point Sources

Description	Easting (m)	Northing (m)	Absolute Elevation (m)	Height Above Ground (m)
Screen Tower	225,433.0893	263,888.2170	266.6331	3.3
Screen Tower	225,353.7900	263,881.5197	272.8866	3.3
Crusher	225,335.0300	263,879.5372	273.8973	3.3
Generator	225,355.7300	263,897.7435	272.4804	3.3
Loader	225,414.7871	263,871.4365	268.1463	1.6

Point Receivers

Description	Easting (m)	Northing (m)	Absolute Elevation (m)	Height Above Ground (m)
Glenn Valley Apartments	225,450.1000	264,201.8072	231.0561	1.6
3320 NYS RTE 409	224,675.7181	263,755.8977	303.3920	1.6
3400 Division St	225,060.4099	264,503.1742	258.8507	1.6
Watkins Glen State Park- Indian Trail Overlook	225355.62	263551.5629	253.3487	1.6

**It's Greener Now, LLC.
Padua Ridge Gravel Pit
Sound Power Levels**

Description	Octave Band Frequency (Hz)											Overall dB(A)	
	8	16	31.5	63	125	250	500	1k	2k	4k	8k		16k
Generator	-	-	110.98	116.18	118.68	115.08	113.48	112.78	111.08	107.98	101.38	92.58	117.9
Primary Crusher	108.88	112.98	117.68	123.18	124.38	121.28	122.18	119.38	117.48	109.38	98.98	85.48	124.4
Screen Tower	93.26	123.46	111.96	108.86	107.96	109.26	109.86	106.86	111.86	100.16	92.66	80.96	115.1
Loader	-	-	114.28	117.28	124.28	121.28	118.28	117.28	116.28	110.28	105.28	98.28	122.6
Haul Truck	-	-	-	109.00	114.00	117.00	112.00	110.00	107.00	91.00	95.00	-	115.06 ¹

¹To model linear source, sound power set to 83 db(A)/m to reflect a sound pressure of 72 db(A) at 15 feet. Octave band weighting maintained.

**It's Greener Now, LLC.
Padua Ridge Gravel Pit
Proposed Operations**

Model Inputs

Description	Quantity
Haul Truck Routes	3
Loaders	3
Generator	1
Crushers	1
Screen Towers	2

SOURCE GEOMETRY

Haul Truck Route-Plant to NYS RTE 409

Vertex	Easting (m)	Northing (m)	Absolute Elevation (m)	Height Above Ground (m)
1	224,927.7955	264,402.4787	274.7777	1.6
2	224,941.2743	264,403.4305	273.6708	1.6
3	224,961.6742	264,410.8004	270.7992	1.6
4	224,980.3740	264,417.5561	268.3163	1.6
5	224,999.2848	264,422.9097	266.4122	1.6
6	225,015.3570	264,425.6855	265.0120	1.6
7	225,027.8397	264,418.9596	264.5590	1.6
8	225,045.8000	264,390.1153	264.8615	1.6
9	225,054.3387	264,367.5775	265.1519	1.6
10	225,070.3630	264,336.4378	265.5216	1.6
11	225,092.0749	264,295.7580	265.9963	1.6
12	225,118.8941	264,252.5385	266.0053	1.6
13	225,126.2816	264,209.7042	267.5898	1.6
14	225,113.8543	264,201.2197	269.6285	1.6
15	225,120.5394	264,181.9063	271.3624	1.6
16	225,127.7072	264,168.8084	272.2828	1.6
17	225,136.0527	264,157.3053	272.6924	1.6
18	225,148.4387	264,153.4978	270.6595	1.6
19	225,166.0089	264,127.7885	273.0245	1.6
20	225,178.5168	264,107.4608	275.5435	1.6
21	225,203.8973	264,080.0910	277.3184	1.6
22	225,239.6763	264,049.5599	278.0223	1.6
23	225,273.7912	264,020.6687	279.3741	1.6
24	225,291.0345	264,003.4158	280.0394	1.6
25	225,313.6632	263,981.7751	278.1140	1.6
26	225,354.0667	263,942.4889	266.7518	1.6
27	225,371.7684	263,934.7556	265.8356	1.6
28	225,389.4702	263,927.0223	265.1814	1.6
29	225,396.6831	263,916.7664	265.5072	1.6
30	225,400.4529	263,907.4103	266.0491	1.6
31	225,408.7741	263,899.2112	266.0872	1.6
32	225,415.1323	263,888.3542	266.5433	1.6
33	225,407.9719	263,882.5519	267.7060	1.6
34	225,393.2549	263,879.8659	269.2366	1.6
35	225,370.8592	263,896.8163	269.6098	1.6
36	225,353.0392	263,911.6198	269.7844	1.6
37	225,327.4177	263,933.4039	270.0145	1.6
38	225,280.2132	263,975.2055	286.8155	1.6
39	225,239.2310	264,015.4480	284.9045	1.6
40	225,160.8589	264,082.0025	283.1907	1.6
41	225,144.5284	264,101.0030	282.5168	1.6
42	225,123.2706	264,116.2685	282.8430	1.6
43	225,097.2723	264,149.7828	280.8614	1.6
44	225,092.0218	264,161.4679	279.7168	1.6
45	225,087.1125	264,174.2024	278.2164	1.6
46	225,087.4161	264,208.6785	273.3320	1.6
47	225,085.4822	264,224.8544	271.3404	1.6
48	225,083.3063	264,236.0040	270.6858	1.6
49	225,072.2619	264,276.2583	268.6831	1.6
50	225,063.0524	264,304.3138	267.6697	1.6
51	225,059.3571	264,332.2006	266.1725	1.6
52	225,055.1044	264,350.5227	265.6776	1.6
53	225,044.3497	264,398.8045	264.6343	1.6
54	225,041.8260	264,408.7671	264.4188	1.6
55	225,033.5708	264,418.2060	264.3301	1.6
56	225,027.0088	264,424.9090	264.3735	1.6
57	225,018.5464	264,430.0445	264.6692	1.6
58	225,004.3422	264,427.9081	265.9395	1.6
59	224,987.0472	264,423.5980	267.5678	1.6
60	224,960.2913	264,414.0200	270.9083	1.6
61	224,947.9667	264,410.3534	272.7158	1.6
62	224,940.2642	264,405.6694	273.6161	1.6
63	224,929.3116	264,404.5645	274.5540	1.6

**It's Greener Now, LLC.
Padua Ridge Gravel Pit
Proposed Operations**

Haul Truck Route-Southwest Loader to Plant and Back

Vertex	Easting (m)	Northing (m)	Absolute Elevation (m)	Height Above Ground (m)
1	224,873.5639	263,813.2671	298.9923	1.6
2	224,892.6687	263,806.2920	298.3212	1.6
3	224,925.4593	263,795.6302	297.4161	1.6
4	224,954.4786	263,782.7599	296.9582	1.6
5	224,986.3036	263,778.5186	295.9954	1.6
6	225,008.1781	263,769.4980	296.0137	1.6
7	225,028.9663	263,767.7003	294.9462	1.6
8	225,050.5994	263,760.2847	293.6957	1.6
9	225,077.9288	263,758.6502	292.9405	1.6
10	225,104.3349	263,757.6975	290.7342	1.6
11	225,139.5756	263,741.6593	290.0528	1.6
12	225,158.2758	263,742.8305	287.6118	1.6
13	225,182.7571	263,738.3054	286.5062	1.6
14	225,212.5724	263,741.9690	283.9705	1.6
15	225,226.9401	263,739.2057	283.1523	1.6
16	225,250.5764	263,740.2985	281.6070	1.6
17	225,290.7043	263,746.3339	278.3869	1.6
18	225,314.0209	263,744.0958	277.0865	1.6
19	225,347.8066	263,754.1016	274.4675	1.6
20	225,379.9872	263,763.8660	271.2361	1.6
21	225,408.3540	263,777.1603	268.0744	1.6
22	225,424.7184	263,799.3186	265.7707	1.6
23	225,431.4522	263,820.0285	264.4391	1.6
24	225,442.5608	263,838.9342	262.9860	1.6
25	225,431.8796	263,855.3834	262.9144	1.6
26	225,415.6165	263,881.6623	262.6701	1.6
27	225,398.1528	263,899.5535	262.4512	1.6
28	225,377.2374	263,918.5670	261.8185	1.6
29	225,356.5699	263,919.5621	264.5296	1.6
30	225,338.7082	263,929.1863	265.3182	1.6
31	225,310.6187	263,924.9616	267.5147	1.6
32	225,295.3277	263,928.4067	268.4588	1.6
33	225,247.8072	263,944.2394	271.3754	1.6
34	225,222.8855	263,946.2361	273.4852	1.6
35	225,186.9270	263,950.6764	276.3727	1.6
36	225,137.8079	263,949.8544	280.4821	1.6
37	225,105.1021	263,949.0389	282.8532	1.6
38	225,059.1932	263,948.6997	286.1486	1.6
39	225,016.6153	263,948.0408	289.0990	1.6
40	224,974.5201	263,944.1717	291.7373	1.6
41	224,959.2780	263,925.4650	293.0640	1.6
42	224,941.6347	263,889.9829	294.7796	1.6
43	224,930.5685	263,865.3385	295.6876	1.6
44	224,917.9331	263,851.1274	296.4163	1.6
45	224,893.7845	263,826.1569	297.8918	1.6
46	224,884.8153	263,818.6229	298.3337	1.6

Haul Truck Route-Northwest Loader to Plant and Back

Vertex	Easting (m)	Northing (m)	Absolute Elevation (m)	Height Above Ground (m)
1	225,007.4826	264,268.5473	277.2607	1.6
2	225,034.2759	264,257.1443	274.3924	1.6
3	225,064.0343	264,221.7521	273.9055	1.6
4	225,084.6392	264,195.9146	273.5966	1.6
5	225,092.1004	264,171.9586	274.2549	1.6
6	225,107.3298	264,143.3836	274.2360	1.6
7	225,117.9964	264,123.7678	274.1415	1.6
8	225,146.0806	264,108.0578	271.7741	1.6
9	225,158.4727	264,098.3470	271.0663	1.6
10	225,185.7388	264,083.8000	269.2290	1.6
11	225,222.6646	264,052.0579	267.6014	1.6
12	225,265.8171	264,017.3941	266.0229	1.6
13	225,280.8522	264,002.9366	265.6524	1.6
14	225,297.2395	263,988.0394	265.1596	1.6
15	225,322.6857	263,964.2162	264.4464	1.6
16	225,340.4584	263,944.3832	264.2340	1.6
17	225,364.2022	263,931.8785	261.4487	1.6
18	225,393.0711	263,919.5017	261.5572	1.6
19	225,385.4359	263,906.1357	262.3069	1.6
20	225,368.3303	263,908.7072	264.2922	1.6
21	225,338.7330	263,934.4782	264.9861	1.6
22	225,318.5396	263,953.3041	265.4149	1.6
23	225,289.8216	263,981.7795	266.1175	1.6
24	225,253.9694	264,002.1085	267.8230	1.6
25	225,207.6498	264,015.0758	271.1940	1.6
26	225,175.8260	264,025.7222	273.6480	1.6
27	225,134.3145	264,045.2000	276.5921	1.6
28	225,101.3789	264,084.6156	278.3319	1.6
29	225,074.5473	264,113.3747	279.7900	1.6
30	225,060.8925	264,135.7562	280.2088	1.6
31	225,031.2800	264,200.1069	279.9141	1.6
32	225,014.9208	264,223.3677	280.5862	1.6
33	225,007.4545	264,260.1836	277.9638	1.6

**It's Greener Now, LLC.
Padua Ridge Gravel Pit
Proposed Operations**

Point Sources

Description	Easting (m)	Northing (m)	Absolute Elevation (m)	Height Above Ground (m)
Screen Tower	225,433.0893	263,888.2170	262.9903	3.3
Screen Tower	225,353.7946	263,881.5197	268.2442	3.3
Crusher	225,335.0341	263,879.5372	269.5766	3.3
Generator	225,355.7348	263,897.7435	267.4192	3.3
Loader	225,414.7900	263,871.4365	263.1988	1.6
Loader (Southwest)	225,414.7900	263,871.4365	263.1988	1.6
Loader (Northwest)	225,414.7900	263,871.4365	263.1988	1.6

Point Receivers

Description	Easting (m)	Northing (m)	Absolute Elevation (m)	Height Above Ground (m)
Glenn Valley Apartments	225,450.1000	264,201.8072	231.0561	1.6
3320 NYS RTE 409	224,675.7181	263,755.8977	303.3920	1.6
3400 Division St	225,060.4099	264,503.1742	258.8507	1.6
Watkins Glen State Park- Indian Trail Overlook	225355.62	263551.5629	253.3487	1.6

Existing Berm-NYS RTE 409*

Vertex	Easting (m)	Northing (m)	Absolute Elevation (m)	Height Above Ground (m)
1	224,936.3507	264,397.4748	272.7910	0.00
2	224,938.9992	264,368.7341	274.4920	0.00
3	224,944.8501	264,305.2413	277.3680	0.00
4	224,947.1598	264,280.8826	280.4161	0.00
5	224,949.0011	264,260.1952	283.4640	0.00
6	224,951.6186	264,231.7911	286.5120	0.00
7	224,953.5126	264,211.2379	289.4738	0.00
8	224,955.1383	264,193.5956	292.6080	0.00
9	224,958.4872	264,157.2545	295.6560	0.00
10	224,959.3513	264,138.6434	298.7040	0.00
11	224,961.6692	264,122.7236	298.7040	0.00
12	224,948.4692	264,069.3478	298.7040	0.00
13	224,943.2042	264,048.0579	297.7560	0.00
14	224,938.9282	264,013.0952	295.6560	0.00
15	224,938.4138	264,008.8896	295.8478	0.00
16	224,935.7145	264,001.5782	296.0046	0.00
17	224,922.8201	263,981.9610	295.6561	0.00
18	224,889.6736	263,931.5329	298.7040	0.00
19	224,870.4890	263,902.3459	299.4673	0.00
20	224,811.3728	263,852.1099	301.2337	0.00
21	224,773.2333	263,828.4682	301.7520	0.00
22	224,726.6869	263,799.6154	301.7520	0.00

*Geometry represents eastern most limit of berm. Berm built towards west of defined line with a 1v:2h slope to a height of 2 meters, with a top width of 1 meters.

**It's Greener Now, LLC.
Padua Ridge Gravel Pit
Mitigated Proposed Operations**

Model Inputs

Description	Quantity
Haul Truck Routes	3
Loaders	3
Generator	1
Crushers	1
Screen Towers	2

SOURCE GEOMETRY

Haul Truck Route-Plant to NYS RTE 409

Vertex	Easting (m)	Northing (m)	Absolute Elevation (m)	Height Above Ground (m)
1	224,927.7955	264,402.4787	274.7777	1.6
2	224,941.2743	264,403.4305	273.6708	1.6
3	224,961.6742	264,410.8004	270.7992	1.6
4	224,980.3740	264,417.5561	268.3163	1.6
5	224,999.2848	264,422.9097	266.4122	1.6
6	225,015.3570	264,425.6855	265.0120	1.6
7	225,027.8397	264,418.9596	264.5590	1.6
8	225,045.8000	264,390.1153	264.8615	1.6
9	225,054.3387	264,367.5775	265.1519	1.6
10	225,070.3630	264,336.4378	265.5216	1.6
11	225,092.0749	264,295.7580	265.9963	1.6
12	225,118.8941	264,252.5385	266.0053	1.6
13	225,126.2816	264,209.7042	267.5898	1.6
14	225,113.8543	264,201.2197	269.6285	1.6
15	225,120.5394	264,181.9063	271.3624	1.6
16	225,127.7072	264,168.8084	272.2828	1.6
17	225,136.0527	264,157.3053	272.6924	1.6
18	225,148.4387	264,153.4978	270.6595	1.6
19	225,166.0089	264,127.7885	273.0245	1.6
20	225,178.5168	264,107.4608	275.5435	1.6
21	225,203.8973	264,080.0910	277.3184	1.6
22	225,239.6763	264,049.5599	278.0223	1.6
23	225,273.7912	264,020.6687	279.3741	1.6
24	225,291.0345	264,003.4158	280.0394	1.6
25	225,313.6632	263,981.7751	278.1140	1.6
26	225,354.0667	263,942.4889	266.7518	1.6
27	225,371.7684	263,934.7556	265.8356	1.6
28	225,389.4702	263,927.0223	265.1814	1.6
29	225,396.6831	263,916.7664	265.5072	1.6
30	225,400.4529	263,907.4103	266.0491	1.6
31	225,408.7741	263,899.2112	266.0872	1.6
32	225,415.1323	263,888.3542	266.5433	1.6
33	225,407.9719	263,882.5519	267.7060	1.6
34	225,393.2549	263,879.8659	269.2366	1.6
35	225,370.8592	263,896.8163	269.6098	1.6
36	225,353.0392	263,911.6198	269.7844	1.6
37	225,327.4177	263,933.4039	270.0145	1.6
38	225,280.2132	263,975.2055	286.8155	1.6
39	225,239.2310	264,015.4480	284.9045	1.6
40	225,160.8589	264,082.0025	283.1907	1.6
41	225,144.5284	264,101.0030	282.5168	1.6
42	225,123.2706	264,116.2685	282.8430	1.6
43	225,097.2723	264,149.7828	280.8614	1.6
44	225,092.0218	264,161.4679	279.7168	1.6
45	225,087.1125	264,174.2024	278.2164	1.6
46	225,087.4161	264,208.6785	273.3320	1.6
47	225,085.4822	264,224.8544	271.3404	1.6
48	225,083.3063	264,236.0040	270.6858	1.6
49	225,072.2619	264,276.2583	268.6831	1.6
50	225,063.0524	264,304.3138	267.6697	1.6
51	225,059.3571	264,332.2006	266.1725	1.6
52	225,055.1044	264,350.5227	265.6776	1.6
53	225,044.3497	264,398.8045	264.6343	1.6
54	225,041.8260	264,408.7671	264.4188	1.6
55	225,033.5708	264,418.2060	264.3301	1.6
56	225,027.0088	264,424.9090	264.3735	1.6
57	225,018.5464	264,430.0445	264.6692	1.6
58	225,004.3422	264,427.9081	265.9395	1.6
59	224,987.0472	264,423.5980	267.5678	1.6
60	224,960.2913	264,414.0200	270.9083	1.6
61	224,947.9667	264,410.3534	272.7158	1.6
62	224,940.2642	264,405.6694	273.6161	1.6
63	224,929.3116	264,404.5645	274.5540	1.6

**It's Greener Now, LLC.
Padua Ridge Gravel Pit
Mitigated Proposed Operations**

Haul Truck Route-Southwest Loader to Plant and Back

Vertex	Easting (m)	Northing (m)	Absolute Elevation (m)	Height Above Ground (m)
1	224,873.5639	263,813.2671	298.9923	1.6
2	224,892.6687	263,806.2920	298.3212	1.6
3	224,925.4593	263,795.6302	297.4161	1.6
4	224,954.4786	263,782.7599	296.9582	1.6
5	224,986.3036	263,778.5186	295.9954	1.6
6	225,008.1781	263,769.4980	296.0137	1.6
7	225,028.9663	263,767.7003	294.9462	1.6
8	225,050.5994	263,760.2847	293.6957	1.6
9	225,077.9288	263,758.6502	292.9405	1.6
10	225,104.3349	263,757.6975	290.7342	1.6
11	225,139.5756	263,741.6593	290.0528	1.6
12	225,158.2758	263,742.8305	287.6118	1.6
13	225,182.7571	263,738.3054	286.5062	1.6
14	225,212.5724	263,741.9690	283.9705	1.6
15	225,226.9401	263,739.2057	283.1523	1.6
16	225,250.5764	263,740.2985	281.6070	1.6
17	225,290.7043	263,746.3339	278.3869	1.6
18	225,314.0209	263,744.0958	277.0865	1.6
19	225,347.8066	263,754.1016	274.4675	1.6
20	225,379.9872	263,763.8660	271.2361	1.6
21	225,408.3540	263,777.1603	268.0744	1.6
22	225,424.7184	263,799.3186	265.7707	1.6
23	225,431.4522	263,820.0285	264.4391	1.6
24	225,442.5608	263,838.9342	262.9860	1.6
25	225,431.8796	263,855.3834	262.9144	1.6
26	225,415.6165	263,881.6623	262.6701	1.6
27	225,398.1528	263,899.5535	262.4512	1.6
28	225,377.2374	263,918.5670	261.8185	1.6
29	225,356.5699	263,919.5621	264.5296	1.6
30	225,338.7082	263,929.1863	265.3182	1.6
31	225,310.6187	263,924.9616	267.5147	1.6
32	225,295.3277	263,928.4067	268.4588	1.6
33	225,247.8072	263,944.2394	271.3754	1.6
34	225,222.8855	263,946.2361	273.4852	1.6
35	225,186.9270	263,950.6764	276.3727	1.6
36	225,137.8079	263,949.8544	280.4821	1.6
37	225,105.1021	263,949.0389	282.8532	1.6
38	225,059.1932	263,948.6997	286.1486	1.6
39	225,016.6153	263,948.0408	289.0990	1.6
40	224,974.5201	263,944.1717	291.7373	1.6
41	224,959.2780	263,925.4650	293.0640	1.6
42	224,941.6347	263,889.9829	294.7796	1.6
43	224,930.5685	263,865.3385	295.6876	1.6
44	224,917.9331	263,851.1274	296.4163	1.6
45	224,893.7845	263,826.1569	297.8918	1.6
46	224,884.8153	263,818.6229	298.3337	1.6

Haul Truck Route-Northwest Loader to Plant and Back

Vertex	Easting (m)	Northing (m)	Absolute Elevation (m)	Height Above Ground (m)
1	225,007.4826	264,268.5473	277.2607	1.6
2	225,034.2759	264,257.1443	274.3924	1.6
3	225,064.0343	264,221.7521	273.9055	1.6
4	225,084.6392	264,195.9146	273.5966	1.6
5	225,092.1004	264,171.9586	274.2549	1.6
6	225,107.3298	264,143.3836	274.2360	1.6
7	225,117.9964	264,123.7678	274.1415	1.6
8	225,146.0806	264,108.0578	271.7741	1.6
9	225,158.4727	264,098.3470	271.0663	1.6
10	225,185.7388	264,083.8000	269.2290	1.6
11	225,222.6646	264,052.0579	267.6014	1.6
12	225,265.8171	264,017.3941	266.0229	1.6
13	225,280.8522	264,002.9366	265.6524	1.6
14	225,297.2395	263,988.0394	265.1596	1.6
15	225,322.6857	263,964.2162	264.4464	1.6
16	225,340.4584	263,944.3832	264.2340	1.6
17	225,364.2022	263,931.8785	261.4487	1.6
18	225,393.0711	263,919.5017	261.5572	1.6
19	225,385.4359	263,906.1357	262.3069	1.6
20	225,368.3303	263,908.7072	264.2922	1.6
21	225,338.7330	263,934.4782	264.9861	1.6
22	225,318.5396	263,953.3041	265.4149	1.6
23	225,289.8216	263,981.7795	266.1175	1.6
24	225,253.9694	264,002.1085	267.8230	1.6
25	225,207.6498	264,015.0758	271.1940	1.6
26	225,175.8260	264,025.7222	273.6480	1.6
27	225,134.3145	264,045.2000	276.5921	1.6
28	225,101.3789	264,084.6156	278.3319	1.6
29	225,074.5473	264,113.3747	279.7900	1.6
30	225,060.8925	264,135.7562	280.2088	1.6
31	225,031.2800	264,200.1069	279.9141	1.6
32	225,014.9208	264,223.3677	280.5862	1.6
33	225,007.4545	264,260.1836	277.9638	1.6

It's Greener Now, LLC.
Padua Ridge Gravel Pit
Mitigated Proposed Operations

Point Sources

Description	Easting (m)	Northing (m)	Absolute Elevation (m)	Height Above Ground (m)
Screen Tower	225,433.0893	263,888.2170	262.9903	3.3
Screen Tower	225,353.7946	263,881.5197	268.2442	3.3
Crusher	225,335.0341	263,879.5372	269.5766	3.3
Generator	225,355.7348	263,897.7435	267.4192	3.3
Loader	225,414.7900	263,871.4365	263.1988	1.6
Loader (Southwest)	225,414.7900	263,871.4365	263.1988	1.6
Loader (Northwest)	225,414.7900	263,871.4365	263.1988	1.6

Point Receivers

Description	Easting (m)	Northing (m)	Absolute Elevation (m)	Height Above Ground (m)
Glenn Valley Apartments	225,450.1000	264,201.8072	231.0561	1.6
3320 NYS RTE 409	224,675.7181	263,755.8977	303.3920	1.6
3400 Division St	225,060.4099	264,503.1742	258.8507	1.6
Watkins Glen State Park- Indian Trail Overlook	225355.62	263551.5629	253.3487	1.6

Existing Berm-NYS RTE 409*

Vertex	Easting (m)	Northing (m)	Absolute Elevation (m)	Height Above Ground (m)
1	224,936.3507	264,397.4748	272.7910	0.00
2	224,938.9992	264,368.7341	274.4920	0.00
3	224,944.8501	264,305.2413	277.3680	0.00
4	224,947.1598	264,280.8826	280.4161	0.00
5	224,949.0011	264,260.1952	283.4640	0.00
6	224,951.6186	264,231.7911	286.5120	0.00
7	224,953.5126	264,211.2379	289.4738	0.00
8	224,955.1383	264,193.5956	292.6080	0.00
9	224,958.4872	264,157.2545	295.6560	0.00
10	224,959.3513	264,138.6434	298.7040	0.00
11	224,961.6692	264,122.7236	298.7040	0.00
12	224,948.4692	264,069.3478	298.7040	0.00
13	224,943.2042	264,048.0579	297.7560	0.00
14	224,938.9282	264,013.0952	295.6560	0.00
15	224,938.4138	264,008.8896	295.8478	0.00
16	224,935.7145	264,001.5782	296.0046	0.00
17	224,922.8201	263,981.9610	295.6561	0.00
18	224,889.6736	263,931.5329	298.7040	0.00
19	224,870.4890	263,902.3459	299.4673	0.00
20	224,811.3728	263,852.1099	301.2337	0.00
21	224,773.2333	263,828.4682	301.7520	0.00
22	224,726.6869	263,799.6154	301.7520	0.00

*Geometry represents eastern most limit of berm. Berm built towards west of defined line with a 1v:2h slope to a height of 2 meters, with a top width of 1 meters.

Proposed Berm-South*

Vertex	Easting (m)	Northing (m)	Absolute Elevation (m)	Height Above Ground (m)
1	224,922.5647	263,760.3341	298.9549	0.00
2	224,911.7186	263,762.9905	298.9019	0.00
3	224,889.0028	263,767.5807	299.5790	0.00
4	224,870.6418	263,771.7001	300.1463	0.00
5	224,855.1056	263,774.7603	301.7520	0.00
6	224,849.1915	263,775.8315	301.7520	0.00
7	224,837.9818	263,777.9981	301.8598	0.00
8	224,824.6997	263,781.0125	302.0349	0.00
9	224,814.7147	263,783.1791	302.1127	0.00
10	224,804.8238	263,784.8746	302.2421	0.00
11	224,786.0782	263,789.1136	302.5356	0.00
12	224,764.6950	263,793.4468	302.6192	0.00
13	224,748.1160	263,797.0263	302.8091	0.00

*Geometry represents southern most limit of berm. Berm built towards north of defined line with a 1v:1.5h slope to a height of 7 meters, with a top width of 2 meters.

Proposed Berm-North*

Vertex	Easting (m)	Northing (m)	Absolute Elevation (m)	Height Above Ground (m)
1	224,933.4800	264,438.4043	270.0270	0.00
2	225,011.0283	264,460.6360	263.4248	0.00
3	225,016.3609	264,462.1123	262.5622	0.00
4	225,023.4098	264,463.9548	262.0970	0.00
5	225,029.1164	264,465.5547	261.5331	0.00
6	225,033.0096	264,466.7280	260.8896	0.00
7	225,039.1428	264,468.4347	260.1223	0.00
8	225,045.7560	264,470.3546	259.3794	0.00
9	225,050.6092	264,471.7413	259.0169	0.00
10	225,056.4758	264,473.3946	258.6548	0.00
11	225,062.2356	264,474.9945	257.8744	0.00
12	225,065.8548	264,476.0661	257.6724	0.00
13	225,071.5756	264,477.7429	257.2050	0.00
14	225077.0992	264479.2718	256.6589157	0.00
15	225081.1433	264480.5047	256.1128009	0.00
16	225087.8505	264482.2802	255.2936516	0.00
17	225093.6206	264483.9076	254.5043521	0.00
18	225096.7277	264484.9433	253.8308025	0.00
19	225099.6374	264485.7324	253.2443404	0.00
20	225100.4758	264486.0283	252.7903641	0.00
21	225100.7717	264486.1269	252.7340207	0.00

It's Greener Now, LLC.
Padua Ridge Gravel Pit
Mitigated Proposed Operations

*Geometry represents northern most limit of berm. Berm built towards south of defined line with a 1v:1.5h slope to a height of 4.5 meters, with a top width of 1 meters.

**It's Greener Now, LLC.
Padua Ridge Gravel Pit
Mitigated Proposed Operations**

Model Inputs

Description	Quantity
Haul Truck Routes	3
Loaders	3
Generator	1
Crushers	1
Screen Towers	2

SOURCE GEOMETRY

Haul Truck Route-Plant to NYS RTE 409

Vertex	Easting (m)	Northing (m)	Absolute Elevation (m)	Height Above Ground (m)
1	224,927.7955	264,402.4787	274.7777	1.6
2	224,941.2743	264,403.4305	273.6708	1.6
3	224,961.6742	264,410.8004	270.7992	1.6
4	224,980.3740	264,417.5561	268.3163	1.6
5	224,999.2848	264,422.9097	266.4122	1.6
6	225,015.3570	264,425.6855	265.0120	1.6
7	225,027.8397	264,418.9596	264.5590	1.6
8	225,045.8000	264,390.1153	264.8615	1.6
9	225,054.3387	264,367.5775	265.1519	1.6
10	225,070.3630	264,336.4378	265.5216	1.6
11	225,092.0749	264,295.7580	265.9963	1.6
12	225,118.8941	264,252.5385	266.0053	1.6
13	225,126.2816	264,209.7042	267.5898	1.6
14	225,113.8543	264,201.2197	269.6285	1.6
15	225,120.5394	264,181.9063	271.3624	1.6
16	225,127.7072	264,168.8084	272.2828	1.6
17	225,136.0527	264,157.3053	272.6924	1.6
18	225,148.4387	264,153.4978	270.6595	1.6
19	225,166.0089	264,127.7885	273.0245	1.6
20	225,178.5168	264,107.4608	275.5435	1.6
21	225,203.8973	264,080.0910	277.3184	1.6
22	225,239.6763	264,049.5599	278.0223	1.6
23	225,273.7912	264,020.6687	279.3741	1.6
24	225,291.0345	264,003.4158	280.0394	1.6
25	225,313.6632	263,981.7751	278.1140	1.6
26	225,354.0667	263,942.4889	266.7518	1.6
27	225,371.7684	263,934.7556	265.8356	1.6
28	225,389.4702	263,927.0223	265.1814	1.6
29	225,396.6831	263,916.7664	265.5072	1.6
30	225,400.4529	263,907.4103	266.0491	1.6
31	225,408.7741	263,899.2112	266.0872	1.6
32	225,415.1323	263,888.3542	266.5433	1.6
33	225,407.9719	263,882.5519	267.7060	1.6
34	225,393.2549	263,879.8659	269.2366	1.6
35	225,370.8592	263,896.8163	269.6098	1.6
36	225,353.0392	263,911.6198	269.7844	1.6
37	225,327.4177	263,933.4039	270.0145	1.6
38	225,280.2132	263,975.2055	286.8155	1.6
39	225,239.2310	264,015.4480	284.9045	1.6
40	225,160.8589	264,082.0025	283.1907	1.6
41	225,144.5284	264,101.0030	282.5168	1.6
42	225,123.2706	264,116.2685	282.8430	1.6
43	225,097.2723	264,149.7828	280.8614	1.6
44	225,092.0218	264,161.4679	279.7168	1.6
45	225,087.1125	264,174.2024	278.2164	1.6
46	225,087.4161	264,208.6785	273.3320	1.6
47	225,085.4822	264,224.8544	271.3404	1.6
48	225,083.3063	264,236.0040	270.6858	1.6
49	225,072.2619	264,276.2583	268.6831	1.6
50	225,063.0524	264,304.3138	267.6697	1.6
51	225,059.3571	264,332.2006	266.1725	1.6
52	225,055.1044	264,350.5227	265.6776	1.6
53	225,044.3497	264,398.8045	264.6343	1.6
54	225,041.8260	264,408.7671	264.4188	1.6
55	225,033.5708	264,418.2060	264.3301	1.6
56	225,027.0088	264,424.9090	264.3735	1.6
57	225,018.5464	264,430.0445	264.6692	1.6
58	225,004.3422	264,427.9081	265.9395	1.6
59	224,987.0472	264,423.5980	267.5678	1.6
60	224,960.2913	264,414.0200	270.9083	1.6
61	224,947.9667	264,410.3534	272.7158	1.6
62	224,940.2642	264,405.6694	273.6161	1.6
63	224,929.3116	264,404.5645	274.5540	1.6

**It's Greener Now, LLC.
Padua Ridge Gravel Pit
Mitigated Proposed Operations**

Haul Truck Route-Southwest Loader to Plant and Back

Vertex	Easting (m)	Northing (m)	Absolute Elevation (m)	Height Above Ground (m)
1	224,873.5639	263,813.2671	298.9923	1.6
2	224,892.6687	263,806.2920	298.3212	1.6
3	224,925.4593	263,795.6302	297.4161	1.6
4	224,954.4786	263,782.7599	296.9582	1.6
5	224,986.3036	263,778.5186	295.9954	1.6
6	225,008.1781	263,769.4980	296.0137	1.6
7	225,028.9663	263,767.7003	294.9462	1.6
8	225,050.5994	263,760.2847	293.6957	1.6
9	225,077.9288	263,758.6502	292.9405	1.6
10	225,104.3349	263,757.6975	290.7342	1.6
11	225,139.5756	263,741.6593	290.0528	1.6
12	225,158.2758	263,742.8305	287.6118	1.6
13	225,182.7571	263,738.3054	286.5062	1.6
14	225,212.5724	263,741.9690	283.9705	1.6
15	225,226.9401	263,739.2057	283.1523	1.6
16	225,250.5764	263,740.2985	281.6070	1.6
17	225,290.7043	263,746.3339	278.3869	1.6
18	225,314.0209	263,744.0958	277.0865	1.6
19	225,347.8066	263,754.1016	274.4675	1.6
20	225,379.9872	263,763.8660	271.2361	1.6
21	225,408.3540	263,777.1603	268.0744	1.6
22	225,424.7184	263,799.3186	265.7707	1.6
23	225,431.4522	263,820.0285	264.4391	1.6
24	225,442.5608	263,838.9342	262.9860	1.6
25	225,431.8796	263,855.3834	262.9144	1.6
26	225,415.6165	263,881.6623	262.6701	1.6
27	225,398.1528	263,899.5535	262.4512	1.6
28	225,377.2374	263,918.5670	261.8185	1.6
29	225,356.5699	263,919.5621	264.5296	1.6
30	225,338.7082	263,929.1863	265.3182	1.6
31	225,310.6187	263,924.9616	267.5147	1.6
32	225,295.3277	263,928.4067	268.4588	1.6
33	225,247.8072	263,944.2394	271.3754	1.6
34	225,222.8855	263,946.2361	273.4852	1.6
35	225,186.9270	263,950.6764	276.3727	1.6
36	225,137.8079	263,949.8544	280.4821	1.6
37	225,105.1021	263,949.0389	282.8532	1.6
38	225,059.1932	263,948.6997	286.1486	1.6
39	225,016.6153	263,948.0408	289.0990	1.6
40	224,974.5201	263,944.1717	291.7373	1.6
41	224,959.2780	263,925.4650	293.0640	1.6
42	224,941.6347	263,889.9829	294.7796	1.6
43	224,930.5685	263,865.3385	295.6876	1.6
44	224,917.9331	263,851.1274	296.4163	1.6
45	224,893.7845	263,826.1569	297.8918	1.6
46	224,884.8153	263,818.6229	298.3337	1.6

Haul Truck Route-South Loader to Plant and Back

Vertex	Easting (m)	Northing (m)	Absolute Elevation (m)	Height Above Ground (m)
1	225,320.7215	263,713.9330	282.4638	1.6
2	225,333.0939	263,721.4725	280.1329	1.6
3	225,353.9978	263,739.2258	275.4334	1.6
4	225,384.0813	263,757.8726	271.5193	1.6
5	225,408.3540	263,777.1603	268.1044	1.6
6	225,424.7184	263,799.3186	265.8007	1.6
7	225,431.4522	263,820.0285	264.4691	1.6
8	225,442.5608	263,838.9342	263.0160	1.6
9	225,431.8796	263,855.3834	262.9444	1.6
10	225,415.6165	263,881.6623	262.7001	1.6
11	225,398.1528	263,899.5535	262.4812	1.6
12	225,377.2374	263,918.5670	261.8485	1.6
13	225,356.5699	263,919.5621	264.5596	1.6
14	225,338.7082	263,929.1863	265.3482	1.6
15	225,319.7396	263,905.6380	267.8054	1.6
16	225,293.0093	263,887.6360	270.6133	1.6
17	225,268.4610	263,848.9042	274.6892	1.6
18	225,259.1872	263,823.8105	276.8190	1.6
19	225,252.0955	263,797.6300	278.5588	1.6
20	225,256.4596	263,765.9856	279.7220	1.6
21	225,262.3424	263,755.7681	279.8044	1.6
22	225,279.6413	263,730.2685	280.9158	1.6
23	225,293.7536	263,716.3495	282.9638	1.6
24	225,310.5723	263,712.0965	283.0802	1.6

It's Greener Now, LLC.
Padua Ridge Gravel Pit
Mitigated Proposed Operations

Point Sources

Description	Easting (m)	Northing (m)	Absolute Elevation (m)	Height Above Ground (m)
Screen Tower	225,433.0893	263,888.2170	262.9903	3.3
Screen Tower	225,353.7946	263,881.5197	268.2442	3.3
Crusher	225,335.0341	263,879.5372	269.5766	3.3
Generator	225,355.7348	263,897.7435	267.4192	3.3
Loader	225,414.7900	263,871.4365	263.1988	1.6
Loader (Southwest)	225,414.7900	263,871.4365	263.1988	1.6
Loader (South)	225,315.2500	263,711.7201	283.0609	1.6

Point Recievers

Description	Easting (m)	Northing (m)	Absolute Elevation (m)	Height Above Ground (m)
Glenn Valley Apartments	225,450.1000	264,201.8072	231.0561	1.6
3320 NYS RTE 409	224,675.7181	263,755.8977	303.3920	1.6
3400 Division St	225,060.4099	264,503.1742	258.8507	1.6
Watkins Glen State Park- Indian Trail Overlook	225355.62	263551.5629	253.3487	1.6

Existing Berm-NYS RTE 409*

Vertex	Easting (m)	Northing (m)	Absolute Elevation (m)	Height Above Ground (m)
1	224,936.3507	264,397.4748	272.7910	0.00
2	224,938.9992	264,368.7341	274.4920	0.00
3	224,944.8501	264,305.2413	277.3680	0.00
4	224,947.1598	264,280.8826	280.4161	0.00
5	224,949.0011	264,260.1952	283.4640	0.00
6	224,951.6186	264,231.7911	286.5120	0.00
7	224,953.5126	264,211.2379	289.4738	0.00
8	224,955.1383	264,193.5956	292.6080	0.00
9	224,958.4872	264,157.2545	295.6560	0.00
10	224,959.3513	264,138.6434	298.7040	0.00
11	224,961.6692	264,122.7236	298.7040	0.00
12	224,948.4692	264,069.3478	298.7040	0.00
13	224,943.2042	264,048.0579	297.7560	0.00
14	224,938.9282	264,013.0952	295.6560	0.00
15	224,938.4138	264,008.8896	295.8478	0.00
16	224,935.7145	264,001.5782	296.0046	0.00
17	224,922.8201	263,981.9610	295.6561	0.00
18	224,889.6736	263,931.5329	298.7040	0.00
19	224,870.4890	263,902.3459	299.4673	0.00
20	224,811.3728	263,852.1099	301.2337	0.00
21	224,773.2333	263,828.4682	301.7520	0.00
22	224,726.6869	263,799.6154	301.7520	0.00

*Geometry represents eastern most limit of berm. Berm built towards west of defined line with a 1v:2h slope to a height of 2 meters, with a top width of 1 meters.

Proposed Berm-South*

Vertex	Easting (m)	Northing (m)	Absolute Elevation (m)	Height Above Ground (m)
1	224,922.5647	263,760.3341	298.9549	0.00
2	224,911.7186	263,762.9905	298.9019	0.00
3	224,889.0028	263,767.5807	299.5790	0.00
4	224,870.6418	263,771.7001	300.1463	0.00
5	224,855.1056	263,774.7603	301.7520	0.00
6	224,849.1915	263,775.8315	301.7520	0.00
7	224,837.9818	263,777.9981	301.8598	0.00
8	224,824.6997	263,781.0125	302.0349	0.00
9	224,814.7147	263,783.1791	302.1127	0.00
10	224,804.8238	263,784.8746	302.2421	0.00
11	224,786.0782	263,789.1136	302.5356	0.00
12	224,764.6950	263,793.4468	302.6192	0.00
13	224,748.1160	263,797.0263	302.8091	0.00

*Geometry represents southern most limit of berm. Berm built towards north of defined line with a 1v:1.5h slope to a height of 7 meters, with a top width of 2 meters.

Proposed Berm-North*

Vertex	Easting (m)	Northing (m)	Absolute Elevation (m)	Height Above Ground (m)
1	224,933.4800	264,438.4043	270.0270	0.00
2	225,011.0283	264,460.6360	263.4248	0.00
3	225,016.3609	264,462.1123	262.5622	0.00
4	225,023.4098	264,463.9548	262.0970	0.00
5	225,029.1164	264,465.5547	261.5331	0.00
6	225,033.0096	264,466.7280	260.8896	0.00
7	225,039.1428	264,468.4347	260.1223	0.00
8	225,045.7560	264,470.3546	259.3794	0.00
9	225,050.6092	264,471.7413	259.0169	0.00
10	225,056.4758	264,473.3946	258.6548	0.00
11	225,062.2356	264,474.9945	257.8744	0.00
12	225,065.8548	264,476.0661	257.6724	0.00
13	225,071.5756	264,477.7429	257.2050	0.00
14	225077.0992	264479.2718	256.6589157	0.00
15	225081.1433	264480.5047	256.1128009	0.00
16	225087.8505	264482.2802	255.2936516	0.00
17	225093.6206	264483.9076	254.5043521	0.00
18	225096.7277	264484.9433	253.8308025	0.00
19	225099.6374	264485.7324	253.2443404	0.00
20	225100.4758	264486.0283	252.7903641	0.00
21	225100.7717	264486.1269	252.7340207	0.00

It's Greener Now, LLC.
Padua Ridge Gravel Pit
Mitigated Proposed Operations

*Geometry represents northern most limit of berm. Berm built towards south of defined line with a 1v:1.5h slope to a height of 4.5 meters, with a top width of 1 meters.



APPENDIX E

GROUNDWATER MONITORING WELL DATA (ON CD)



APPENDIX F

MINED LAND USE PLAN



MODIFICATION APPLICATION FOR PERMIT TO MINE AND MINED LAND USE PLAN

**IT'S GREENER NOW, INC.
PADUA RIDGE GRAVEL MINE
DIX, NEW YORK**

**NEW YORK STATE
DEPARTMENT OF ENVIRONMENTAL CONSERVATION
MLF # 80244**

Prepared for:
It's Greener Now, Inc.
3362 NYS Route 409
Watkins Glen, New York 14891

Prepared by:
JMT of New York, Inc.
19 British American Boulevard
Latham, New York 12110

Submitted: July 2022

Project No: 16-S0157N-001

A decorative graphic in the bottom right corner of the page, consisting of several overlapping, diagonal, triangular shapes in shades of gray and blue, pointing towards the top right.



TABLE OF CONTENTS

1.0	INTRODUCTION.....	1
2.0	MINE PLAN.....	2
2.1	SITE LOCATION AND HISTORY.....	2
2.2	ENVIRONMENTAL SETTING.....	2
2.2.1	Adjacent Land Use Features.....	2
2.2.2	Man-made Features.....	2
2.2.3	Topography and Geology.....	3
2.2.4	Wetlands and Water Resources.....	3
2.2.5	Vegetation.....	4
2.2.6	Wildlife.....	4
2.2.7	Cultural Resources.....	4
2.3	DESCRIPTION OF MINING METHOD.....	4
2.3.1	Mining Method.....	5
2.3.1.1	<i>Excavation Equipment.....</i>	5
2.3.1.2	<i>Mining Sequence.....</i>	5
2.3.1.3	<i>Grading and Setbacks.....</i>	6
2.3.1.4	<i>Roadways.....</i>	6
2.3.1.5	<i>Disposal of Waste Materials.....</i>	7
2.3.1.6	<i>Traffic.....</i>	7
2.3.1.7	<i>Hours of Operation.....</i>	7
2.3.1.8	<i>Site Facilities.....</i>	8
2.4	ASSESSMENT AND MITIGATION OF POTENTIAL ENVIRONMENTAL IMPACTS.....	8
2.4.1	Potential Impacts to Air Resources.....	8
2.4.2	Potential Impacts to Vegetation and Wildlife.....	9
2.4.3	Potential Impacts to Water Resources.....	9
2.4.4	Potential Noise Impacts.....	10
2.4.5	Potential Drainage and Erosion Impacts.....	11



MODIFICATION APPLICATION FOR PERMIT TO MLUP
It's Greener Now, Inc.- Padua Ridge Gravel Mine

2.4.6 Potential Visual Impacts.....11
2.4.7 Potential Traffic Impacts12
3.0 RECLAMATION PLAN.....13
3.1 RECLAMATION SCHEDULE.....13
3.2 SEQUENTIAL RECLAMATION PLANS.....13
3.3 HAUL ROADS13
3.4 DISPOSITION OF MATERIAL14
3.5 REVEGETATION14

FIGURE

FIGURE 1 SITE LOCATION

SHEETS

SHEET 1 MINE PLAN MAP

SHEET 2 RECLAMATION PLAN

SHEET 3 FINAL GRADE PROFILES

APPENDIX

APPENDIX A MINING PERMIT APPLICATION
ORGANIZATIONAL REPORT FORM



1.0 INTRODUCTION

This document constitutes a modification application for Mined Land Reclamation Permit (8-4424-00006/00001) and an updated Mined Land Use Plan (MLUP) for the It's Greener Now, Inc. (IGN) Padua Ridge Gravel Mine, (MLF # 80244), located in the Town of Dix, Schuyler County, New York. This MLUP summarizes mining and reclamation plans for the continued operation of the Padua Ridge Gravel Mine. This application and MLUP includes additional mining area within the property controlled by IGN that has not been previously approved. Included herewith is a Modification Application for Permit to Mine, an updated Organizational Report Form, and updated Mine and Reclamation Plan Maps and Final Grade Profiles, which illustrate the mining limits as proposed in this application. Additional materials are also included in an associated Draft Environmental Impact Statement (DEIS).

The information presented in this document is submitted in compliance with the application requirements contained in Article 23, Title 27, of the New York State Environmental Conservation Law and known as the Mined Land Reclamation Law (MLRL).

Mining is not prohibited at this site. The site is an active sand and gravel mine.



2.0 MINE PLAN

2.1 SITE LOCATION AND HISTORY

This report is an updated MLUP for the IGN Padua Ridge Gravel Mine (MLF # 80244) located in the Town of Dix, Schuyler County, New York. The mine site is located along New York State Route 409 and occupies a portion of the approximately 281-acre parcel owned by IGN.

IGN is submitting this modification application to extend mining operations to the west and north onto additional land owned/controlled by IGN.

This application proposes to add 60.95 +/- acres to the currently approved 14.33 acre Affected Area boundary, which totals a 75.28 +/- Life of Mine affected area for the site. Figure 1, "Site Location Map", illustrates the location of the mine site and its relationship to the surrounding area. The mine site is bound by NYS Route 409 on the west, the lands of Watkins Glen State Park on the south west, and the lands of St. Mary's Cemetery to the south east.

Mining at this site began in the 1970s. Operations at the site currently entail the extraction of sand and gravel in the central and eastern portions of the mine site parcel. The extracted sand and gravel is then processed onsite for sale as aggregate and other similar products.

2.2 ENVIRONMENTAL SETTING

2.2.1 Adjacent Land Use Features

The land use in the vicinity of the Padua Ridge Gravel Mine has not changed significantly since the inception of the mining operation. The perimeter land uses are agricultural, woodlands, rural residential and parkland. A few residences are located along West 2nd Street to the east of the mine site and along NYS Rte 490 to the west, and Division Street to the north. St. Marys Cemetery and Watkins Glen State Park are located to the south of the mine site. The IGN property includes additional lands to the west and north (across NYS Rte 409).

2.2.2 Man-made Features

The Padua Ridge Gravel mine is an active sand and gravel pit. Man-made features on the site include all equipment and structures for the administration and production of aggregate. Other



features include disturbed areas created during previous mining activity such as internal access roads, stripping areas, processed material, overburden storage piles, screening berms, and stormwater management ponds. A majority of the property is currently subject to agricultural activities. There is a barn present within the proposed expansion area, and a garage on the property outside the proposed expansion area that are both currently utilized for on-site agricultural (livestock) operations.

2.2.3 Topography and Geology

The topography of the Padua Ridge Gravel Mine is generally flat to the southwest, while areas to the east and northeast slope down towards the northeast. Elevations in the currently approved affected area range from 830 ft amsl near the stormwater management ponds to 950 ft amsl along the crest of currently approved mining operations. The topography in the new expansion area ranges from 830 ft amsl east of the scale house to 990 ft amsl along the southwestern border of the proposed expansion area. The current affected area is in the southeastern portion of the mine site property.

The mine site is located within the deltaic deposit associated with deposition by the Watkins Glen Creek into pro-glacial Lake Newberry. Soils at the site are dominated by Howard Soils, Valois Gravelly Silt Loam, and Howard Gravelly Loam.

2.2.4 Wetlands and Water Resources

There are several settling ponds within the existing mine site. The ponds are located in the northeast portion of the current affected area. Drainage from the plant area is directed into these ponds where the water is allowed to evaporate and/or infiltrate the highly permeable sand and gravel. Water from the settling ponds is used as process water and dust suppression. There are two man-made ponds within the proposed expansion area that are currently utilized in support of on-site livestock operations. An expanded stormwater management area will be established to accommodate stormwater demand from expanded mining operations.

Via observation of a series of wells and springs on the site, groundwater is identified at depths ranging from at- or near-surface to 80 feet below existing ground surface. The mine floor will be maintained at least five (5) feet above the seasonal high-water table. No below-water-table



operations are proposed as part of this application. A more detailed discussion of water resources can be found in the attached DEIS.

2.2.5 Vegetation

Vegetation within the existing mine site and proposed expansion area is variable. In the active mining area, vegetation has been removed. West of the currently approved affected area, vegetation is dominated by pastureland. To the south and east, vegetation is predominantly deciduous forest upland. The proposed expansion area is mostly pasturelands with some areas of deciduous upland forest.

2.2.6 Wildlife

The mine site, including the proposed expansion area, may be habitat for common small animals such as squirrels, rabbits, woodchucks and other rodent species. Much of the proposed-expansion area is perimeter-fenced pastureland, limiting the occurrence of larger game animals.

The NY Natural Heritage Program (NYNHP) acknowledged the potential for occurrence of one special concern animal species: Gray Petaltail, *Tachopteryx thoreyi* and also identified three (3) significant natural communities: Calcareous Shoreline Outcrop, Hemlock-Northern Hardwood Forest, and Shale Cliff and Talus Community within Watkins Glen State Park. A detailed discussion of vegetation and wildlife can be found in the DEIS.

2.2.7 Cultural Resources

There are no identified cultural or historical resources at the mine site. However, the adjacent Watkins Glen State Park is eligible for listing in both the National and State Registries of Historic Places, and the Watkins Glen Grand Prix Road Course is listed on the National Register of Historic Places. It is not anticipated the expansion will adversely impact the eligibility of the Park or have the potential to impact the Park's cultural characteristics which qualify it for eligibility, nor will it impact the Road Course. Please see the attached DEIS for a more detailed description of Cultural Resources.



2.3 DESCRIPTION OF MINING METHOD

2.3.1 Mining Method

The method of material extraction within the expansion area will be consistent with the previously reviewed and approved Mined Land Use Plan for the mine site. Sand and gravel will continue to be excavated by front-end loader and and/or excavator, and loaded onto haul trucks for sale or transported to the onsite processing plant for production of saleable aggregate. Expansion into the proposed affected area will be accomplished in a similar manner.

2.3.1.1 Excavation Equipment

Consistent with current excavation activity at the Padua Ridge Gravel Mine, standard industry equipment will be used to strip, excavate, and haul materials from bank faces. Bulldozers, scrapers, front-end wheel loaders, haul trucks and other standard industry equipment will be used as needed to accomplish each task.

2.3.1.2 Mining Sequence

The Mine Plan Map (Sheet 1) illustrates the limits of the proposed affected area within which mining will take place over the duration of mining operations.

IGN will continue to excavate within the currently affected area, dependent on market demand. Mining will also progress to the west and north, into the proposed expansion as dictated by market constraints. A concurrent reclamation plan will continue to be employed, to the maximum extent practicable.

The mining sequence will be initiated by the stripping and stockpiling of topsoil and overburden in onsite stockpiles and perimeter berms for noise and visual screening purposes. All stored material will eventually be used as needed for reclamation purposes. Topsoil will be placed at a minimum depth of not less than 6 inches prior to seeding. It is anticipated that removal of unconsolidated overburden will be sequenced in advance of active mining faces to allow for a maximum of approximately one year's mining. Removal of vegetative cover such as grasses, brush, shrubs, and trees will also be restricted to that area required for approximately one year's mining to minimize erosion and habitat disturbance.



The topsoil and overburden depth ranges from 0 ft to 20 ft within the expanded LOM based on the analysis of geologic drilling logs and soil maps within the expansion area. The average expected topsoil soil depth stripped ranges from 5 ft to 6 ft.

To the greatest extent possible, topsoil and overburden will be stockpiled separately. Any newly generated topsoil and overburden stockpiles and berms will be constructed with slopes no greater than one-and-one-half horizontal to one vertical (1.5h:1v) to minimize erosion and ensure stable slopes. The height of the stockpiles will be variable. Stockpiles and berms will be constructed in a neat, orderly fashion in accordance with typical industry practices, and will be stabilized with vegetation.

Haul roads, in addition to those already in existence, will be constructed as necessary within the mine site to provide access to all excavation areas.

2.3.1.3 Grading and Setbacks

All New York State Department of Environmental Conservation (NYSDEC) setback requirements will be observed around the perimeter of the mine site, including that of the expansion area. All other NYSDEC slopes and grading requirements will continue to be followed. The outer perimeter of the affected area will remain set-back at least 25 feet from the property line. Final sand and gravel slopes will be graded to slopes not exceeding 1.5:1. Active excavation areas will be graded internally to prevent stormwater from leaving the site and allow stormwater to return to the groundwater regime via percolation into the relatively high permeability sands and gravels. The floor of the pit will remain at least 5 feet above the seasonal high-water table. IGN will periodically dig test pits in the mine floor and/or in advance of mining to confirm water table depth. Please see Sheets 1-3 for additional grading and setback information.

2.3.1.4 Roadways

There will be no additional access points from public roadways into the mine site as a result of the expansion area. Internal haul routes will be progressively adjusted, as is the current practice, to access active excavation areas. As mining activity progresses, internal roads will be



systematically "mined-out" or reclaimed as they are no longer required to access portions of the site.

2.3.1.5 Disposal of Waste Materials

Expanded mining operations will not result in an increase in waste from the mine site. Clearing of a limited amount of vegetation will be required in advance of mining activities. Consistent with typical industry practices, stripped materials such as brush, shrubs and trees and will either be chipped and mulched for reclamation purposes or sale, buried on-site, or removed to an approved landfill.

2.3.1.6 Traffic

By law, all trucks are required to comply with NYS Vehicle Code 380a-1, which pertains to loose cargo. IGN will require all of its on-road trucks to comply with the code and will encourage all independent or non-IGN trucks visiting the mine to comply as well.

Truck traffic to and from the site will not be increased by the proposed expansion, as the increase in affected area is a continuation of existing mine operations. The amount of material shipped from the site is controlled by market demand and specific contracts. Continued mining at the site will not create an increase in market demand but will only increase the sand and gravel reserves.

2.3.1.7 Hours of Operation

IGN anticipates that the hours of operation and observed holidays will continue to be the same as those currently used at the site. Current typical hours of operation are 6:00AM to 8:00PM Monday through Saturday. The site does not operate on designated holidays.

Major infrastructure improvements, including NYSDOT and local contracts for bridge replacements and paving of high traffic areas, may require delivery of materials beyond the normal hours of operation. Additionally, emergency deliveries may be required during storm events and natural occurrences beyond the control of the operator. Extended hours of operation can be defined as the time when the Padua Ridge Gravel Mine is operating (processing aggregate and loading materials for sale) beyond the typical hours of operation defined herein.



On those occasions when the Padua Ridge Gravel Mine will operate during extended hours, IGN will make all reasonable attempts to provide notice to the NYSDEC Region 8 Mined Land Reclamation Specialist prior to operating beyond normal hours of operation as defined herein.

2.3.1.8 Site Facilities

Processing Plant

No increase in the size or number of the processing units is proposed to support the continued mining activity. IGN anticipates using the same track mounted processing plant currently onsite to process material from the proposed expansion area.

Other Facilities

No new buildings will be constructed onsite as a result of continuing mining activities in the proposed expansion area.

2.4 ASSESSMENT AND MITIGATION OF POTENTIAL ENVIRONMENTAL IMPACTS

2.4.1 Potential Impacts to Air Resources

There will be no adverse impacts to the local or regional air quality as a result of the expansion of the affected area. The amount of material processed at the site is a function of market demand, not the size of the mine. Mining the proposed expansion area will not change market demand for aggregate in the area. No changes are proposed in the previously approved best management practices for the control of dust at the mine site. No changes or additions to the currently-approved and operating processing plant are proposed.

Perimeter vegetation will be maintained to trap airborne dust, preventing it from leaving the property. Vegetative cover between the mine site and Watkins Glen State Park will not be significantly reduced as a part of the proposed expansion.

Dust particles generated from internal transportation and processing of sand and gravel will be retained on the site. The size of the dust particles generated by these sources is large compared with other sources (e.g., large combustion sources), and as a result, any dust generated will quickly settle to the ground and remain on site.



IGN currently employs the following dust suppression techniques at the site and will continue to do so as mining operations continue:

1. All haulageways and access roads are sprayed with a standard water spray dust suppression system, as necessary. A water truck is available to accomplish this goal on an as-needed basis;
2. Overburden berms are graded and seeded to prevent wind erosion and help trap any fugitive dust within the property boundaries;
3. Overburden stripping is carefully controlled and will be kept to a minimum in advance of working faces;
4. Trees and other existing natural vegetation are left in place wherever possible, especially around the site perimeter; and
5. IGN requires all on-road trucks to comply with the NYS Tarp Law and encourages all independent or non-Rifenburg trucks visiting the site to comply as well.

Furthermore, IGN has and continues to comply with all applicable regulatory requirements associated with the operation of the mine site. Operations are routinely monitored to ensure compliance with all applicable requirements.

2.4.2 Potential Impacts to Vegetation and Wildlife

IGN will limit stripping areas to those needed to accommodate approximately one year's mining. This pattern will ensure that subsequent areas to be mined are left vegetated and available as wildlife habitat or agricultural land until needed for the mining operation. The proposed reclamation measures will ensure that areas are not left exposed and subject to erosion from wind and water. As discussed above, there are no unique habitats within the proposed expansion area, and there is significant similar habitat surrounding the mine site. No adverse impacts to wildlife are expected. Final restoration of each phase will provide a stable vegetative cover that could eventually provide early and mid-successional habitat.

2.4.3 Potential Impacts to Water Resources

There are no classified waterways or freshwater wetlands within the proposed expansion area.



Consistent with the approved mining method for the existing mine, the floor of the pit will remain at least 5 feet above the seasonal high-water table as expressed by on site monitoring wells. IGN will periodically dig test pits in the floor of the pit to confirm at least 5 feet of material remains above the water table. Six (6) surface water ponds are currently located within the approved affected area and serve as storm water retention and/or support agricultural operation at the site. As the site is developed, an expanded stormwater management area will be established. A more detailed discussion of stormwater management can be found in the SWPPP, included in the attached DEIS. A more detailed discussion of water resources can also be found in the attached DEIS.

2.4.4 Potential Noise Impacts

Noise generated during mining activity originates from the use of equipment to remove material from the active bank faces, haul trucks transporting materials, and the processing facilities. Potential noise impacts from the expansion of mining operations are from the equipment that will excavate and load the sand and gravel into haul trucks, as well as the haul trucks as they transport material to and from the processing facility.

Numerous measures are employed in the mine plan to minimize noise and reduce impacts to off-site receptors:

1. All equipment is muffled to MSHA standards;
2. Vegetative cover is retained in all areas outside the plant and stockpile areas that are not being mined or prepared for mining;
3. Hours of operation are restricted to periods of normal daytime activity; and
4. Natural barriers created by the active bank faces and overburden berms act as barriers to mitigate off-site noise levels when equipment is operating.

All plant employees and equipment operators are instructed in the operation of equipment to reduce noise. Below is a list of techniques utilized at the site to reduce noise:

1. Employees are instructed in the proper operation and maintenance of all equipment;



2. Employees are instructed not to "race" the engines of any equipment unnecessarily;
3. Employees are instructed to report any operating irregularities in equipment that may increase the level of noise generated by that equipment;
4. Vehicle speeds are controlled to reduce engine and ground noise during interior transport of material; and
5. All plant equipment is properly maintained and secured.

A more detailed analysis of potential noise impacts, including a Noise Projection Analysis can be found in the attached DEIS.

2.4.5 Potential Drainage and Erosion Impacts

Within the area of excavation, all drainage will be directed internally towards a dedicated storm water management area and stormwater will be allowed to percolate into the relatively high permeability sands and gravels in the floor of the excavation. An emergency spillway will be constructed to allow runoff to overflow to the Village of Watkins Glen Drainage Easement. In order to control soil erosion, stripping will be limited to haul roads, operational areas, and excavation encompassing only enough area to accommodate approximately one year's mining. Overburden will be stored in stockpiles, which will be graded and seeded to prevent erosion.

Stormwater and erosion and sediment controls are discussed in further detail within the DEIS. A SWPPP has been prepared for the site and is attached to the DEIS.

2.4.6 Potential Visual Impacts

There will be no adverse visual impacts associated with this increase in affected area. Vegetative screening will remain along southern and eastern borders of the proposed expansion areas and an audio visual screening berm will be constructed along the western border of the proposed expansion area, effectively screening the expansion area. A Visual Impact Assessment, including an expanded line-of-sight visual assessment was produced in support of the DEIS. Please see the attached DEIS for a detailed analysis of potential visual impacts.



2.4.7 Potential Traffic Impacts

Truck traffic to and from the site will not be increased by the proposed expansion of mining operations onto the leased properties. The amount of material shipped from the site is controlled by market demand and specific contracts. Continued mining and expansion at the site will not create an increase in market demand but will only increase sand and gravel reserves.



3.0 RECLAMATION PLAN

The reclamation objective for the Padua Ridge Gravel Mine is vegetated open space. The Reclamation Plan (Sheet 2) and Final Grade Profiles (Sheet 3), show the final configuration of the mine site after all mine faces are graded. Final floor elevations as shown on Sheets 2 and 3 are approximate and may vary slightly based on depth to the seasonal high groundwater table at specific locations across the site. Mining activity will remain at least five (5) feet above the seasonal high groundwater table. Reclamation grades will not exceed 1.5H: 1V.

3.1 RECLAMATION SCHEDULE

As excavation areas reach their final extent and depth, they will be reclaimed. Reclamation will include grading of slopes, redistribution of soils, and planting with an appropriate seed mixture. However, haul roads and processing equipment will be used continuously until mining is terminated. The remainder of the mine site will be prepared for revegetation after all mining is completed. For the best results, revegetation will be scheduled to occur in the spring or fall.

3.2 SEQUENTIAL RECLAMATION PLANS

Concurrent reclamation will be employed to the extent practicable to minimize the exposed (unvegetated) land surface necessary for mining and thereby reduce dust, erosion and visual impacts.

3.3 HAUL ROADS

The mine site's access road and primary internal haul roads will be maintained to provide continuing access to all areas of the site. Haul roads will not be reclaimed until excavation has reached the maximum extent and final reclamation of the mine site has commenced. Secondary internal haul roads will be reclaimed as soon as practicable. Reclamation of haul roads will include grading to approved slopes, placement of soil sufficient to support vegetation and revegetation as outlined in the following sections.



3.4 STORMWATER TREATMENT PONDS

Stormwater ponds will be left in-place for future use or allowed to fill with sediment over time. The storm water ponds will continue to provide detention and/or retention through reclamation activities and will provide a potential ecological resource at completion of reclamation.

3.5 DISPOSITION OF MATERIAL

Vegetative debris from stripping activities will be buried onsite, stored for reclamation, sold, or transported to an approved landfill. Stockpiled topsoil/overburden will be spread across the excavation areas at the mine site during reclamation to a depth adequate to establish vegetative cover.

3.6 REVEGETATION

Upon completion of grading, excavation areas will be reclaimed utilizing an appropriate seeding program. The areas to be reclaimed will be seeded during the first planting season after land preparation.

IGN will employ an appropriate conservation seeding mix and, if necessary, apply mulch to ensure the successful establishment of vegetation. The following is a typical seeding program and may be altered, subject to NYSDEC consultation:

Seeding Mixture:

Big Bluestem	10 pounds/acre
Switchgrass	10 pounds/acre
Little Bluestem	10-15 pounds/acre
Crown Vetch	10 pounds/acre
Tall Fescue	5-10 pounds/acre

Lime and Fertilizer (if necessary):

10-20-20 fertilizer at 150-200 pounds per acre, or as recommended following soil testing

Mulch (if necessary):

1,500-2,000 pounds per acre.

FIGURE

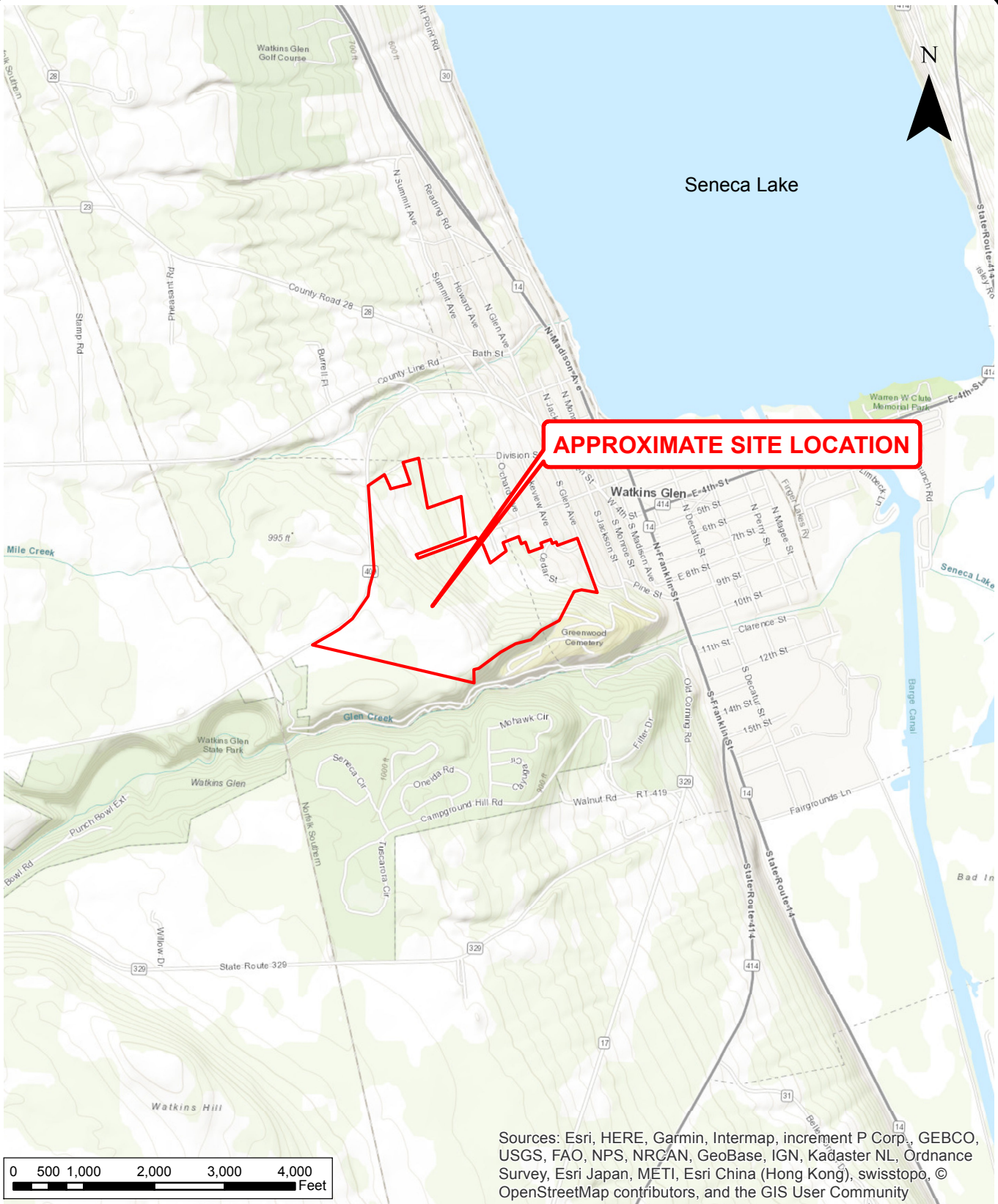

Sources: Esri, HERE, Garmin, Intermap, increment P Corp., GEBCO, USGS, FAO, NPS, NRCAN, GeoBase, IGN, Kadaster NL, Ordnance Survey, Esri Japan, METI, Esri China (Hong Kong), swisstopo, © OpenStreetMap contributors, and the GIS User Community



19 British American Blvd., Latham, New York 12110
 P: (518) 782-0882 F: (518) 782-0973 www.jmt.com

SITE LOCATION MAP
IT'S GREENER NOW, INC.
 PADUA RIDGE GRAVEL MINE
 TOWN OF DIX SCHUYLER CO., NY

SHEETS

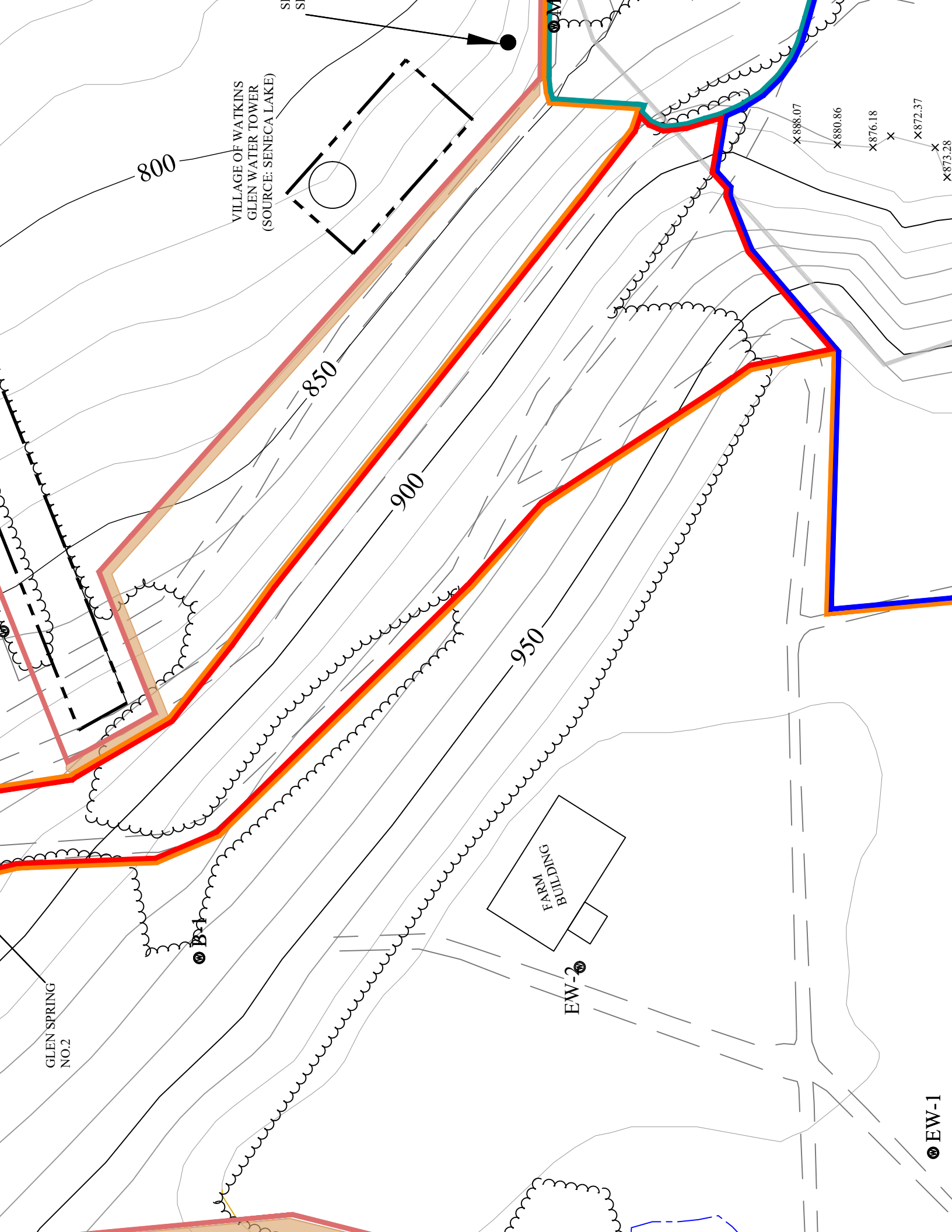

800

VILLAGE OF WATKINS
GLEN WATER TOWER
(SOURCE: SENECA LAKE)

850

900

950

X 888.07

X 880.86

X 876.18

X 872.37

X 873.28

GLEN SPRING
NO.2

FARM
BUILDING

⊙ B-1

⊙ EW-2

⊙ EW-1

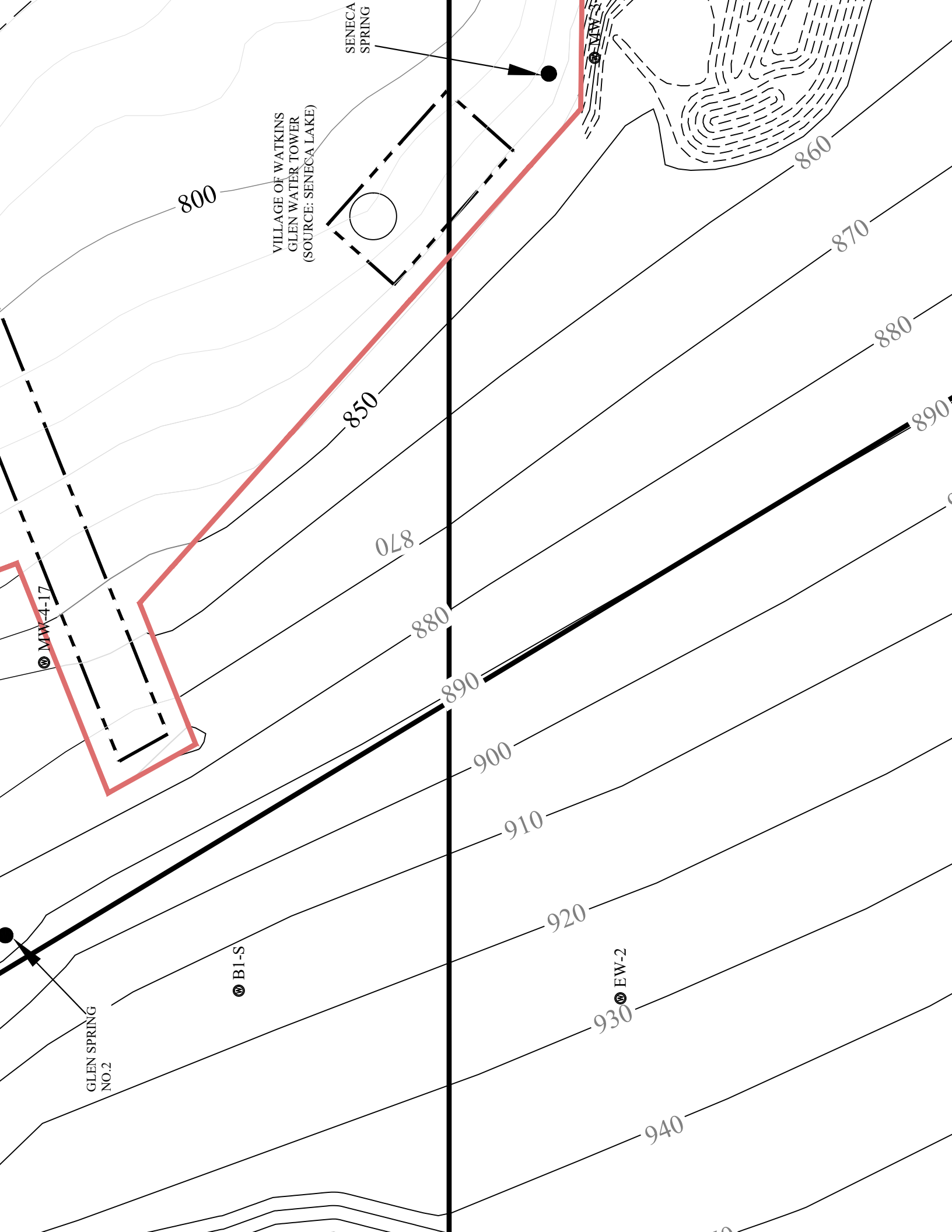

SENECA SPRING

VILLAGE OF WATKINS
GLEN WATER TOWER
(SOURCE: SENECA LAKE)

800

860

870

880

850

890

870

880

890

900

910

920

930

940

MW-4-17

B1-S

EW-2

GLEN SPRING
NO.2

MW-5

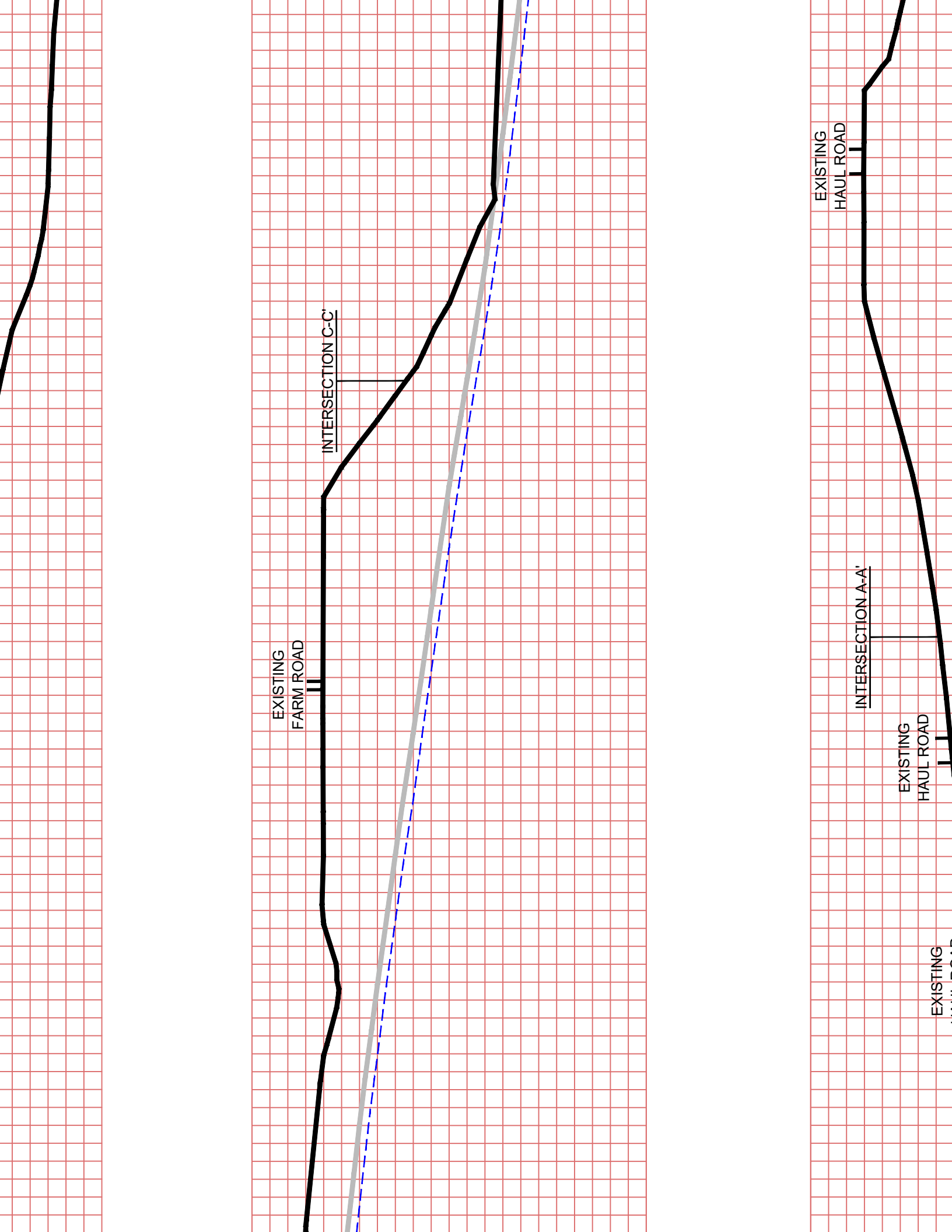

EXISTING
FARM ROAD

INTERSECTION C-C

EXISTING
HAUL ROAD

INTERSECTION A-A'

EXISTING
HAUL ROAD

EXISTING
HAUL ROAD

APPENDIX A
MINED LAND RECLAMATION PERMIT APPLICATION
ORGANIZATIONAL REPORT FORM

Division of Mineral Resources
MINING PERMIT APPLICATION



Department of
**Environmental
 Conservation**

1. a. MINE FILE NUMBER 80244		1. b. DEC ID NUMBER 8-4424-00006/00001		7. MINED LAND PROJECT	
2. NAME OF APPLICANT It's Greener Now, Inc.		3. TELEPHONE NUMBER (607)-535-5525		a. Will the total acreage affected by mining for the entire mining site be equal to or greater than 5 acres? Yes <input checked="" type="checkbox"/> No <input type="checkbox"/>	
4. PERMANENT ADDRESS: NUMBER & STREET NAME 3362 Route 409		CITY: Watkins Glen STATE: NY ZIP CODE: 14891		b. Will the vertical depth from the top of the mine face to the floor exceed 20 feet? Yes <input checked="" type="checkbox"/> No <input type="checkbox"/>	
5. CONTACT PERSON Martin Wojcik		6. a. TELEPHONE NUMBER (607) 535-5525		c. Will there be on-site processing of mining products (eg. crushing, screening, washing) that requires an air permit? Yes <input checked="" type="checkbox"/> No <input type="checkbox"/>	
6. b. EMAIL ADDRESS paduaridge@yahoo.com		8. TAXPAYER ID (If other than individual, provide Federal Taxpayer ID Number) 22-3768058		d. Will mining occur within 100 feet of a surface water body (eg. stream, lake) or wetland area? Yes <input checked="" type="checkbox"/> No <input type="checkbox"/>	
10. a. PRESENT PERMIT TERM Expiration Date 10 / 24 / 2022		10. b. COMING PERMIT TERM <input checked="" type="checkbox"/> 5 years <input type="checkbox"/> Other ____ years		e. Will any consolidated materials be mined (eg. limestone, trap rock, sandstone)? Yes <input type="checkbox"/> No <input checked="" type="checkbox"/>	
12. LOCAL ORDINANCES a. Is mining prohibited at this location? <input type="checkbox"/> Yes <input checked="" type="checkbox"/> No		11. NAME OF MINERAL/MATERIAL TO BE MINED Sand & Gravel		f. Will mining occur within 500 feet of any dwelling? Yes <input checked="" type="checkbox"/> No <input type="checkbox"/>	
13. a. ARE ANY OTHER STATE MINING PERMITS CURRENTLY HELD BY THE APPLICANT? <input type="checkbox"/> Yes <input checked="" type="checkbox"/> No		12. b. Does the local government require any type of permit for mining at this location? <input checked="" type="checkbox"/> Yes <input type="checkbox"/> No		g. Will mining ever occur below the water table? Yes <input type="checkbox"/> No <input checked="" type="checkbox"/>	
14. Has any owner, partner, corporate officer or corporate director of your organization ever held any of these positions in another organization that has had a New York State mining permit SUSPENDED OR REVOKED or has had a New York State mined land reclamation bond FORFEITED ? <input type="checkbox"/> Yes <input type="checkbox"/> No If YES, identify the person(s)		13. b. If YES, give Mine File Number(s)		9. APPLICATION TYPE <input type="checkbox"/> New <input type="checkbox"/> Renewal <input checked="" type="checkbox"/> Modification <input type="checkbox"/> Transfer	
15. ACREAGE SUMMARY (To be filled in by applicant)				FOR OFFICIAL DEC USE ONLY	
a. Total acreage controlled by owner at this location		281.00 acres		_____ acres	
b. Total acreage permitted by DEC prior to this application		14.33 acres		_____ acres	
c. Total acreage affected since April 1, 1975		14.33 acres		_____ acres	
d. Total acreage approved by DEC as reclaimed since April 1, 1975		0.00 acres		_____ acres	
e. Current affected acreage (c minus d)		14.33 acres		_____ acres	
f. Acreage included in this application, but not previously approved		60.95 acres		_____ acres	
g. New acreage to be affected during the coming permit term		12.49 acres		_____ acres	
h. Number of acres to be reclaimed during coming permit term		0.00 acres		_____ acres	
16. NAME OF MINING OPERATION Padua Ridge Gravel Mine		17. MINE LOCATION Road NYS Route 409 Nearest Road Intersection Division Street Town DIX County Schuyler		18. MAP LOCATION a. Quadrangle Name Readin Center b. <input type="checkbox"/> 15 minute <input checked="" type="checkbox"/> 7 1/2 minute	
19. NAME AND ADDRESS OF SURFACE LANDOWNER(S) It's Greener Now, Inc. 3362 Route 409 Watkins Glen, NY 14891		20. NAME AND ADDRESS OF MINERAL OWNER(S) It's Greener Now, Inc. 3362 Route 409 Watkins Glen, NY 14891		FOR OFFICIAL DEC USE ONLY LATITUDE: _____ LONGITUDE: _____ NAD 83	
21. The surface landowner(s) and the mineral owner(s) of the property that is to be mined by the above applicant have read the Mined Land Use Plan, which sets forth the applicant's mining and reclamation plan for the property to be mined, and hereby irrevocably consent and agree to the performance of the Mined Land Use Plan by the applicant, his surety or insurer, or the NYS Department of Environmental Conservation. The surface landowner(s) and mineral owner(s) further agree to allow access to the property to Department personnel for the purpose of conducting inspections or investigations in the regular course of their duties.					
SIGNATURE(S) OF SURFACE LANDOWNER(S)		DATE 9/14/21		SIGNATURE(S) OF MINERAL OWNER(S)	
DATE 9/14/21		SIGNATURE(S) OF APPLICANT OR AUTHORIZED REPRESENTATIVE		DATE 9/14/21	
22. I hereby affirm under penalty of perjury that information provided on this form is true to the best of my knowledge and belief. False statements made herein are punishable as a Class A misdemeanor pursuant to Section 210.45 of the Penal Law.					

ORGANIZATIONAL REPORT



**Department of
Environmental
Conservation**

INCOMPLETE FORMS ARE NOT ACCEPTABLE AND WILL BE RETURNED FOR COMPLETION

<p>1. FULL NAME AND COMPLETE MAILING ADDRESS OF THE ENTITY; INCLUDE NAME AND TITLE TO WHOM ALL CORRESPONDENCE SHOULD BE SENT.</p> <p>Martin Wojcik President It's Greener Now, Inc. 3362 Route 409 Watkins Glen, NY 14891</p> <p>EMAIL ADDRESS: TELEPHONE (607) 535-5525 FAX NUMBER ()</p>	<p>2. FULL NAME AND COMPLETE MAILING ADDRESS OF AGENT IN NEW YORK WHO CAN BE SERVED ORDERS, NOTICES AND PROCESSES OF THE DEPARTMENT OR ANY COURT OF LAW. POST OFFICE BOX ADDRESSES ARE NOT ACCEPTABLE.</p> <p>Martin Wojcik President It's Greener Now, Inc. 3362 Route 409 Watkins Glen, NY 14891</p> <p>EMAIL ADDRESS: TELEPHONE (607) 535-5525</p>												
<p>3. TYPE OF ACTIVITY (Check those that apply)</p> <table border="0"> <tr> <td><input type="checkbox"/> PRODUCTION—Oil, Gas, Injection or Geothermal Well(s)</td> <td><input type="checkbox"/> SOLUTION MINING—Own/Operate Facility</td> </tr> <tr> <td><input type="checkbox"/> STORAGE—Underground Gas or LPG Facility</td> <td><input type="checkbox"/> BRINE DISPOSAL—Own/Operate Facility</td> </tr> <tr> <td><input type="checkbox"/> PURCHASING—Of Oil or Gas from Others</td> <td><input type="checkbox"/> STRATIGRAPHIC—Own Well or Hole</td> </tr> <tr> <td><input type="checkbox"/> TRANSPORTATION—By Truck or Pipeline for Others</td> <td><input checked="" type="checkbox"/> SURFACE MINING—Own/Operate Facility</td> </tr> <tr> <td><input type="checkbox"/> PLUGGING—Plug and Abandon Wells for Others</td> <td><input type="checkbox"/> UNDERGROUND MINING—Own/Operate Facility</td> </tr> <tr> <td><input type="checkbox"/> DRILLING—Drill Wells for Others</td> <td></td> </tr> </table>		<input type="checkbox"/> PRODUCTION—Oil, Gas, Injection or Geothermal Well(s)	<input type="checkbox"/> SOLUTION MINING—Own/Operate Facility	<input type="checkbox"/> STORAGE—Underground Gas or LPG Facility	<input type="checkbox"/> BRINE DISPOSAL—Own/Operate Facility	<input type="checkbox"/> PURCHASING—Of Oil or Gas from Others	<input type="checkbox"/> STRATIGRAPHIC—Own Well or Hole	<input type="checkbox"/> TRANSPORTATION—By Truck or Pipeline for Others	<input checked="" type="checkbox"/> SURFACE MINING—Own/Operate Facility	<input type="checkbox"/> PLUGGING—Plug and Abandon Wells for Others	<input type="checkbox"/> UNDERGROUND MINING—Own/Operate Facility	<input type="checkbox"/> DRILLING—Drill Wells for Others	
<input type="checkbox"/> PRODUCTION—Oil, Gas, Injection or Geothermal Well(s)	<input type="checkbox"/> SOLUTION MINING—Own/Operate Facility												
<input type="checkbox"/> STORAGE—Underground Gas or LPG Facility	<input type="checkbox"/> BRINE DISPOSAL—Own/Operate Facility												
<input type="checkbox"/> PURCHASING—Of Oil or Gas from Others	<input type="checkbox"/> STRATIGRAPHIC—Own Well or Hole												
<input type="checkbox"/> TRANSPORTATION—By Truck or Pipeline for Others	<input checked="" type="checkbox"/> SURFACE MINING—Own/Operate Facility												
<input type="checkbox"/> PLUGGING—Plug and Abandon Wells for Others	<input type="checkbox"/> UNDERGROUND MINING—Own/Operate Facility												
<input type="checkbox"/> DRILLING—Drill Wells for Others													
<p>4. STATE WHETHER THE ENTITY IS A CORPORATION, LIMITED LIABILITY COMPANY, ASSOCIATION, PARTNERSHIP, INDIVIDUAL, PUBLIC AUTHORITY OR GOVERNMENTAL AGENCY, OR TRUST. IF FOREIGN (OUT-OF-STATE) CORPORATION, GIVE STATE AND DATE OF INCORPORATION AND DATE OF AUTHORIZATION TO DO BUSINESS IN NEW YORK STATE. IF PARTNERSHIP, STATE WHETHER GENERAL OR LIMITED AND COUNTY OF FILING. IF DBA, GENERAL PARTNERSHIP OR ASSUMED NAME OF A LIMITED LIABILITY PARTNERSHIP, GIVE COUNTY OF FILING.</p> <p>Corporation</p>	<p>5. IF THE NAME ENTERED IN BOX 4 IS NEW, INCLUDE THE COMPLETE NAME AND ADDRESS OF THE PREVIOUS ENTITY.</p> <p>N/A</p>												
<p>6. IF ENTITY IS A CORPORATION OR ASSOCIATION, LIST ALL DIRECTORS AND ALL OFFICERS. IF A PARTNERSHIP, LIST ALL GENERAL AND ALL LIMITED PARTNERS. IF A LLC, LIST ALL MEMBERS. CHECK BOX IF ADDITIONAL SHEETS ARE ATTACHED. <input type="checkbox"/></p> <table border="1"> <thead> <tr> <th>NAME</th> <th>TITLE</th> </tr> </thead> <tbody> <tr> <td>Martin Wojcik</td> <td>President</td> </tr> </tbody> </table>	NAME	TITLE	Martin Wojcik	President	<p>7. LIST ALL PERSONS AUTHORIZED BY THE ENTITY TO SIGN ALL SUBMITTALS TO THE DEPARTMENT.</p> <table border="1"> <thead> <tr> <th>NAME</th> <th>TITLE</th> </tr> </thead> <tbody> <tr> <td>Martin Wojcik</td> <td>President</td> </tr> </tbody> </table>	NAME	TITLE	Martin Wojcik	President				
NAME	TITLE												
Martin Wojcik	President												
NAME	TITLE												
Martin Wojcik	President												

I hereby affirm under penalty of perjury that the information provided in this report is true to the best of my knowledge and belief. I am aware that false statements made in this report are punishable pursuant to Section 210.45 of the Penal Law.

<p>TYPE OR PRINT NAME OF AUTHORIZED PERSON</p> <p><i>Martin Wojcik</i></p>	<p>SWORN TO AND SUBSCRIBED BEFORE ME, THIS <u>June</u> DAY OF <u>13</u> 20<u>17</u> NOTARY PUBLIC <i>Dawn Tipperreiter</i></p>	<p>DAWN M. TIPPERREITER Notary Public - State of New Jersey Commission # 2364599 My Comm. Expires Sep. 18, 2017</p>
<p>SIGNATURE <i>Martin Wojcik</i></p>	<p>DATE <i>6/13/17</i></p>	<p><i>Dawn Tipperreiter</i></p>



DRAFT ENVIRONMENTAL IMPACT STATEMENT
It's Greener Now, Inc. – Padua Ridge Gravel Mine Town of Dix, New York

APPENDIX G

STORMWATER POLLUTION PREVENTION PLAN



STORMWATER POLLUTION PREVENTION PLAN

**IT'S GREENER NOW, INC.
PADUA RIDGE GRAVEL MINE**

**TOWN OF DIX
SCHUYLER COUNTY, NEW YORK**

Prepared for:

It's Greener Now, Inc.
3362 Route 409
Watkins Glen, New York 14891

SPDES Permit No. NYR 00 ___ (Multi-Sector General Permit)

Prepared by:

JMT of New York, Inc.
19 British American Boulevard
Latham, New York 12110

Submitted: June 2022

Project No: 16-S0157N-001

A decorative graphic in the bottom right corner of the page, consisting of several overlapping, diagonal, triangular shapes. The shapes are in shades of blue and gray, with the darkest blue being a solid color and the lighter shades having a fine, dotted or halftone texture. The shapes point towards the top right corner of the page.



TABLE OF CONTENTS

1.0	INTRODUCTION.....	1
2.0	MANAGEMENT APPROVAL	3
3.0	POLLUTION PREVENTION TEAM.....	4
4.0	GENERAL SITE DESCRIPTION.....	5
5.0	SUMMARY OF POTENTIAL POLLUTANT SOURCES	8
6.0	SPILLS AND RELEASES	10
6.1	PETROLEUM AND CHEMICAL HANDLING PROCEDURES.....	10
6.2	SPILL PREVENTION RESPONSE PROCEDURES	11
6.3	CORRECTIVE ACTION DOCUMENTATION ASSOCIATED WITH SPILLS AND RELEASES	13
7.0	STORMWATER CONTROLS, BMPS AND MAINTENANCE.....	14
8.0	MONITORING AND SAMPLING DATA	16
9.0	NON-STORMWATER DISCHARGES	17
10.0	COPY OF PERMIT REQUIREMENTS.....	18
11.0	SIGNATURE AND PLAN REVIEW.....	19
12.0	SWPPP AMENDMENTS.....	20
13.0	SPECIAL SWPPP REQUIREMENTS.....	21
14.0	SALT STORAGE	22
15.0	MONITORING, REPORTING AND RECORD RETENTION.....	23
15.1	WEEKLY (REFER TO SECTION 16.3).....	23
15.2	MONTHLY	23
15.3	QUARTERLY VISUAL EXAMINATION	23
15.4	NUMERIC EFFLUENT LIMITATIONS	25
15.5	SEMI-ANNUAL BENCHMARK MONITORING	25
15.6	ANNUAL COMPREHENSIVE SITE COMPLIANCE EVALUATION AND INSPECTION	26
15.7	ANNUAL CERTIFICATION REPORT.....	28
16.0	SECTOR SPECIFIC PERMIT REQUIREMENTS	29
16.1	NON-STORMWATER DISCHARGES	29
16.2	QUARTERLY INSPECTIONS	29
16.3	WEEKLY INSPECTIONS.....	29

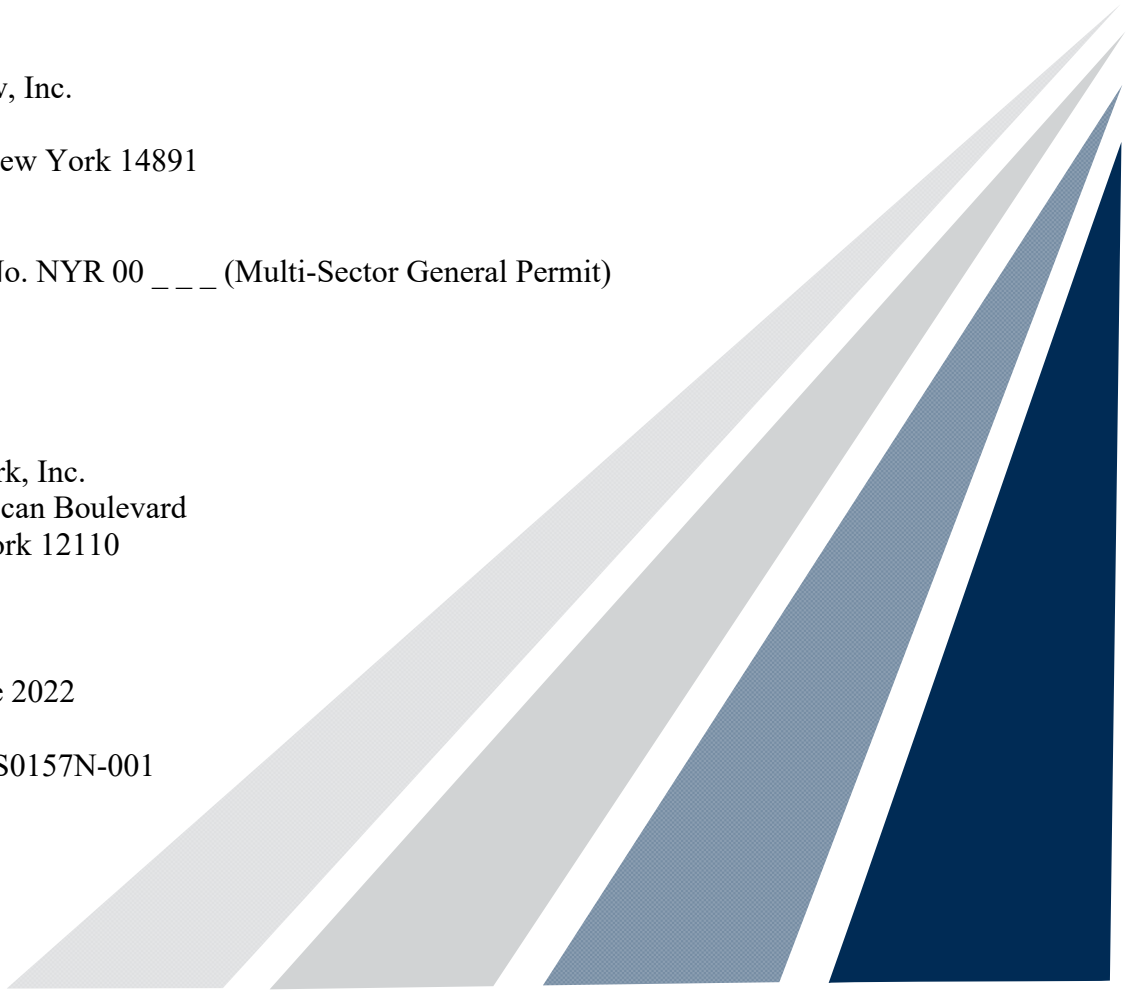

FIGURE

FIGURE 1 SITE LOCATION MAP

PLATE

PLATE 1 SITE PLAN

APPENDICES

APPENDIX A DRAINAGE REPORT

APPENDIX B ANNUAL SITE COMPLIANCE EVALUATION REPORT

APPENDIX C MONTHLY STORMWATER MANAGEMENT FEATURE INSPECTION REPORT FORM

APPENDIX D QUARTERLY VISUAL MONITORING FORM

APPENDIX E DISCHARGE MONITORING REPORT FORM

APPENDIX F ANNUAL CERTIFICATION REPORT

APPENDIX G SPDES MULTI-SECTOR GENERAL PERMIT (GP-0-17-004)

APPENDIX H NON-STORMWATER DISCHARGE CERTIFICATION

APPENDIX I NOTICE OF INTENT (NOI)

APPENDIX J ANALYTICAL LABORATORY RESULTS

APPENDIX K WEEKLY INSPECTION FORM



1.0 INTRODUCTION

Stormwater Pollution Prevention Plans (SWPPPs) must be developed and implemented by the operators for each facility covered by the National Pollutant Discharge Elimination System (NPDES) permit. In many states, such as New York, the state governmental environmental department, known as the New York State Department of Environmental Conservation (NYSDEC), issues State Pollutant Discharge Elimination System (SPDES) permits.

Terms and conditions of the NYSDEC SPDES Multi-Sector General Permit for stormwater discharges associated with industrial activities GP-0-17-004 requires facilities to develop a SWPPP that describes practices implemented at the facility that reduce the pollutants in stormwater discharges associated with industrial activities. Facilities are obligated to implement the provisions of the SWPPP as a condition of the SPDES Permit. In some cases, requirements of the SPDES Permit may be fulfilled by incorporating other plans or documents (e.g Spill Prevention Control and Countermeasure Plan, Erosion and Sediment Control Plan, SWPPP for construction activities, etc.) otherwise required for the facility by reference. All plans incorporated by reference into this SWPPP are enforceable under the SPDES General Permit.

This SWPPP has been developed by JMT of New York, Inc. (JMT) for It's Greener Now, Inc.'s (IGN) Padua Ridge Gravel Mine, located in the Town of Dix, Schuyler County, New York, in accordance with good engineering practices and the requirements set forth in the SPDES Multi-Sector General Permit for stormwater discharges associated with industrial activity except construction activity (GP-0-17-004).

Stormwater runoff is rainwater or snowmelt that runs off land into streams, rivers, and lakes. When stormwater runs through industrial sites, it has the potential to pick up pollutants and transport them into national waterways thereby affecting the quality of navigable waters. The SWPPP must identify the members of the pollution prevention team who will be responsible for assisting the facility in developing, implementing, maintaining and revising the SWPPP, and with responding to emergencies that may adversely affect stormwater quality at the facility. This plan has been developed to identify potential pollutant sources and operational practices at the facility that may reasonably be expected to affect the quality of stormwater discharges associated with industrial activity on this site.



STORMWATER POLLUTION PREVENTION PLAN
It's Greener Now, Inc. – Padua Ridge Gravel Mine Town of Dix, New York

The SWPPP describes measures and controls that are to be used to reduce or prevent pollutants in stormwater discharges. Measures and controls described herein include good housekeeping, preventive maintenance, operating procedures, sediment and erosion control, management of

stormwater runoff, personnel training, record keeping, inspections, site security, and practices to control site runoff, spills or releases, sludge or waste disposal, or drainage from raw material storage. This plan is to be maintained on-site and is to be reviewed and updated as required - at least annually.



2.0 MANAGEMENT APPROVAL

The Stormwater Pollution Prevention Plan (SWPPP) will be implemented as herein described. I certify under penalty of law that this document and all attachments were prepared under my direction or supervision in accordance with a system designed to assure that qualified personnel properly gathered and evaluated the information submitted. Based on my inquiry of the person or persons who manage the system, or those persons directly responsible for gathering the information, the information submitted is, to the best of my knowledge and belief, true, accurate, and complete. I am aware that there are significant penalties for submitting false information, including the possibility of fine and imprisonment for knowing violations.

Signature _____

Martin Wojcik
President



3.0 POLLUTION PREVENTION TEAM

The Padua Ridge Gravel Mine has designated the individuals identified in Table 1 as the Pollution Prevention Team. The team is responsible for assisting with developing, implementing, maintaining and revising the SWPPP, and responding to emergencies at the sand and gravel mining operation that may adversely affect stormwater quality. Individual responsibilities range from implementation of this plan, employee training, inspections, record keeping, implementation of best management practices, and documenting operational or facility changes and reporting them to the appropriate personnel. The pollution prevention team shall consist of the following team leader and members who are assigned the following responsibilities:

Table 1: Pollution Prevention Team

Team Leader:	Martin Wojcik
Title:	President
Office Phone:	(607) 535-5525
Responsibility:	<ul style="list-style-type: none"> • Implementation of the SWPPP and all SPDES MSGP requirements. • Overseeing the content of the SWPPP • Providing signatory authority • Coordinating employee training • Ensuring Quarterly Visual Monitoring and stormwater sampling are being completed as required • Ensuring Annual Comprehensive Site Evaluations, including dry weather flow monitoring are being completed • Ensuring that Annual Certification Reports and Discharge Monitoring Reports are submitted to the NYSDEC by January 28 following the permit year.
Name:	Jim Jacey
Title:	Site Manager
Office Phone:	(607) 342-5293
Responsibility:	<ul style="list-style-type: none"> • Providing support to the President. • Responding to spills and determining whether additional (outside) response is necessary. • Ensuring that operating equipment is receiving preventative maintenance as required by the equipment manufacturer. • Implementing good engineering practices and best management practices identified in the SWPPP • Conducting routine inspections. • Recordkeeping of monthly, quarterly, and annual inspections.



4.0 GENERAL SITE DESCRIPTION

The Standard Industrial Classification (SIC) code associated with the quarry is 1442 – Construction Sand and Gravel, which is included in the United States Department of Labor, Occupational Safety and Health Administration's Division B – Mining; Major Group 14 – Mining and Quarrying of Non-Metallic Minerals. Sand and gravel are processed on-site.

The Padua Ridge Gravel Mine (the facility) is an operating mine site (NYSDEC Mined Land File #80244). Operations at the site currently include the extraction of sand and gravel. The extracted sand and gravel is processed in on-site screening plants, which includes material washing. The screened and washed material is offered for sale.

The facility is located east of Route 409 in the Town of Dix, Schuyler County, New York. Figure 1, "Site Location Map," illustrates the location of the mine site and its relationship to the surrounding area. The entire property is approximately 281 +/- acres, bound by Route 409 to the west, Watkins Glen State Park to the southwest and St. Mary's Cemetery to the southeast. The proposed life-of-mine affected area is 75.28 +/- acres.

Typical operating hours for the facility are 7 days a week, 5:00 am to 7:00 pm Monday through Friday, and 8:00 am to 5:00 pm Saturday and Sunday for truck loading only.

A Site Location Map that identifies the location of the facility and the receiving waters within one mile is provided as Figure 1. A Site Plan that identifies the direction of stormwater flow and shows locations of existing structural Best Management Practices (BMPs), surface water bodies, potential pollutant sources, major spills or leaks (if applicable), stormwater outfalls and approximate areas draining them, non-stormwater discharges, stormwater flows with significant potential for causing erosion, and locations of run-off from adjacent properties which may contain significant quantities of pollutants of concern to the facility is provided in Plate 1.

The facility has a processing plant, a scale house, a barn, and a farm garage. (See Plate 1, Site Plan.) There are no registered petroleum bulk storage tanks associated with the mine site. Delivery fuel trucks supply the equipment in the pit.

The facility topography generally decreases from southwest to northeast. The existing stormwater flow follows in this manner, from southwest to northeast. The proposed stormwater



STORMWATER POLLUTION PREVENTION PLAN
It's Greener Now, Inc. – Padua Ridge Gravel Mine Town of Dix, New York

management system at the facility will capture and direct stormwater runoff from the anticipated impervious surfaces, including the internal roads, any on-site structures, and the mine itself into a stormwater management area for treatment. An emergency spillway within the stormwater management area will be constructed to allow runoff to overflow to the Village of Watkins Glen Drainage Easement, when the demand is needed (Outfall 001). Overflow should only occur when a storm event exceeds the 100-year event, if the stormwater management system is properly maintained. Please refer to Plate 1, Site Plan for specific locations of the anticipated stormwater management features.

The Watkins Glen Drainage Easement drains to Quarter Mile Creek. Quarter Mile Creek is a NYSDEC Class “C” Stream approximately 700 feet north of the mine site which discharges to Seneca Lake. Class “C” waters are best used for fishing and primary and secondary contact recreation, although other factors may limit the use for these purposes.

The dominant surface water feature in the area is Seneca Lake, which is located approximately 0.56 miles northeast of the site. The portion of Seneca Lake closest to the facility falls under the jurisdiction of NYSDEC, Region 8 and is designated as class “B” with a standard of “(T)”, indicating it may support a trout population. According to the NYSDEC, class “B” waters are best suitable for primary and secondary contact recreation and fishing, and for fish, shellfish, and wildlife propagation and survival.

The closest water body to the facility is Glen Creek, which is approximately 500 feet south of the site. In the vicinity of the mine site, Glen Creek is designated as class “B”. As stated above, the best usages of class “B” waters are primary and secondary contact recreation and fishing. These waters are also suitable for fish, shellfish and wildlife propagation and survival.

None of these water bodies are considered Total Maximum Daily Load (TMDL) watershed or Section 303(d) segments.

Although the drainage sub-basin, Seneca Lake Inlet (where the facility is located in) is not associated with class “AA”, the section of Seneca Lake north of the portion closest to the facility is designated as class “AA” (located in Seneca / Big Stream sub-basin) and is highly valued, because it is a source of water supply for drinking. The Best Management Practices (BMPs) and procedures described within this plan will ensure the integrity of stormwater discharges at the



STORMWATER POLLUTION PREVENTION PLAN
It's Greener Now, Inc. – Padua Ridge Gravel Mine Town of Dix, New York

facility and mitigate any impacts to the class “AA” waterbody / watershed. Please refer to Sections 5.0 and 8.0 below for the site-specific BMPs.

The facility entrance drains into the site, away from NYS Route 409. Stormwater runoff from this area is captured by a catch basin system, consisting of three catch basins alongside the internal access road. The system is connected underground and terminates at the surface through a pipe, which discharges to a vegetated depression within the property boundaries (Outfall 002). This outfall will be terminated prior to upgradient excavation activities. Runoff from this area will be contained by existing or newly constructed/relocated berms and will infiltrate the relatively high permeability site sand and gravel or evaporate.

Approximately 9.8% of the site is impervious surfaces.



5.0 SUMMARY OF POTENTIAL POLLUTANT SOURCES

Potential pollutants at this site include suspended solids (sediment) and petroleum products. Untreated runoff with large amounts of sediment can increase the total suspended solids in receiving water bodies, resulting in damage to aquatic habitats and reducing the quality of navigable waters. The following provides a summary of potential pollutant sources that could affect stormwater runoff quality at this facility. Also included are all structural BMPs that are used for each activity to control stormwater discharge and prevent the mixing of stormwater and process water.

Activity 1 – Sand and Aggregate Stockpiles

Pollutants – Suspended Solids

Potential for Presence in Stormwater – Uncovered sand and aggregate stockpiles are located throughout the facility within the property boundaries. Stormwater that comes in contact with these uncovered sand and aggregate stockpiles either infiltrates into the ground or flows toward one of the conveyance structures to ultimately be diverted into the stormwater management area, where it will be treated and maintained. In the event the basin cannot accommodate the quantity of stormwater, the overflow will be discharged to the Village of Watkins Glen Drainage Easement through an emergency spillway (Outfall 001).

There is a berm located along the perimeter of NYS Route 409 to prevent stormwater from leaving and entering the property to the west.

Non-Structural BMPs to be implemented for this area include good housekeeping practices around stockpiles to maintain an orderly and safe work environment. Additionally, applicable facility personnel shall have SWPPP training.

Activity 2 – Conveyors and Processing Equipment

Pollutants – Suspended Solids

Potential for Presence in Stormwater – Aggregate materials are moved from the storage areas via front-end loaders where materials are placed on a conveyor that transports the material to the processing plant. Stormwater that comes in contact with aggregate material within the conveyors flows onto the ground where it infiltrates into the ground or flows toward the stormwater management area, where it will be treated and maintained. In the event the basin cannot



STORMWATER POLLUTION PREVENTION PLAN
It's Greener Now, Inc. – Padua Ridge Gravel Mine Town of Dix, New York

accommodate the quantity of stormwater, the overflow will be discharged to the Village of Watkins Glen Drainage Easement through an emergency spillway (Outfall 001).

Non-Structural BMPs to be implemented for this area include good housekeeping practices around stockpiles to maintain an orderly and safe work environment. Additionally, applicable facility personnel shall have SWPPP training.

Activity 3 – Heavy Equipment, Tractor Trailers, and Vehicles

Pollutants – Suspended Solids and Petroleum Products

Potential for Presence in Stormwater – Heavy equipment and vehicles such as front-end loaders, tractor trailers, dump trucks, and personal vehicles are used throughout the site for an assortment of reasons. Front-end loaders are used to move aggregate material. Tractor trailers and dump trucks are used to deliver and transport materials to and from the site. On-site vehicles are owned by the company, company personnel, and site visitors. When vehicles are not actively being used, they are typically parked next to the scale house or in the equipment storage area.

Stormwater that comes in contact with heavy equipment, tractor trailers, and company vehicles, while they are actively being used throughout the site typically infiltrates into the ground or flows into one of the conveyance structures to be diverted to the stormwater management area for treatment or flows overland and is captured by one of the catch basins prior to discharge through Outfall 002. Suspended solids settle to the bottom and petroleum products will float on top of the water. If petroleum products are observed on the water, it must be cleaned up immediately (no later than 2 hours after its discovery) with absorbents and/or booms.

Activity 4– Vehicle and Heavy Equipment Fueling Operations

Pollutants – Petroleum Products

Potential for Presence in Stormwater – Vehicle and heavy equipment fueling operations at the facility occur near the scale house and in the excavation area. Stormwater that comes in contact with the fueling area either infiltrates into the ground or flows overland into the stormwater management area. Suspended solids settle to the bottom and petroleum products will float on top of the water. If petroleum products are observed on the water, it must be cleaned up immediately (no later than 2 hours after its discovery) with absorbents and/or booms.



Activity 5 – Mining

Pollutants – Suspended Solids

Potential for Presence in Stormwater – Sand and gravel material is excavated using heavy equipment. Mining operations occur within the life of mine boundary. Stormwater that comes in contact with mining activities either infiltrates into the ground or flows northeast into the stormwater management area located northeast of the processing plant. Suspended solids settle to the bottom of the basin. Sediment should be removed from the stormwater management basin when it reaches 50% capacity – basin capacity should be checked at least semi-annually. An emergency spillway will also be constructed to allow excess runoff to overflow to the Village of Watkins Glen Drainage Easement (Outfall 001) in the event of large storm events. The stormwater management system is designed to contain at least a 100-year storm.

6.0 SPILLS AND RELEASES

Areas where potential spills and leaks can contribute to pollutants in stormwater discharges and drainage points from this facility include locations where heavy equipment, tractor trailers, and vehicles are used or fueled, the parking area, petroleum bulk storage tank areas or equipment maintenance operation areas.

6.1 PETROLEUM AND CHEMICAL HANDLING PROCEDURES

The facility will implement the following stormwater management controls and BMPs to reduce the pollutants in potential stormwater discharges to assure compliance:

- All product unloading from petroleum delivery trucks is to be performed under the supervision of the delivery truck driver or facility personnel;
- Loading operations are to be performed manually via a tanker truck for storage tanks;
- Loading operations are not complete until the delivery driver or facility personnel have disconnected the fill, inspected each tank or drum for leakage, and ensured that no product has been released during transfer or loading activities;
- All petroleum bulk storage tanks are to be inspected visually on a monthly basis;



- Facility equipment that contains potential pollutant sources (e.g. petroleum or chemical products) must be inspected and maintained on a periodic basis to avoid breakdowns or failures;
- Ensure spill/overflow protection on equipment and drain fluids from equipment and vehicles prior to onsite storage or disposal;
- Perform all cleaning operations indoors, under cover, or in bermed areas that prevent runoff and run-on;
- Ensure that all wash water drains to a proper collection system (i.e., not the stormwater drainage system); and
- Minimize exposure of chemicals by replacing with a less toxic alternative.

6.2 SPILL PREVENTION RESPONSE PROCEDURES

Spill Prevention and Response procedures will be used to minimize the potential for leaks, spills and other releases from entering any body of water. Good housekeeping and preventative maintenance practices will also help prevent spills before they occur.

Prevention:

- Plainly label containers that could be susceptible to spillage or leakage and encourage proper handling;
- When possible use barriers between material storage and traffic areas, secondary containment provisions, and procedures for material storage and handling;
- Have necessary spill response equipment available; expeditiously stopping, containing, and cleaning up leaks, spills, and other releases; and
- The Stormwater Pollution Prevention Team will evaluate the spill and spill response activities to make recommendations or plan updates to prevent any recurrence of the same type of spill.

MSHA daily workplace inspection of manufacturing equipment for leaks as follows:

- Onsite personnel in attendance of fuel deliveries; Increased training on spill prevention and cleanup; and



STORMWATER POLLUTION PREVENTION PLAN
It's Greener Now, Inc. – Padua Ridge Gravel Mine Town of Dix, New York

- Off-site removal of any oils, lubricants not required for daily operation. No unnecessary storage of petroleum products.

Response Procedures:

1. *Assess the situation:* Determine whether ignition sources or other safety issues exist. If a fire potential or life-threatening situation exists, evacuate the area and immediately notify a SWPPP Coordinator who should contact the appropriate emergency personnel. If a fire or life-threatening situation exists, await instruction from emergency crews—do not attempt to stop or contain the spill unless instructed by emergency crew to assist.
 2. *Stop the flow:* Take measures (i.e., turn off pumps, close valves, etc.) to reduce the flow.
 3. *Contain the spill:* Prevent discharges from reaching drainage or watercourses. Examine containment system, if applicable, for integrity. Contain localized spills with absorbent materials. Construct temporary earthen berms, dikes, channels, or impoundment areas where appropriate. If a release threatens to enter storm water catch basins, perform emergency catch basin shutdown procedures by using drain covers or by constructing a berm around the catch basin using absorbent booms.
 4. *Clean up the spill:* Use enough absorbent to soak up the spilled liquid. If spilled liquid is flammable, use non-sparking shovels to prevent ignition. Scoop up spent absorbent and place in the proper waste container. Properly label waste container if material is flammable and combustible.
- Notify Stormwater Pollution Prevention Team Leader: **Martin Wojcik, cell: (607) 535-5525**
 - Notification to the proper authorities (i.e., Fire Department, NYSDEC, etc.) will be made and reportable spills of a hazardous substance must be reported to the NYSDEC hotline (1-800-457-7362) within two hours of the release.
 - Document spill and retain in SWPPP.

General Spills and Clean-Up:

- Residue or materials resulting from the clean-up will be properly disposed and the results documented;
- Liquid spill area to be contained using spill kit absorbents and the results documented. In the event of a large spill a local spill contractor will be contacted; and
- Clean up leaks, drips, and other spills without using large amounts of water. Use



absorbents for dry cleanup whenever possible.

6.3 CORRECTIVE ACTION DOCUMENTATION ASSOCIATED WITH SPILLS AND RELEASES

In accordance with the conditions listed in Part V.B of GP-17-004 (non-stormwater discharges), owners or operators must document within 24 hours of becoming aware of such condition. Unless required by Part VI.A.2.b or as requested by the Department, the corrective action documentation is not required to be submitted and should be kept with the facility's SWPPP. Include the following information in your documentation:

- a. A description of the condition triggering the need for corrective actions. For any spills or leaks, include the following information: a description of the incident including material, date/time, amount, location, and reason for spill, and any leaks, spills or other releases that resulted in discharges of pollutants to waters of the state, through stormwater or otherwise;
- b. Date the condition was identified;
- c. The date when each corrective action was initiated and completed (or is expected to be completed);
- d. A description of the corrective actions to minimize or prevent the discharge of pollutants. For any spills or leaks, include response actions, the date/time clean-up completed, notifications made, and staff involved. Also include any control measures taken to prevent the reoccurrence of such releases (see Part II.A.4); and
- e. A statement, signed and certified in accordance with Appendix H.8.



7.0 STORMWATER CONTROLS, BMPS AND MAINTENANCE

Potential pollutant sources were discussed in detail in Section 5.0 of this report. Section 5.0 includes a total of five activities where industrial materials or activities are exposed to stormwater.

Non-Structural BMPs to be implemented throughout the facility include good housekeeping practices in order to maintain safe, orderly, and clean work environments. Specifically, work areas are to be kept clear of obstructions and debris to the greatest extent practicable. Dormant equipment is to be stored in appropriate locations (e.g. covered or stormwater isolated areas, or offsite) when possible to minimize the potential for stormwater exposure. Unpaved areas are maintained in good condition to minimize erosion.

All product unloading from petroleum delivery trucks is to be performed under the supervision of the delivery truck driver and facility personnel. Loading operations are to be performed manually via a tanker truck for any storage tanks. Loading operations are not complete until the delivery driver and facility personnel have disconnected the fill, inspected each tank for leakage, and ensured no product has been released during transfer or loading activities.

All stormwater management features are to be routinely visually inspected monthly and any necessary maintenance or repairs that may be required to keep them working properly are to be completed as soon as practicable. Facility equipment that contains potential pollutant sources (e.g. petroleum or chemical products) must be inspected and maintained on a periodic basis to avoid breakdowns or failures.

Facility personnel must be familiar with the requirements contained in this SWPPP. Training must address proper disposal methods, proper care and maintenance of stormwater features, SWPPP measures and controls, spill prevention, containment, cleanup, and methods to minimize exposure to chemical and petroleum constituents. Training must also include the proper procedures to follow with respect to the SPDES MSGP's pollution prevention requirements, including sampling and reporting, how to recognize unauthorized discharges, and when and how to conduct inspections, record applicable findings and take corrective actions. Training refreshers are to be conducted at regular intervals (at least annually) to ensure adequate understanding of this SWPPP.



STORMWATER POLLUTION PREVENTION PLAN
It's Greener Now, Inc. – Padua Ridge Gravel Mine Town of Dix, New York

Structural BMPs have been identified and discussed in Section 5.0 of this report (Summary of Potential Pollutant Sources) and are further detailed below.

The facility will utilize temporary and permanent stormwater management features and controls, including silt fence, hay bales, drainage ditches, conveyance channels, conveyance piping, berms, and stormwater treatment ponds to ensure all stormwater runoff remains internal to the facility and is adequately being managed. Hay bales may be placed along any future permanent drainage ditches as necessary to control flow and reduce sediment as well as to achieve vegetation. Silt fence will be installed as necessary to reduce sediment load in receiving drainage ditches until more permanent drainage and erosion control measures are established.

All permanent stormwater management features have been sized at a minimum to accommodate peak flows from the appropriate storm events required by the NYSDEC. (See Appendix A, Drainage Report.)

A drainage ditch and/or division berm will be established along the internal haul road to divert flow from this area and other impervious areas within the site into the stormwater management area (See Plate 1). Stormwater flow near the facility entrance is captured by a catch basin system, where it eventually discharges to a vegetated depression on-site (Outfall 002). This outfall will be terminated prior to upgradient excavation activities. Runoff from this area will be controlled by the proposed berms and will infiltrate and/or evaporate. A berm exists along NYS Route 409 to prevent runoff from leaving the property and run-on from entering the property. The stormwater management area will capture on-site runoff, where it will be maintained unless the demand of flow exceeds the capacity of the basin, in which case it will be discharged by an emergency spillway (Outfall 001). The proposed stormwater management area has been designed with NYSDEC provisions to store the water quality volume, channel protection volume, overbank flood protection volume and extreme storm flood protection volume for the proposed drainage area. Calculations for these features were completed by JMT as part of the Drainage Report (Appendix A).



8.0 MONITORING AND SAMPLING DATA

Refer to Section 15.0 of this report for current SPDES Multi-Sector General Permit (GP-0-17-004) sampling requirements. SPDES Permit GP-0-17-004 requires that laboratories conducting sample analysis must be issued a certificate of approval. Inquiries regarding laboratory certification can be submitted to the Laboratory Certification Quality Assurance Group, New York State Health Department Center for Laboratories and Research, Division of Environmental Sciences, The Nelson A. Rockefeller Empire State Plaza, Albany, New York 12201.

Sampling data is unavailable, as there has been no discharge associated with Outfall 001 or Outfall 002, since permit coverage was obtained. The chain of custody along with the analytical laboratory results must be retained with this SWPPP (Appendix J), once sampling has been conducted. Any monitoring waivers that have been claimed must also be kept with this SWPPP.



9.0 NON-STORMWATER DISCHARGES

Outfalls 001 and 002 were evaluated for the presence of non-stormwater. Non-Stormwater Discharge Certification is included as Appendix H. According to facility personnel, there are no non-stormwater discharges (e.g. – fire hydrant flushings, waterline flushings with potable water, irrigation drainage, landscape/lawn watering, routine external building wash-down without detergent, etc.) from the facility.



10.0 COPY OF PERMIT REQUIREMENTS

A copy of the SPDES Multi-Sector General Permit (GP-0-17-004) is included in this SWPPP as Appendix G.



11.0 SIGNATURE AND PLAN REVIEW

Section 2.0 of this report provides a Management Approval signature for this SWPPP. A copy of the SWPPP must be maintained at the facility and must be available for review by the NYSDEC, any other local agency that has an interest in reviewing the SWPPP, the operator of a municipal separate storm sewer system receiving discharge from the site, or to the public upon request (the public would have to provide a written request).

Note: A facility may withhold justifiable portions of the SWPPP from public review that contain trade secrets, confidential commercial information, or critical infrastructure information in accordance with Title 6 NYCRR Part 616.7.

Upon review of the SWPPP, the NYSDEC may require modifications to the SWPPP which need to be addressed within 30 days of receipt of the modification notification.



12.0 SWPPP AMENDMENTS

The SWPPP must be amended:

1. Whenever there is a change in design, construction, operation, or maintenance at the facility which may have an effect on the potential for the discharge of pollutants from the facility; and
2. If inspections, monitoring, or investigations by facility personnel or by Local, State or Federal officials determine the SWPPP is no longer effective in minimizing or eliminating pollutants from the sources identified in the SWPPP.

If Quarterly Visual Monitoring indicates stormwater pollution and structural and/or non-structural BMPs are implemented to prevent recurrence of pollution, the SWPPP must be revised to reflect the changes to BMPs and any other site changes. The Quarterly Visual Monitoring Form is provided as Appendix D. If the results of an inspection, monitoring, or investigation indicate the presence of stormwater pollution or that BMPs are not operating effectively, the Pollution Prevention Team must determine the non-structural or structural BMPs that will be used to prevent future stormwater pollution. Modification to existing BMPs or implementation of additional BMPs must be performed before the next anticipated storm event for items that can be readily resolved. More complicated maintenance or repairs shall be performed as soon as practicable, but not more than 12 weeks after completion of the inspection, monitoring event, or investigation that resulted in the changes. The facility's SWPPP must be updated to include the new BMPs.



13.0 SPECIAL SWPPP REQUIREMENTS

Municipal Separate Storm Sewer Systems

This facility does not discharge to a municipal separate storm sewer system.

EPCRA Section 313 Water Priority Chemicals

Any potential pollutant sources for which the facility has reporting requirements under EPCRA 313 must be identified in the SWPPP. Section 313 of EPCRA requires that reports be filed by owners and operators of facilities that meet all of the following criteria:

- SIC code groups 20 through 39, 10 (except 1011, 1081 and 1094), 12 (except 1241), 4911, 4931, 4939, 4953, 7389, 5169, and 5171;
- Have 10 full time employees (or equivalent of 20,000 hours of work per year) or more; and
- Meet the threshold quantity (manufactured or process greater than 25,000 pounds or provides or use greater than 10,000 pounds of a listed chemical during the course of a calendar year).

The facility SIC is Code 1442; the facility is exempt from EPCRA Section 313 reporting.

Secondary Containment for Bulk Storage & Transfer Areas

The facility does not have petroleum bulk storage requiring registration or secondary containment.



14.0 SALT STORAGE

This facility does not have salt storage piles on-site.



15.0 MONITORING, REPORTING AND RECORD RETENTION

15.1 WEEKLY (REFER TO SECTION 16.3)

15.2 MONTHLY

The Site Manager is responsible for scheduling and assigning a competent person to conduct a monthly inspections. During the monthly inspection, the inspector is to make note of any evidence of a spill, leak, or condition that may result in a spill or leak. Any evidence of a leak or an unexplained loss in inventory is to be brought to the attention of the Site Manager or another member of the Pollution Prevention Team immediately.

In addition, all stormwater management features must be visually inspected monthly. The inspector is to observe catch basins, ponds, earthen dikes for sediment depth, the presence of sheen, integrity of the structure, and erosion. The results of this inspection will be recorded on the Monthly Stormwater Management Feature Inspection Form (Appendix C).

Deficiencies noted during inspections must be addressed in following inspection reports to document the status of and to ensure the effectiveness of the corrective measure implemented.

Inspection and maintenance records are to be maintained for a period of not less than five years from the date of inspection, re-inspection, or maintenance. All records must be kept on-file at the facility or with this SWPPP to ensure suitable access and review by regulatory agencies and plant supervisory personnel.

15.3 QUARTERLY VISUAL EXAMINATION

The following quarterly monitoring requirements are applicable to all facilities covered under the Multi-Sector General Permit, regardless of the facility's sector of industrial activity.

A visual examination of stormwater discharge from each outfall must be conducted quarterly. The visual examination does not require any analytical tests, although it must be made during daylight hours (e.g., normal working hours) in a well-lit area, and it is highly recommended that the same person should collect and examine the discharge for the term of the permit.

The examinations must be made at least once during the following four time frames:



STORMWATER POLLUTION PREVENTION PLAN
It's Greener Now, Inc. – Padua Ridge Gravel Mine Town of Dix, New York

- January 1st – March 31st
- April 1st – June 30th
- July 1st – September 30th
- October 1st – December 31st

The samples must be collected from a discharge that results from a storm event of greater than 0.1 inches that has occurred a minimum of 72 hours from the previous storm of 0.1 inches. The MSGP permit states that, “The 72-hour storm interval is waived if the preceding measurable storm did not result in a stormwater discharge (e.g., a storm events in excess of 0.1 inches may not result in a stormwater discharge at some facilities), or if the owner or operator is able to document that less than a 72 hour interval is representative for local storm events during the sampling period...If no qualifying storm event resulted in runoff from the facility during a monitoring quarter, the owner or operator is excused from visual monitoring for that quarter provided that documentation is included with the monitoring records indicating that no qualifying storm event occurred that resulted in stormwater runoff during that quarter. If a visual examination was performed and the storm event was later determined not to be a measurable (greater than 0.1 inch rainfall) storm event, the visual examination should be included in the SWPPP records.

The sample must be observed for color, clarity, floating solids, settled solids, suspended solids, foam, oil sheen, and any other obvious indicators of stormwater pollution. The sample must also be “sniffed” and odor, or lack thereof, noted.

A Quarterly Visual Monitoring Form has been included in Appendix D. The form and any associated documentation must be signed and certified by a responsible corporate officer or duly authorized representative.

If the results of the visual examination indicate the presence of stormwater pollution (e.g., color, odor, floating solids, settled solids, suspended solids, foam, oil sheen, or other indicators), the Pollution Prevention Team must evaluate the facility to determine the potential sources of stormwater contamination. Once the source(s) of contamination are identified, the Team must determine the non-structural or structural BMPs that will be used to prevent future stormwater pollution. The facility’s SWPPP must be updated to include the new BMPs per section 12.0 SWPPP Amendments of this report. Other required corrective actions the facility must do when the visual examination indicates the presence of pollution are discussed in Section 15.4.



15.4 NUMERIC EFFLUENT LIMITATIONS

This facility does not include any mine dewatering activities, therefore numeric effluent limitations are not applicable.

15.5 SEMI-ANNUAL BENCHMARK MONITORING

The discharge from each outfall must be sampled twice annually during active operations from January 1st to June 30th and from July 1st to December 31st of each year of the general permit term.

Results from the monitoring must be submitted to the NYSDEC using the EPA's electronic DMR reporting system no later than July 28th for the first monitoring period and January 28th for the second monitoring period.

A grab sample must be collected from a discharge that occurs from a storm event of at least 0.1 inches of precipitation that fell at least 72 hours after the last event of 0.1 inches or greater. It must be taken during the first 30 minutes of discharge, and, if this is not possible, during the first 60 minutes. If the stormwater discharge mixes with process and/or non-process water discharge, the person sampling must try to sample the stormwater before it mixes with other water.

The sample must be analyzed for specific pollutants of concern using the analytical methods detailed in the following table.

**Table 2 - Sector J – Benchmark Monitoring Requirements
Sand and Gravel Mining
(SIC 1442, 1446)**

Pollutants of Concern	Analytical Method	Benchmark Monitoring Cut-Off Concentration
Total Suspended Solids (TSS)	EPA 160.2	100 mg/L
Total Nitrogen	EPA 351.2	6 mg/L
Total Recoverable Iron	EPA 200.7	1 mg/L
Total Phosphorous (TP)	EPA 365.3	2 mg/L
Total Recoverable Zinc	EPA 200.8	110 ug/L



All analyses must be conducted by a laboratory that has been issued a certificate of approval.

All sampling, storm, and analytical results must be recorded on the Discharge Monitoring Report Semi-Annual Form using the EPA's electronic DMR reporting system no later than 28 days after the end of the monitoring period (July 28th for the first monitoring period and January 28th for the second monitoring period). In addition, once the electronic report is completed, a copy of the DMR must be printed and kept as part of the SWPPP.

Benchmark concentrations do not constitute direct numeric effluent limitations therefore, a benchmark exceedance itself is not a permit violation; however, if it occurs, the owner or operator must do the following, in accordance with the SPDES MSGP:

1. Inspect the facility for potential sources of stormwater contamination and/or causes of the exceedance to numeric limits;
2. Any sources of contamination that are identified must be addressed by implementation of non-structural and/or structural BMPs to prevent recurrence;
 - a. The implementation must be completed before the next anticipated storm event, if practicable, but not more than 12 weeks after discovery.
 - b. If implementation will take longer than 12 weeks, the owner or operator must submit a proposed schedule for completion of the project and obtain a written approval from the Department.
3. Revise the facility's SWPPP in accordance with Part III.E;
4. If corrective actions at a facility do not result in achieving benchmark monitoring cut-off concentrations and/or numeric effluent limitations, the facility must continue efforts to implement additional BMPs. Failures to undertake and document the review and/or take the necessary corrective actions are violations of the permit. Continued exceedance of benchmark cut-off concentrations and/or effluent limitations guidelines for discharges to impaired waterbodies may identify facilities that would be more appropriately covered under an individual SPDES permit.

15.6 ANNUAL COMPREHENSIVE SITE COMPLIANCE EVALUATION AND INSPECTION

The Comprehensive Site Compliance Evaluation and Inspection must be completed at least once each year after at least three (3) consecutive days of no precipitation to ensure that adequate pollution prevention measures are being implemented and that the measures are protecting the surface water of the State. These evaluations must be conducted by a qualified person; this



person can be either a facility employee or an outside consultant hired by the facility. Qualified individuals must be familiar with the facility's activities, BMPs, SWPPP, and must be able to assess conditions at the facility that could impact stormwater quality and assess effectiveness of the BMPs.

The person doing the inspection must look for water coming into the stormwater retention structure(s) and water discharging from the outfall structure(s). If either type of flow is observed, the inspector must try to determine the source and type of the water and whether or not it is an authorized discharge. An authorized discharge can include a discharge covered by another SPDES permit or an authorized non-stormwater discharge described in Section 9.0 of this report. The SWPPP will need to be modified if a new and allowed non-stormwater discharge is discovered during the comprehensive compliance evaluation.

The Comprehensive Site Compliance Evaluation and Inspection must include all areas where industrial materials or activities are exposed to stormwater and areas where spills and leaks have occurred within the past 5 years. At a minimum, the following should be evaluated:

- Industrial materials, residue or trash on the ground that could contaminate or be washed away in stormwater;
- Leaks or spills from industrial equipment, drums, barrels, tanks or similar containers;
- Unauthorized non-stormwater discharges or allowable non-stormwater discharges that are not certified;
- Off-site tracking of industrial materials or sediment where vehicles enter or exit the site;
- Tracking or blowing of raw, final or waste materials from exposed areas to areas of no exposure;
- Evidence of or the potential for, pollutants entering the drainage system;
- Results of visual and analytical monitoring done during the year;
- The adequacy of both structural and non-structural BMPs; and
- Discharge locations must be observed to see if BMPs are effective in preventing significant impacts to receiving waters.

If the results of the evaluation and inspection indicate the presence of non-stormwater discharge(s) that are not allowed, the Pollution Prevention Team must evaluate the facility to determine the potential sources of the discharge(s). Once the source(s) of non-stormwater discharge(s) are identified, the Team must determine the non-structural or structural BMPs that



will be used to eliminate the non-stormwater discharges. The facility's SWPPP must be updated to include the new BMPs per section 12.0 SWPPP Amendments of this report. If the source cannot be easily eliminated, the facility or its agent must notify the NYSDEC. Further action may include permitting the discharge under an individual industrial SPDES permit or connection to the sanitary sewer system.

As a result of the Comprehensive Site Compliance Evaluation and Inspection, IGN shall, if necessary, amend the SWPPP within 2 weeks of the inspection and necessary changes shall be implemented within twelve weeks. Appendix B provides a blank Annual Comprehensive Site Compliance Evaluation and Inspection Report form that can be used to document annual evaluation results. A copy of the completed report must be maintained with the SWPPP for at least 5 years from the date of the report. When the Annual Comprehensive Site Compliance Evaluation and Inspection overlaps with a monthly routine visual inspection, the Annual Comprehensive Site Compliance Evaluation and Inspection may be used as one of the routine inspections.

15.7 ANNUAL CERTIFICATION REPORT

The Annual Certification Report (Appendix F) must be completed and submitted to the NYSDEC by January 28th in every year of the permit term. These reports must be submitted electronically using the NYSDEC's ACR, located on their website: <http://www.dec.ny.gov/>. Paper submissions of the report will be accepted until December 21, 2020 and must be mailed to:

Stormwater Compliance Coordinator
NYSDEC, Bureau of Water Permits
625 Broadway
Albany, New York 12233-3505



16.0 SECTOR SPECIFIC PERMIT REQUIREMENTS

This facility must comply with the additional requirements of GP-0-17-004 that apply to the specific industrial activity located at this facility. Sections 15.4 and 15.5 of this report provide a summary of numeric effluent limitations and semi-annual benchmark monitoring requirements that are sector specific permit requirements for the facility.

16.1 NON-STORMWATER DISCHARGES

The following additional non-stormwater discharges are not covered under this permit: material wash water, floor and equipment washing, vehicle and equipment maintenance fluids.

The discharge of clean water used for dust suppression on roadways may be allowed under the Multi-Sector General Permit if application rates are limited and runoff is reduced to the greatest extent practicable.

16.2 QUARTERLY INSPECTIONS

All BMPs at the facility must be inspected quarterly. This inspection must include: material handling areas, above ground storage tanks, hoppers or silos, dust collection/containment areas, truck wash and equipment cleaning areas, assessment of the integrity of stormwater discharge diversions, conveyance systems, sediment control and collection systems and containment structures; inspections to determine if soil erosion has occurred at, or as a result of vegetative BMPs, serrated slopes, and/or benched slopes; inspections of material handling and storage areas and other potential sources of pollution for evidence of actual or potential discharges of contaminated stormwater.

This quarterly inspection requirement will be satisfied by the Monthly Stormwater Management Feature Inspection Report Form (Appendix C).

16.3 WEEKLY INSPECTIONS

To ensure the stability and effectiveness of all protective measures and practices during construction, or when soil disturbance is ongoing, all erosion control measures employed will be inspected by a *qualified person* every 7 calendar days and within 24 hours of any storm event



producing 0.5 inches of precipitation or more. Erosion control measures will be repaired and maintained as necessary by the facility.

Within one (1) business day of the completion of an inspection, the *qualified person* shall notify the *owner or operator* and appropriate contractor of any corrective actions that need to be taken. The *owner or operator* shall begin implementing the corrective actions within one (1) business day of this notification and shall complete the corrective actions within seven (7) calendar days unless otherwise notified by the *Department*.

The inspections will be recorded on the Inspection Form in Appendix K. Specifically, each inspection shall record the following information:

- Date and time of inspection;
- Name and title of person(s) performing inspection;
- A description of the weather and soil conditions (e.g. dry, wet, saturated) at the time of the inspection;
- A description of the condition of the runoff at all points of discharge from the construction site. This shall include identification of any discharges of sediment from the construction site. Include discharges from conveyance systems (i.e. pipes, culverts, ditches, etc.) and overland flow;
- A description of the condition of all natural surface waterbodies located within, or immediately adjacent to, the property boundaries of the construction site which receive runoff from disturbed areas. This shall include identification of any discharges of sediment to the surface waterbody;
- Identification of all erosion and sediment control practices and pollution prevention measures that need repair or maintenance;
- Identification of all erosion and sediment control practices and pollution prevention measures that were not installed properly or are not functioning as designed and need to be reinstalled or replaced;



STORMWATER POLLUTION PREVENTION PLAN
It's Greener Now, Inc. – Padua Ridge Gravel Mine Town of Dix, New York

- Description and sketch of areas with active soil disturbance activity, areas that have been disturbed but are inactive at the time of the inspection, and areas that have been stabilized (temporary and/or final) since the last inspection;
- Current phase of construction of all post-construction stormwater management practices and identification of all construction that is not in conformance with the SWPPP, its addendum and technical standards;
- Corrective action(s) that must be taken to install, repair, replace or maintain erosion and sediment control practices and pollution prevention measures; and to correct deficiencies identified with the construction of the post-construction stormwater management practice(s);
- Identification and status of all corrective actions that were required by previous inspection; and
- Digital photographs, with date stamp, that clearly show the condition of all practices that have been identified as needing corrective actions. The qualified inspector shall attach paper color copies of the digital photographs to the inspection report being maintained onsite within seven (7) calendar days of the date of the inspection. The qualified inspector shall also take digital photographs, with date stamp, that clearly show the condition of the practice(s) after the corrective action has been completed. The qualified inspector shall attach paper color copies of the digital photographs to the inspection report that documents the completion of the corrective action work within seven (7) calendar days of that inspection.

Note, where soil disturbance activities have been temporarily suspended (e.g. winter shutdown) and temporary stabilization has been applied to all disturbed areas or if runoff is unlikely due to winter conditions (e.g., site is covered with snow, ice, or the ground is frozen), the qualified person shall conduct a site inspection at least once every thirty (30) calendar days.



FIGURE 1

SITE LOCATION MAP

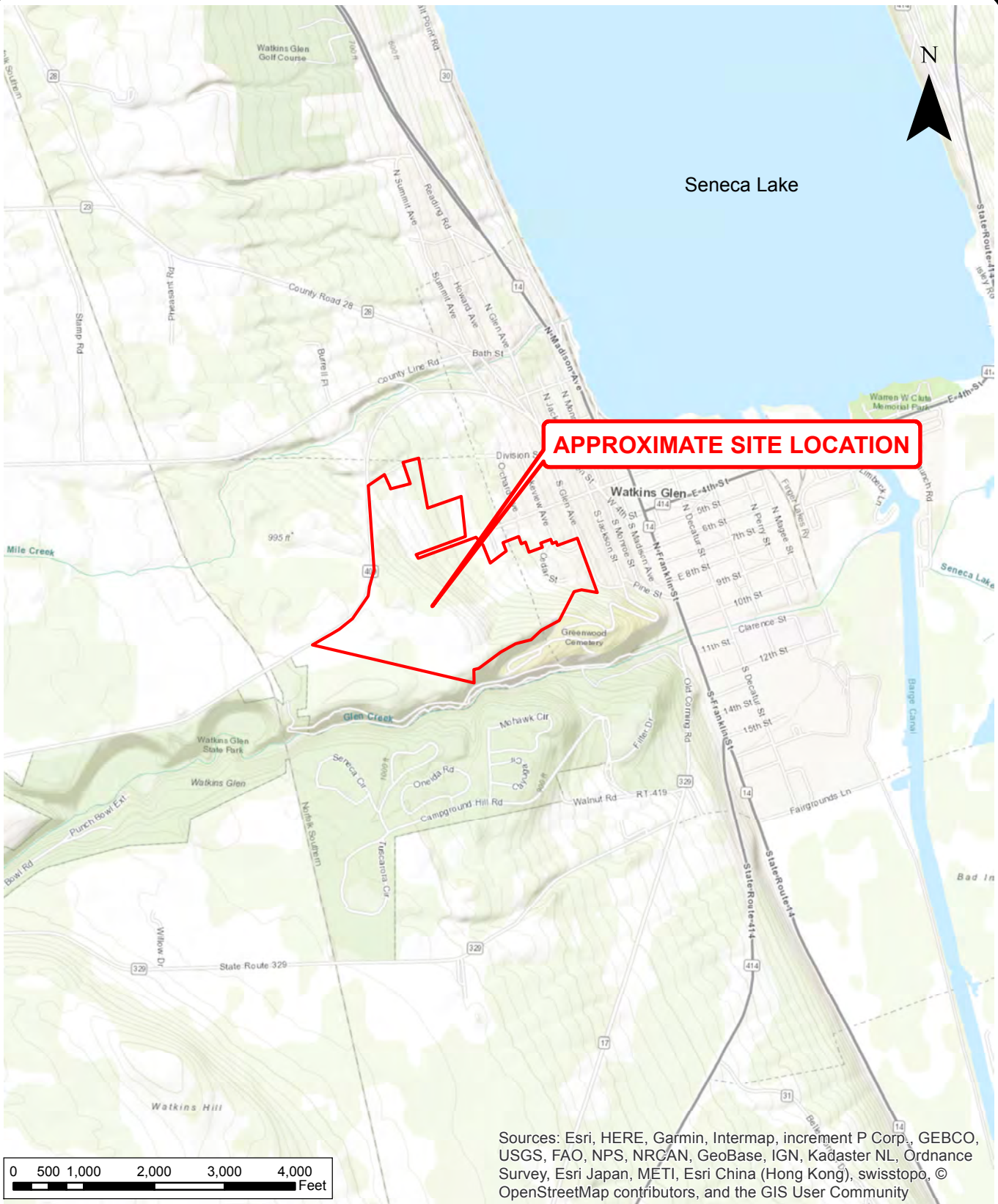

19 British American Blvd., Latham, New York 12110
 P: (518) 782-0882 F: (518) 782-0973 www.jmt.com

SITE LOCATION MAP
IT'S GREENER NOW, INC.
 PADUA RIDGE GRAVEL MINE

TOWN OF DIX

SCHUYLER CO., NY



STORMWATER POLLUTION PREVENTION PLAN
It's Greener Now, Inc. – Padua Ridge Gravel Mine Town of Dix, New York

PLATE 1

SITE PLAN

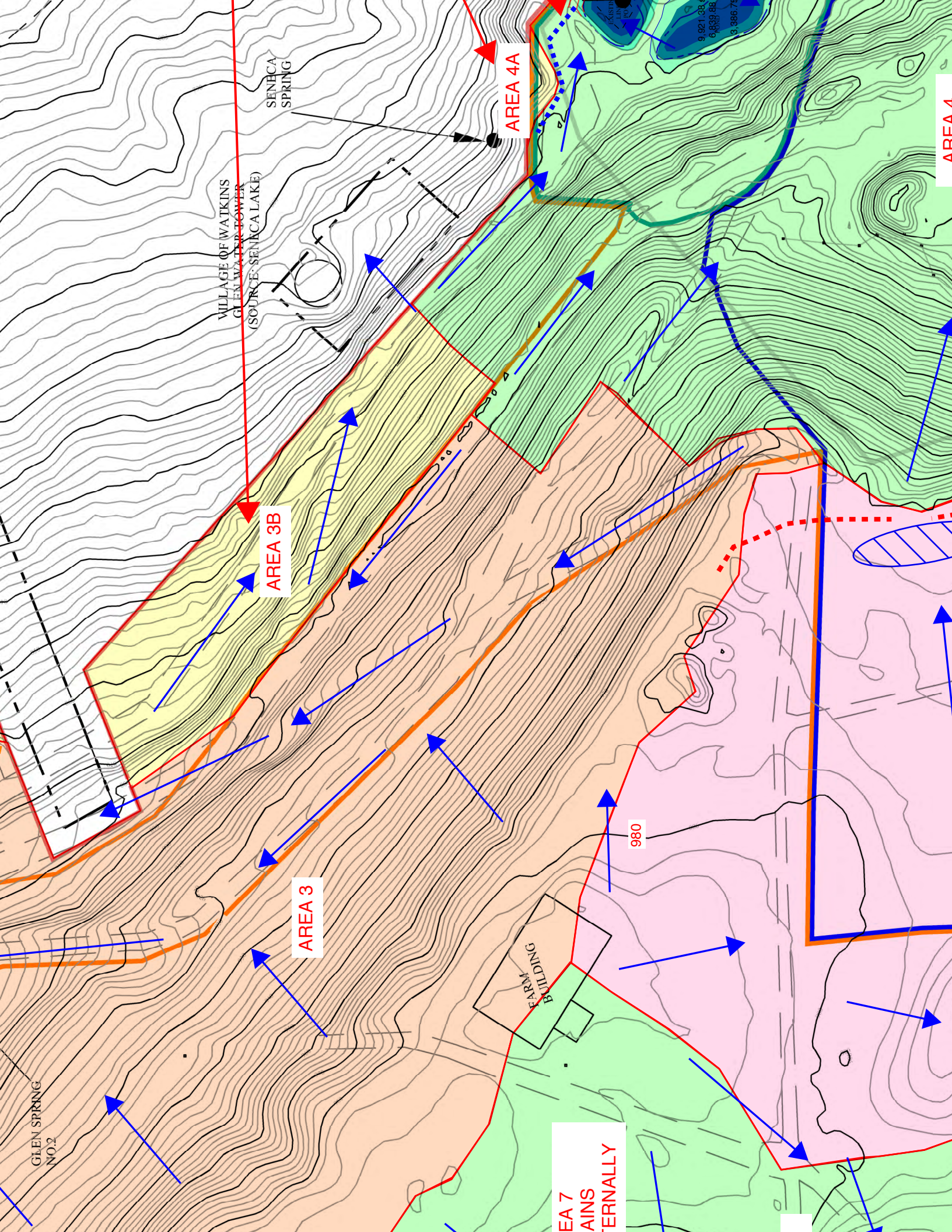

VILLAGE OF WATKINS
GLEN WATER TOWER
(SOURCE: SENECA LAKE)

AREA 3B

AREA 3

AREA 4A

AREA 4

FARM BUILDING

980

9,921.38
6,839.88
3,366.72

GLEN SPRING
NO.2

EA 7
AINS
ERNALLY



APPENDIX A

DRAINAGE REPORT



DRAINAGE REPORT

**IT'S GREENER NOW, INC.
PADUA RIDGE GRAVEL MINE**

**TOWN OF DIX
SCHUYLER COUNTY, NEW YORK**

Prepared for:

It's Greener Now, Inc.
3362 Route 409
Watkins Glen, New York 14891

Prepared by:

JMT of New York, Inc.
19 British American Boulevard
Latham, New York 12110

Submitted: June 2022

Project No: 16-S0157N-001





TABLE OF CONTENTS

1.0	INTRODUCTION.....	1
2.0	DRAINAGE AREAS	1
2.1	EXISTING CONDITION	1
2.2	PRE- AND POST- RECLAMATION CONDITION	3
3.0	DRAINAGE AREAS AND SOILS.....	4
4.0	DRAINAGE ANALYSIS	6
4.1	INFILTRATION AREAS	6
4.2	POND DESIGN STRATEGY	6
4.2.1	Pond Volumes and Discharge Rates.....	8
4.3	DRAINAGE EASEMENT.....	9

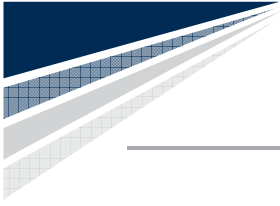

FIGURES

- FIGURE 1 EXISTING CONDITIONS DRAINAGE AREAS**
- FIGURE 2 PRE- AND POST-RECLAMATION DRAINAGE AREAS**
- FIGURE 3 SOIL TYPES AND AERIAL OVERLAY**
- FIGURE 4 DOWNSLOPE CONTRIBUTING AREAS**

APPENDICES

- APPENDIX A SOILS REPORT**
- APPENDIX B SOIL TYPE AND GROUND COVER TABLE**
- APPENDIX C NOAA ATLAS 14 PRECIPITATION DATA**
- APPENDIX D EXISTING CONDITION - TEMPORARY SEDIMENT BASIN DESIGN DATA SHEET
AND DISCHARGE STRUCTURE**
- APPENDIX E PRE-RECLAMATION CONDITION - TEMPORARY SEDIMENT BASIN DESIGN DATA SHEET
AND DISCHARGE STRUCTURE**
- APPENDIX F PRE-RECLAMATION CONDITION POND ANTI-SEEP COLLAR WORKSHEET AND
OUTLET PROTECTION SIZING**
- APPENDIX G HYDROCAD MODEL REPORTS**

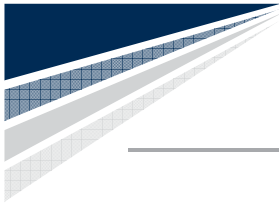

1.0 INTRODUCTION

This drainage report has been prepared for It's Greener Now, Inc.'s Padua Ridge Gravel Mine facility in Watkins Glen, New York. The report is intended to support the application for modification of the Mined Land Use Permit and respond to comments from the Department of Environmental Conservation regarding previous submittals by the owner/applicant.

2.0 DRAINAGE AREAS

This drainage report evaluates individual drainage areas within the proposed life-of-mine (LOM) area under the conditions that presently exist at the facility, the conditions that will potentially exist immediately prior to reclamation, and the conditions that will exist after reclamation is complete.

2.1 EXISTING CONDITION

Presently there are areas within the LOM boundary that drain internally, and areas that drain offsite (see Figure 1, Existing Conditions Drainage Areas). Uphill areas outside the LOM boundary to the east and south drain towards the LOM. These areas have been included in the runoff calculations. The areas that lie in the northern part of the facility (Areas 1, 2 and 3) are largely undisturbed and have forest or meadow land cover except where driveways and buildings have been established. The areas that lie in the southern portion of the facility are mostly open meadow used for grazing, and a section that remains forest covered along the southern LOM boundary.

Runoff from Areas 1 and 3 drains to level areas that lie at the top of the lower crest of Padua Ridge, where water is captured by topography and or soil berms. The eastern most parts of Areas 1 and 3 (Areas 1A and 3A) are topographically below the existing drainage capture features. Since runoff from these areas, as well as Areas 1B and 3B, cannot be captured, the existing natural vegetation will be maintained indefinitely or until mining changes the topography allowing these areas to be captured. Higher elevation areas of above Area 1 outside the LOM boundary (Area 1C, 1D and 1E) presently drain towards the LOM and have therefore been included in the drainage analysis of Area 1. The topography of a small part of this area (Area 3C) within the LOM boundary directs runoff to the roadside ditch along NYS Route 409. Since this

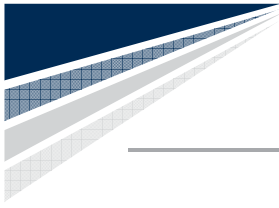

area is presently not disturbed by mining activity and does not contribute runoff to a control feature, it has not been included in the existing drainage analysis.

Area 2 is internally draining to an existing open water feature within the LOM Boundary. Since the area does not presently contribute to a specific control feature it has not been included in the existing condition drainage analysis.

Area 4 is the active mining area. At this time there are three ponds providing storage and treatment for stormwater runoff within the active mining area. Areas 4A, 4B, and 4C within the LOM boundary lie below existing drainage capture features. Since runoff from these areas cannot be captured, the existing natural vegetation will be maintained until mining changes the topography allowing these areas to be captured. Area 4D lies outside the LOM boundary but contributes runoff to the mining area.

Area 5 lies immediately above the active mine area. This area is relatively level, mostly open meadow, with approximately 3 acres of forest along the southern LOM boundary. Area 5 receives runoff from the area south of the facility (identified in the analysis as the Upland area). Soil conditions allow runoff from both within Area 5 and the Upland area to naturally infiltrate. Natural topography and diversion berms or ditches prevent runoff from entering the active mine area.

The natural topography of Area 6 at the southwest corner of the facility presently directs runoff to the roadside ditch along NYS Route 409. This area has meadow land cover. Since the area is undisturbed by mining activity in the existing condition it is not included in the drainage analysis.

Area 7 is a low area along the western boundary of the facility, consisting of grazed meadow land. This area is internally draining to an existing open water feature within the LOM boundary. Since the area does not presently contribute to a specific control feature it has not been included in the existing condition drainage analysis.

The area east and below the LOM boundary that contributes runoff to the drainage easement (designated as the Downslope area) has been included in the existing condition analysis to allow comparison to the pre-reclamation condition. Runoff from Areas 1A, 1B, 3A, 3B and 4B, which are currently uncaptured, is included in the Downslope area analysis for the existing condition.

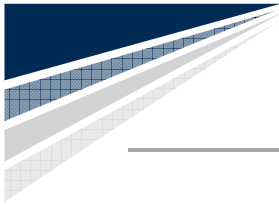

A USDA/NRCS Custom Soil Resource Survey Report (Appendix A) is attached for the subject area. All of the area within the LOM boundary, except the lowest sections of Areas 3A and 3B are Hydrologic Soil Group (HSG) A or B. All of Areas 4, 5, 6 and 7 are HSG A. Area 1 and the northern-most part of Area 3 are HSG B. Small portions of Area 3A and 3B, and the majority of the Downslope area (outside the LOM) are HSG D. The breakdown of soil types are provided in the table below.

2.2 PRE- AND POST- RECLAMATION CONDITION

A drainage analysis was performed for the facility representing two future conditions, one immediately before reclamation, when the extent of disturbed soil is potentially greatest, and one after reclamation of the entire site has been completed. At this future point in time, it is assumed that runoff from all areas uphill of the LOM will have been diverted except Area 1E and Area 4D.

The areas that are uncaptured in the existing condition, except for Areas 1A and 3A, will have been mined or otherwise graded so that runoff is captured by controls within the LOM. As in the existing condition, Area 2 continues to be internally draining in the pre-reclamation and post-reclamation condition and is therefore left out of the drainage analysis.

In the pre- and post-reclamation condition, much of Area 3 that previously drained to the north will be within the capture and control of Area 4. The remaining part of Area 3 north of the Area 4 subdrainage area, and Areas 1 and 2 remain unmined and in the same condition as in the existing condition model.

All of Areas 3B, 4A, 4B and 4C that are uncaptured in the existing condition will also be within the capture and control of Area 4. As a result of mining in the western direction, Areas 5, 6 and 7 will be incorporated into Area 4. It is further assumed that any runoff from the Upland area to the south of the facility will infiltrate outside the LOM or be diverted. Areas 3A and 3B will still be uncaptured in the future pre- and post-reclamation condition, contributing runoff to the Downslope area that is captured by the drainage easement, and the natural vegetation cover in these two areas will be maintained.

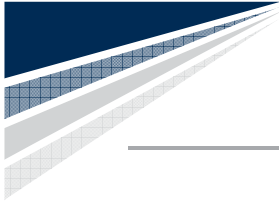

The difference between the pre- and post-reclamation conditions is the ground cover in Area 4 and the absence of an outfall structure in the post-reclamation condition. In the post-reclamation condition Area 4 is assumed to be fully vegetated.

3.0 DRAINAGE AREAS AND SOILS

A tabulated summary of sub-drainage areas in the existing and the pre- and post-reclamation area is provided in the following table. For each condition the table includes a column that sums the area within the life-of-mine boundary. The deviation from the total LOM area in the modeled drainage area total is due to the off-site upslope contributing areas.

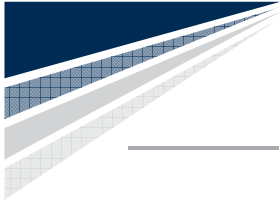

Area Summary Table

		Existing		LOM	Pre/Post-Reclamatic		LOM
		sq ft	acres	acres	sq ft	acres	acres
Area 1		255481	5.87	5.87	265195	6.09	6.09
Area 1A	Uncaptured Downslope	52259	1.20	1.20	52259	1.20	1.20
Area 1B	Uncaptured Downslope	10055	0.23	0.23			
Area 1C	Off-Site Upslope	17590	0.40				
Area 1D	Off-Site Upslope	5578	0.13				
Area 1E	Off-Site Upslope	14077	0.32		14077	0.32	
Area 2	Drains Internally	55334	1.27	1.27	55334	1.27	1.27
Area 2A	Off-Site Upslope	14279	0.33				
Area 3		589574	13.53	13.53	240062	5.51	5.51
Area 3A	Uncaptured Downslope	24856	0.57	0.57	24856	0.57	0.57
Area 3B	Uncaptured Downslope	82920	1.90	1.90			
Area 3C	Uncaptured Upslope	5486	0.13	0.13			
Area 4		794273	18.23	18.23	2641679	60.64	60.64
Area 4A	Uncaptured Downslope	2185	0.05	0.05			
Area 4B	Uncaptured Downslope	7875	0.18	0.18			
Area 4C	Off-Site Upslope	52402	1.20	1.20			
Area 4D	Off-Site Upslope	8050	0.18				
Area 5		951774	21.85	21.85			
Area 6	Uncaptured Upslope	89501	2.05	2.05			
Area 7	Drains Internally	305282	7.01	7.01			
	On-Site Subtotal		76.65	75.28		75.61	75.28
Upland		602677	13.84				
Downslope		1137566	26.11		1137566	26.11	
	Total		116.60			101.72	

The attached Soil Type and Cover Table (Appendix B) presents the breakdown of the sub-drainage areas by hydrologic soil group and cover types. In areas of active mining and areas where there are buildings and driveways, ground cover is treated as disturbed with higher CN. Elsewhere the cover type is inferred by reference to aerial photogrammetry.

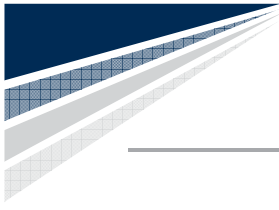

4.0 DRAINAGE ANALYSIS

The drainage analysis was conducted with HydroCAD software. HydroCAD model reports are attached for the existing condition (10-year and 25-year storm events), the pre-remediation condition (10-year and 25-year storm events), and the post-remediation condition (10-year storm event). Precipitation data was obtained from NOAA Atlas 14 for the Watkins Glen area (see Appendix C). Drainage areas were modeled with the soil groups and ground covers presented in the table above.

4.1 INFILTRATION AREAS

The attached NRCS/USDA Soil Report (Appendix A) provides a transmissivity range for each soil type. The infiltration areas at the low points in Areas 1 and 3 are located in Valois gravelly silt loam having a transmissivity range of 0.57 to 1.98 inches per hour. The model conservatively represents these areas as having a percolation rate of 0.5 inch per hour. Under the soil conditions of the contributing areas and the infiltration areas, the accumulation of standing water during a 10-year event is negligible. It is therefore not necessary to establish ponds with outfall structures for these drainage areas. To the extent that runoff does accumulate, it can be retained in these areas with grading or soil berms if necessary.

Similarly, the soils in Area 5 of the existing condition are located in Howard gravelly loam having a transmissivity range of 0.57 to 5.95 inches per hour. Even with the assumption that the Upland area to the south of the facility contributes runoff to Area 5, the soil conditions are such that the accumulation of standing water in the level area above the active mining area is negligible during a 10-year storm. It is therefore not necessary to establish ponds with outfall structures for these drainage areas. To the extent that runoff does accumulate, it can be retained in these areas with grading or soil berms if necessary.

4.2 POND DESIGN STRATEGY

Temporary Sediment Basin Design Data Sheets are attached for the active mine area, Area 4, for the existing condition and the pre-reclamation condition (See Appendices D and E). The data sheets were used to determine preliminary pond sizing which was then refined through modeling.

For the existing condition, the model represents three ponds in the active mine area as indicated by aerial photogrammetry and topography. The three ponds are designated 4A, 4B and 4C in the

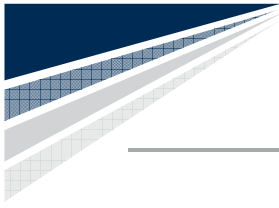

analysis. Pond 4C will be enlarged to provide the capacity required for sediment basins by the New York State Standards and Specifications for Erosion and Sediment Control. A formal discharge control structure will also be constructed to obtain the detention requirements of the Standards and Specifications.

For the pre-reclamation condition which represents the worst case (highest volume and peak rate of runoff) from the fully developed mine site, a single pond has been sized to meet the detention requirements of the Standards and Specifications that will potentially exist immediately prior to reclamation of the mine site. Using a contributing area of 60.3 acres, the resulting design provides greater capacity than will actually be required because portions of the active mine area will be reclaimed as work progresses so that the area of disturbance never exceeds 50 acres.

The post-reclamation model represents the site as having been returned to a fully vegetated condition. With the soil conditions given in the soils report, the modeling indicates that a flow restricting outfall structure will not be necessary to control runoff from the 10-year storm. The model shows that the flows generated by the 10-year storm can easily be accommodated by a grass lined channel. After the contributing area has been re-vegetated during reclamation of the mine, the sediment basin will be pumped out, embankment reduced to native grade, and the outlet structure will be removed.

The outlet control structure for the three relevant conditions are presented in the following table.

Condition	Outlet Structure
Existing Primary Auxilliary	Sharp Crested Rectangular Weir 3.5 feet wide @ el. 834.8 6 feet wide @ el. 835.3 4 @ 2-inch diameter low flow orifice 24-inch Diameter Culvert
Pre-Reclamation Primary Auxilliary	Sharp Crested Rectangular Weir 2 @ 3.5 feet wide @ el. 838.2 20 ft Long @ el. 838.5 4 @ 3-inch diameter low flow orifice 24-inch Diameter Culvert
Post-Reclamation	Grass Lined Channel invert @ el. 832.0

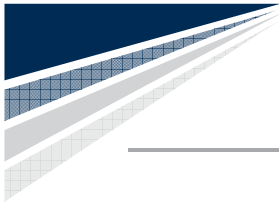

For the existing condition and the pre-reclamation condition, all of the discharge from the 10-year storm is conveyed through the primary discharge structure. For the existing condition Pond 4C provides approximately 1.1 feet of freeboard with the embankment at el. 836. For the pre-reclamation the retention pond provides approximately 1.7 feet of freeboard with the embankment at el. 840.

Calculation sheets are included in Appendix F for the design of the anti-seep collars and outlet protection under the pre-reclamation hydraulic conditions.

4.2.1 Pond Volumes and Discharge Rates

The mine operator will gradually expand the ponds as mining provides more space, and the outfall structure will be improved as needed to maintain the sediment storage and detention requirements dictated by contributing area and soil disturbance in the expanding mine.

Condition	10-yr Storm		Sediment Storage		Dewatering Volume	
	Inflow cfs	Outflow cfs	Required cu-ft	Provided cu-ft	Required cu-ft	Provided cu-ft
Existing	56.46	1.19	18,420	19,727	66,312	66,918
Pre-Reclamation	81.16	3.44	60,000	61,614	216,000	219,495
Post-Reclamation	0.18	0.18	NA	NA	NA	NA

The required sediment storage volume for the existing condition pond system is provided by storage capacity in all three ponds as tabulated below. The dewatering volume required is provided in the last pond, Pond 4C.

Existing Condition Sediment Storage			
Pond	Top of Sediment Storage El.	Storage Volume cu-ft	Surface Area sq-ft
Pond 4A	844	2114	2500
Pond 4B	838	5003	6800
Pond 4C	832	12610	16000
		19727	25300

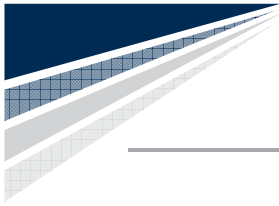

The required storage volume and dewatering volume for the pre-reclamation condition is provided in the future single pond.

4.3 DRAINAGE EASEMENT

The Downslope drainage area generates far more runoff to the drainage easement channel than the mine site because of the type of soil present in the downslope area, and because the pond discharges are limited by the outlet control structures for the existing and pre-reclamation condition.

The attached Downslope Contributing Areas figure (Figure 4) shows how the various soil types and covers are represented in the HydroCAD model (Appendix G). The results of the modeling of the Downslope Area are summarized below.

10-Year Storm	Downslope Runoff cfs	Sediment Basin Discharge cfs	Drainage Easement Flow cfs
Existing Condition	33.86	1.10	34.96
Pre-Reclamation Condition	35.51	3.79	39.30
Post-Reclamation Condition	35.51	0.14	35.65

The post-reclamation condition most closely represents the conditions that would have existed before any mining occurred at the site. With the detention controls specified, the flow in the drainage easement increases by approximately 11% under the worst-case conditions.



FIGURES

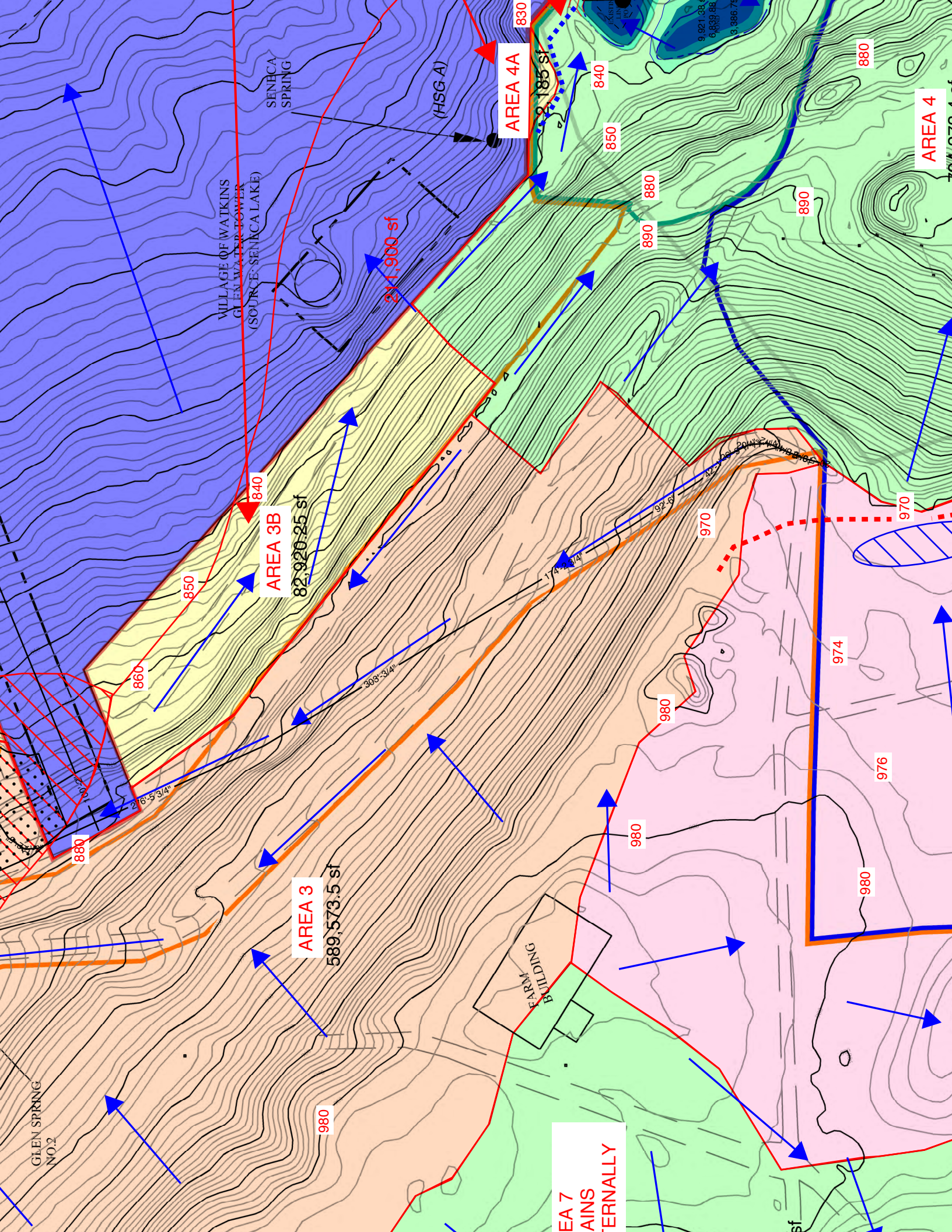

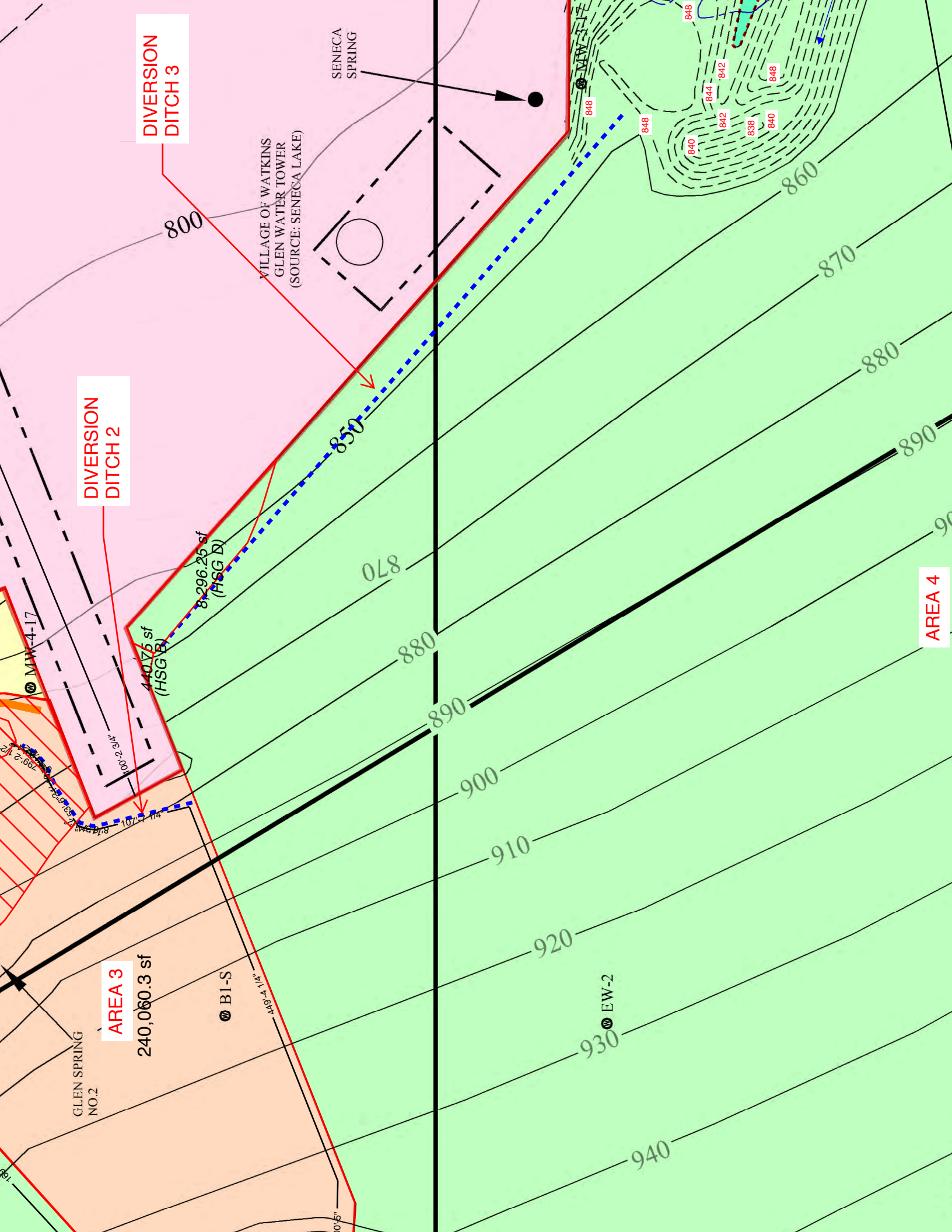

DIVERSION
DITCH 3

DIVERSION
DITCH 2

AREA 3
240,060.3 sf

AREA 4

VILLAGE OF WATKINS
GLEN WATER TOWER
(SOURCE: SENECA LAKE)

SENECA
SPRING

NEW LIFE

MW-4-17

B1-S

EW-2

GLEN SPRING
NO.2

440.76 sf
(HSG B)

8,296.26 sf
(HSG D)

449.4 1/4°

10°51'

800

850

870

880

890

900

910

920

930

940

860

870

880

890

900

848

848

844

842

848

840

844

842

838

840

860

870

880

890

900



VILLAGE OF WATKINS
GLEN WATER TOWER
(SOURCE: SENECA LAKE)



SENECA
SPRING

HSD
HSG A

FARM
BUILDING

GLEN SPRING
NO.2

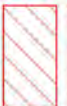
HSG A

- HSG D 
- HSG B 
- HSG A 
- Traffic Area 



D CONDITION



EXISTING CONDITION

Soil Type	Reclaimed Condition	Existing Condition
HSG D	877,297	884,675
HSG B	198,522	208,733
HSG A	138,897	224,307
	1,214,716	1,317,715
Traffic Area		
	31,392	31,392
	2,475	2,475
	33,867	6,681
		40,548



APPENDIX A

SOILS REPORT



United States
Department of
Agriculture

NRCS

Natural
Resources
Conservation
Service

A product of the National
Cooperative Soil Survey,
a joint effort of the United
States Department of
Agriculture and other
Federal agencies, State
agencies including the
Agricultural Experiment
Stations, and local
participants

Custom Soil Resource Report for **Schuyler County, New York**



Preface

Soil surveys contain information that affects land use planning in survey areas. They highlight soil limitations that affect various land uses and provide information about the properties of the soils in the survey areas. Soil surveys are designed for many different users, including farmers, ranchers, foresters, agronomists, urban planners, community officials, engineers, developers, builders, and home buyers. Also, conservationists, teachers, students, and specialists in recreation, waste disposal, and pollution control can use the surveys to help them understand, protect, or enhance the environment.

Various land use regulations of Federal, State, and local governments may impose special restrictions on land use or land treatment. Soil surveys identify soil properties that are used in making various land use or land treatment decisions. The information is intended to help the land users identify and reduce the effects of soil limitations on various land uses. The landowner or user is responsible for identifying and complying with existing laws and regulations.

Although soil survey information can be used for general farm, local, and wider area planning, onsite investigation is needed to supplement this information in some cases. Examples include soil quality assessments (<http://www.nrcs.usda.gov/wps/portal/nrcs/main/soils/health/>) and certain conservation and engineering applications. For more detailed information, contact your local USDA Service Center (<https://offices.sc.egov.usda.gov/locator/app?agency=nrcs>) or your NRCS State Soil Scientist (http://www.nrcs.usda.gov/wps/portal/nrcs/detail/soils/contactus/?cid=nrcs142p2_053951).

Great differences in soil properties can occur within short distances. Some soils are seasonally wet or subject to flooding. Some are too unstable to be used as a foundation for buildings or roads. Clayey or wet soils are poorly suited to use as septic tank absorption fields. A high water table makes a soil poorly suited to basements or underground installations.

The National Cooperative Soil Survey is a joint effort of the United States Department of Agriculture and other Federal agencies, State agencies including the Agricultural Experiment Stations, and local agencies. The Natural Resources Conservation Service (NRCS) has leadership for the Federal part of the National Cooperative Soil Survey.

Information about soils is updated periodically. Updated information is available through the NRCS Web Soil Survey, the site for official soil survey information.

The U.S. Department of Agriculture (USDA) prohibits discrimination in all its programs and activities on the basis of race, color, national origin, age, disability, and where applicable, sex, marital status, familial status, parental status, religion, sexual orientation, genetic information, political beliefs, reprisal, or because all or a part of an individual's income is derived from any public assistance program. (Not all prohibited bases apply to all programs.) Persons with disabilities who require

alternative means for communication of program information (Braille, large print, audiotape, etc.) should contact USDA's TARGET Center at (202) 720-2600 (voice and TDD). To file a complaint of discrimination, write to USDA, Director, Office of Civil Rights, 1400 Independence Avenue, S.W., Washington, D.C. 20250-9410 or call (800) 795-3272 (voice) or (202) 720-6382 (TDD). USDA is an equal opportunity provider and employer.

Contents

Preface	2
How Soil Surveys Are Made	5
Soil Map	8
Soil Map.....	9
Legend.....	10
Map Unit Legend.....	11
Map Unit Descriptions.....	11
Schuyler County, New York.....	14
AuC—Aurora channery silt loam, 8 to 15 percent slopes.....	14
HrB—Howard gravelly loam, 3 to 8 percent slopes.....	15
HrC—Howard gravelly loam, 8 to 15 percent slopes.....	16
HrCK—Howard gravelly loam, rolling.....	17
HSD—Howard soils, moderately steep.....	19
ROF—Rock outcrop-Arnot complex, 25 to 70 percent slopes.....	20
ScC3—Schoharie silty clay loam, 8 to 15 percent slopes.....	21
ShC3—Schoharie variant silty clay loam, 8 to 15 percent slopes, severely eroded.....	23
VaC—Valois gravelly silt loam, 8 to 15 percent slopes.....	24
VHF—Valois and Howard soils, very steep.....	26
W—Water.....	28
References	29

How Soil Surveys Are Made

Soil surveys are made to provide information about the soils and miscellaneous areas in a specific area. They include a description of the soils and miscellaneous areas and their location on the landscape and tables that show soil properties and limitations affecting various uses. Soil scientists observed the steepness, length, and shape of the slopes; the general pattern of drainage; the kinds of crops and native plants; and the kinds of bedrock. They observed and described many soil profiles. A soil profile is the sequence of natural layers, or horizons, in a soil. The profile extends from the surface down into the unconsolidated material in which the soil formed or from the surface down to bedrock. The unconsolidated material is devoid of roots and other living organisms and has not been changed by other biological activity.

Currently, soils are mapped according to the boundaries of major land resource areas (MLRAs). MLRAs are geographically associated land resource units that share common characteristics related to physiography, geology, climate, water resources, soils, biological resources, and land uses (USDA, 2006). Soil survey areas typically consist of parts of one or more MLRA.

The soils and miscellaneous areas in a survey area occur in an orderly pattern that is related to the geology, landforms, relief, climate, and natural vegetation of the area. Each kind of soil and miscellaneous area is associated with a particular kind of landform or with a segment of the landform. By observing the soils and miscellaneous areas in the survey area and relating their position to specific segments of the landform, a soil scientist develops a concept, or model, of how they were formed. Thus, during mapping, this model enables the soil scientist to predict with a considerable degree of accuracy the kind of soil or miscellaneous area at a specific location on the landscape.

Commonly, individual soils on the landscape merge into one another as their characteristics gradually change. To construct an accurate soil map, however, soil scientists must determine the boundaries between the soils. They can observe only a limited number of soil profiles. Nevertheless, these observations, supplemented by an understanding of the soil-vegetation-landscape relationship, are sufficient to verify predictions of the kinds of soil in an area and to determine the boundaries.

Soil scientists recorded the characteristics of the soil profiles that they studied. They noted soil color, texture, size and shape of soil aggregates, kind and amount of rock fragments, distribution of plant roots, reaction, and other features that enable them to identify soils. After describing the soils in the survey area and determining their properties, the soil scientists assigned the soils to taxonomic classes (units). Taxonomic classes are concepts. Each taxonomic class has a set of soil characteristics with precisely defined limits. The classes are used as a basis for comparison to classify soils systematically. Soil taxonomy, the system of taxonomic classification used in the United States, is based mainly on the kind and character of soil properties and the arrangement of horizons within the profile. After the soil

Custom Soil Resource Report

scientists classified and named the soils in the survey area, they compared the individual soils with similar soils in the same taxonomic class in other areas so that they could confirm data and assemble additional data based on experience and research.

The objective of soil mapping is not to delineate pure map unit components; the objective is to separate the landscape into landforms or landform segments that have similar use and management requirements. Each map unit is defined by a unique combination of soil components and/or miscellaneous areas in predictable proportions. Some components may be highly contrasting to the other components of the map unit. The presence of minor components in a map unit in no way diminishes the usefulness or accuracy of the data. The delineation of such landforms and landform segments on the map provides sufficient information for the development of resource plans. If intensive use of small areas is planned, onsite investigation is needed to define and locate the soils and miscellaneous areas.

Soil scientists make many field observations in the process of producing a soil map. The frequency of observation is dependent upon several factors, including scale of mapping, intensity of mapping, design of map units, complexity of the landscape, and experience of the soil scientist. Observations are made to test and refine the soil-landscape model and predictions and to verify the classification of the soils at specific locations. Once the soil-landscape model is refined, a significantly smaller number of measurements of individual soil properties are made and recorded. These measurements may include field measurements, such as those for color, depth to bedrock, and texture, and laboratory measurements, such as those for content of sand, silt, clay, salt, and other components. Properties of each soil typically vary from one point to another across the landscape.

Observations for map unit components are aggregated to develop ranges of characteristics for the components. The aggregated values are presented. Direct measurements do not exist for every property presented for every map unit component. Values for some properties are estimated from combinations of other properties.

While a soil survey is in progress, samples of some of the soils in the area generally are collected for laboratory analyses and for engineering tests. Soil scientists interpret the data from these analyses and tests as well as the field-observed characteristics and the soil properties to determine the expected behavior of the soils under different uses. Interpretations for all of the soils are field tested through observation of the soils in different uses and under different levels of management. Some interpretations are modified to fit local conditions, and some new interpretations are developed to meet local needs. Data are assembled from other sources, such as research information, production records, and field experience of specialists. For example, data on crop yields under defined levels of management are assembled from farm records and from field or plot experiments on the same kinds of soil.

Predictions about soil behavior are based not only on soil properties but also on such variables as climate and biological activity. Soil conditions are predictable over long periods of time, but they are not predictable from year to year. For example, soil scientists can predict with a fairly high degree of accuracy that a given soil will have a high water table within certain depths in most years, but they cannot predict that a high water table will always be at a specific level in the soil on a specific date.

After soil scientists located and identified the significant natural bodies of soil in the survey area, they drew the boundaries of these bodies on aerial photographs and

Custom Soil Resource Report

identified each as a specific map unit. Aerial photographs show trees, buildings, fields, roads, and rivers, all of which help in locating boundaries accurately.

Soil Map

The soil map section includes the soil map for the defined area of interest, a list of soil map units on the map and extent of each map unit, and cartographic symbols displayed on the map. Also presented are various metadata about data used to produce the map, and a description of each soil map unit.

Custom Soil Resource Report Soil Map







































Map Scale: 1:5,810 if printed on A portrait (8.5" x 11") sheet.

0 50 100 200 300 Meters

0 250 500 1000 1500 Feet

Map projection: Web Mercator Corner coordinates: WGS84 Edge tics: UTM Zone 18N WGS84

MAP LEGEND

Area of Interest (AOI)	 Area of Interest (AOI)	 Spoil Area
Soils	 Soil Map Unit Polygons	 Stony Spot
	 Soil Map Unit Lines	 Very Stony Spot
	 Soil Map Unit Points	 Wet Spot
Special Point Features	 Blowout	 Other
	 Borrow Pit	 Special Line Features
	 Clay Spot	Water Features
	 Closed Depression	 Streams and Canals
	 Gravel Pit	Transportation
	 Gravelly Spot	 Rails
	 Landfill	 Interstate Highways
	 Lava Flow	 US Routes
	 Marsh or swamp	 Major Roads
	 Mine or Quarry	 Local Roads
	 Miscellaneous Water	Background
	 Perennial Water	 Aerial Photography
	 Rock Outcrop	
	 Saline Spot	
	 Sandy Spot	
	 Severely Eroded Spot	
	 Sinkhole	
	 Slide or Slip	
	 Sodic Spot	

MAP INFORMATION

The soil surveys that comprise your AOI were mapped at 1:15,800.

Warning: Soil Map may not be valid at this scale.

Enlargement of maps beyond the scale of mapping can cause misunderstanding of the detail of mapping and accuracy of soil line placement. The maps do not show the small areas of contrasting soils that could have been shown at a more detailed scale.

Please rely on the bar scale on each map sheet for map measurements.

Source of Map: Natural Resources Conservation Service
 Web Soil Survey URL:
 Coordinate System: Web Mercator (EPSG:3857)

Maps from the Web Soil Survey are based on the Web Mercator projection, which preserves direction and shape but distorts distance and area. A projection that preserves area, such as the Albers equal-area conic projection, should be used if more accurate calculations of distance or area are required.

This product is generated from the USDA-NRCS certified data as of the version date(s) listed below.

Soil Survey Area: Schuyler County, New York
 Survey Area Data: Version 18, Sep 1, 2021

Soil map units are labeled (as space allows) for map scales 1:50,000 or larger.

Date(s) aerial images were photographed: Jul 10, 2014—Oct 30, 2016

The orthophoto or other base map on which the soil lines were compiled and digitized probably differs from the background imagery displayed on these maps. As a result, some minor shifting of map unit boundaries may be evident.

Map Unit Legend

Map Unit Symbol	Map Unit Name	Acres in AOI	Percent of AOI
AuC	Aurora channery silt loam, 8 to 15 percent slopes	25.9	17.3%
HrB	Howard gravelly loam, 3 to 8 percent slopes	29.1	19.3%
HrC	Howard gravelly loam, 8 to 15 percent slopes	19.7	13.1%
HrCK	Howard gravelly loam, rolling	10.0	6.7%
HSD	Howard soils, moderately steep	39.8	26.4%
ROF	Rock outcrop-Arnot complex, 25 to 70 percent slopes	0.3	0.2%
ScC3	Schoharie silty clay loam, 8 to 15 percent slopes	2.1	1.4%
ShC3	Schoharie variant silty clay loam, 8 to 15 percent slopes, severely eroded	9.7	6.4%
VaC	Valois gravelly silt loam, 8 to 15 percent slopes	10.5	7.0%
VHF	Valois and Howard soils, very steep	1.1	0.7%
W	Water	2.1	1.4%
Totals for Area of Interest		150.4	100.0%

Map Unit Descriptions

The map units delineated on the detailed soil maps in a soil survey represent the soils or miscellaneous areas in the survey area. The map unit descriptions, along with the maps, can be used to determine the composition and properties of a unit.

A map unit delineation on a soil map represents an area dominated by one or more major kinds of soil or miscellaneous areas. A map unit is identified and named according to the taxonomic classification of the dominant soils. Within a taxonomic class there are precisely defined limits for the properties of the soils. On the landscape, however, the soils are natural phenomena, and they have the characteristic variability of all natural phenomena. Thus, the range of some observed properties may extend beyond the limits defined for a taxonomic class. Areas of soils of a single taxonomic class rarely, if ever, can be mapped without including areas of other taxonomic classes. Consequently, every map unit is made up of the soils or miscellaneous areas for which it is named and some minor components that belong to taxonomic classes other than those of the major soils.

Most minor soils have properties similar to those of the dominant soil or soils in the map unit, and thus they do not affect use and management. These are called noncontrasting, or similar, components. They may or may not be mentioned in a particular map unit description. Other minor components, however, have properties

Custom Soil Resource Report

and behavioral characteristics divergent enough to affect use or to require different management. These are called contrasting, or dissimilar, components. They generally are in small areas and could not be mapped separately because of the scale used. Some small areas of strongly contrasting soils or miscellaneous areas are identified by a special symbol on the maps. If included in the database for a given area, the contrasting minor components are identified in the map unit descriptions along with some characteristics of each. A few areas of minor components may not have been observed, and consequently they are not mentioned in the descriptions, especially where the pattern was so complex that it was impractical to make enough observations to identify all the soils and miscellaneous areas on the landscape.

The presence of minor components in a map unit in no way diminishes the usefulness or accuracy of the data. The objective of mapping is not to delineate pure taxonomic classes but rather to separate the landscape into landforms or landform segments that have similar use and management requirements. The delineation of such segments on the map provides sufficient information for the development of resource plans. If intensive use of small areas is planned, however, onsite investigation is needed to define and locate the soils and miscellaneous areas.

An identifying symbol precedes the map unit name in the map unit descriptions. Each description includes general facts about the unit and gives important soil properties and qualities.

Soils that have profiles that are almost alike make up a *soil series*. Except for differences in texture of the surface layer, all the soils of a series have major horizons that are similar in composition, thickness, and arrangement.

Soils of one series can differ in texture of the surface layer, slope, stoniness, salinity, degree of erosion, and other characteristics that affect their use. On the basis of such differences, a soil series is divided into *soil phases*. Most of the areas shown on the detailed soil maps are phases of soil series. The name of a soil phase commonly indicates a feature that affects use or management. For example, Alpha silt loam, 0 to 2 percent slopes, is a phase of the Alpha series.

Some map units are made up of two or more major soils or miscellaneous areas. These map units are complexes, associations, or undifferentiated groups.

A *complex* consists of two or more soils or miscellaneous areas in such an intricate pattern or in such small areas that they cannot be shown separately on the maps. The pattern and proportion of the soils or miscellaneous areas are somewhat similar in all areas. Alpha-Beta complex, 0 to 6 percent slopes, is an example.

An *association* is made up of two or more geographically associated soils or miscellaneous areas that are shown as one unit on the maps. Because of present or anticipated uses of the map units in the survey area, it was not considered practical or necessary to map the soils or miscellaneous areas separately. The pattern and relative proportion of the soils or miscellaneous areas are somewhat similar. Alpha-Beta association, 0 to 2 percent slopes, is an example.

An *undifferentiated group* is made up of two or more soils or miscellaneous areas that could be mapped individually but are mapped as one unit because similar interpretations can be made for use and management. The pattern and proportion of the soils or miscellaneous areas in a mapped area are not uniform. An area can be made up of only one of the major soils or miscellaneous areas, or it can be made up of all of them. Alpha and Beta soils, 0 to 2 percent slopes, is an example.

Custom Soil Resource Report

Some surveys include *miscellaneous areas*. Such areas have little or no soil material and support little or no vegetation. Rock outcrop is an example.

Schuyler County, New York

AuC—Aurora channery silt loam, 8 to 15 percent slopes

Map Unit Setting

National map unit symbol: 9wjm

Elevation: 1,000 to 1,300 feet

Mean annual precipitation: 32 to 40 inches

Mean annual air temperature: 45 to 48 degrees F

Frost-free period: 120 to 160 days

Farmland classification: Farmland of statewide importance

Map Unit Composition

Aurora and similar soils: 80 percent

Minor components: 20 percent

Estimates are based on observations, descriptions, and transects of the mapunit.

Description of Aurora

Setting

Landform: Till plains, ridges, benches

Landform position (two-dimensional): Summit

Landform position (three-dimensional): Crest

Down-slope shape: Concave

Across-slope shape: Convex

Parent material: Loamy till derived mainly from calcareous shale, with some limestone and sandstone

Typical profile

H1 - 0 to 6 inches: channery silt loam

H2 - 6 to 23 inches: silty clay loam

H3 - 23 to 27 inches: weathered bedrock

Properties and qualities

Slope: 8 to 15 percent

Depth to restrictive feature: 20 to 40 inches to lithic bedrock

Drainage class: Moderately well drained

Capacity of the most limiting layer to transmit water (Ksat): Very low (0.00 to 0.00 in/hr)

Depth to water table: About 18 to 24 inches

Frequency of flooding: None

Frequency of ponding: None

Calcium carbonate, maximum content: 15 percent

Available water supply, 0 to 60 inches: Very low (about 3.0 inches)

Interpretive groups

Land capability classification (irrigated): None specified

Land capability classification (nonirrigated): 3e

Hydrologic Soil Group: D

Ecological site: F140XY028NY - Moist Till Upland

Hydric soil rating: No

Minor Components

Unnamed soils

Percent of map unit: 5 percent

Custom Soil Resource Report

Hydric soil rating: No

Lansing

Percent of map unit: 5 percent

Hydric soil rating: No

Angola

Percent of map unit: 5 percent

Hydric soil rating: No

Conesus

Percent of map unit: 5 percent

Hydric soil rating: No

HrB—Howard gravelly loam, 3 to 8 percent slopes

Map Unit Setting

National map unit symbol: 9wkt

Elevation: 160 to 1,970 feet

Mean annual precipitation: 32 to 40 inches

Mean annual air temperature: 45 to 48 degrees F

Frost-free period: 120 to 160 days

Farmland classification: All areas are prime farmland

Map Unit Composition

Howard and similar soils: 80 percent

Minor components: 20 percent

Estimates are based on observations, descriptions, and transects of the mapunit.

Description of Howard

Setting

Landform: Terraces, valley trains

Landform position (two-dimensional): Summit

Landform position (three-dimensional): Tread

Down-slope shape: Convex

Across-slope shape: Convex

Parent material: Gravelly loamy glaciofluvial deposits over sandy and gravelly glaciofluvial deposits, containing significant amounts of limestone

Typical profile

H1 - 0 to 8 inches: gravelly loam

H2 - 8 to 28 inches: very gravelly loam

H3 - 28 to 36 inches: very gravelly silt loam

H4 - 36 to 54 inches: stratified very gravelly sand

Properties and qualities

Slope: 3 to 8 percent

Depth to restrictive feature: More than 80 inches

Drainage class: Well drained

Capacity of the most limiting layer to transmit water (Ksat): Moderately high to high
(0.57 to 5.95 in/hr)

Custom Soil Resource Report

Depth to water table: More than 80 inches
Frequency of flooding: None
Frequency of ponding: None
Calcium carbonate, maximum content: 15 percent
Available water supply, 0 to 60 inches: Low (about 4.0 inches)

Interpretive groups

Land capability classification (irrigated): None specified
Land capability classification (nonirrigated): 2s
Hydrologic Soil Group: A
Hydric soil rating: No

Minor Components

Castile

Percent of map unit: 5 percent
Hydric soil rating: No

Chenango

Percent of map unit: 5 percent
Hydric soil rating: No

Valois

Percent of map unit: 5 percent
Hydric soil rating: No

Philo

Percent of map unit: 5 percent
Hydric soil rating: No

HrC—Howard gravelly loam, 8 to 15 percent slopes

Map Unit Setting

National map unit symbol: 9wkv
Elevation: 160 to 1,970 feet
Mean annual precipitation: 32 to 40 inches
Mean annual air temperature: 45 to 48 degrees F
Frost-free period: 120 to 160 days
Farmland classification: Farmland of statewide importance

Map Unit Composition

Howard and similar soils: 80 percent
Minor components: 20 percent
Estimates are based on observations, descriptions, and transects of the mapunit.

Description of Howard

Setting

Landform: Terraces, valley trains
Landform position (two-dimensional): Shoulder
Landform position (three-dimensional): Tread
Down-slope shape: Convex

Custom Soil Resource Report

Across-slope shape: Convex

Parent material: Gravelly loamy glaciofluvial deposits over sandy and gravelly glaciofluvial deposits, containing significant amounts of limestone

Typical profile

H1 - 0 to 7 inches: gravelly loam

H2 - 7 to 28 inches: very gravelly loam

H3 - 28 to 36 inches: very gravelly silt loam

H4 - 36 to 54 inches: stratified very gravelly sand

Properties and qualities

Slope: 8 to 15 percent

Depth to restrictive feature: More than 80 inches

Drainage class: Well drained

Capacity of the most limiting layer to transmit water (Ksat): Moderately high to high
(0.57 to 5.95 in/hr)

Depth to water table: More than 80 inches

Frequency of flooding: None

Frequency of ponding: None

Calcium carbonate, maximum content: 15 percent

Available water supply, 0 to 60 inches: Low (about 4.0 inches)

Interpretive groups

Land capability classification (irrigated): None specified

Land capability classification (nonirrigated): 3e

Hydrologic Soil Group: A

Hydric soil rating: No

Minor Components

Valois

Percent of map unit: 5 percent

Hydric soil rating: No

Chenango

Percent of map unit: 5 percent

Hydric soil rating: No

Unnamed soils

Percent of map unit: 5 percent

Hydric soil rating: No

Castile

Percent of map unit: 5 percent

Hydric soil rating: No

HrCK—Howard gravelly loam, rolling

Map Unit Setting

National map unit symbol: 9wkw

Elevation: 160 to 1,970 feet

Mean annual precipitation: 32 to 40 inches

Custom Soil Resource Report

Mean annual air temperature: 45 to 48 degrees F

Frost-free period: 120 to 160 days

Farmland classification: Farmland of statewide importance

Map Unit Composition

Howard and similar soils: 80 percent

Minor components: 20 percent

Estimates are based on observations, descriptions, and transects of the mapunit.

Description of Howard

Setting

Landform: Terraces, valley trains

Landform position (two-dimensional): Shoulder

Landform position (three-dimensional): Tread

Down-slope shape: Convex

Across-slope shape: Convex

Parent material: Gravelly loamy glaciofluvial deposits over sandy and gravelly glaciofluvial deposits, containing significant amounts of limestone

Typical profile

H1 - 0 to 6 inches: gravelly loam

H2 - 6 to 28 inches: very gravelly loam

H3 - 28 to 36 inches: very gravelly silt loam

H4 - 36 to 54 inches: stratified very gravelly sand

Properties and qualities

Slope: 3 to 15 percent

Depth to restrictive feature: More than 80 inches

Drainage class: Well drained

Capacity of the most limiting layer to transmit water (Ksat): Moderately high to high
(0.57 to 5.95 in/hr)

Depth to water table: More than 80 inches

Frequency of flooding: None

Frequency of ponding: None

Calcium carbonate, maximum content: 15 percent

Available water supply, 0 to 60 inches: Low (about 4.0 inches)

Interpretive groups

Land capability classification (irrigated): None specified

Land capability classification (nonirrigated): 3e

Hydrologic Soil Group: A

Hydric soil rating: No

Minor Components

Unnamed soils

Percent of map unit: 5 percent

Hydric soil rating: No

Valois

Percent of map unit: 5 percent

Hydric soil rating: No

Castile

Percent of map unit: 5 percent

Hydric soil rating: No

Chenango

Percent of map unit: 5 percent

Hydric soil rating: No

HSD—Howard soils, moderately steep

Map Unit Setting

National map unit symbol: 9wvx

Elevation: 160 to 1,970 feet

Mean annual precipitation: 32 to 40 inches

Mean annual air temperature: 45 to 48 degrees F

Frost-free period: 120 to 160 days

Farmland classification: Not prime farmland

Map Unit Composition

Howard and similar soils: 80 percent

Minor components: 20 percent

Estimates are based on observations, descriptions, and transects of the mapunit.

Description of Howard

Setting

Landform: Terraces, valley trains

Landform position (two-dimensional): Backslope

Landform position (three-dimensional): Riser

Down-slope shape: Convex

Across-slope shape: Convex

Parent material: Gravelly loamy glaciofluvial deposits over sandy and gravelly glaciofluvial deposits, containing significant amounts of limestone

Typical profile

H1 - 0 to 5 inches: gravelly loam

H2 - 5 to 28 inches: very gravelly loam

H3 - 28 to 36 inches: very gravelly silt loam

H4 - 36 to 54 inches: stratified very gravelly sand

Properties and qualities

Slope: 15 to 25 percent

Depth to restrictive feature: More than 80 inches

Drainage class: Well drained

Capacity of the most limiting layer to transmit water (Ksat): Moderately high to high (0.57 to 5.95 in/hr)

Depth to water table: More than 80 inches

Frequency of flooding: None

Frequency of ponding: None

Calcium carbonate, maximum content: 15 percent

Available water supply, 0 to 60 inches: Low (about 3.9 inches)

Interpretive groups

Land capability classification (irrigated): None specified

Custom Soil Resource Report

Land capability classification (nonirrigated): 4e
Hydrologic Soil Group: A
Hydric soil rating: No

Minor Components

Unnamed soils

Percent of map unit: 5 percent
Hydric soil rating: No

Chenango

Percent of map unit: 5 percent
Hydric soil rating: No

Valois

Percent of map unit: 5 percent
Hydric soil rating: No

Castile

Percent of map unit: 5 percent
Hydric soil rating: No

ROF—Rock outcrop-Arnot complex, 25 to 70 percent slopes

Map Unit Setting

National map unit symbol: 2wbnb
Elevation: 330 to 2,460 feet
Mean annual precipitation: 31 to 70 inches
Mean annual air temperature: 39 to 52 degrees F
Frost-free period: 105 to 180 days
Farmland classification: Not prime farmland

Map Unit Composition

Rock outcrop: 55 percent
Arnot, extremely stony, and similar soils: 40 percent
Minor components: 5 percent
Estimates are based on observations, descriptions, and transects of the mapunit.

Description of Rock Outcrop

Interpretive groups

Land capability classification (irrigated): None specified
Land capability classification (nonirrigated): 8
Hydric soil rating: No

Description of Arnot, Extremely Stony

Setting

Landform: Hills, mountains
Landform position (two-dimensional): Backslope
Landform position (three-dimensional): Mountaintop, mountainflank, free face, nose slope, side slope, free face

Custom Soil Resource Report

Down-slope shape: Linear

Across-slope shape: Linear

Parent material: Loamy till derived mainly from acid sandstone, siltstone, and shale

Typical profile

Oe - 0 to 1 inches: moderately decomposed plant material

A - 1 to 3 inches: channery silt loam

Bw1 - 3 to 12 inches: very channery silt loam

Bw2 - 12 to 17 inches: very channery silt loam

2R - 17 to 27 inches: bedrock

Properties and qualities

Slope: 25 to 70 percent

Surface area covered with cobbles, stones or boulders: 10.0 percent

Depth to restrictive feature: 10 to 20 inches to lithic bedrock

Drainage class: Somewhat excessively drained

Capacity of the most limiting layer to transmit water (Ksat): Moderately low to moderately high (0.14 to 1.42 in/hr)

Depth to water table: More than 80 inches

Frequency of flooding: None

Frequency of ponding: None

Maximum salinity: Nonsaline (0.0 to 1.9 mmhos/cm)

Available water supply, 0 to 60 inches: Very low (about 2.3 inches)

Interpretive groups

Land capability classification (irrigated): None specified

Land capability classification (nonirrigated): 7s

Hydrologic Soil Group: D

Ecological site: F140XY023NY - Shallow Till Uplands

Hydric soil rating: No

Minor Components

Lordstown, extremely stony

Percent of map unit: 5 percent

Landform: Hills, mountains

Landform position (two-dimensional): Backslope

Landform position (three-dimensional): Mountainflank, side slope

Down-slope shape: Linear

Across-slope shape: Linear

Hydric soil rating: No

ScC3—Schoharie silty clay loam, 8 to 15 percent slopes

Map Unit Setting

National map unit symbol: 2xggn

Elevation: 390 to 1,690 feet

Mean annual precipitation: 31 to 57 inches

Mean annual air temperature: 41 to 50 degrees F

Custom Soil Resource Report

Frost-free period: 100 to 190 days

Farmland classification: Not prime farmland

Map Unit Composition

Schoharie and similar soils: 85 percent

Minor components: 15 percent

Estimates are based on observations, descriptions, and transects of the mapunit.

Description of Schoharie

Setting

Landform: Lake terraces

Landform position (two-dimensional): Shoulder, backslope

Landform position (three-dimensional): Riser

Down-slope shape: Convex

Across-slope shape: Convex

Parent material: Red clayey glaciolacustrine deposits derived from calcareous shale

Typical profile

Ap - 0 to 8 inches: silty clay loam

E - 8 to 11 inches: silt loam

Bt/E - 11 to 18 inches: silty clay

Bt - 18 to 33 inches: clay

C1 - 33 to 52 inches: silty clay

C2 - 52 to 79 inches: silty clay

Properties and qualities

Slope: 8 to 15 percent

Depth to restrictive feature: More than 80 inches

Drainage class: Moderately well drained

Runoff class: Medium

Capacity of the most limiting layer to transmit water (Ksat): Very low to moderately low (0.00 to 0.14 in/hr)

Depth to water table: About 18 to 36 inches

Frequency of flooding: None

Frequency of ponding: None

Calcium carbonate, maximum content: 25 percent

Available water supply, 0 to 60 inches: High (about 9.3 inches)

Interpretive groups

Land capability classification (irrigated): None specified

Land capability classification (nonirrigated): 3e

Hydrologic Soil Group: D

Hydric soil rating: No

Minor Components

Odessa

Percent of map unit: 5 percent

Landform: Lake terraces

Landform position (two-dimensional): Footslope

Landform position (three-dimensional): Riser

Down-slope shape: Concave

Across-slope shape: Linear

Hydric soil rating: No

Cazenovia

Percent of map unit: 5 percent
Landform: Till plains, reworked lake plains
Landform position (two-dimensional): Summit
Landform position (three-dimensional): Crest
Down-slope shape: Concave
Across-slope shape: Convex
Hydric soil rating: No

Cayuga

Percent of map unit: 3 percent
Landform: Till plains, lake plains
Landform position (two-dimensional): Summit
Landform position (three-dimensional): Crest, tread
Down-slope shape: Concave
Across-slope shape: Convex
Hydric soil rating: No

Collamer

Percent of map unit: 2 percent
Landform: Lake plains
Landform position (two-dimensional): Summit
Landform position (three-dimensional): Tread
Down-slope shape: Concave
Across-slope shape: Convex
Hydric soil rating: No

ShC3—Schoharie variant silty clay loam, 8 to 15 percent slopes, severely eroded

Map Unit Setting

National map unit symbol: 9wlv
Elevation: 1,000 to 1,800 feet
Mean annual precipitation: 32 to 40 inches
Mean annual air temperature: 45 to 48 degrees F
Frost-free period: 120 to 160 days
Farmland classification: Not prime farmland

Map Unit Composition

Schoharie variant and similar soils: 75 percent
Minor components: 25 percent
Estimates are based on observations, descriptions, and transects of the mapunit.

Description of Schoharie Variant

Setting

Landform: Lake plains
Landform position (two-dimensional): Summit
Landform position (three-dimensional): Tread
Down-slope shape: Concave

Custom Soil Resource Report

Across-slope shape: Convex

Parent material: Reddish clayey and silty glaciolacustrine deposits

Typical profile

H1 - 0 to 6 inches: silty clay loam

H2 - 6 to 24 inches: silty clay loam

H3 - 24 to 28 inches: unweathered bedrock

Properties and qualities

Slope: 8 to 15 percent

Depth to restrictive feature: 20 to 40 inches to lithic bedrock

Drainage class: Moderately well drained

Capacity of the most limiting layer to transmit water (Ksat): Very low (0.00 to 0.00 in/hr)

Depth to water table: About 18 to 24 inches

Frequency of flooding: None

Frequency of ponding: None

Calcium carbonate, maximum content: 1 percent

Available water supply, 0 to 60 inches: Low (about 3.8 inches)

Interpretive groups

Land capability classification (irrigated): None specified

Land capability classification (nonirrigated): 4e

Hydrologic Soil Group: D

Ecological site: F101XY009NY - Moist Lake Plain

Hydric soil rating: No

Minor Components

Collamer

Percent of map unit: 5 percent

Hydric soil rating: No

Hudson

Percent of map unit: 5 percent

Hydric soil rating: No

Dunkirk

Percent of map unit: 5 percent

Hydric soil rating: No

Schoharie

Percent of map unit: 5 percent

Hydric soil rating: No

Odessa

Percent of map unit: 5 percent

Hydric soil rating: No

VaC—Valois gravelly silt loam, 8 to 15 percent slopes

Map Unit Setting

National map unit symbol: 9wm5

Custom Soil Resource Report

Elevation: 600 to 1,750 feet
Mean annual precipitation: 32 to 40 inches
Mean annual air temperature: 45 to 48 degrees F
Frost-free period: 120 to 160 days
Farmland classification: Farmland of statewide importance

Map Unit Composition

Valois and similar soils: 80 percent
Minor components: 20 percent
Estimates are based on observations, descriptions, and transects of the mapunit.

Description of Valois

Setting

Landform: Lateral moraines, valley sides, end moraines
Landform position (two-dimensional): Shoulder
Landform position (three-dimensional): Crest
Down-slope shape: Convex
Across-slope shape: Convex
Parent material: Loamy till derived mainly from sandstone, siltstone, and shale

Typical profile

H1 - 0 to 6 inches: gravelly silt loam
H2 - 6 to 36 inches: gravelly loam
H3 - 36 to 45 inches: gravelly sandy loam
H4 - 45 to 60 inches: very gravelly sandy loam

Properties and qualities

Slope: 8 to 15 percent
Depth to restrictive feature: More than 80 inches
Drainage class: Well drained
Capacity of the most limiting layer to transmit water (Ksat): Moderately high to high (0.57 to 1.98 in/hr)
Depth to water table: More than 80 inches
Frequency of flooding: None
Frequency of ponding: None
Calcium carbonate, maximum content: 2 percent
Available water supply, 0 to 60 inches: Low (about 5.9 inches)

Interpretive groups

Land capability classification (irrigated): None specified
Land capability classification (nonirrigated): 3e
Hydrologic Soil Group: B
Hydric soil rating: No

Minor Components

Bath

Percent of map unit: 5 percent
Hydric soil rating: No

Lansing

Percent of map unit: 5 percent
Hydric soil rating: No

Mardin

Percent of map unit: 5 percent
Hydric soil rating: No

Howard

Percent of map unit: 5 percent
Hydric soil rating: No

VHF—Valois and Howard soils, very steep

Map Unit Setting

National map unit symbol: 9wm8
Elevation: 160 to 1,970 feet
Mean annual precipitation: 32 to 40 inches
Mean annual air temperature: 45 to 48 degrees F
Frost-free period: 120 to 160 days
Farmland classification: Not prime farmland

Map Unit Composition

Valois and similar soils: 40 percent
Howard and similar soils: 35 percent
Minor components: 25 percent
Estimates are based on observations, descriptions, and transects of the mapunit.

Description of Valois

Setting

Landform: Lateral moraines, valley sides, end moraines
Landform position (two-dimensional): Backslope
Landform position (three-dimensional): Side slope
Down-slope shape: Convex
Across-slope shape: Convex
Parent material: Loamy till derived mainly from sandstone, siltstone, and shale

Typical profile

H1 - 0 to 3 inches: gravelly silt loam
H2 - 3 to 25 inches: gravelly loam
H3 - 25 to 34 inches: gravelly sandy loam
H4 - 34 to 60 inches: very gravelly sandy loam

Properties and qualities

Slope: 35 to 50 percent
Depth to restrictive feature: More than 80 inches
Drainage class: Well drained
Capacity of the most limiting layer to transmit water (Ksat): Moderately high to high
(0.57 to 1.98 in/hr)
Depth to water table: More than 80 inches
Frequency of flooding: None
Frequency of ponding: None
Calcium carbonate, maximum content: 2 percent
Available water supply, 0 to 60 inches: Low (about 5.3 inches)

Interpretive groups

Land capability classification (irrigated): None specified

Custom Soil Resource Report

Land capability classification (nonirrigated): 7e
Hydrologic Soil Group: B
Hydric soil rating: No

Description of Howard

Setting

Landform: Terraces, valley trains
Landform position (two-dimensional): Backslope
Landform position (three-dimensional): Riser
Down-slope shape: Convex
Across-slope shape: Convex
Parent material: Gravelly loamy glaciofluvial deposits over sandy and gravelly glaciofluvial deposits, containing significant amounts of limestone

Typical profile

H1 - 0 to 4 inches: gravelly loam
H2 - 4 to 22 inches: very gravelly loam
H3 - 22 to 31 inches: very gravelly silt loam
H4 - 31 to 54 inches: stratified very gravelly sand

Properties and qualities

Slope: 35 to 60 percent
Depth to restrictive feature: More than 80 inches
Drainage class: Well drained
Capacity of the most limiting layer to transmit water (Ksat): Moderately high to high (0.57 to 5.95 in/hr)
Depth to water table: More than 80 inches
Frequency of flooding: None
Frequency of ponding: None
Calcium carbonate, maximum content: 15 percent
Available water supply, 0 to 60 inches: Low (about 3.5 inches)

Interpretive groups

Land capability classification (irrigated): None specified
Land capability classification (nonirrigated): 7e
Hydrologic Soil Group: A
Hydric soil rating: No

Minor Components

Chenango

Percent of map unit: 5 percent
Hydric soil rating: No

Bath

Percent of map unit: 5 percent
Hydric soil rating: No

Lansing

Percent of map unit: 5 percent
Hydric soil rating: No

Lordstown

Percent of map unit: 5 percent
Hydric soil rating: No

Unnamed soils

Percent of map unit: 5 percent

Custom Soil Resource Report

Hydric soil rating: No

W—Water

Map Unit Setting

National map unit symbol: 9wmf

Mean annual precipitation: 32 to 40 inches

Mean annual air temperature: 45 to 48 degrees F

Frost-free period: 120 to 160 days

Farmland classification: Not prime farmland

Map Unit Composition

Water: 100 percent

Estimates are based on observations, descriptions, and transects of the mapunit.

References

- American Association of State Highway and Transportation Officials (AASHTO). 2004. Standard specifications for transportation materials and methods of sampling and testing. 24th edition.
- American Society for Testing and Materials (ASTM). 2005. Standard classification of soils for engineering purposes. ASTM Standard D2487-00.
- Cowardin, L.M., V. Carter, F.C. Golet, and E.T. LaRoe. 1979. Classification of wetlands and deep-water habitats of the United States. U.S. Fish and Wildlife Service FWS/OBS-79/31.
- Federal Register. July 13, 1994. Changes in hydric soils of the United States.
- Federal Register. September 18, 2002. Hydric soils of the United States.
- Hurt, G.W., and L.M. Vasilas, editors. Version 6.0, 2006. Field indicators of hydric soils in the United States.
- National Research Council. 1995. Wetlands: Characteristics and boundaries.
- Soil Survey Division Staff. 1993. Soil survey manual. Soil Conservation Service. U.S. Department of Agriculture Handbook 18. http://www.nrcs.usda.gov/wps/portal/nrcs/detail/national/soils/?cid=nrcs142p2_054262
- Soil Survey Staff. 1999. Soil taxonomy: A basic system of soil classification for making and interpreting soil surveys. 2nd edition. Natural Resources Conservation Service, U.S. Department of Agriculture Handbook 436. http://www.nrcs.usda.gov/wps/portal/nrcs/detail/national/soils/?cid=nrcs142p2_053577
- Soil Survey Staff. 2010. Keys to soil taxonomy. 11th edition. U.S. Department of Agriculture, Natural Resources Conservation Service. http://www.nrcs.usda.gov/wps/portal/nrcs/detail/national/soils/?cid=nrcs142p2_053580
- Tiner, R.W., Jr. 1985. Wetlands of Delaware. U.S. Fish and Wildlife Service and Delaware Department of Natural Resources and Environmental Control, Wetlands Section.
- United States Army Corps of Engineers, Environmental Laboratory. 1987. Corps of Engineers wetlands delineation manual. Waterways Experiment Station Technical Report Y-87-1.
- United States Department of Agriculture, Natural Resources Conservation Service. National forestry manual. http://www.nrcs.usda.gov/wps/portal/nrcs/detail/soils/home/?cid=nrcs142p2_053374
- United States Department of Agriculture, Natural Resources Conservation Service. National range and pasture handbook. <http://www.nrcs.usda.gov/wps/portal/nrcs/detail/national/landuse/rangepasture/?cid=stelprdb1043084>

Custom Soil Resource Report

United States Department of Agriculture, Natural Resources Conservation Service. National soil survey handbook, title 430-VI. http://www.nrcs.usda.gov/wps/portal/nrcs/detail/soils/scientists/?cid=nrcs142p2_054242

United States Department of Agriculture, Natural Resources Conservation Service. 2006. Land resource regions and major land resource areas of the United States, the Caribbean, and the Pacific Basin. U.S. Department of Agriculture Handbook 296. http://www.nrcs.usda.gov/wps/portal/nrcs/detail/national/soils/?cid=nrcs142p2_053624

United States Department of Agriculture, Soil Conservation Service. 1961. Land capability classification. U.S. Department of Agriculture Handbook 210. http://www.nrcs.usda.gov/Internet/FSE_DOCUMENTS/nrcs142p2_052290.pdf



APPENDIX B

SOIL TYPE AND GROUND COVER TABLE

	EXISTING CONDITION				POST-RECLAMATION CONDITION				Traffic Area	
	sq-ft	acres	HSG A	HSG B	sq-ft	acres	HSG A	HSG B		HSG D
Infiltration Area 1										
Area 1	255481	5.87	67221	188260	265195	6.09	76935	188260	0	56691
Area 1C	17590	0.40	17590	0	Diverted					
Area 1D	5578	0.13	5578	0	Diverted					
Area 1E	14077	0.32	1003	13074	14077	0.32	1003	13074	0	
	292726	6.72	91392	201334	279272	6.41	77938	201334	0	
HSG B - Traffic Area				151324				144643		
Internal Area 2										
Area 2	55334	1.27	45550	9784	55334	1.27	45550	9784	0	
Area 2A	14279	0.33	14279	0	Diverted					
	69613	1.60	59829	9784	55334	1.27	45550	9784	0	
Infiltration Area 3										
Area 3	589574	13.53	518721	70853	240062	5.51	169209	70853	0	45301
Area 3C	5486	0.13	5486	0	Diverted					
Uncaptured Upslope										
	595060	13.66	524207	70853	240062	5.51	169209	70853	0	
HSG B - Traffic Area				25552				25552		
Area 4 Mined Area										
Area 4	794273	18.23	794273	0	2641679	60.64	2632942	441	8296	
Area 4D	8050	0.18	8050	0	8050	0.18	8050			
Ponds (Open Water)										
Area 4 Ground	802323	18.42	802323	0	2649729	60.83	2640992	441	8296	
	25300	0.58			22977	0.53				
	777023	17.84			2626752	60.30				
Uncaptured Area 4					Incorporated into Area 4					
Area 4C	52402	1.20	52402	0						
Infiltration Area 5										
Upland Wooded	602677	13.84	602677	0	Diverted					
Area 5 Wooded	134740	3.09	134740	0	Incorporated into Area 4					
Area 5 Open (Pasture/Grass)	817034	18.76	817034	0	Incorporated into Area 4					
	1554451	35.69	1554451	0						



APPENDIX C
NOAA ATLAS 14
PRECIPITATION DATA



POINT PRECIPITATION FREQUENCY ESTIMATES

Sanja Perica, Sandra Pavlovic, Michael St. Laurent, Carl Trypaluk, Dale Unruh, Orlan Wilhite

NOAA, National Weather Service, Silver Spring, Maryland

[PF_tabular](#) | [PF_graphical](#) | [Maps & aerials](#)

PF tabular

PDS-based point precipitation frequency estimates with 90% confidence intervals (in inches)¹										
Duration	Average recurrence interval (years)									
	1	2	5	10	25	50	100	200	500	1000
5-min	0.290 (0.219-0.381)	0.352 (0.266-0.463)	0.454 (0.343-0.599)	0.539 (0.405-0.715)	0.656 (0.480-0.904)	0.744 (0.534-1.04)	0.836 (0.587-1.21)	0.941 (0.628-1.39)	1.09 (0.707-1.66)	1.22 (0.771-1.88)
10-min	0.410 (0.311-0.539)	0.499 (0.378-0.656)	0.644 (0.486-0.849)	0.764 (0.574-1.01)	0.929 (0.680-1.28)	1.05 (0.758-1.48)	1.19 (0.832-1.72)	1.33 (0.891-1.96)	1.55 (1.00-2.35)	1.73 (1.09-2.66)
15-min	0.483 (0.366-0.634)	0.587 (0.444-0.772)	0.757 (0.571-0.999)	0.898 (0.675-1.19)	1.09 (0.800-1.51)	1.24 (0.891-1.74)	1.39 (0.979-2.02)	1.57 (1.05-2.31)	1.82 (1.18-2.76)	2.03 (1.29-3.13)
30-min	0.654 (0.495-0.859)	0.795 (0.602-1.05)	1.03 (0.774-1.35)	1.22 (0.914-1.62)	1.48 (1.08-2.04)	1.68 (1.21-2.36)	1.89 (1.33-2.74)	2.12 (1.42-3.13)	2.47 (1.59-3.74)	2.75 (1.74-4.24)
60-min	0.825 (0.625-1.09)	1.00 (0.759-1.32)	1.29 (0.977-1.71)	1.54 (1.15-2.04)	1.87 (1.37-2.57)	2.12 (1.52-2.97)	2.38 (1.67-3.45)	2.68 (1.79-3.95)	3.11 (2.01-4.72)	3.47 (2.20-5.35)
2-hr	1.01 (0.770-1.32)	1.22 (0.930-1.60)	1.57 (1.19-2.06)	1.86 (1.40-2.45)	2.25 (1.66-3.09)	2.55 (1.84-3.57)	2.86 (2.03-4.16)	3.24 (2.17-4.75)	3.82 (2.48-5.77)	4.32 (2.74-6.62)
3-hr	1.13 (0.865-1.47)	1.37 (1.04-1.78)	1.75 (1.33-2.29)	2.07 (1.57-2.72)	2.51 (1.85-3.44)	2.83 (2.06-3.96)	3.18 (2.27-4.63)	3.62 (2.43-5.28)	4.29 (2.78-6.45)	4.87 (3.10-7.45)
6-hr	1.37 (1.05-1.77)	1.65 (1.27-2.14)	2.12 (1.62-2.75)	2.50 (1.90-3.26)	3.03 (2.25-4.13)	3.42 (2.50-4.77)	3.84 (2.76-5.58)	4.38 (2.95-6.36)	5.22 (3.40-7.81)	5.96 (3.80-9.06)
12-hr	1.65 (1.27-2.12)	2.00 (1.54-2.57)	2.56 (1.97-3.31)	3.04 (2.32-3.94)	3.68 (2.75-4.99)	4.16 (3.06-5.76)	4.68 (3.38-6.75)	5.33 (3.61-7.70)	6.35 (4.14-9.44)	7.22 (4.62-10.9)
24-hr	1.94 (1.50-2.47)	2.35 (1.82-3.01)	3.04 (2.35-3.90)	3.61 (2.77-4.65)	4.39 (3.29-5.91)	4.96 (3.66-6.83)	5.59 (4.04-8.00)	6.37 (4.32-9.15)	7.57 (4.96-11.2)	8.61 (5.52-12.9)
2-day	2.22 (1.73-2.82)	2.70 (2.10-3.44)	3.50 (2.71-4.46)	4.15 (3.21-5.32)	5.06 (3.81-6.78)	5.73 (4.24-7.84)	6.45 (4.69-9.19)	7.36 (5.01-10.5)	8.77 (5.76-12.9)	9.99 (6.43-14.9)
3-day	2.42 (1.90-3.07)	2.94 (2.30-3.73)	3.79 (2.95-4.81)	4.49 (3.48-5.73)	5.45 (4.12-7.28)	6.16 (4.58-8.41)	6.94 (5.06-9.85)	7.91 (5.39-11.3)	9.41 (6.20-13.8)	10.7 (6.91-16.0)
4-day	2.61 (2.05-3.29)	3.15 (2.46-3.97)	4.02 (3.14-5.10)	4.75 (3.69-6.05)	5.75 (4.35-7.65)	6.49 (4.83-8.82)	7.29 (5.32-10.3)	8.29 (5.67-11.8)	9.85 (6.49-14.4)	11.2 (7.23-16.6)
7-day	3.13 (2.46-3.93)	3.70 (2.91-4.64)	4.63 (3.62-5.83)	5.39 (4.20-6.83)	6.45 (4.90-8.53)	7.24 (5.40-9.76)	8.09 (5.90-11.3)	9.12 (6.25-12.9)	10.7 (7.08-15.6)	12.1 (7.82-17.9)
10-day	3.63 (2.87-4.55)	4.22 (3.33-5.29)	5.18 (4.07-6.51)	5.98 (4.67-7.54)	7.07 (5.38-9.30)	7.89 (5.89-10.6)	8.77 (6.39-12.2)	9.81 (6.74-13.8)	11.4 (7.54-16.5)	12.7 (8.24-18.8)
20-day	5.16 (4.09-6.41)	5.80 (4.59-7.22)	6.85 (5.41-8.55)	7.72 (6.06-9.68)	8.91 (6.79-11.6)	9.82 (7.33-13.0)	10.8 (7.80-14.7)	11.8 (8.15-16.5)	13.2 (8.82-19.1)	14.4 (9.38-21.2)
30-day	6.43 (5.11-7.96)	7.12 (5.65-8.82)	8.24 (6.53-10.2)	9.18 (7.23-11.5)	10.5 (7.98-13.5)	11.5 (8.55-15.0)	12.5 (9.00-16.8)	13.5 (9.35-18.7)	14.9 (9.93-21.3)	15.9 (10.4-23.3)
45-day	7.99 (6.38-9.86)	8.75 (6.97-10.8)	9.99 (7.93-12.4)	11.0 (8.70-13.7)	12.4 (9.50-15.9)	13.5 (10.1-17.6)	14.6 (10.5-19.6)	15.7 (10.9-21.7)	17.0 (11.4-24.3)	18.0 (11.8-26.3)
60-day	9.30 (7.44-11.4)	10.1 (8.08-12.5)	11.5 (9.12-14.2)	12.6 (9.95-15.6)	14.1 (10.8-18.0)	15.3 (11.4-19.9)	16.4 (11.9-21.9)	17.5 (12.2-24.2)	18.9 (12.7-27.0)	19.9 (13.0-28.9)

¹ Precipitation frequency (PF) estimates in this table are based on frequency analysis of partial duration series (PDS). Numbers in parenthesis are PF estimates at lower and upper bounds of the 90% confidence interval. The probability that precipitation frequency estimates (for a given duration and average recurrence interval) will be greater than the upper bound (or less than the lower bound) is 5%. Estimates at upper bounds are not checked against probable maximum precipitation (PMP) estimates and may be higher than currently valid PMP values. Please refer to NOAA Atlas 14 document for more information.

[Back to Top](#)

PF graphical

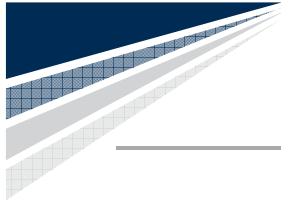

APPENDIX D
EXISTING CONDITION
TEMPORARY SEDIMENT BASIN DESIGN
DATA SHEET AND DISCHARGE STRUCTURE

TEMPORARY SEDIMENT BASIN DESIGN DATA SHEET

Computed by P. Adel Date 1/3/2022 Checked by _____ Date _____
Project IGN Padua Ridge Basin # Area 4 - Existing Condition
Location Watkins Glen, NY Total Area draining to basin (≤ 50 Ac.) 18.42 Acres

BASIN SIZE DESIGN

(Provided)

- Sediment storage zone volume = 1,000 cu. ft. x number of disturbed acres = 18,420 cu. ft., Top of Zone Elev. 832 (19,727)
- Dewatering zone volume = 3,600 cu. ft. x number of drainage area acres = 66,312 cu. ft., Top of Zone Elev. 834.8 (66,918)
- Length to width ratio = linear sequence of ponds
- A. Cleanout at 50% of sediment storage zone volume, Elev. 831.5
B. Distance below top of riser 3.7 feet
- Minimum surface area is larger of 0.01 $Q_{(10)}$.57 or, 0.015 DA = 0.28 use 0.57 acres (30,706 @ 834.8)
24,829 sq ft

DESIGN OF SPILLWAYS & ELEVATIONS

Runoff

- $Q_{p(10)}$ = 56.46 cfs (Attach runoff computation sheets)

~~Pipe Spillway (Q_{ps})~~ Sharp crested weir 3.5 ft wide

- Min. pipe spillway cap., $Q_{ps} = 0.2 \times$ 18.42 Drainage Area, acres = 3.7 cfs Weir Controls Peak discharge during 10-yr/24-hr storm = 1.19 cfs @ 834.92 ft elev. See HydroCAD Report
Note: If there is no emergency spillway, then required $Q_{ps} = Q_{p(10)} =$ _____ cfs.
- H, head = 2.8 ft. Barrel length = 118 ft
- Barrel: Diam. 24 inches; $Q_{ps} = (Q)$ _____ x (cor. fac.) _____ = 20.96 cfs. @ 834.92
- Riser: Diam. _____ inches; Length _____ ft.; h = _____ ft. Crest Elev. 834.8
- Trash Rack: Diameter = _____ inches; H, height = _____ inches

Emergency Spillway Design Second Weir 6 ft wide - No discharge during 10-yr or 25-yr storm. See HydroCAD Report

- Emergency Spillway Flow, $Q_{es} = Q_p - Q_{ps} =$ _____ - _____ = 22.67 cfs. @ 835.25 Peak discharge during 25-yr/24-hr storm = 4.08 cfs @ 835.25 ft elev.
- Width 6 ft.; H_p NA ft Crest elevation 835.3; Design High Water Elev. 834.92
Entrance channel slope _____ %; Top of Dam Elev. 836
Exit channel slope _____ %

ANTI-SEEP COLLAR/SEEPAGE DIAPHRAGM DESIGN

See Anti-Seep Analysis for Pre-Reclamation Condition

Collars:

- $y =$ _____ ft.; $z =$ _____ :1; pipe slope = _____ %, $L_s =$ _____ ft.
Use _____ collars, _____ - _____ inches square; projection = _____ ft.

Diaphragms:

_____ width _____ ft. height _____ ft.

DEWATERING ORIFICE SIZING

(Determined from the Dewatering Device Standard)

- Dewatering orifice diameter = 4 @ 2 inches. Skimmer _____ or Riser X (check one)
- Design dewatering time >3 days (Min. 2 days required)

TEMPORARY SEDIMENT BASIN DESIGN DATA SHEET

INSTRUCTIONS FOR USE OF FORM

1. Minimum required sediment storage zone volume is 1,000 cubic feet per acre from each disturbed acre within the total drainage area. Minimum required dewatering zone volume is 3,600 cubic feet per total area draining to the basin.
2. The volume of a naturally shaped basin (no excavation in basin) may be approximated by the formula $V = (0.4)(A)(d)$, where V is in cubic feet, A is the surface area of the basin, in square feet, and d is the maximum depth of the basin, in feet. Volume may be computed from contour information or other suitable methods.
3. If volume of basin is not adequate for required storage, excavate to obtain the required zone volumes.
4. The minimum surface area of the basin pool at the storage volume elevation will be the larger of the two elevations shown.
5. Use of the NRCC hydrologic data at www.precip.net with an appropriate hydrologic model, is the preferred process for runoff computation. Runoff curve numbers will be computed for the drainage area that reflects the maximum construction condition.
6. Required minimum discharge from pipe spillway equals 0.2 cfs/ac. times total drainage area. (This is equivalent to a uniform runoff of 5 in. per 24 hours). The pipe shall be designed to carry Q_p if site conditions preclude installation of an emergency spillway to protect the structure.
7. Determine value of "H" from field conditions; "H" is the interval between the centerline of the outlet pipe and the emergency spillway crest, or if there is no emergency spillway, to the design high water.
8. See Pipe Flow Charts, Figures 5.11 and 5.12 on pages 5.29 and 5.30.
9. See Riser Inflow Curves, Figure 5.10 on page 5.28.
10. Compute the orifice size required to dewater the basin over a minimum 48 hour period. See the Dewatering Device Standard on page 5.10.
11. See Trash Rack and Anti-Vortex Device Design, Figures 5.13 and 5.14 on pages 5.31 and 5.32.
12. Compute Q_{es} by subtracting actual flow carried by the pipe spillway from the total inflow, Q_p .
13. Use appropriate tables to obtain values of H_p , bottom width, and actual Q_{es} . If no emergency spillway is to be used, so state, giving reason (s).
14. See Anti-Seep Collar / Seepage Diaphragm Design (see figures 5.16, 5.17 and 5.18 on pages 5.34, 5.35 and 5.36).
15. Fill in design elevations. The emergency spillway crest must be set no closer to riser crest than value of h , which causes pipe spillway to carry the minimum, required Q . Therefore, the elevation difference between spillways shall be equal to the value of h , or one foot, whichever is greater. Design high water is the elevation of the emergency spillway crest plus the value of H_p , or if there is no emergency spillway, it is the elevation of the riser crest plus h required to handle the 10-year storm. Minimum top of dam elevation requires 1.0 ft. of freeboard above design high water.

To use charts for pipe spillway design:

1. Enter chart, Figures 5.11 or 5.12 on pages 5.29 and 5.30 with H and required discharge.
2. Find diameter of pipe conduit that provides equal or greater discharge
3. Enter chart, Figure 5.10 on page 5.28 with actual pipe discharge. Read across to select smallest riser that provides discharge within weir flow portion of rating curve. Read down to find corresponding h required. This h must be 1 foot or less.

**Figure 5.9
Sediment Basin**

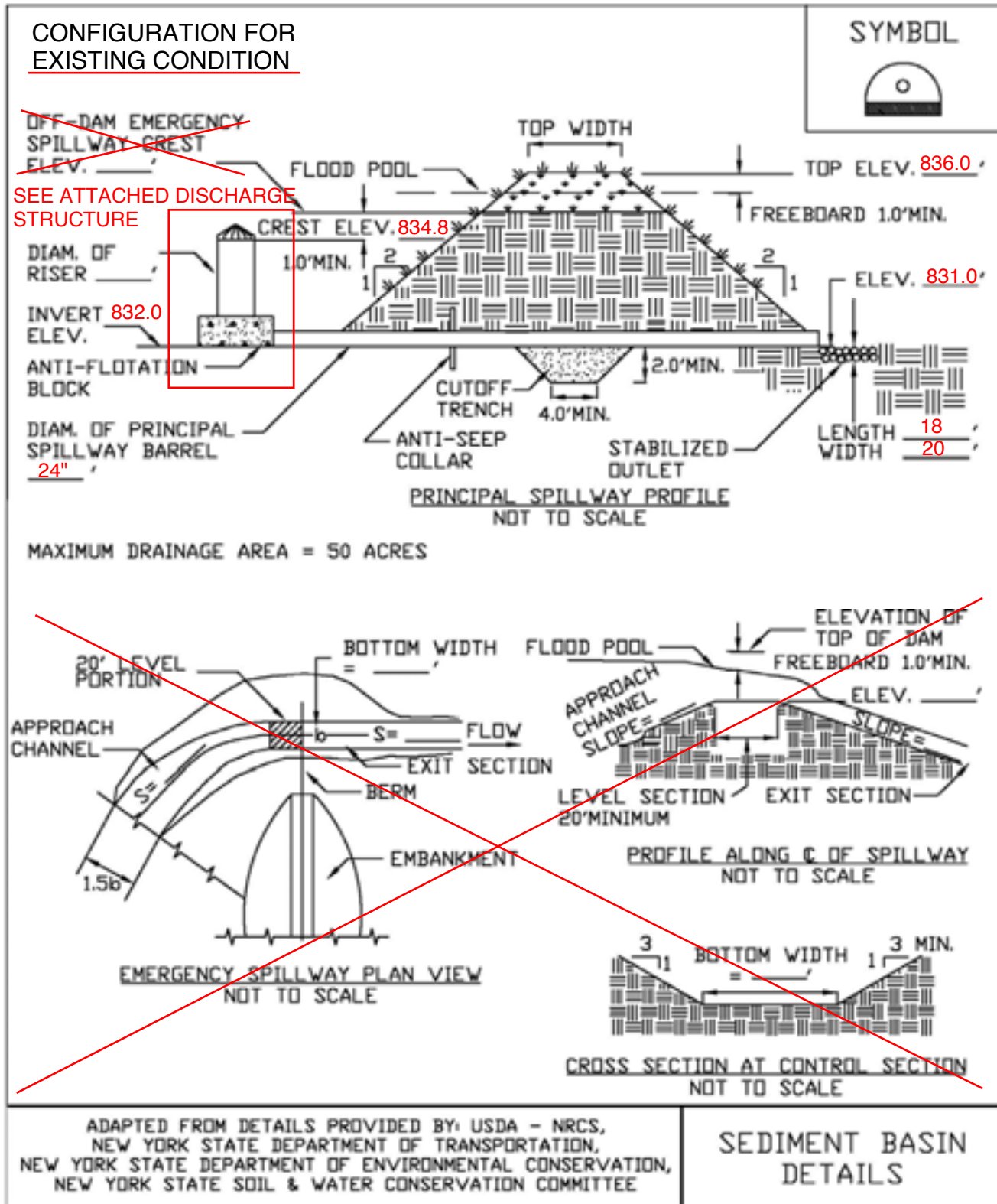

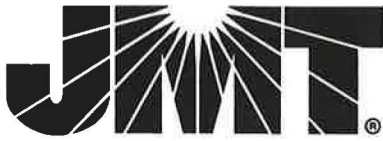

Project _____

Subject _____ Job No. _____

Sheet No. _____ of _____

Computed By _____ Date _____ Checked By _____ Date _____

**OUTFALL
STRUCTURE
CONFIGURATION
FOR EXISTING
CONDITION**

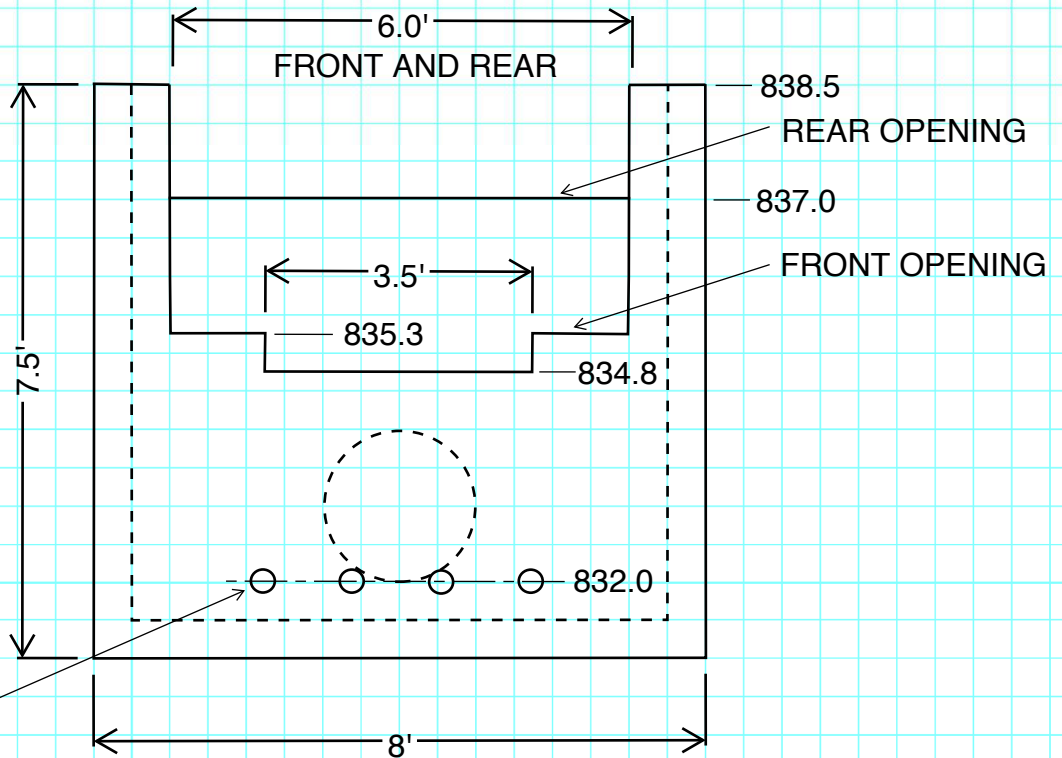

4 @ 3" LOW
LEVEL ORIFICE
PROTECT WITH
DEBRIS RACK

INSTALL 2" ORIFICE REDUCERS
FOR EXISTING CONDITION

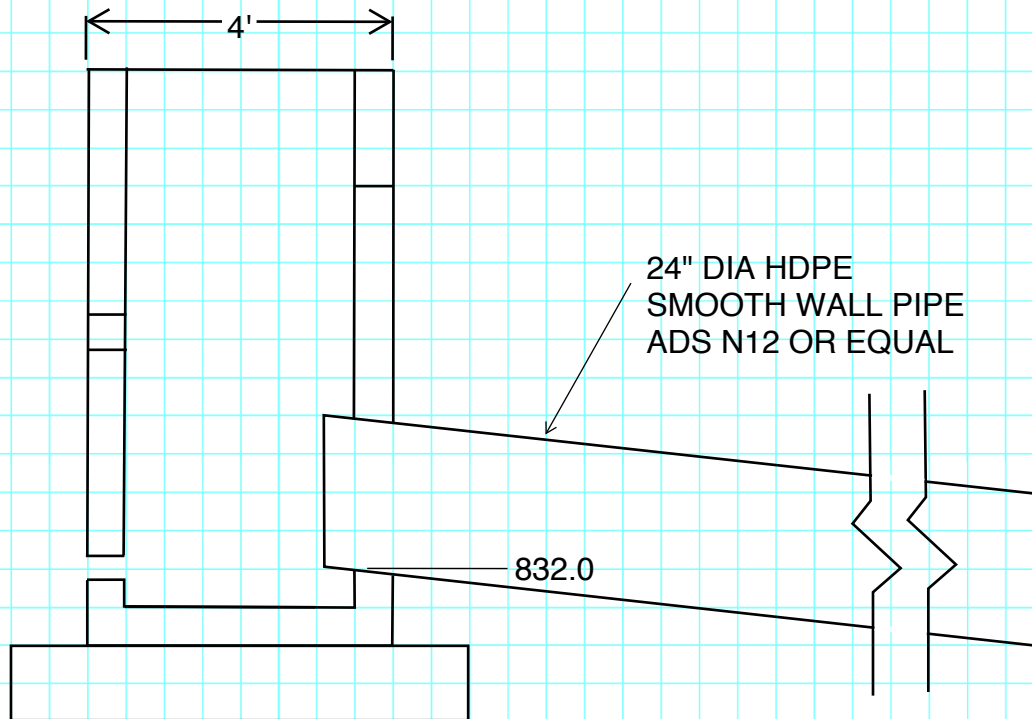

24" DIA HDPE
SMOOTH WALL PIPE
ADS N12 OR EQUAL

832.0

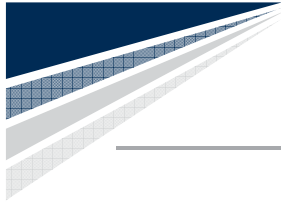

APPENDIX E
PRE-RECLAMATION CONDITION
TEMPORARY SEDIMENT BASIN DESIGN
DATA SHEET AND DISCHARGE STRUCTURE

TEMPORARY SEDIMENT BASIN DESIGN DATA SHEET

Computed by P. Adel Date 1/3/2022 Checked by _____ Date _____
Project IGN Padua Ridge Basin # Area 4 - Pre-Reclamation
Location Watkins Glen, NY Total Area draining to basin (≤ 50 Ac.) 60.83 Acres

BASIN SIZE DESIGN

(Provided)

- Sediment storage zone volume = 1,000 cu. ft. x number of disturbed acres = 60,830 cu. ft., Top of Zone Elev. 832 (61,614)
- Dewatering zone volume = 3,600 cu. ft. x number of drainage area acres = 218,988 cu. ft., Top of Zone Elev. 838.2 (219,495)
- Length to width ratio = 2:1 with baffle
- A. Cleanout at 50% of sediment storage zone volume, Elev. 830.2
B. Distance below top of riser 8 feet
- Minimum surface area is larger of $0.01 Q_{(10)}$ 0.81 or, $0.015 DA$ = 0.9 use 0.9 acres (50,124) @838.2
39,204 sq ft

DESIGN OF SPILLWAYS & ELEVATIONS

Runoff

- $Q_{p(10)}$ = 81.16 cfs (Attach runoff computation sheets)

~~Pipe Spillway (Q_{ps})~~ 2 @ Sharp crested weir 3.5 ft wide

- Min. pipe spillway cap., $Q_{ps} = 0.2 \times$ 60.83 Drainage Area, acres = 12.2 cfs Weir Controls Peak discharge during 10-yr/24-hr storm = 3.44 cfs @ 838.33 ft elev.
Note: If there is no emergency spillway, then required $Q_{ps} = Q_{p(10)}$ = _____ cfs.
- H, head = 6.5 ft. Barrel length = 118 ft See HydroCAD Report
- Barrel: Diam. 24 inches; $Q_{ps} = (Q)$ _____ x (cor. fac.) _____ = 33.76 cfs. @ 838.33
- Riser: Diam. _____ inches; Length _____ ft.; h = _____ ft. Crest Elev. 838.2
- Trash Rack: Diameter = _____ inches; H, height = _____ inches

Emergency Spillway Design Second Weir 20 ft long - No discharge during 10-yr storm. See HydroCAD Report

- Emergency Spillway Flow, $Q_{es} = Q_p - Q_{ps} =$ _____ - _____ = 35.15 cfs. @ 838.78 Peak discharge during 25-yr/24-hr storm = 18.63 cfs @ 838.78 ft elev.
- Width 20 ft.; H_p NA ft Crest elevation 838.5; Design High Water Elev. 838.33
Entrance channel slope _____ %; Top of Dam Elev. 840
Exit channel slope _____ %

ANTI-SEEP COLLAR/SEEPAGE DIAPHRAGM DESIGN

Collars:

- $y =$ 6.4 ft.; $z =$ 2.5 :1; pipe slope = 0.0085 %, $L_s =$ 42.4 ft.
Use 2 collars, 5 ft - 3 inches square; projection = 1.63 ft. Spacing 14 ft = 8.7 x projection (btwn 5 and 14 times projection)

Diaphragms:

_____ width _____ ft. height _____ ft.

DEWATERING ORIFICE SIZING

(Determined from the Dewatering Device Standard)

- Dewatering orifice diameter = 2 @ 3 inches. Skimmer _____ or Riser X (check one)
- Design dewatering time 3 days (Min. 2 days required)

TEMPORARY SEDIMENT BASIN DESIGN DATA SHEET

INSTRUCTIONS FOR USE OF FORM

1. Minimum required sediment storage zone volume is 1,000 cubic feet per acre from each disturbed acre within the total drainage area. Minimum required dewatering zone volume is 3,600 cubic feet per total area draining to the basin.
2. The volume of a naturally shaped basin (no excavation in basin) may be approximated by the formula $V = (0.4)(A)(d)$, where V is in cubic feet, A is the surface area of the basin, in square feet, and d is the maximum depth of the basin, in feet. Volume may be computed from contour information or other suitable methods.
3. If volume of basin is not adequate for required storage, excavate to obtain the required zone volumes.
4. The minimum surface area of the basin pool at the storage volume elevation will be the larger of the two elevations shown.
5. Use of the NRCC hydrologic data at www.precip.net with an appropriate hydrologic model, is the preferred process for runoff computation. Runoff curve numbers will be computed for the drainage area that reflects the maximum construction condition.
6. Required minimum discharge from pipe spillway equals 0.2 cfs/ac. times total drainage area. (This is equivalent to a uniform runoff of 5 in. per 24 hours). The pipe shall be designed to carry Q_p if site conditions preclude installation of an emergency spillway to protect the structure.
7. Determine value of "H" from field conditions; "H" is the interval between the centerline of the outlet pipe and the emergency spillway crest, or if there is no emergency spillway, to the design high water.
8. See Pipe Flow Charts, Figures 5.11 and 5.12 on pages 5.29 and 5.30.
9. See Riser Inflow Curves, Figure 5.10 on page 5.28.
10. Compute the orifice size required to dewater the basin over a minimum 48 hour period. See the Dewatering Device Standard on page 5.10.
11. See Trash Rack and Anti-Vortex Device Design, Figures 5.13 and 5.14 on pages 5.31 and 5.32.
12. Compute Q_{es} by subtracting actual flow carried by the pipe spillway from the total inflow, Q_p .
13. Use appropriate tables to obtain values of H_p , bottom width, and actual Q_{es} . If no emergency spillway is to be used, so state, giving reason (s).
14. See Anti-Seep Collar / Seepage Diaphragm Design (see figures 5.16, 5.17 and 5.18 on pages 5.34, 5.35 and 5.36).
15. Fill in design elevations. The emergency spillway crest must be set no closer to riser crest than value of h , which causes pipe spillway to carry the minimum, required Q . Therefore, the elevation difference between spillways shall be equal to the value of h , or one foot, whichever is greater. Design high water is the elevation of the emergency spillway crest plus the value of H_p , or if there is no emergency spillway, it is the elevation of the riser crest plus h required to handle the 10-year storm. Minimum top of dam elevation requires 1.0 ft. of freeboard above design high water.

To use charts for pipe spillway design:

1. Enter chart, Figures 5.11 or 5.12 on pages 5.29 and 5.30 with H and required discharge.
2. Find diameter of pipe conduit that provides equal or greater discharge
3. Enter chart, Figure 5.10 on page 5.28 with actual pipe discharge. Read across to select smallest riser that provides discharge within weir flow portion of rating curve. Read down to find corresponding h required. This h must be 1 foot or less.

Figure 5.9 Sediment Basin

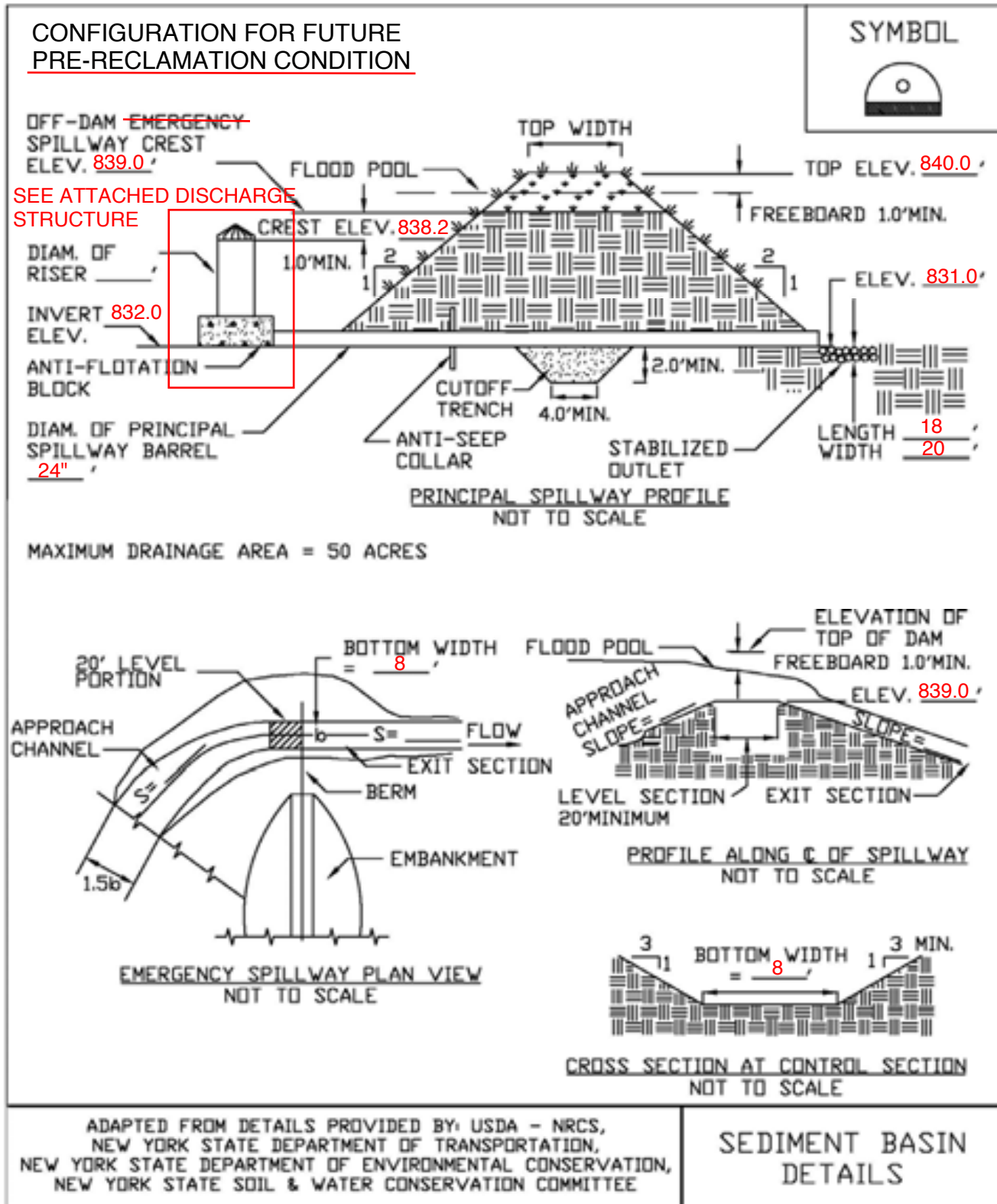

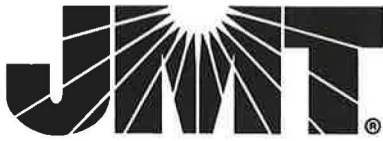

Project _____

Subject _____ Job No. _____

Sheet No. _____ of _____

Computed By _____ Date _____ Checked By _____ Date _____

OUTFALL
STRUCTURE
CONFIGURATION
FOR FUTURE
PRE-RECLAMATION
CONDITION

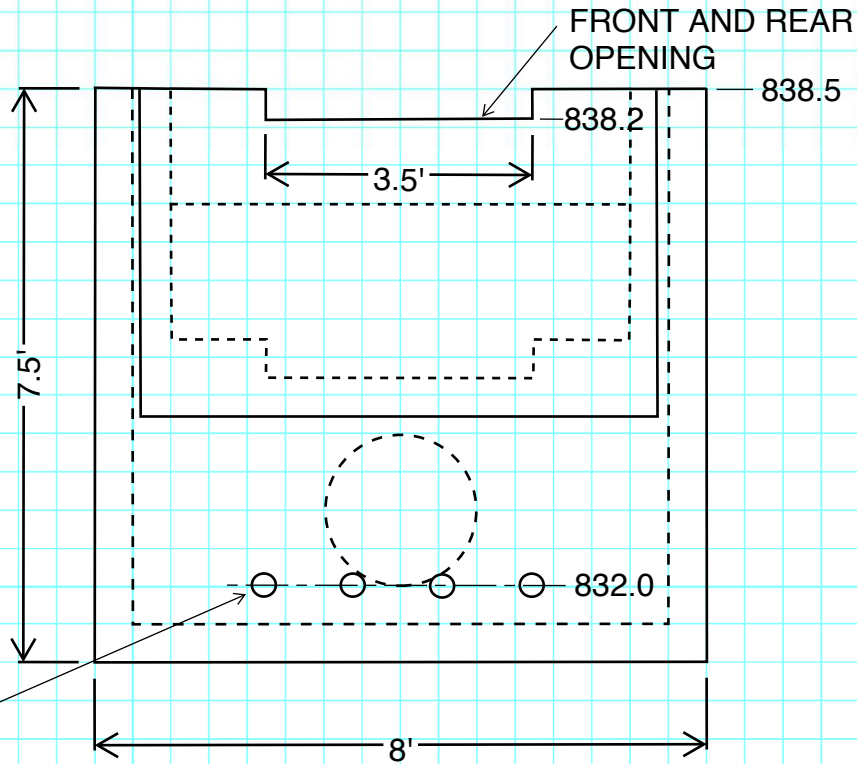

4 @ 3" LOW
LEVEL ORIFICE
PROTECT WITH
DEBRIS RACK

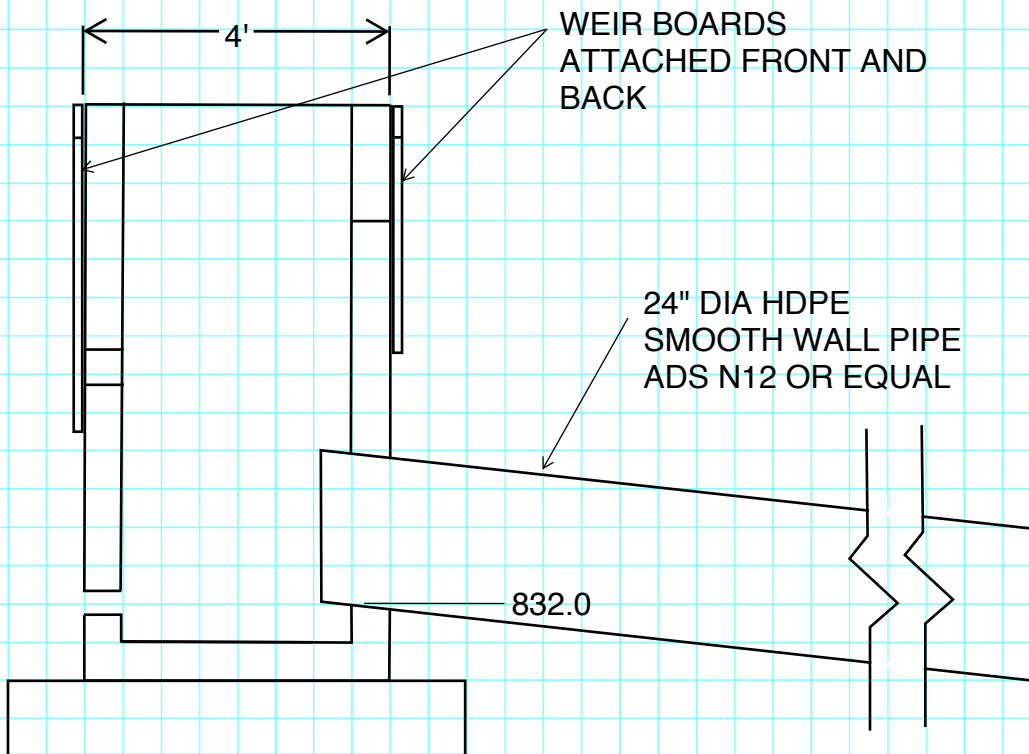

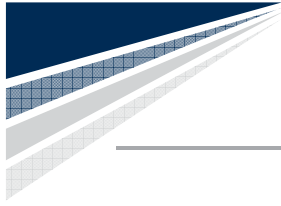

APPENDIX F
PRE-RECLAMATION CONDITION
POND ANTI-SEEP COLLAR WORKSHEET
AND OUTLET PROTECTION SIZING

Figure 5.16 Anti-Seep Collar Design

This procedure provides the anti-seep collar dimensions for only temporary sediment basins to increase the seepage length by 15% for various pipe slopes, embankment slopes and riser heights.

The first step in designing anti-seep collars is to determine the length of pipe within the saturated zone of the embankment. This can be done graphically or by the following equation, assuming that the upstream slope of the embankment intersects the invert of the pipe at its upstream end. (See embankment-invert intersection on the drawing below:

$$L_s = y (z + 4) \left[1 + \frac{\text{pipe slope}}{0.25 - \text{pipe slope}} \right] \quad \begin{array}{l} L_s = \\ 6.4(2.5+4)(1+(0.0085/(0.25-0.0085))) \\ = 42.4 \text{ ft} \end{array}$$

Where: L_s = length of pipe in the saturated zone (ft.)

y = distance in feet from upstream invert of pipe to highest normal water level expected to occur during the life of the structure, usually the top of the riser. 838.4 - 832 = 6.4

z = slope of upstream embankment as a ratio of z ft. horizontal to one ft. vertical. 2.5

pipe slope = slope of pipe in feet per foot. 0.0085

This procedure is based on the approximation of the phreatic line as shown in the drawing below:

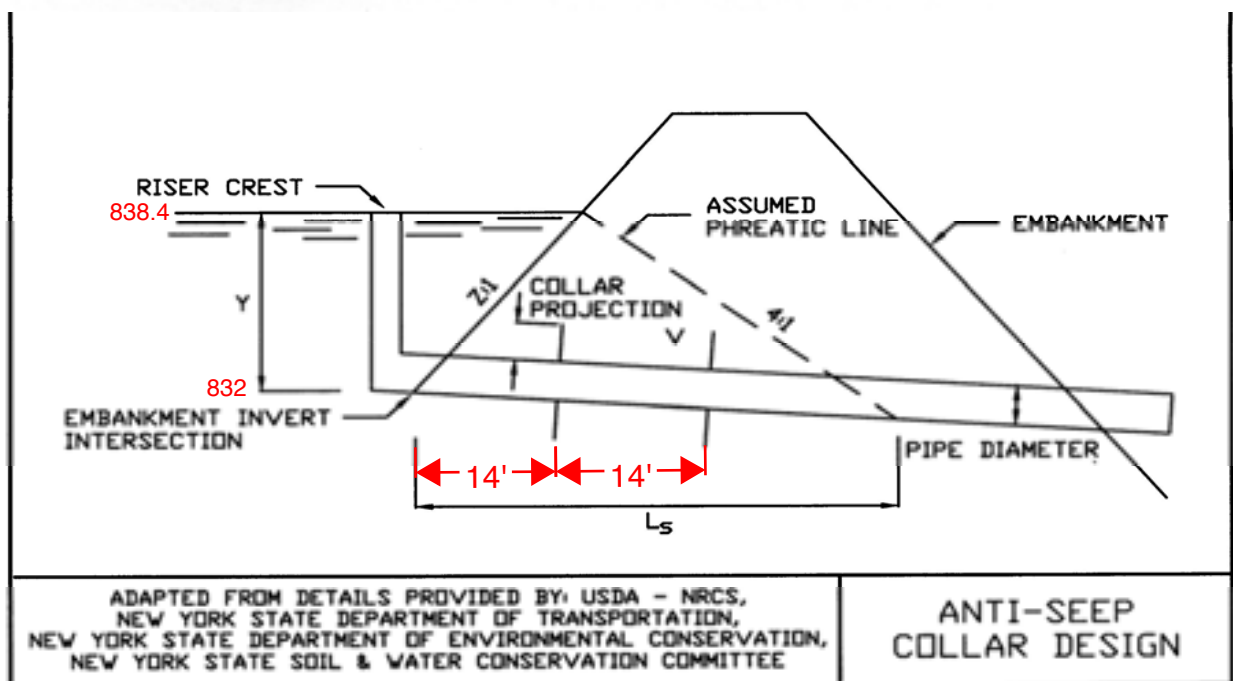

Figure 5.17
Anti-Seep Collar Design Charts (USDA - NRCS)

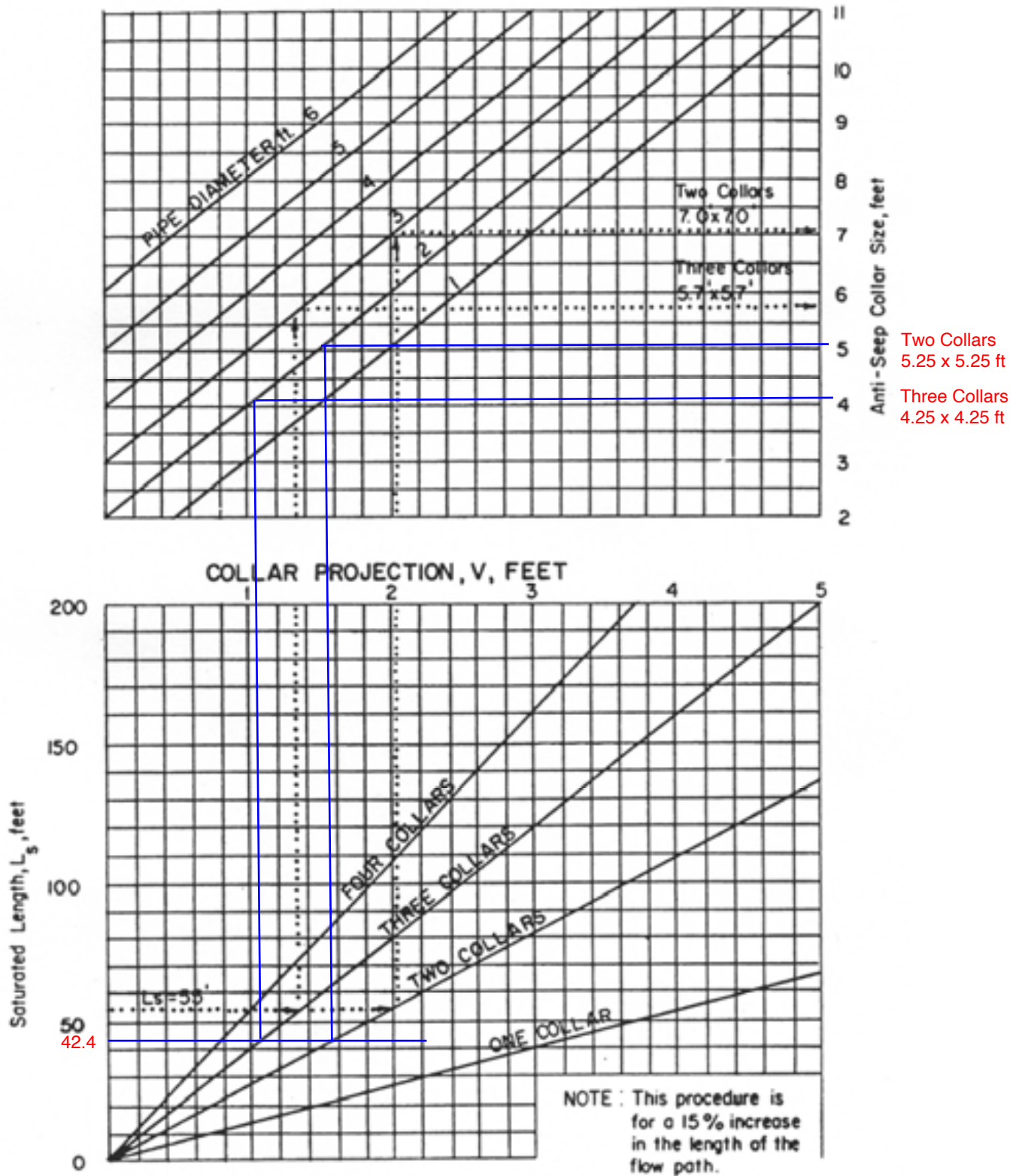
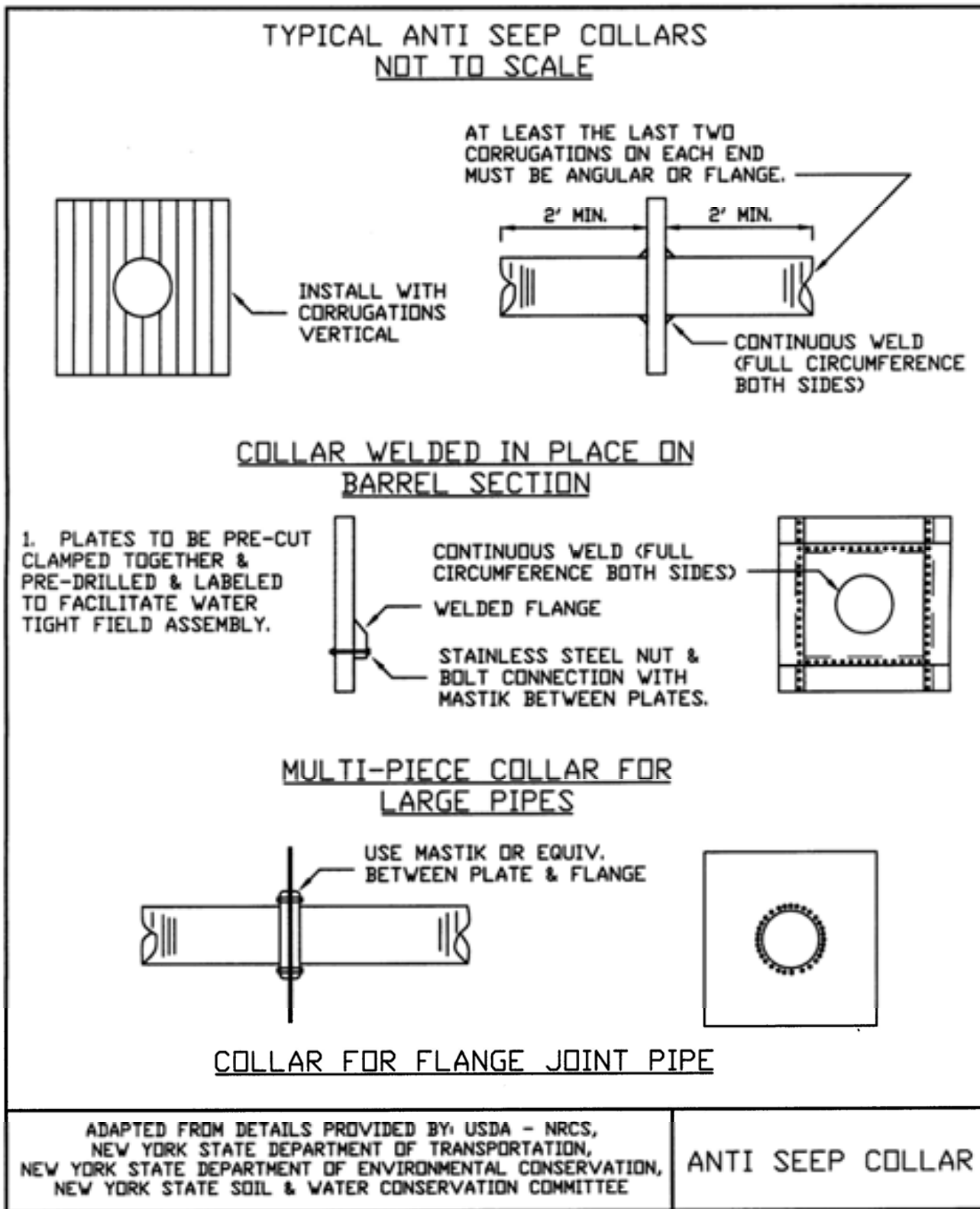

Figure 5.18
Anti-Seep Collar



DESIGN OF OUTLET PROTECTION
MINIMUM TAILWATER CONDITION ($T_w < 0.5$ diam.)

Median stone diameter, d_{50} , is the stone size which 50% of the riprap mixture, by weight, is larger than.
 Velocities shown are for pipes flowing full.

$W = \text{diam.} + L_a$

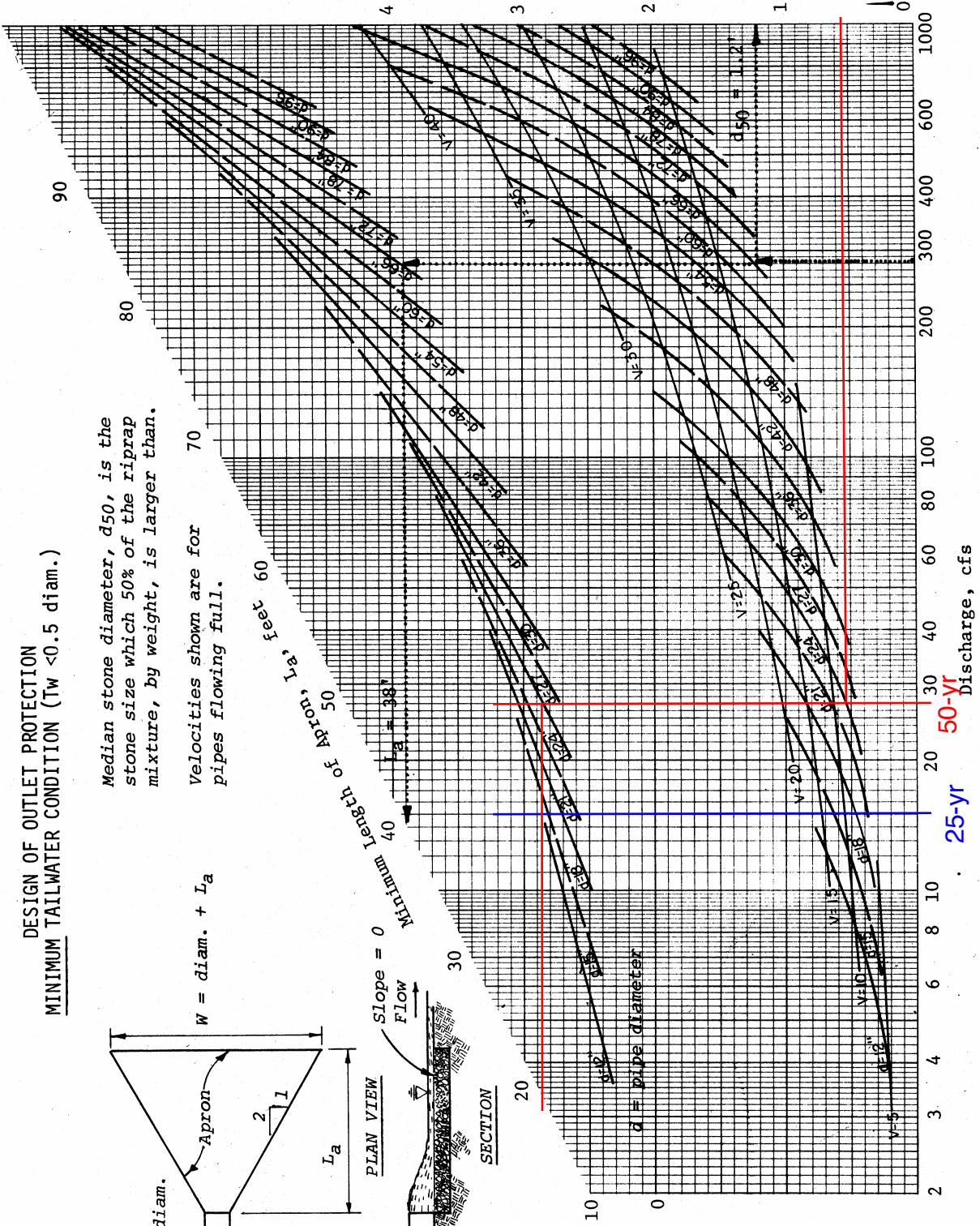
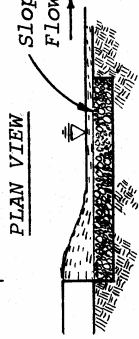
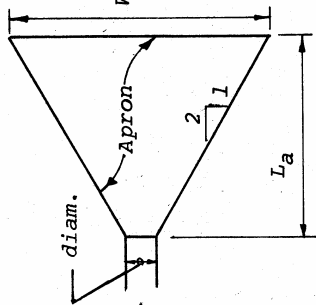

well-graded mixture, as used herein, is defined as a mixture composed primarily of larger rock sizes, but with a sufficient mixture of other sizes to fill the smaller voids between the rocks. The diameter of the largest rock size in such a mixture shall be 1.5 times the d_{50} size.

Thickness

The minimum thickness of the riprap layer shall be 1.5 times the maximum rock diameter for d_{50} of 15 inches or less; and 1.2 times the maximum rock size for d_{50} greater than 15 inches. The following chart lists some examples:

D_{50} (inches)	d_{max} (inches)	Minimum Blanket Thick- ness (inches)
4	6	9
6	9	14
9	14	20
12	18	27
15	22	32
18	27	32
21	32	38
24	36	43

Rock Quality

Rock for riprap shall consist of field rock or rough unhewn quarry rock. The rock shall be hard and angular and of a quality that will not disintegrate on exposure to water or weathering. The specific gravity of the individual rocks shall be at least 2.5.

Filter

A filter is a layer of material placed between the riprap and the underlying soil surface to prevent soil movement into and through the riprap. Riprap shall have a filter placed under it in all cases.

A filter can be of two general forms: a gravel layer or a plastic filter cloth. The plastic filter cloth can be woven or non-woven monofilament yarns, and shall meet these base requirements: thickness 20-60 mils, grab strength 90-120 lbs; and shall conform to ASTM D-1777 and ASTM D-1682.

Gravel filter blanket, when used, shall be designed by comparing particle sizes of the overlying material and the base material. Design criteria are available in Standard and Specification for Anchored Slope and Channel Stabilization on page 4.7.

Gabions

Gabions shall be made of hexagonal triple twist mesh with heavily galvanized steel wire. The maximum linear dimension of the mesh opening shall not exceed 4 ½ inches and the area of the mesh opening shall not exceed 10 square inches.

Gabions shall be fabricated in such a manner that the sides, ends, and lid can be assembled at the construction site into a rectangular basket of the specified sizes. Gabions shall be of single unit construction and shall be installed according to manufacturer's recommendations.

The area on which the gabion is to be installed shall be graded as shown on the drawings. Foundation conditions shall be the same as for placing rock riprap, and filter cloth shall be placed under all gabions. Where necessary, key, or tie, the structure into the bank to prevent undermining of the main gabion structure.

Maintenance

Once a riprap outlet has been installed, the maintenance needs are very low. It should be inspected after high flows for evidence of scour beneath the riprap or for dislodged rocks. Repairs should be made immediately.

Design Procedure

1. Investigate the downstream channel to assure that nonerosive velocities can be maintained.
2. Determine the tailwater condition at the outlet to establish which curve to use.
3. Use the appropriate chart with the design discharge to determine the riprap size and apron length required. It is noted that references to pipe diameters in the charts are based on full flow. For other than full pipe flow, the parameters of depth of flow and velocity must be used to adjust the design discharges.
4. Calculate apron width at the downstream end if a flare section is to be employed.

Design Examples are demonstrated in Appendix B.

Construction Specifications

1. The subgrade for the filter, riprap, or gabion shall be prepared to the required lines and grades. Any fill required in the subgrade shall be compacted to a density of approximately that of the surrounding undisturbed material.
2. The rock or gravel shall conform to the specified grad-

**Figure 3.18
Riprap Outlet Protection Detail (1)**

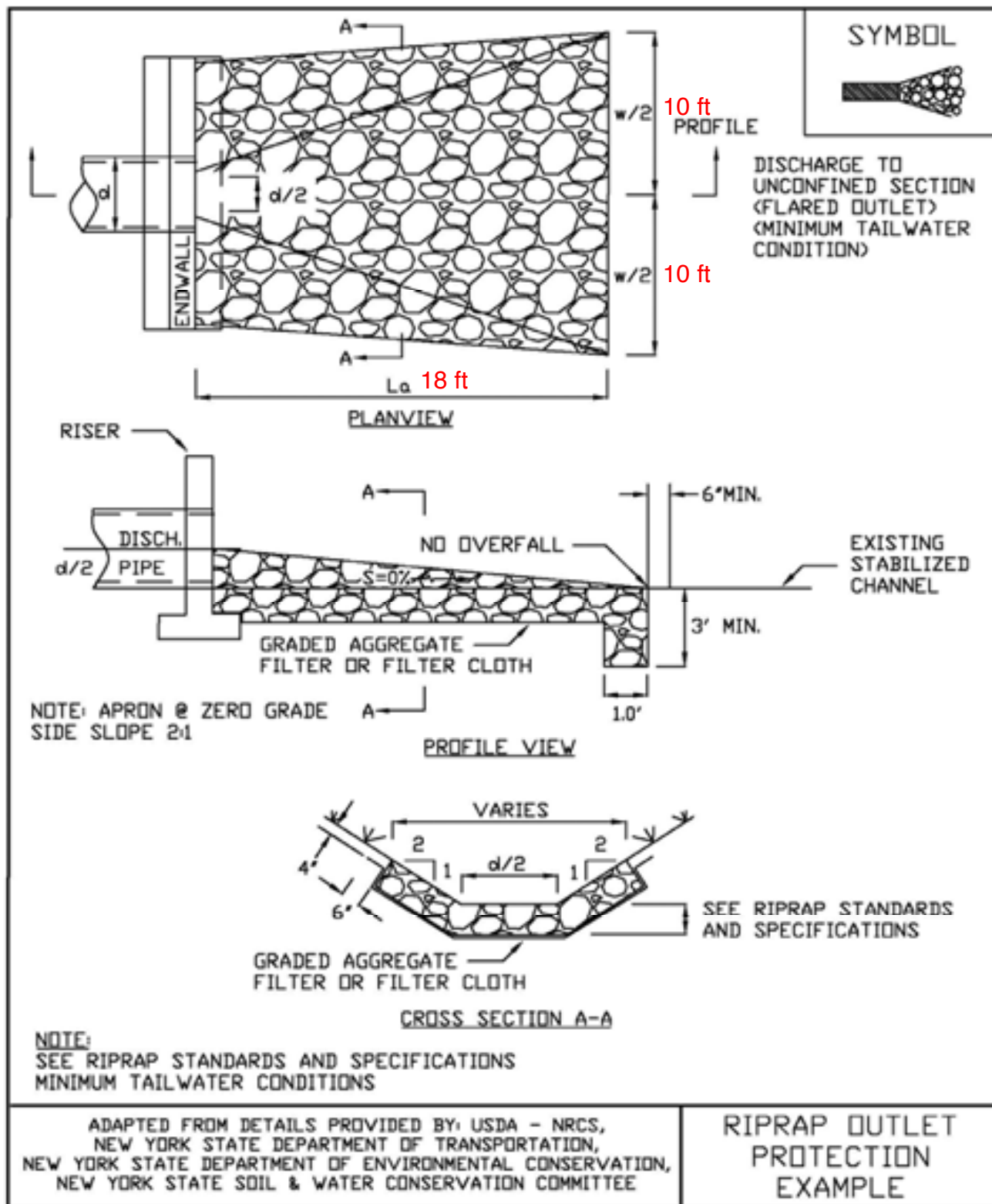



APPENDIX G

HYDROCAD MODEL REPORTS

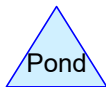
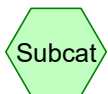
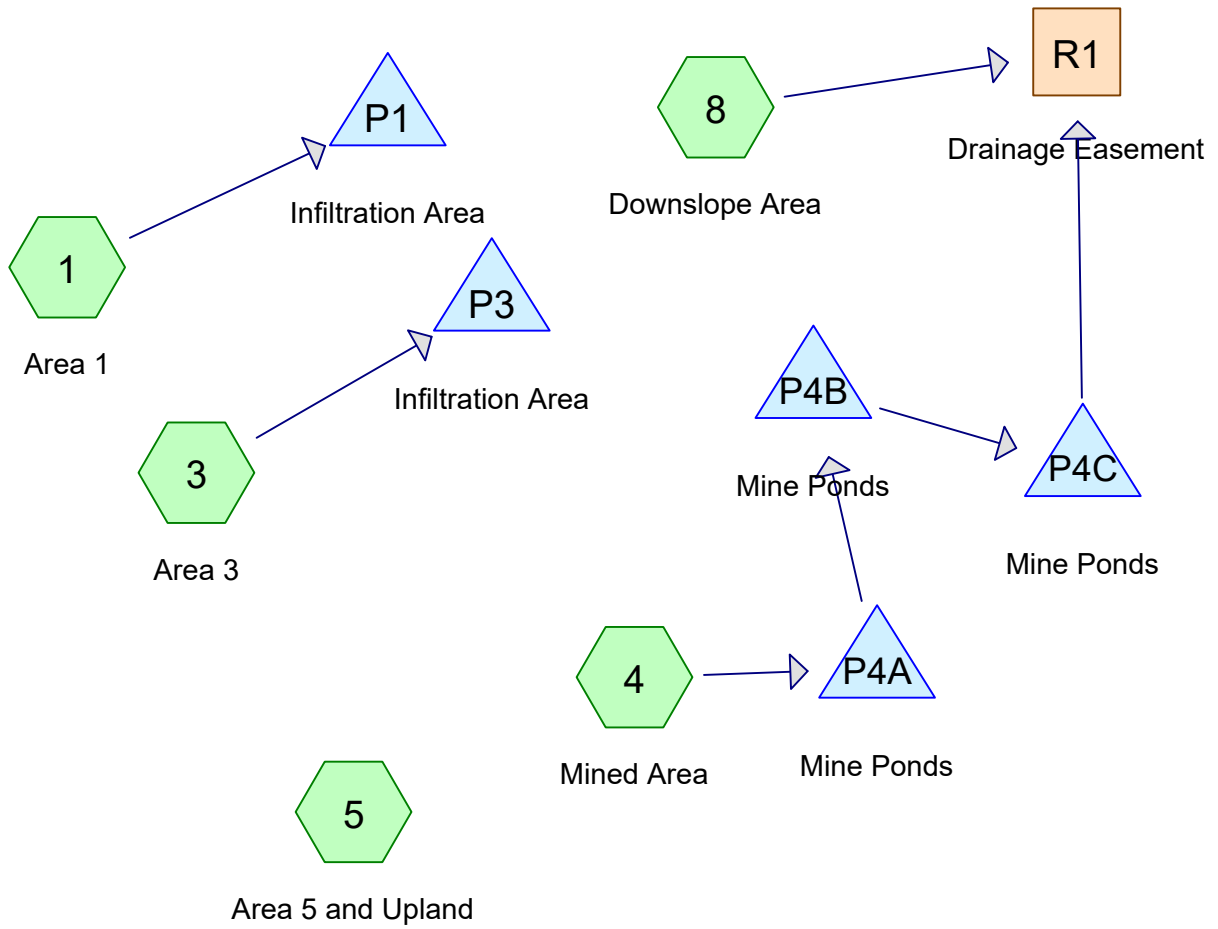

IGN Padua Ridge Existing v4 w culvert

Prepared by JMT

HydroCAD® 10.00-20 s/n 02102 © 2017 HydroCAD Software Solutions LLC

Printed 1/31/2022

Page 2

Area Listing (all nodes)

Area (acres)	CN	Description (subcatchment-numbers)
3.119	85	Gravel roads, HSG B (1, 3, 8)
17.838	77	Newly graded area, HSG A (4)
18.760	39	Pasture/grassland/range, Good, HSG A (5)
0.581	98	Water Surface, HSG A (4)
31.062	30	Woods, Good, HSG A (1, 3, 5)
5.149	32	Woods/grass comb., Good, HSG A (8)
7.922	58	Woods/grass comb., Good, HSG B (1, 3, 8)
20.309	79	Woods/grass comb., Good, HSG D (8)
104.740	53	TOTAL AREA

IGN Padua Ridge Existing v4 w culvert

Prepared by JMT

HydroCAD® 10.00-20 s/n 02102 © 2017 HydroCAD Software Solutions LLC

Printed 1/31/2022

Page 3

Soil Listing (all nodes)

Area (acres)	Soil Group	Subcatchment Numbers
73.390	HSG A	1, 3, 4, 5, 8
11.040	HSG B	1, 3, 8
0.000	HSG C	
20.309	HSG D	8
0.000	Other	
104.740		TOTAL AREA

IGN Padua Ridge Existing v4 w culvert

Prepared by JMT

HydroCAD® 10.00-20 s/n 02102 © 2017 HydroCAD Software Solutions LLC

Printed 1/31/2022

Page 4

Ground Covers (all nodes)

HSG-A (acres)	HSG-B (acres)	HSG-C (acres)	HSG-D (acres)	Other (acres)	Total (acres)	Ground Cover	Subcatchment Numbers
0.000	3.119	0.000	0.000	0.000	3.119	Gravel roads	1, 3, 8
17.838	0.000	0.000	0.000	0.000	17.838	Newly graded area	4
18.760	0.000	0.000	0.000	0.000	18.760	Pasture/grassland/range, Good	5
0.581	0.000	0.000	0.000	0.000	0.581	Water Surface	4
31.062	0.000	0.000	0.000	0.000	31.062	Woods, Good	1, 3, 5
5.149	7.922	0.000	20.309	0.000	33.380	Woods/grass comb., Good	1, 3, 8
73.390	11.040	0.000	20.309	0.000	104.740	TOTAL AREA	

IGN Padua Ridge Existing v4 w culvert

Prepared by JMT

HydroCAD® 10.00-20 s/n 02102 © 2017 HydroCAD Software Solutions LLC

Printed 1/31/2022

Page 5

Pipe Listing (all nodes)

Line#	Node Number	In-Invert (feet)	Out-Invert (feet)	Length (feet)	Slope (ft/ft)	n	Diam/Width (inches)	Height (inches)	Inside-Fill (inches)
1	P4C	832.00	831.00	118.0	0.0085	0.012	24.0	0.0	0.0

IGN Padua Ridge Existing v4 w culvert

Type II 24-hr 10-yr Rainfall=3.61"

Prepared by JMT

Printed 1/31/2022

HydroCAD® 10.00-20 s/n 02102 © 2017 HydroCAD Software Solutions LLC

Page 6

Time span=0.05-120.00 hrs, dt=0.05 hrs, 2400 points
 Runoff by SCS TR-20 method, UH=SCS, Weighted-CN
 Reach routing by Stor-Ind+Trans method - Pond routing by Stor-Ind method

Subcatchment1: Area 1 Runoff Area=292,726 sf 0.00% Impervious Runoff Depth=0.35"
 Flow Length=830' Tc=13.1 min CN=54 Runoff=1.66 cfs 0.195 af

Subcatchment3: Area 3 Runoff Area=595,060 sf 0.00% Impervious Runoff Depth=0.00"
 Flow Length=1,110' Tc=3.9 min CN=35 Runoff=0.00 cfs 0.000 af

Subcatchment4: Mined Area Runoff Area=802,323 sf 3.15% Impervious Runoff Depth=1.58"
 Flow Length=675' Tc=2.6 min CN=78 Runoff=56.88 cfs 2.427 af

Subcatchment5: Area 5 and Upland Runoff Area=35.690 ac 0.00% Impervious Runoff Depth=0.00"
 Flow Length=2,527' Tc=73.4 min CN=35 Runoff=0.00 cfs 0.000 af

Subcatchment8: Downslope Area Runoff Area=1,317,715 sf 0.00% Impervious Runoff Depth=1.02"
 Flow Length=850' Tc=17.7 min CN=69 Runoff=33.86 cfs 2.573 af

Reach R1: Drainage Easement Avg. Flow Depth=1.71' Max Vel=5.83 fps Inflow=34.47 cfs 4.999 af
 n=0.030 L=2,109.0' S=0.0166 '/' Capacity=93.64 cfs Outflow=30.09 cfs 4.999 af

Pond P1: Infiltration Area Peak Elev=855.30' Storage=3,345 cf Inflow=1.66 cfs 0.195 af
 Outflow=0.13 cfs 0.195 af

Pond P3: Infiltration Area Peak Elev=862.00' Storage=0 cf Inflow=0.00 cfs 0.000 af
 Outflow=0.00 cfs 0.000 af

Pond P4A: Mine Ponds Peak Elev=844.26' Storage=2,768 cf Inflow=56.88 cfs 2.427 af
 Outflow=56.75 cfs 2.427 af

Pond P4B: Mine Ponds Peak Elev=838.14' Storage=5,988 cf Inflow=56.75 cfs 2.427 af
 Outflow=56.46 cfs 2.427 af

Pond P4C: Mine Ponds Peak Elev=834.92' Storage=83,255 cf Inflow=56.46 cfs 2.427 af
 Outflow=1.19 cfs 2.426 af

Total Runoff Area = 104.740 ac Runoff Volume = 5.195 af Average Runoff Depth = 0.60"
99.45% Pervious = 104.159 ac 0.55% Impervious = 0.581 ac

Summary for Subcatchment 1: Area 1

Runoff = 1.66 cfs @ 12.11 hrs, Volume= 0.195 af, Depth= 0.35"

Runoff by SCS TR-20 method, UH=SCS, Weighted-CN, Time Span= 0.05-120.00 hrs, dt= 0.05 hrs
 Type II 24-hr 10-yr Rainfall=3.61"

Area (sf)	CN	Description
50,010	85	Gravel roads, HSG B
151,324	58	Woods/grass comb., Good, HSG B
91,392	30	Woods, Good, HSG A
292,726	54	Weighted Average
292,726		100.00% Pervious Area

Tc (min)	Length (feet)	Slope (ft/ft)	Velocity (ft/sec)	Capacity (cfs)	Description
8.5	100	0.3000	0.20		Sheet Flow, Woods: Light underbrush n= 0.400 P2= 2.35"
3.1	372	0.1600	2.00		Shallow Concentrated Flow, Woodland Kv= 5.0 fps
1.5	358	0.0600	3.94		Shallow Concentrated Flow, Unpaved Kv= 16.1 fps
13.1	830	Total			

Subcatchment 1: Area 1

Hydrograph

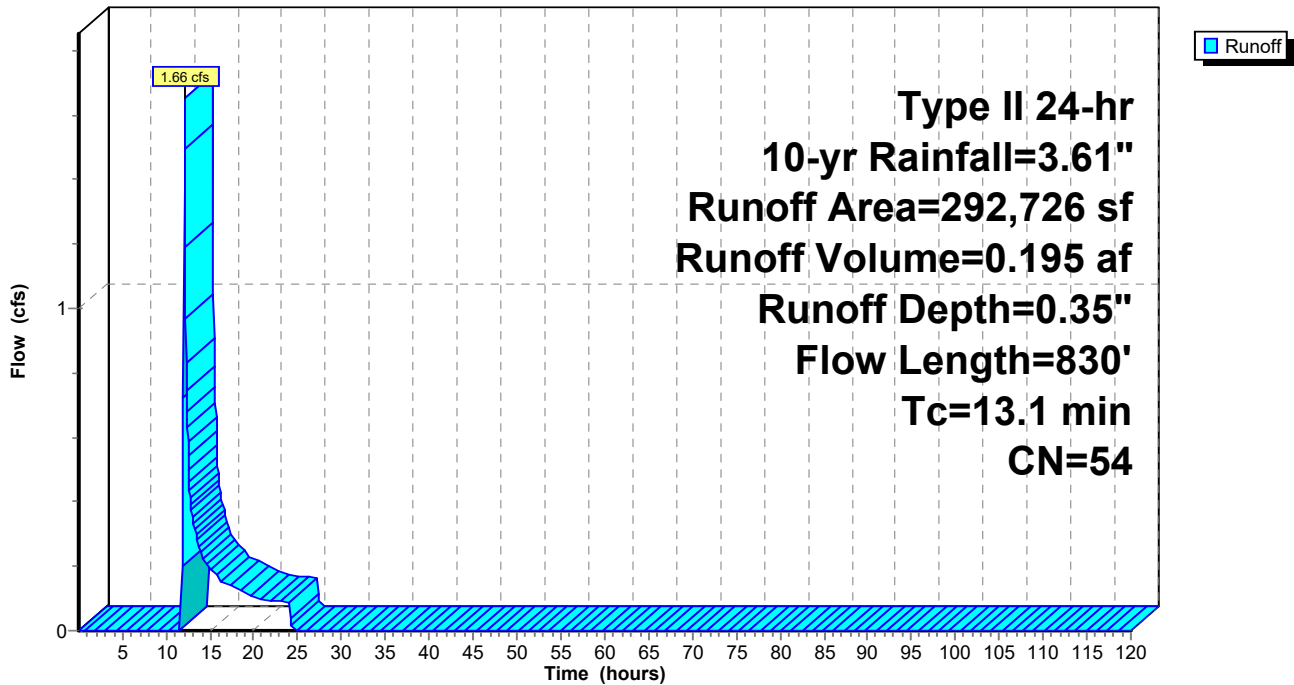

IGN Padua Ridge Existing v4 w culvert

Type II 24-hr 10-yr Rainfall=3.61"

Prepared by JMT

Printed 1/31/2022

HydroCAD® 10.00-20 s/n 02102 © 2017 HydroCAD Software Solutions LLC

Page 8

Hydrograph for Subcatchment 1: Area 1

Time (hours)	Precip. (inches)	Excess (inches)	Runoff (cfs)
0.05	0.00	0.00	0.00
2.55	0.10	0.00	0.00
5.05	0.23	0.00	0.00
7.55	0.40	0.00	0.00
10.05	0.66	0.00	0.00
12.55	2.67	0.10	0.54
15.05	3.09	0.19	0.19
17.55	3.29	0.25	0.14
20.05	3.44	0.29	0.10
22.55	3.55	0.33	0.09
25.05	3.61	0.35	0.00
27.55	3.61	0.35	0.00
30.05	3.61	0.35	0.00
32.55	3.61	0.35	0.00
35.05	3.61	0.35	0.00
37.55	3.61	0.35	0.00
40.05	3.61	0.35	0.00
42.55	3.61	0.35	0.00
45.05	3.61	0.35	0.00
47.55	3.61	0.35	0.00
50.05	3.61	0.35	0.00
52.55	3.61	0.35	0.00
55.05	3.61	0.35	0.00
57.55	3.61	0.35	0.00
60.05	3.61	0.35	0.00
62.55	3.61	0.35	0.00
65.05	3.61	0.35	0.00
67.55	3.61	0.35	0.00
70.05	3.61	0.35	0.00
72.55	3.61	0.35	0.00
75.05	3.61	0.35	0.00
77.55	3.61	0.35	0.00
80.05	3.61	0.35	0.00
82.55	3.61	0.35	0.00
85.05	3.61	0.35	0.00
87.55	3.61	0.35	0.00
90.05	3.61	0.35	0.00
92.55	3.61	0.35	0.00
95.05	3.61	0.35	0.00
97.55	3.61	0.35	0.00
100.05	3.61	0.35	0.00
102.55	3.61	0.35	0.00
105.05	3.61	0.35	0.00
107.55	3.61	0.35	0.00
110.05	3.61	0.35	0.00
112.55	3.61	0.35	0.00
115.05	3.61	0.35	0.00
117.55	3.61	0.35	0.00

Summary for Subcatchment 3: Area 3

Runoff = 0.00 cfs @ 0.05 hrs, Volume= 0.000 af, Depth= 0.00"

Runoff by SCS TR-20 method, UH=SCS, Weighted-CN, Time Span= 0.05-120.00 hrs, dt= 0.05 hrs
 Type II 24-hr 10-yr Rainfall=3.61"

Area (sf)	CN	Description
45,301	85	Gravel roads, HSG B
25,552	58	Woods/grass comb., Good, HSG B
524,207	30	Woods, Good, HSG A
595,060	35	Weighted Average
595,060		100.00% Pervious Area

Tc (min)	Length (feet)	Slope (ft/ft)	Velocity (ft/sec)	Capacity (cfs)	Description
0.7	100	0.1000	2.24		Sheet Flow, Smooth surfaces n= 0.011 P2= 2.35"
3.2	1,010	0.1100	5.34		Shallow Concentrated Flow, Unpaved Kv= 16.1 fps
3.9	1,110	Total			

Subcatchment 3: Area 3

Hydrograph

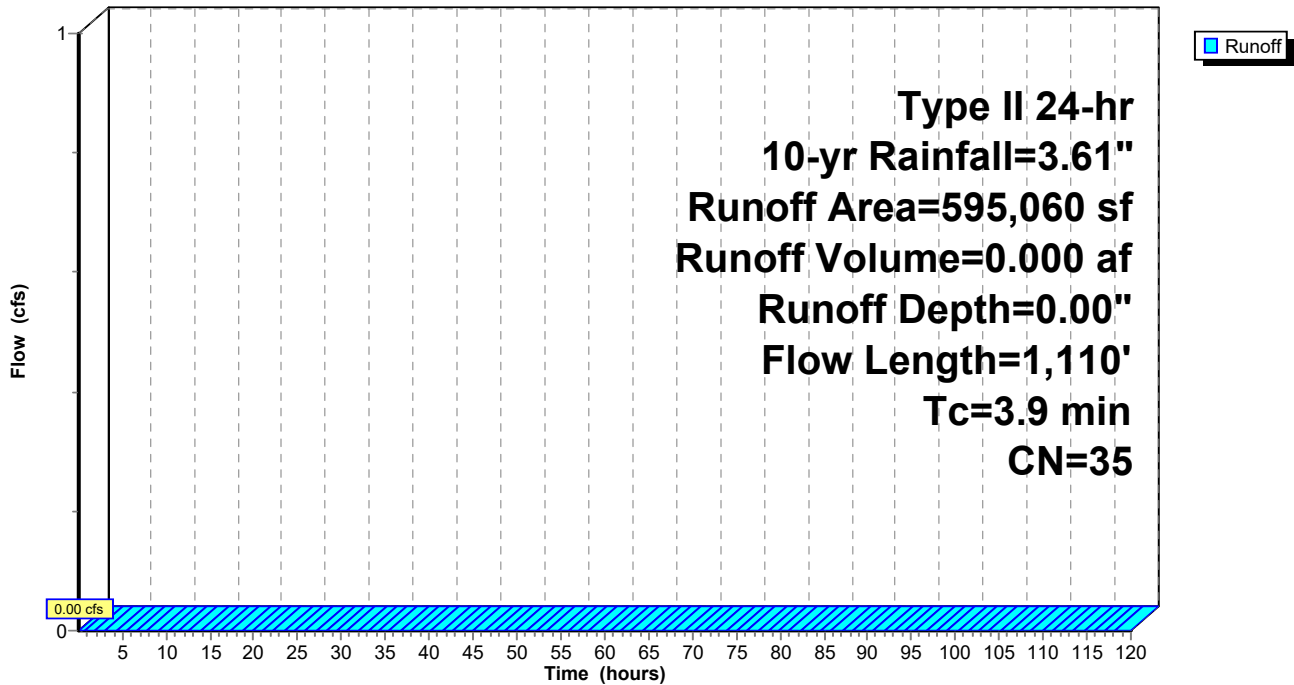

IGN Padua Ridge Existing v4 w culvert*Type II 24-hr 10-yr Rainfall=3.61"*

Prepared by JMT

Printed 1/31/2022

HydroCAD® 10.00-20 s/n 02102 © 2017 HydroCAD Software Solutions LLC

Page 10

Hydrograph for Subcatchment 3: Area 3

Time (hours)	Precip. (inches)	Excess (inches)	Runoff (cfs)
0.05	0.00	0.00	0.00
2.55	0.10	0.00	0.00
5.05	0.23	0.00	0.00
7.55	0.40	0.00	0.00
10.05	0.66	0.00	0.00
12.55	2.67	0.00	0.00
15.05	3.09	0.00	0.00
17.55	3.29	0.00	0.00
20.05	3.44	0.00	0.00
22.55	3.55	0.00	0.00
25.05	3.61	0.00	0.00
27.55	3.61	0.00	0.00
30.05	3.61	0.00	0.00
32.55	3.61	0.00	0.00
35.05	3.61	0.00	0.00
37.55	3.61	0.00	0.00
40.05	3.61	0.00	0.00
42.55	3.61	0.00	0.00
45.05	3.61	0.00	0.00
47.55	3.61	0.00	0.00
50.05	3.61	0.00	0.00
52.55	3.61	0.00	0.00
55.05	3.61	0.00	0.00
57.55	3.61	0.00	0.00
60.05	3.61	0.00	0.00
62.55	3.61	0.00	0.00
65.05	3.61	0.00	0.00
67.55	3.61	0.00	0.00
70.05	3.61	0.00	0.00
72.55	3.61	0.00	0.00
75.05	3.61	0.00	0.00
77.55	3.61	0.00	0.00
80.05	3.61	0.00	0.00
82.55	3.61	0.00	0.00
85.05	3.61	0.00	0.00
87.55	3.61	0.00	0.00
90.05	3.61	0.00	0.00
92.55	3.61	0.00	0.00
95.05	3.61	0.00	0.00
97.55	3.61	0.00	0.00
100.05	3.61	0.00	0.00
102.55	3.61	0.00	0.00
105.05	3.61	0.00	0.00
107.55	3.61	0.00	0.00
110.05	3.61	0.00	0.00
112.55	3.61	0.00	0.00
115.05	3.61	0.00	0.00
117.55	3.61	0.00	0.00

IGN Padua Ridge Existing v4 w culvert

Type II 24-hr 10-yr Rainfall=3.61"

Prepared by JMT

Printed 1/31/2022

HydroCAD® 10.00-20 s/n 02102 © 2017 HydroCAD Software Solutions LLC

Page 11

Summary for Subcatchment 4: Mined Area

Runoff = 56.88 cfs @ 11.93 hrs, Volume= 2.427 af, Depth= 1.58"

Runoff by SCS TR-20 method, UH=SCS, Weighted-CN, Time Span= 0.05-120.00 hrs, dt= 0.05 hrs
Type II 24-hr 10-yr Rainfall=3.61"

Area (sf)	CN	Description
777,023	77	Newly graded area, HSG A
25,300	98	Water Surface, HSG A
802,323	78	Weighted Average
777,023		96.85% Pervious Area
25,300		3.15% Impervious Area

Tc (min)	Length (feet)	Slope (ft/ft)	Velocity (ft/sec)	Capacity (cfs)	Description
0.4	100	0.3500	3.70		Sheet Flow, Smooth surfaces n= 0.011 P2= 2.35"
0.2	135	0.3300	9.25		Shallow Concentrated Flow, Unpaved Kv= 16.1 fps
1.7	290	0.0300	2.79		Shallow Concentrated Flow, Unpaved Kv= 16.1 fps
0.3	150	0.2700	8.37		Shallow Concentrated Flow, Unpaved Kv= 16.1 fps
2.6	675	Total			

Subcatchment 4: Mined Area

Hydrograph

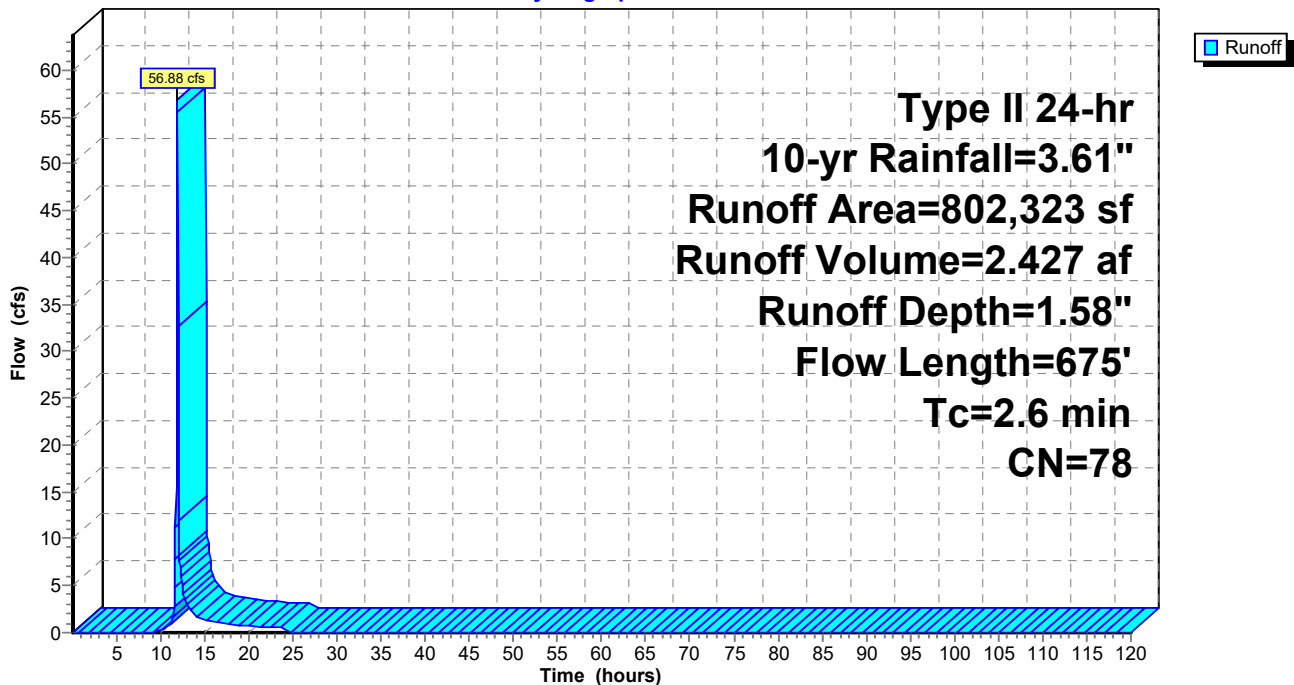

IGN Padua Ridge Existing v4 w culvert

Type II 24-hr 10-yr Rainfall=3.61"

Prepared by JMT

Printed 1/31/2022

HydroCAD® 10.00-20 s/n 02102 © 2017 HydroCAD Software Solutions LLC

Page 12

Hydrograph for Subcatchment 4: Mined Area

Time (hours)	Precip. (inches)	Excess (inches)	Runoff (cfs)
0.05	0.00	0.00	0.00
2.55	0.10	0.00	0.00
5.05	0.23	0.00	0.00
7.55	0.40	0.00	0.00
10.05	0.66	0.00	0.17
12.55	2.67	0.90	3.93
15.05	3.09	1.19	1.45
17.55	3.29	1.34	0.96
20.05	3.44	1.45	0.66
22.55	3.55	1.54	0.60
25.05	3.61	1.58	0.00
27.55	3.61	1.58	0.00
30.05	3.61	1.58	0.00
32.55	3.61	1.58	0.00
35.05	3.61	1.58	0.00
37.55	3.61	1.58	0.00
40.05	3.61	1.58	0.00
42.55	3.61	1.58	0.00
45.05	3.61	1.58	0.00
47.55	3.61	1.58	0.00
50.05	3.61	1.58	0.00
52.55	3.61	1.58	0.00
55.05	3.61	1.58	0.00
57.55	3.61	1.58	0.00
60.05	3.61	1.58	0.00
62.55	3.61	1.58	0.00
65.05	3.61	1.58	0.00
67.55	3.61	1.58	0.00
70.05	3.61	1.58	0.00
72.55	3.61	1.58	0.00
75.05	3.61	1.58	0.00
77.55	3.61	1.58	0.00
80.05	3.61	1.58	0.00
82.55	3.61	1.58	0.00
85.05	3.61	1.58	0.00
87.55	3.61	1.58	0.00
90.05	3.61	1.58	0.00
92.55	3.61	1.58	0.00
95.05	3.61	1.58	0.00
97.55	3.61	1.58	0.00
100.05	3.61	1.58	0.00
102.55	3.61	1.58	0.00
105.05	3.61	1.58	0.00
107.55	3.61	1.58	0.00
110.05	3.61	1.58	0.00
112.55	3.61	1.58	0.00
115.05	3.61	1.58	0.00
117.55	3.61	1.58	0.00

Summary for Subcatchment 5: Area 5 and Upland

Runoff = 0.00 cfs @ 0.05 hrs, Volume= 0.000 af, Depth= 0.00"

Runoff by SCS TR-20 method, UH=SCS, Weighted-CN, Time Span= 0.05-120.00 hrs, dt= 0.05 hrs
 Type II 24-hr 10-yr Rainfall=3.61"

Area (ac)	CN	Description
18.760	39	Pasture/grassland/range, Good, HSG A
16.930	30	Woods, Good, HSG A
35.690	35	Weighted Average
35.690		100.00% Pervious Area

Tc (min)	Length (feet)	Slope (ft/ft)	Velocity (ft/sec)	Capacity (cfs)	Description
16.1	100	0.0600	0.10		Sheet Flow, Woods: Light underbrush n= 0.400 P2= 2.35"
46.5	1,972	0.0200	0.71		Shallow Concentrated Flow, Woodland Kv= 5.0 fps
10.8	455	0.0100	0.70		Shallow Concentrated Flow, Short Grass Pasture Kv= 7.0 fps
73.4	2,527	Total			

Subcatchment 5: Area 5 and Upland

Hydrograph

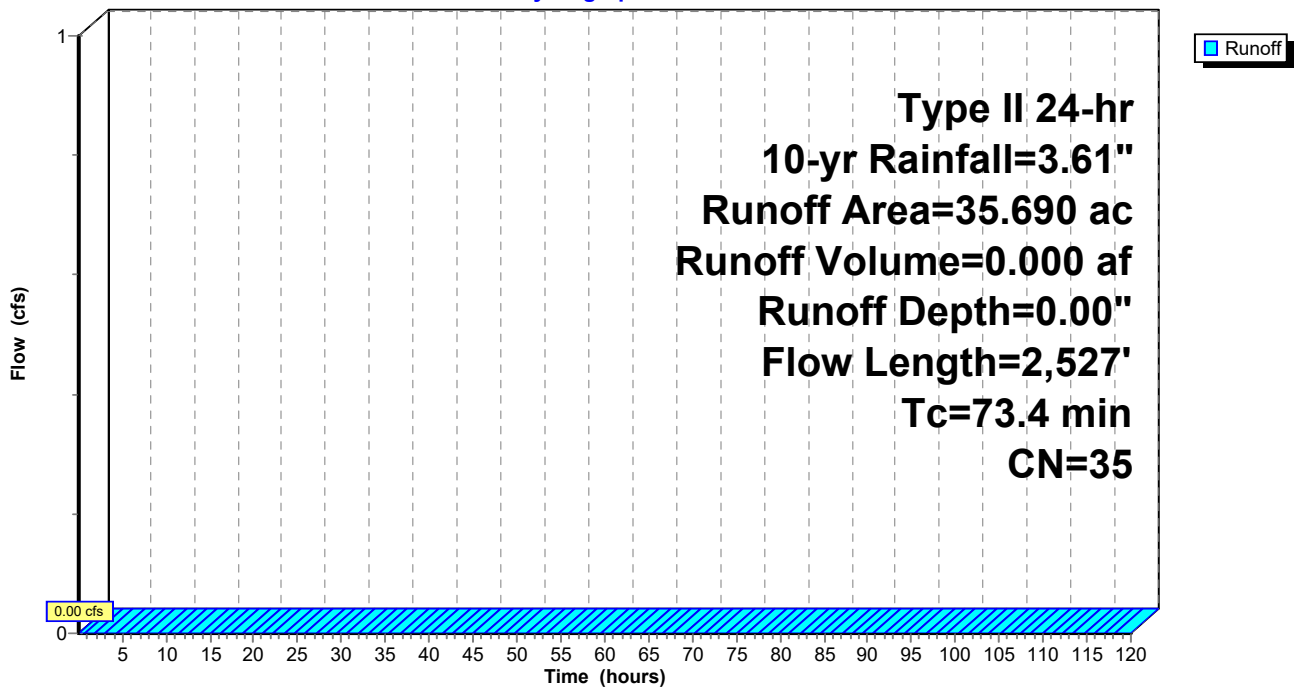

IGN Padua Ridge Existing v4 w culvert*Type II 24-hr 10-yr Rainfall=3.61"*

Prepared by JMT

Printed 1/31/2022

HydroCAD® 10.00-20 s/n 02102 © 2017 HydroCAD Software Solutions LLC

Page 14

Hydrograph for Subcatchment 5: Area 5 and Upland

Time (hours)	Precip. (inches)	Excess (inches)	Runoff (cfs)
0.05	0.00	0.00	0.00
2.55	0.10	0.00	0.00
5.05	0.23	0.00	0.00
7.55	0.40	0.00	0.00
10.05	0.66	0.00	0.00
12.55	2.67	0.00	0.00
15.05	3.09	0.00	0.00
17.55	3.29	0.00	0.00
20.05	3.44	0.00	0.00
22.55	3.55	0.00	0.00
25.05	3.61	0.00	0.00
27.55	3.61	0.00	0.00
30.05	3.61	0.00	0.00
32.55	3.61	0.00	0.00
35.05	3.61	0.00	0.00
37.55	3.61	0.00	0.00
40.05	3.61	0.00	0.00
42.55	3.61	0.00	0.00
45.05	3.61	0.00	0.00
47.55	3.61	0.00	0.00
50.05	3.61	0.00	0.00
52.55	3.61	0.00	0.00
55.05	3.61	0.00	0.00
57.55	3.61	0.00	0.00
60.05	3.61	0.00	0.00
62.55	3.61	0.00	0.00
65.05	3.61	0.00	0.00
67.55	3.61	0.00	0.00
70.05	3.61	0.00	0.00
72.55	3.61	0.00	0.00
75.05	3.61	0.00	0.00
77.55	3.61	0.00	0.00
80.05	3.61	0.00	0.00
82.55	3.61	0.00	0.00
85.05	3.61	0.00	0.00
87.55	3.61	0.00	0.00
90.05	3.61	0.00	0.00
92.55	3.61	0.00	0.00
95.05	3.61	0.00	0.00
97.55	3.61	0.00	0.00
100.05	3.61	0.00	0.00
102.55	3.61	0.00	0.00
105.05	3.61	0.00	0.00
107.55	3.61	0.00	0.00
110.05	3.61	0.00	0.00
112.55	3.61	0.00	0.00
115.05	3.61	0.00	0.00
117.55	3.61	0.00	0.00

Summary for Subcatchment 8: Downslope Area

Runoff = 33.86 cfs @ 12.12 hrs, Volume= 2.573 af, Depth= 1.02"

Runoff by SCS TR-20 method, UH=SCS, Weighted-CN, Time Span= 0.05-120.00 hrs, dt= 0.05 hrs
Type II 24-hr 10-yr Rainfall=3.61"

Area (sf)	CN	Description
224,307	32	Woods/grass comb., Good, HSG A
168,185	58	Woods/grass comb., Good, HSG B
40,548	85	Gravel roads, HSG B
884,675	79	Woods/grass comb., Good, HSG D
1,317,715	69	Weighted Average
1,317,715		100.00% Pervious Area

Tc (min)	Length (feet)	Slope (ft/ft)	Velocity (ft/sec)	Capacity (cfs)	Description
11.2	100	0.1500	0.15		Sheet Flow, Woods: Light underbrush n= 0.400 P2= 2.35"
6.5	750	0.1460	1.91		Shallow Concentrated Flow, Woodland Kv= 5.0 fps
17.7	850	Total			

Subcatchment 8: Downslope Area

Hydrograph

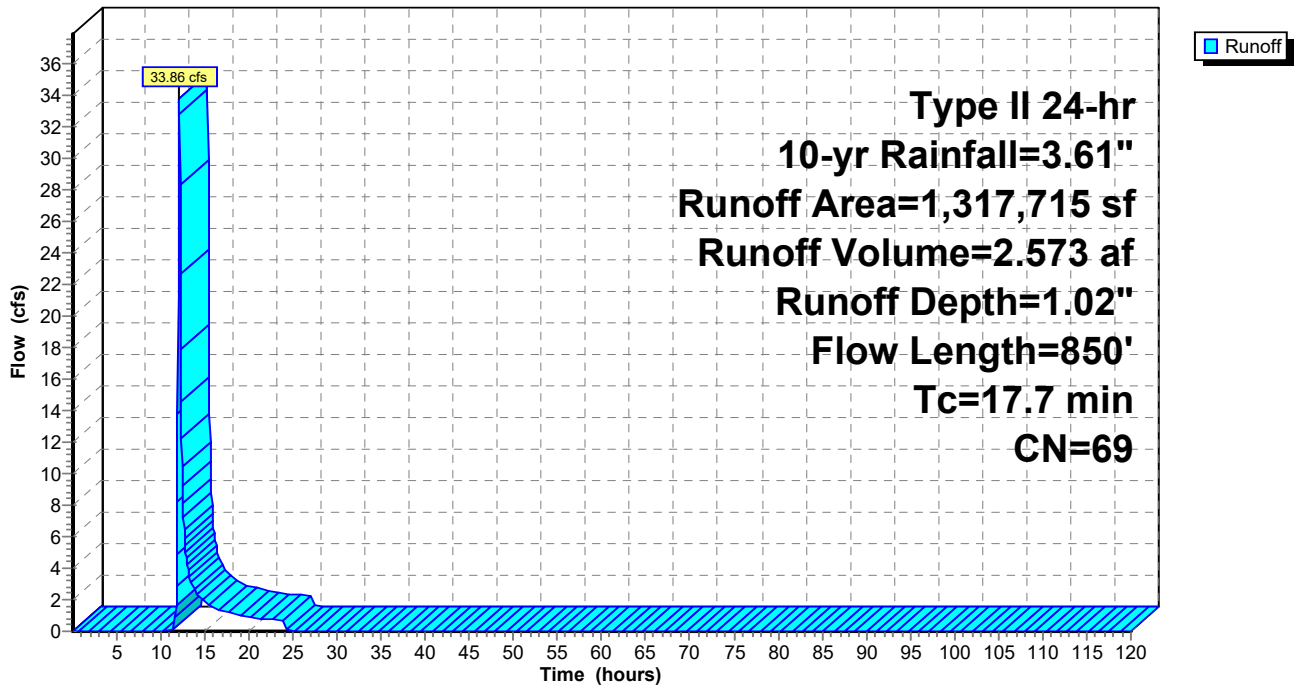

IGN Padua Ridge Existing v4 w culvert

Type II 24-hr 10-yr Rainfall=3.61"

Prepared by JMT

Printed 1/31/2022

HydroCAD® 10.00-20 s/n 02102 © 2017 HydroCAD Software Solutions LLC

Page 16

Hydrograph for Subcatchment 8: Downslope Area

Time (hours)	Precip. (inches)	Excess (inches)	Runoff (cfs)
0.05	0.00	0.00	0.00
2.55	0.10	0.00	0.00
5.05	0.23	0.00	0.00
7.55	0.40	0.00	0.00
10.05	0.66	0.00	0.00
12.55	2.67	0.50	8.12
15.05	3.09	0.72	1.89
17.55	3.29	0.83	1.25
20.05	3.44	0.92	0.88
22.55	3.55	0.98	0.79
25.05	3.61	1.02	0.00
27.55	3.61	1.02	0.00
30.05	3.61	1.02	0.00
32.55	3.61	1.02	0.00
35.05	3.61	1.02	0.00
37.55	3.61	1.02	0.00
40.05	3.61	1.02	0.00
42.55	3.61	1.02	0.00
45.05	3.61	1.02	0.00
47.55	3.61	1.02	0.00
50.05	3.61	1.02	0.00
52.55	3.61	1.02	0.00
55.05	3.61	1.02	0.00
57.55	3.61	1.02	0.00
60.05	3.61	1.02	0.00
62.55	3.61	1.02	0.00
65.05	3.61	1.02	0.00
67.55	3.61	1.02	0.00
70.05	3.61	1.02	0.00
72.55	3.61	1.02	0.00
75.05	3.61	1.02	0.00
77.55	3.61	1.02	0.00
80.05	3.61	1.02	0.00
82.55	3.61	1.02	0.00
85.05	3.61	1.02	0.00
87.55	3.61	1.02	0.00
90.05	3.61	1.02	0.00
92.55	3.61	1.02	0.00
95.05	3.61	1.02	0.00
97.55	3.61	1.02	0.00
100.05	3.61	1.02	0.00
102.55	3.61	1.02	0.00
105.05	3.61	1.02	0.00
107.55	3.61	1.02	0.00
110.05	3.61	1.02	0.00
112.55	3.61	1.02	0.00
115.05	3.61	1.02	0.00
117.55	3.61	1.02	0.00

Summary for Reach R1: Drainage Easement

Inflow Area = 48.669 ac, 1.19% Impervious, Inflow Depth = 1.23" for 10-yr event
 Inflow = 34.47 cfs @ 12.12 hrs, Volume= 4.999 af
 Outflow = 30.09 cfs @ 12.29 hrs, Volume= 4.999 af, Atten= 13%, Lag= 10.5 min

Routing by Stor-Ind+Trans method, Time Span= 0.05-120.00 hrs, dt= 0.05 hrs
 Max. Velocity= 5.83 fps, Min. Travel Time= 6.0 min
 Avg. Velocity = 1.28 fps, Avg. Travel Time= 27.6 min

Peak Storage= 10,881 cf @ 12.19 hrs
 Average Depth at Peak Storage= 1.71'
 Bank-Full Depth= 3.00' Flow Area= 12.0 sf, Capacity= 93.64 cfs

6.00' x 3.00' deep Parabolic Channel, n= 0.030 Earth, grassed & winding
 Length= 2,109.0' Slope= 0.0166 '/'
 Inlet Invert= 780.00', Outlet Invert= 745.00'

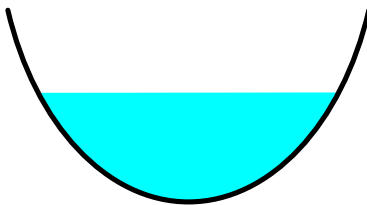

Reach R1: Drainage Easement

Hydrograph

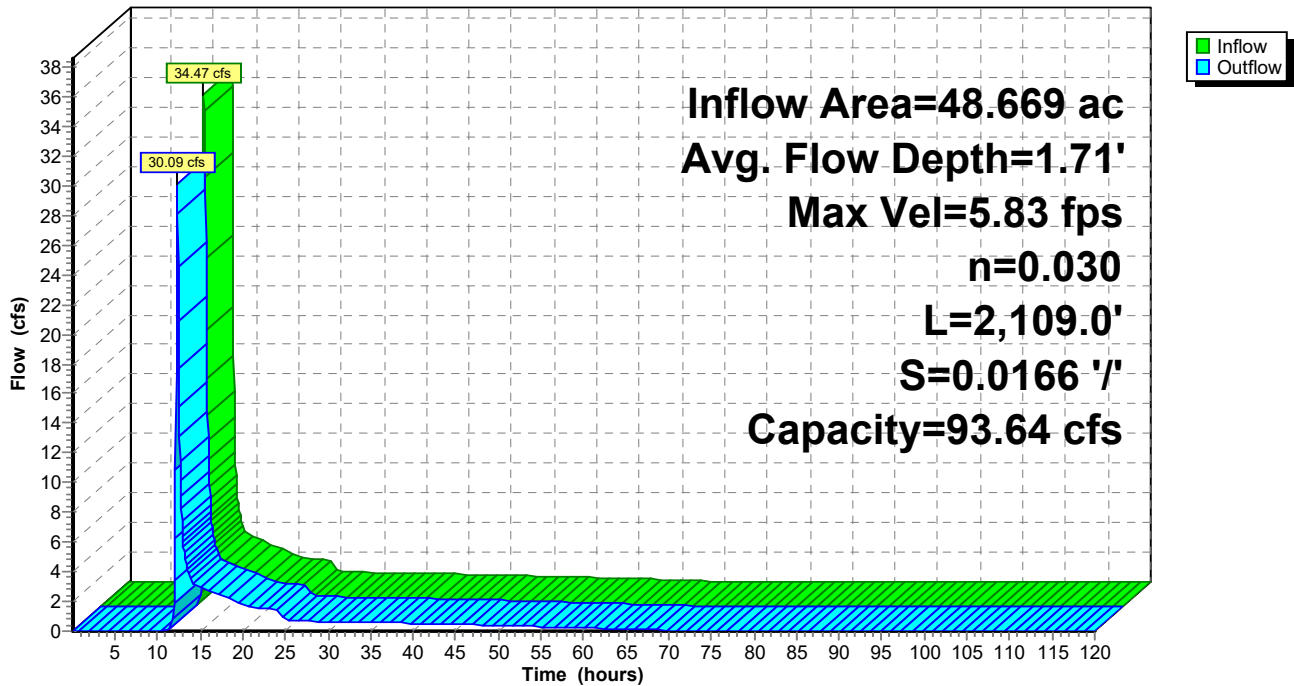

Reach R1: Drainage Easement

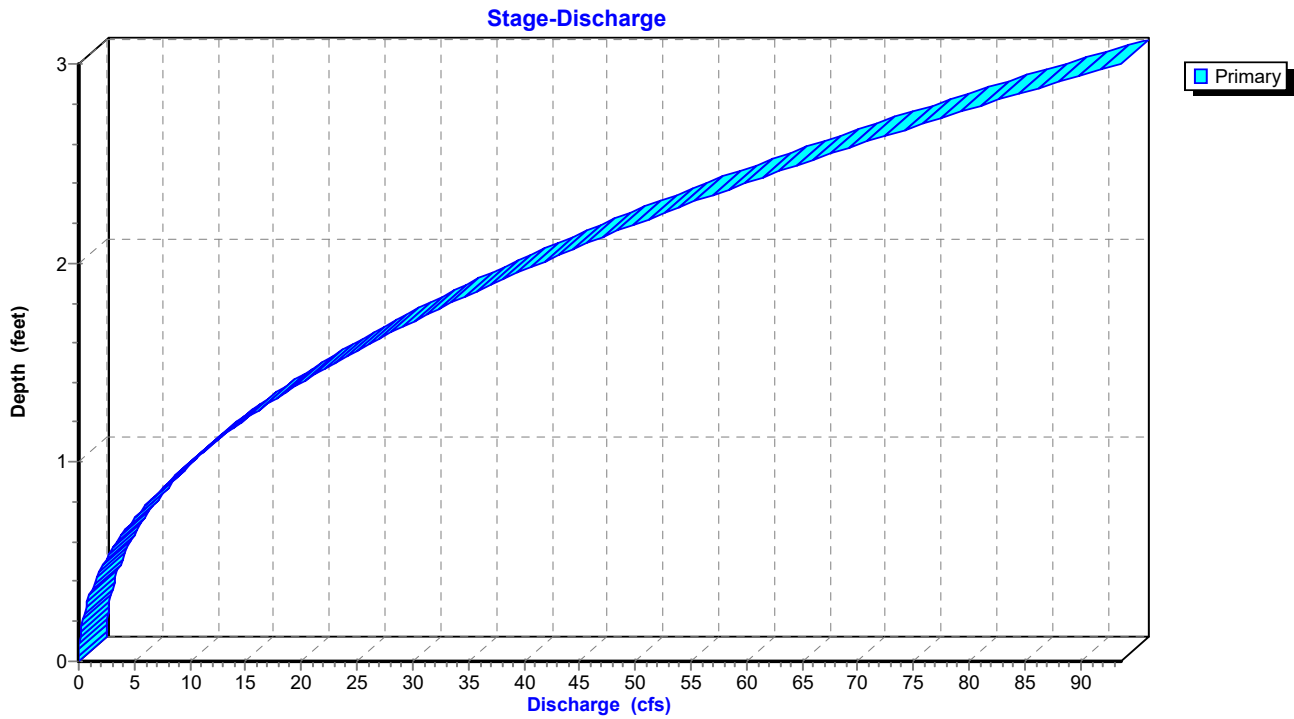

Reach R1: Drainage Easement

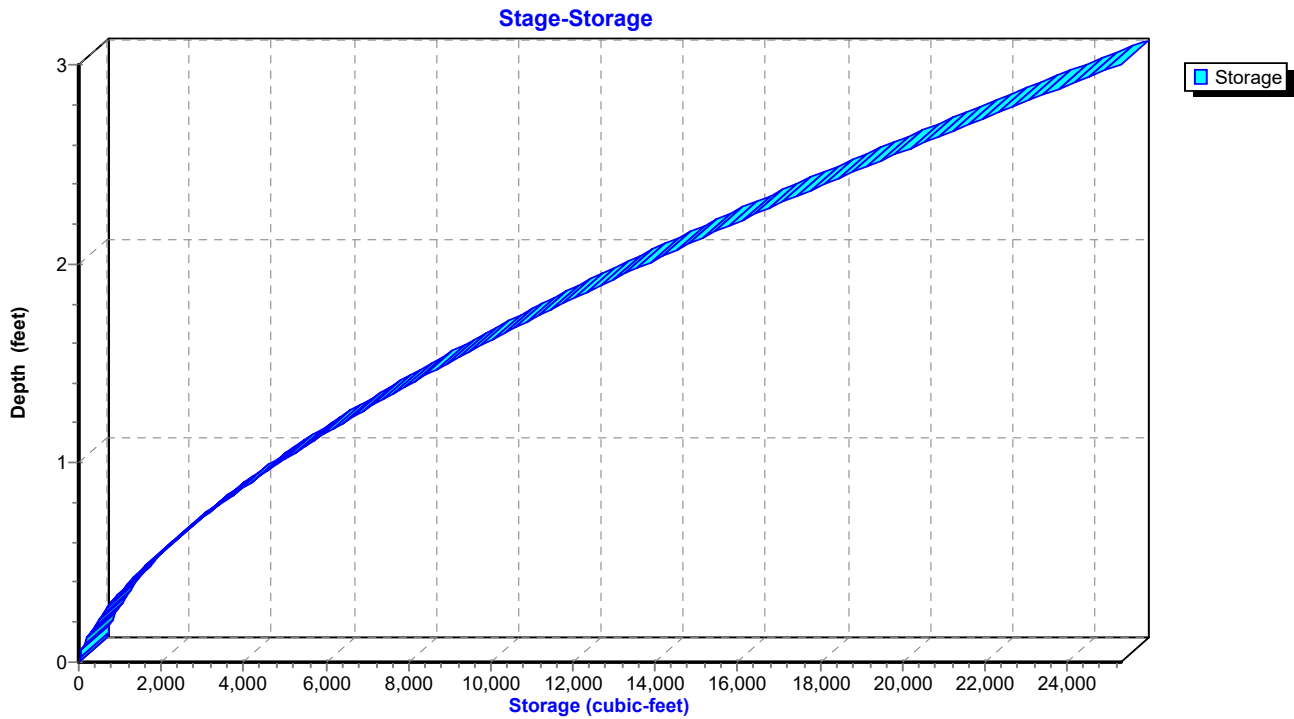

IGN Padua Ridge Existing v4 w culvert

Type II 24-hr 10-yr Rainfall=3.61"

Prepared by JMT

Printed 1/31/2022

HydroCAD® 10.00-20 s/n 02102 © 2017 HydroCAD Software Solutions LLC

Page 19

Hydrograph for Reach R1: Drainage Easement

Time (hours)	Inflow (cfs)	Storage (cubic-feet)	Elevation (feet)	Outflow (cfs)
0.05	0.00	0	780.00	0.00
2.55	0.00	0	780.00	0.00
5.05	0.00	0	780.00	0.00
7.55	0.00	0	780.00	0.00
10.05	0.00	2	780.00	0.00
12.55	8.77	5,383	781.07	15.16
15.05	2.99	2,050	780.56	3.01
17.55	2.33	1,730	780.50	2.39
20.05	1.73	1,411	780.44	1.80
22.55	1.51	1,266	780.41	1.53
25.05	0.68	732	780.28	0.72
27.55	0.65	699	780.27	0.66
30.05	0.63	679	780.27	0.63
32.55	0.60	658	780.26	0.60
35.05	0.57	636	780.26	0.58
37.55	0.54	613	780.25	0.55
40.05	0.51	588	780.24	0.52
42.55	0.48	562	780.24	0.48
45.05	0.44	534	780.23	0.45
47.55	0.41	504	780.22	0.41
50.05	0.37	472	780.21	0.38
52.55	0.33	437	780.20	0.34
55.05	0.29	399	780.19	0.30
57.55	0.25	359	780.18	0.26
60.05	0.21	314	780.16	0.21
62.55	0.16	265	780.14	0.17
65.05	0.11	211	780.12	0.12
67.55	0.07	148	780.10	0.07
70.05	0.04	104	780.08	0.04
72.55	0.02	75	780.06	0.03
75.05	0.02	53	780.05	0.02
77.55	0.01	41	780.04	0.01
80.05	0.01	37	780.04	0.01
82.55	0.01	34	780.04	0.01
85.05	0.01	31	780.03	0.01
87.55	0.01	28	780.03	0.01
90.05	0.01	26	780.03	0.01
92.55	0.00	24	780.03	0.01
95.05	0.00	21	780.02	0.00
97.55	0.00	18	780.02	0.00
100.05	0.00	15	780.02	0.00
102.55	0.00	13	780.02	0.00
105.05	0.00	11	780.01	0.00
107.55	0.00	10	780.01	0.00
110.05	0.00	9	780.01	0.00
112.55	0.00	7	780.01	0.00
115.05	0.00	6	780.01	0.00
117.55	0.00	6	780.01	0.00

IGN Padua Ridge Existing v4 w culvert

Type II 24-hr 10-yr Rainfall=3.61"

Prepared by JMT

Printed 1/31/2022

HydroCAD® 10.00-20 s/n 02102 © 2017 HydroCAD Software Solutions LLC

Page 20

Stage-Discharge for Reach R1: Drainage Easement

Elevation (feet)	Velocity (ft/sec)	Discharge (cfs)	Elevation (feet)	Velocity (ft/sec)	Discharge (cfs)	Elevation (feet)	Velocity (ft/sec)	Discharge (cfs)
780.00	0.00	0.00	781.04	4.43	10.86	782.08	6.48	44.86
780.02	0.31	0.00	781.06	4.48	11.29	782.10	6.51	45.74
780.04	0.56	0.01	781.08	4.53	11.74	782.12	6.54	46.62
780.06	0.74	0.03	781.10	4.58	12.19	782.14	6.57	47.52
780.08	0.89	0.05	781.12	4.62	12.66	782.16	6.60	48.42
780.10	1.03	0.08	781.14	4.67	13.12	782.18	6.64	49.33
780.12	1.16	0.11	781.16	4.72	13.61	782.20	6.67	50.25
780.14	1.29	0.16	781.18	4.76	14.09	782.22	6.70	51.17
780.16	1.40	0.21	781.20	4.81	14.59	782.24	6.73	52.11
780.18	1.51	0.27	781.22	4.85	15.10	782.26	6.76	53.05
780.20	1.62	0.34	781.24	4.89	15.61	782.28	6.79	54.00
780.22	1.72	0.41	781.26	4.94	16.13	782.30	6.82	54.96
780.24	1.82	0.49	781.28	4.98	16.66	782.32	6.85	55.93
780.26	1.91	0.59	781.30	5.03	17.20	782.34	6.88	56.90
780.28	2.01	0.69	781.32	5.07	17.75	782.36	6.91	57.88
780.30	2.10	0.79	781.34	5.11	18.31	782.38	6.94	58.88
780.32	2.18	0.91	781.36	5.15	18.88	782.40	6.97	59.87
780.34	2.27	1.04	781.38	5.19	19.45	782.42	7.00	60.88
780.36	2.35	1.17	781.40	5.24	20.03	782.44	7.03	61.90
780.38	2.43	1.32	781.42	5.28	20.62	782.46	7.06	62.92
780.40	2.51	1.47	781.44	5.32	21.22	782.48	7.09	63.96
780.42	2.58	1.62	781.46	5.36	21.83	782.50	7.12	65.00
780.44	2.66	1.79	781.48	5.40	22.45	782.52	7.15	66.04
780.46	2.73	1.97	781.50	5.44	23.07	782.54	7.18	67.10
780.48	2.80	2.15	781.52	5.48	23.71	782.56	7.21	68.17
780.50	2.87	2.35	781.54	5.52	24.35	782.58	7.23	69.24
780.52	2.94	2.55	781.56	5.55	25.00	782.60	7.26	70.32
780.54	3.01	2.76	781.58	5.59	25.66	782.62	7.29	71.41
780.56	3.08	2.98	781.60	5.63	26.32	782.64	7.32	72.51
780.58	3.15	3.21	781.62	5.67	27.00	782.66	7.35	73.62
780.60	3.21	3.45	781.64	5.71	27.68	782.68	7.38	74.73
780.62	3.27	3.69	781.66	5.74	28.38	782.70	7.40	75.85
780.64	3.34	3.95	781.68	5.78	29.08	782.72	7.43	76.98
780.66	3.40	4.21	781.70	5.82	29.79	782.74	7.46	78.12
780.68	3.46	4.48	781.72	5.86	30.51	782.76	7.49	79.26
780.70	3.52	4.76	781.74	5.89	31.23	782.78	7.51	80.42
780.72	3.58	5.05	781.76	5.93	31.97	782.80	7.54	81.58
780.74	3.64	5.35	781.78	5.96	32.71	782.82	7.57	82.75
780.76	3.70	5.66	781.80	6.00	33.46	782.84	7.59	83.93
780.78	3.75	5.97	781.82	6.03	34.22	782.86	7.62	85.12
780.80	3.81	6.30	781.84	6.07	34.99	782.88	7.65	86.31
780.82	3.86	6.63	781.86	6.11	35.77	782.90	7.67	87.51
780.84	3.92	6.97	781.88	6.14	36.55	782.92	7.70	88.72
780.86	3.97	7.32	781.90	6.17	37.35	782.94	7.73	89.94
780.88	4.03	7.68	781.92	6.21	38.15	782.96	7.75	91.17
780.90	4.08	8.04	781.94	6.24	38.96	782.98	7.78	92.40
780.92	4.13	8.42	781.96	6.28	39.78	783.00	7.80	93.64
780.94	4.18	8.81	781.98	6.31	40.60			
780.96	4.23	9.20	782.00	6.34	41.44			
780.98	4.28	9.60	782.02	6.38	42.28			
781.00	4.33	10.01	782.04	6.41	43.13			
781.02	4.38	10.43	782.06	6.44	43.99			

Stage-Area-Storage for Reach R1: Drainage Easement

Elevation (feet)	End-Area (sq-ft)	Storage (cubic-feet)	Elevation (feet)	End-Area (sq-ft)	Storage (cubic-feet)
780.00	0.0	0	782.60	9.7	20,419
780.05	0.0	56	782.65	10.0	21,011
780.10	0.1	155	782.70	10.2	21,608
780.15	0.1	283	782.75	10.5	22,212
780.20	0.2	436	782.80	10.8	22,820
780.25	0.3	610	782.85	11.1	23,434
780.30	0.4	800	782.90	11.4	24,053
780.35	0.5	1,009	782.95	11.7	24,678
780.40	0.6	1,233	783.00	12.0	25,308
780.45	0.7	1,470			
780.50	0.8	1,723			
780.55	0.9	1,987			
780.60	1.1	2,264			
780.65	1.2	2,553			
780.70	1.4	2,853			
780.75	1.5	3,164			
780.80	1.7	3,485			
780.85	1.8	3,817			
780.90	2.0	4,159			
780.95	2.1	4,510			
781.00	2.3	4,871			
781.05	2.5	5,240			
781.10	2.7	5,619			
781.15	2.8	6,007			
781.20	3.0	6,402			
781.25	3.2	6,807			
781.30	3.4	7,220			
781.35	3.6	7,640			
781.40	3.8	8,068			
781.45	4.0	8,504			
781.50	4.2	8,948			
781.55	4.5	9,399			
781.60	4.7	9,858			
781.65	4.9	10,323			
781.70	5.1	10,796			
781.75	5.3	11,276			
781.80	5.6	11,762			
781.85	5.8	12,256			
781.90	6.0	12,756			
781.95	6.3	13,263			
782.00	6.5	13,776			
782.05	6.8	14,296			
782.10	7.0	14,822			
782.15	7.3	15,355			
782.20	7.5	15,893			
782.25	7.8	16,438			
782.30	8.1	16,989			
782.35	8.3	17,546			
782.40	8.6	18,109			
782.45	8.9	18,678			
782.50	9.1	19,253			
782.55	9.4	19,833			

Summary for Pond P1: Infiltration Area

Inflow Area = 6.720 ac, 0.00% Impervious, Inflow Depth = 0.35" for 10-yr event
 Inflow = 1.66 cfs @ 12.11 hrs, Volume= 0.195 af
 Outflow = 0.13 cfs @ 17.89 hrs, Volume= 0.195 af, Atten= 92%, Lag= 347.1 min
 Discarded = 0.13 cfs @ 17.89 hrs, Volume= 0.195 af

Routing by Stor-Ind method, Time Span= 0.05-120.00 hrs, dt= 0.05 hrs
 Peak Elev= 855.30' @ 17.89 hrs Surf.Area= 11,336 sf Storage= 3,345 cf

Plug-Flow detention time= 305.3 min calculated for 0.195 af (100% of inflow)
 Center-of-Mass det. time= 305.1 min (1,251.7 - 946.6)

Volume	Invert	Avail.Storage	Storage Description
#1	855.00'	22,672 cf	Custom Stage Data (Prismatic) Listed below (Recalc)

Elevation (feet)	Surf.Area (sq-ft)	Inc.Store (cubic-feet)	Cum.Store (cubic-feet)
855.00	11,336	0	0
856.00	11,336	11,336	11,336
857.00	11,336	11,336	22,672

Device	Routing	Invert	Outlet Devices
#1	Discarded	855.00'	0.500 in/hr Exfiltration over Surface area Conductivity to Groundwater Elevation = 840.00'

Discarded OutFlow Max=0.13 cfs @ 17.89 hrs HW=855.30' (Free Discharge)

↑**1=Exfiltration** (Controls 0.13 cfs)

Pond P1: Infiltration Area

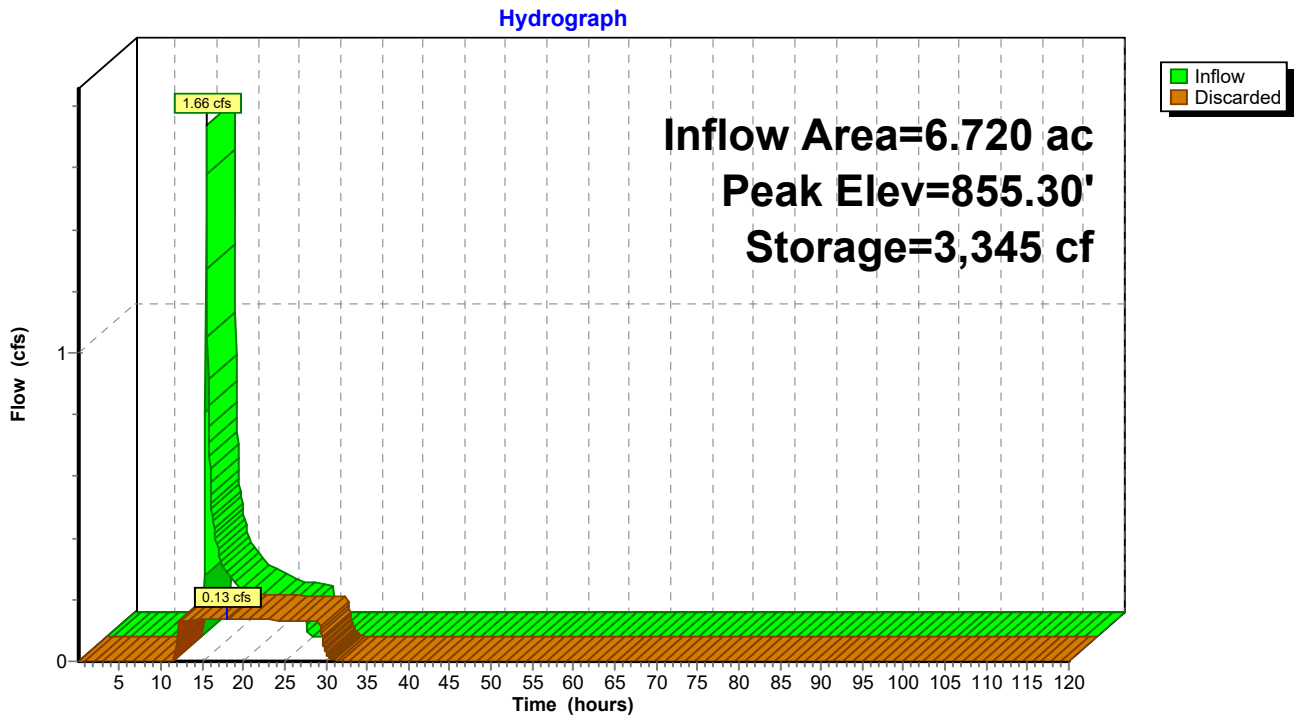

Pond P1: Infiltration Area

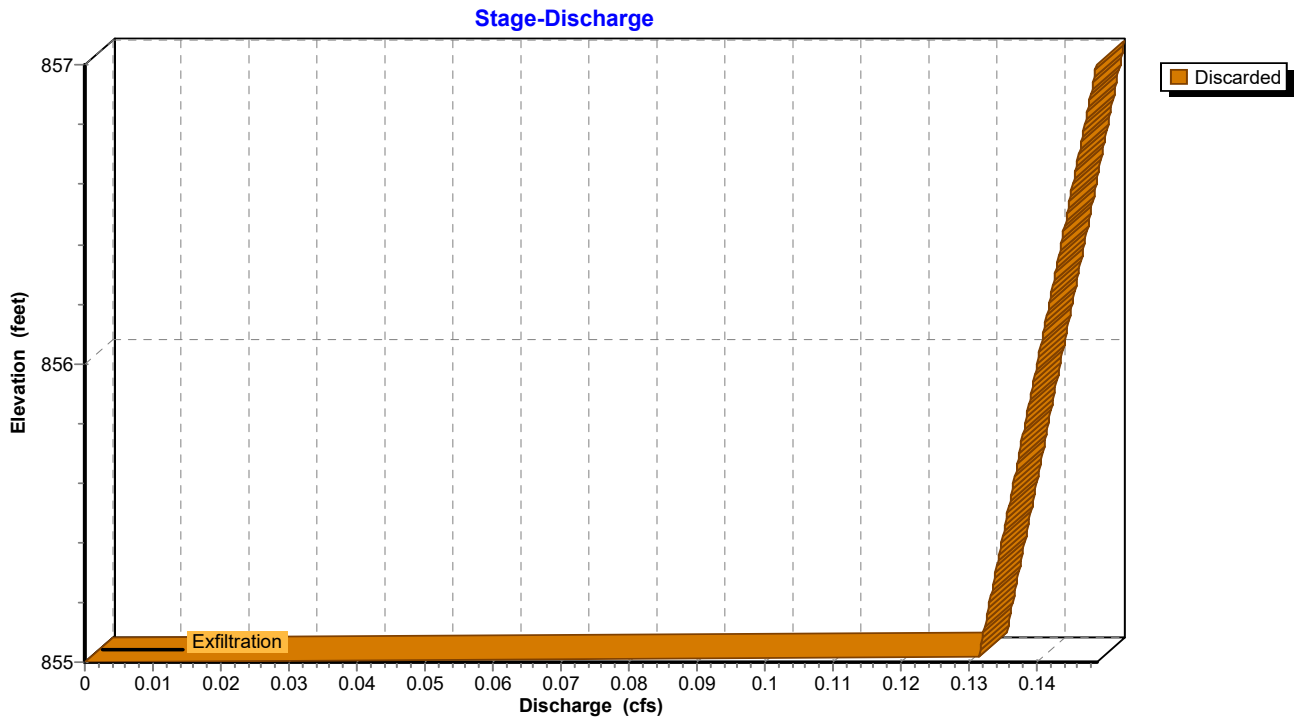

Pond P1: Infiltration Area

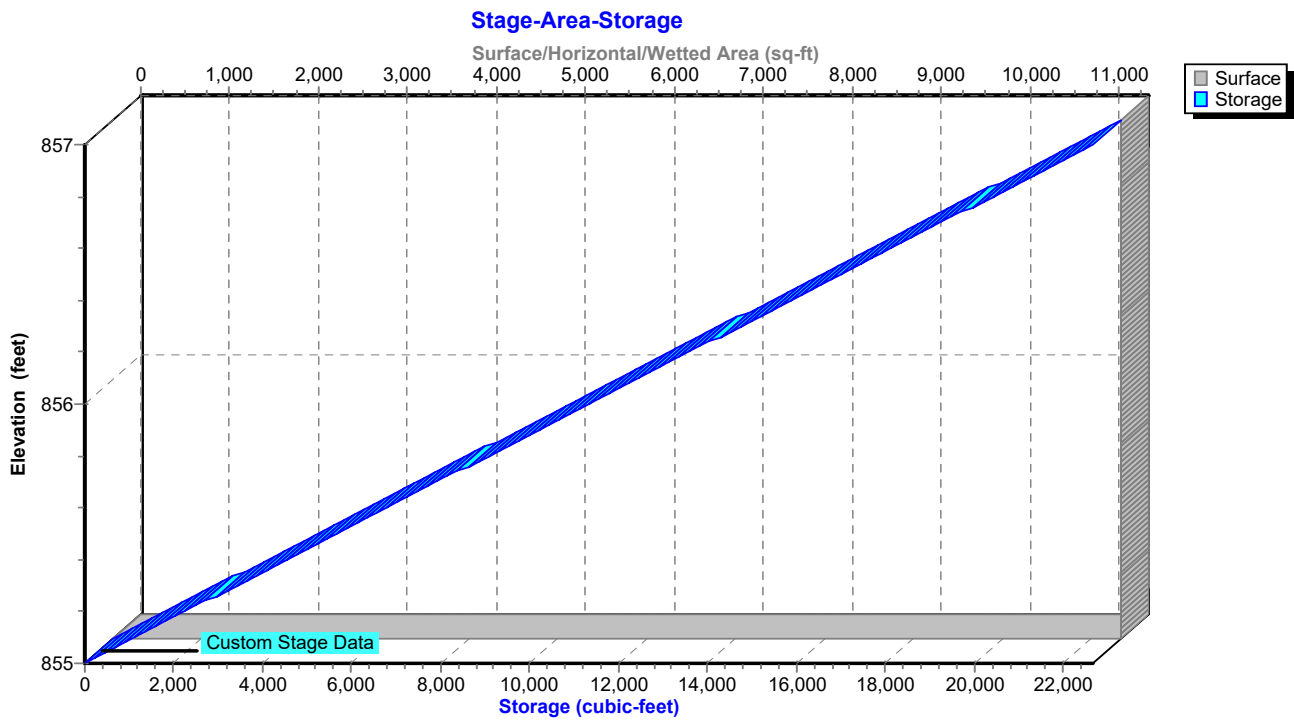

IGN Padua Ridge Existing v4 w culvert

Type II 24-hr 10-yr Rainfall=3.61"

Prepared by JMT

Printed 1/31/2022

HydroCAD® 10.00-20 s/n 02102 © 2017 HydroCAD Software Solutions LLC

Page 25

Hydrograph for Pond P1: Infiltration Area

Time (hours)	Inflow (cfs)	Storage (cubic-feet)	Elevation (feet)	Discarded (cfs)
0.05	0.00	0	855.00	0.00
2.55	0.00	0	855.00	0.00
5.05	0.00	0	855.00	0.00
7.55	0.00	0	855.00	0.00
10.05	0.00	0	855.00	0.00
12.55	0.54	1,786	855.16	0.13
15.05	0.19	3,109	855.27	0.13
17.55	0.14	3,343	855.29	0.13
20.05	0.10	3,223	855.28	0.13
22.55	0.09	2,888	855.25	0.13
25.05	0.00	2,233	855.20	0.13
27.55	0.00	1,041	855.09	0.13
30.05	0.00	44	855.00	0.03
32.55	0.00	0	855.00	0.00
35.05	0.00	0	855.00	0.00
37.55	0.00	0	855.00	0.00
40.05	0.00	0	855.00	0.00
42.55	0.00	0	855.00	0.00
45.05	0.00	0	855.00	0.00
47.55	0.00	0	855.00	0.00
50.05	0.00	0	855.00	0.00
52.55	0.00	0	855.00	0.00
55.05	0.00	0	855.00	0.00
57.55	0.00	0	855.00	0.00
60.05	0.00	0	855.00	0.00
62.55	0.00	0	855.00	0.00
65.05	0.00	0	855.00	0.00
67.55	0.00	0	855.00	0.00
70.05	0.00	0	855.00	0.00
72.55	0.00	0	855.00	0.00
75.05	0.00	0	855.00	0.00
77.55	0.00	0	855.00	0.00
80.05	0.00	0	855.00	0.00
82.55	0.00	0	855.00	0.00
85.05	0.00	0	855.00	0.00
87.55	0.00	0	855.00	0.00
90.05	0.00	0	855.00	0.00
92.55	0.00	0	855.00	0.00
95.05	0.00	0	855.00	0.00
97.55	0.00	0	855.00	0.00
100.05	0.00	0	855.00	0.00
102.55	0.00	0	855.00	0.00
105.05	0.00	0	855.00	0.00
107.55	0.00	0	855.00	0.00
110.05	0.00	0	855.00	0.00
112.55	0.00	0	855.00	0.00
115.05	0.00	0	855.00	0.00
117.55	0.00	0	855.00	0.00

Stage-Discharge for Pond P1: Infiltration Area

Elevation (feet)	Discarded (cfs)	Elevation (feet)	Discarded (cfs)	Elevation (feet)	Discarded (cfs)	Elevation (feet)	Discarded (cfs)
855.00	0.00	855.52	0.14	856.04	0.14	856.56	0.14
855.01	0.13	855.53	0.14	856.05	0.14	856.57	0.14
855.02	0.13	855.54	0.14	856.06	0.14	856.58	0.15
855.03	0.13	855.55	0.14	856.07	0.14	856.59	0.15
855.04	0.13	855.56	0.14	856.08	0.14	856.60	0.15
855.05	0.13	855.57	0.14	856.09	0.14	856.61	0.15
855.06	0.13	855.58	0.14	856.10	0.14	856.62	0.15
855.07	0.13	855.59	0.14	856.11	0.14	856.63	0.15
855.08	0.13	855.60	0.14	856.12	0.14	856.64	0.15
855.09	0.13	855.61	0.14	856.13	0.14	856.65	0.15
855.10	0.13	855.62	0.14	856.14	0.14	856.66	0.15
855.11	0.13	855.63	0.14	856.15	0.14	856.67	0.15
855.12	0.13	855.64	0.14	856.16	0.14	856.68	0.15
855.13	0.13	855.65	0.14	856.17	0.14	856.69	0.15
855.14	0.13	855.66	0.14	856.18	0.14	856.70	0.15
855.15	0.13	855.67	0.14	856.19	0.14	856.71	0.15
855.16	0.13	855.68	0.14	856.20	0.14	856.72	0.15
855.17	0.13	855.69	0.14	856.21	0.14	856.73	0.15
855.18	0.13	855.70	0.14	856.22	0.14	856.74	0.15
855.19	0.13	855.71	0.14	856.23	0.14	856.75	0.15
855.20	0.13	855.72	0.14	856.24	0.14	856.76	0.15
855.21	0.13	855.73	0.14	856.25	0.14	856.77	0.15
855.22	0.13	855.74	0.14	856.26	0.14	856.78	0.15
855.23	0.13	855.75	0.14	856.27	0.14	856.79	0.15
855.24	0.13	855.76	0.14	856.28	0.14	856.80	0.15
855.25	0.13	855.77	0.14	856.29	0.14	856.81	0.15
855.26	0.13	855.78	0.14	856.30	0.14	856.82	0.15
855.27	0.13	855.79	0.14	856.31	0.14	856.83	0.15
855.28	0.13	855.80	0.14	856.32	0.14	856.84	0.15
855.29	0.13	855.81	0.14	856.33	0.14	856.85	0.15
855.30	0.13	855.82	0.14	856.34	0.14	856.86	0.15
855.31	0.13	855.83	0.14	856.35	0.14	856.87	0.15
855.32	0.13	855.84	0.14	856.36	0.14	856.88	0.15
855.33	0.13	855.85	0.14	856.37	0.14	856.89	0.15
855.34	0.13	855.86	0.14	856.38	0.14	856.90	0.15
855.35	0.13	855.87	0.14	856.39	0.14	856.91	0.15
855.36	0.13	855.88	0.14	856.40	0.14	856.92	0.15
855.37	0.13	855.89	0.14	856.41	0.14	856.93	0.15
855.38	0.13	855.90	0.14	856.42	0.14	856.94	0.15
855.39	0.13	855.91	0.14	856.43	0.14	856.95	0.15
855.40	0.13	855.92	0.14	856.44	0.14	856.96	0.15
855.41	0.13	855.93	0.14	856.45	0.14	856.97	0.15
855.42	0.13	855.94	0.14	856.46	0.14	856.98	0.15
855.43	0.13	855.95	0.14	856.47	0.14	856.99	0.15
855.44	0.14	855.96	0.14	856.48	0.14	857.00	0.15
855.45	0.14	855.97	0.14	856.49	0.14		
855.46	0.14	855.98	0.14	856.50	0.14		
855.47	0.14	855.99	0.14	856.51	0.14		
855.48	0.14	856.00	0.14	856.52	0.14		
855.49	0.14	856.01	0.14	856.53	0.14		
855.50	0.14	856.02	0.14	856.54	0.14		
855.51	0.14	856.03	0.14	856.55	0.14		

Stage-Area-Storage for Pond P1: Infiltration Area

Elevation (feet)	Surface (sq-ft)	Storage (cubic-feet)	Elevation (feet)	Surface (sq-ft)	Storage (cubic-feet)
855.00	11,336	0	856.04	11,336	11,789
855.02	11,336	227	856.06	11,336	12,016
855.04	11,336	453	856.08	11,336	12,243
855.06	11,336	680	856.10	11,336	12,470
855.08	11,336	907	856.12	11,336	12,696
855.10	11,336	1,134	856.14	11,336	12,923
855.12	11,336	1,360	856.16	11,336	13,150
855.14	11,336	1,587	856.18	11,336	13,376
855.16	11,336	1,814	856.20	11,336	13,603
855.18	11,336	2,040	856.22	11,336	13,830
855.20	11,336	2,267	856.24	11,336	14,057
855.22	11,336	2,494	856.26	11,336	14,283
855.24	11,336	2,721	856.28	11,336	14,510
855.26	11,336	2,947	856.30	11,336	14,737
855.28	11,336	3,174	856.32	11,336	14,964
855.30	11,336	3,401	856.34	11,336	15,190
855.32	11,336	3,628	856.36	11,336	15,417
855.34	11,336	3,854	856.38	11,336	15,644
855.36	11,336	4,081	856.40	11,336	15,870
855.38	11,336	4,308	856.42	11,336	16,097
855.40	11,336	4,534	856.44	11,336	16,324
855.42	11,336	4,761	856.46	11,336	16,551
855.44	11,336	4,988	856.48	11,336	16,777
855.46	11,336	5,215	856.50	11,336	17,004
855.48	11,336	5,441	856.52	11,336	17,231
855.50	11,336	5,668	856.54	11,336	17,457
855.52	11,336	5,895	856.56	11,336	17,684
855.54	11,336	6,121	856.58	11,336	17,911
855.56	11,336	6,348	856.60	11,336	18,138
855.58	11,336	6,575	856.62	11,336	18,364
855.60	11,336	6,802	856.64	11,336	18,591
855.62	11,336	7,028	856.66	11,336	18,818
855.64	11,336	7,255	856.68	11,336	19,044
855.66	11,336	7,482	856.70	11,336	19,271
855.68	11,336	7,708	856.72	11,336	19,498
855.70	11,336	7,935	856.74	11,336	19,725
855.72	11,336	8,162	856.76	11,336	19,951
855.74	11,336	8,389	856.78	11,336	20,178
855.76	11,336	8,615	856.80	11,336	20,405
855.78	11,336	8,842	856.82	11,336	20,632
855.80	11,336	9,069	856.84	11,336	20,858
855.82	11,336	9,296	856.86	11,336	21,085
855.84	11,336	9,522	856.88	11,336	21,312
855.86	11,336	9,749	856.90	11,336	21,538
855.88	11,336	9,976	856.92	11,336	21,765
855.90	11,336	10,202	856.94	11,336	21,992
855.92	11,336	10,429	856.96	11,336	22,219
855.94	11,336	10,656	856.98	11,336	22,445
855.96	11,336	10,883	857.00	11,336	22,672
855.98	11,336	11,109			
856.00	11,336	11,336			
856.02	11,336	11,563			

IGN Padua Ridge Existing v4 w culvert

Type II 24-hr 10-yr Rainfall=3.61"

Prepared by JMT

Printed 1/31/2022

HydroCAD® 10.00-20 s/n 02102 © 2017 HydroCAD Software Solutions LLC

Page 28

Summary for Pond P3: Infiltration Area

Inflow Area = 13.661 ac, 0.00% Impervious, Inflow Depth = 0.00" for 10-yr event
 Inflow = 0.00 cfs @ 0.05 hrs, Volume= 0.000 af
 Outflow = 0.00 cfs @ 0.05 hrs, Volume= 0.000 af, Atten= 0%, Lag= 0.0 min
 Discarded = 0.00 cfs @ 0.05 hrs, Volume= 0.000 af

Routing by Stor-Ind method, Time Span= 0.05-120.00 hrs, dt= 0.05 hrs
 Peak Elev= 862.00' @ 0.05 hrs Surf.Area= 10,679 sf Storage= 0 cf

Plug-Flow detention time= (not calculated: initial storage exceeds outflow)
 Center-of-Mass det. time= (not calculated: no inflow)

Volume	Invert	Avail.Storage	Storage Description
#1	862.00'	21,358 cf	Custom Stage Data (Prismatic) Listed below (Recalc)

Elevation (feet)	Surf.Area (sq-ft)	Inc.Store (cubic-feet)	Cum.Store (cubic-feet)
862.00	10,679	0	0
863.00	10,679	10,679	10,679
864.00	10,679	10,679	21,358

Device	Routing	Invert	Outlet Devices
#1	Discarded	862.00'	0.500 in/hr Exfiltration over Surface area Conductivity to Groundwater Elevation = 840.00'

Discarded OutFlow Max=0.00 cfs @ 0.05 hrs HW=862.00' (Free Discharge)

↑**1=Exfiltration** (Passes 0.00 cfs of 0.12 cfs potential flow)

Pond P3: Infiltration Area

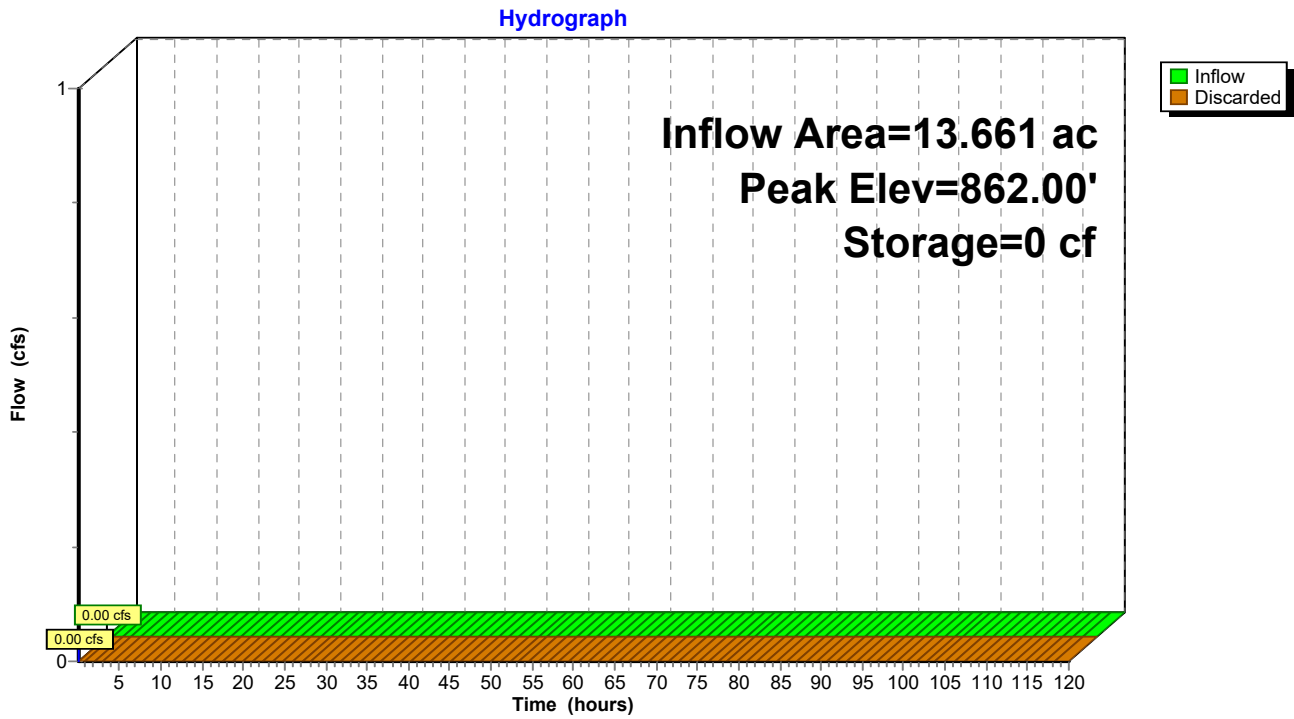

Pond P3: Infiltration Area

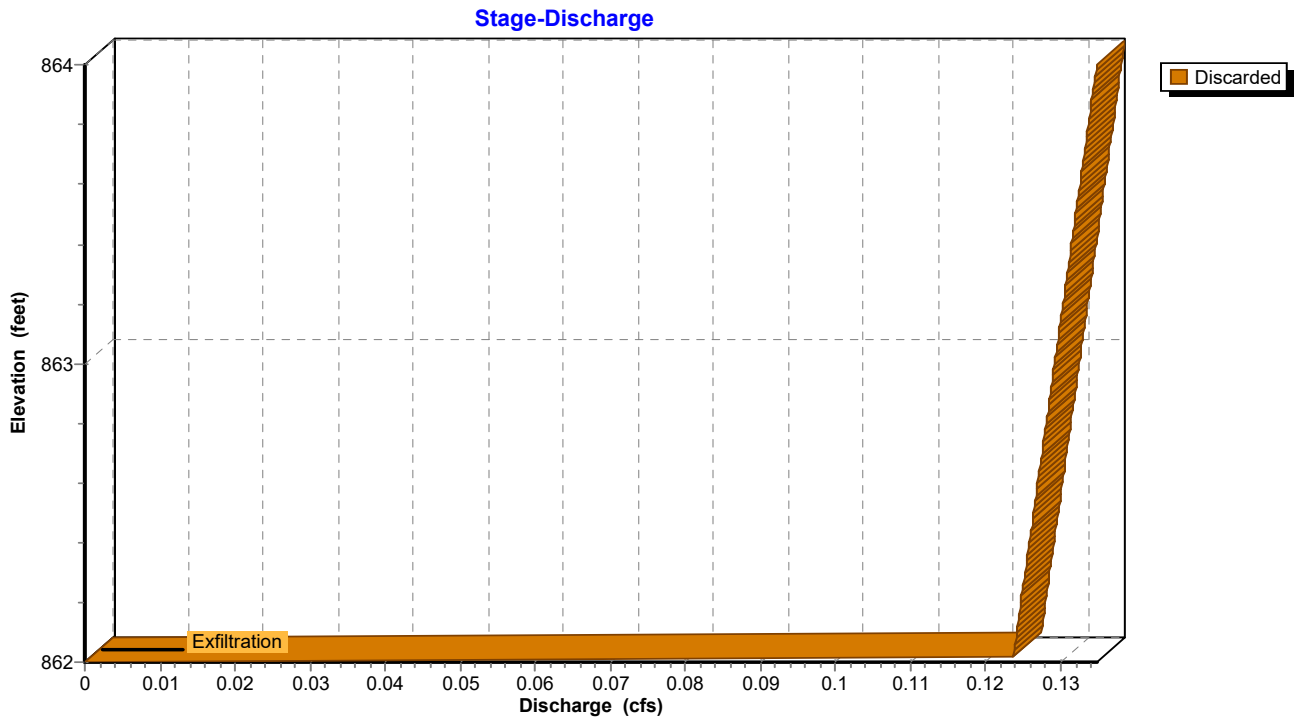

Pond P3: Infiltration Area

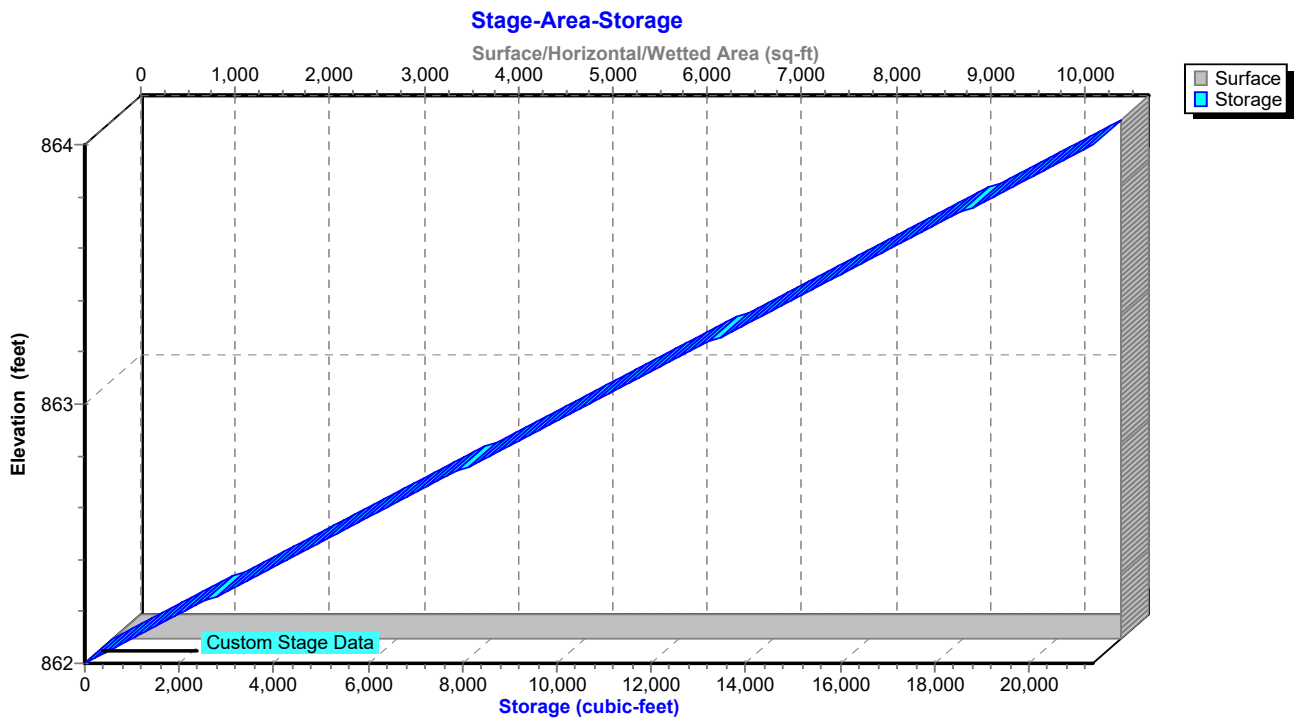

Hydrograph for Pond P3: Infiltration Area

Time (hours)	Inflow (cfs)	Elevation (feet)	Discarded (cfs)
0.05	0.00	862.00	0.00
2.55	0.00	862.00	0.00
5.05	0.00	862.00	0.00
7.55	0.00	862.00	0.00
10.05	0.00	862.00	0.00
12.55	0.00	862.00	0.00
15.05	0.00	862.00	0.00
17.55	0.00	862.00	0.00
20.05	0.00	862.00	0.00
22.55	0.00	862.00	0.00
25.05	0.00	862.00	0.00
27.55	0.00	862.00	0.00
30.05	0.00	862.00	0.00
32.55	0.00	862.00	0.00
35.05	0.00	862.00	0.00
37.55	0.00	862.00	0.00
40.05	0.00	862.00	0.00
42.55	0.00	862.00	0.00
45.05	0.00	862.00	0.00
47.55	0.00	862.00	0.00
50.05	0.00	862.00	0.00
52.55	0.00	862.00	0.00
55.05	0.00	862.00	0.00
57.55	0.00	862.00	0.00
60.05	0.00	862.00	0.00
62.55	0.00	862.00	0.00
65.05	0.00	862.00	0.00
67.55	0.00	862.00	0.00
70.05	0.00	862.00	0.00
72.55	0.00	862.00	0.00
75.05	0.00	862.00	0.00
77.55	0.00	862.00	0.00
80.05	0.00	862.00	0.00
82.55	0.00	862.00	0.00
85.05	0.00	862.00	0.00
87.55	0.00	862.00	0.00
90.05	0.00	862.00	0.00
92.55	0.00	862.00	0.00
95.05	0.00	862.00	0.00
97.55	0.00	862.00	0.00
100.05	0.00	862.00	0.00
102.55	0.00	862.00	0.00
105.05	0.00	862.00	0.00
107.55	0.00	862.00	0.00
110.05	0.00	862.00	0.00
112.55	0.00	862.00	0.00
115.05	0.00	862.00	0.00
117.55	0.00	862.00	0.00

Stage-Discharge for Pond P3: Infiltration Area

Elevation (feet)	Discarded (cfs)	Elevation (feet)	Discarded (cfs)	Elevation (feet)	Discarded (cfs)	Elevation (feet)	Discarded (cfs)
862.00	0.00	862.52	0.13	863.04	0.13	863.56	0.13
862.01	0.12	862.53	0.13	863.05	0.13	863.57	0.13
862.02	0.12	862.54	0.13	863.06	0.13	863.58	0.13
862.03	0.12	862.55	0.13	863.07	0.13	863.59	0.13
862.04	0.12	862.56	0.13	863.08	0.13	863.60	0.13
862.05	0.12	862.57	0.13	863.09	0.13	863.61	0.13
862.06	0.12	862.58	0.13	863.10	0.13	863.62	0.13
862.07	0.12	862.59	0.13	863.11	0.13	863.63	0.13
862.08	0.12	862.60	0.13	863.12	0.13	863.64	0.13
862.09	0.12	862.61	0.13	863.13	0.13	863.65	0.13
862.10	0.12	862.62	0.13	863.14	0.13	863.66	0.13
862.11	0.12	862.63	0.13	863.15	0.13	863.67	0.13
862.12	0.12	862.64	0.13	863.16	0.13	863.68	0.13
862.13	0.12	862.65	0.13	863.17	0.13	863.69	0.13
862.14	0.12	862.66	0.13	863.18	0.13	863.70	0.13
862.15	0.12	862.67	0.13	863.19	0.13	863.71	0.13
862.16	0.12	862.68	0.13	863.20	0.13	863.72	0.13
862.17	0.12	862.69	0.13	863.21	0.13	863.73	0.13
862.18	0.12	862.70	0.13	863.22	0.13	863.74	0.13
862.19	0.12	862.71	0.13	863.23	0.13	863.75	0.13
862.20	0.12	862.72	0.13	863.24	0.13	863.76	0.13
862.21	0.12	862.73	0.13	863.25	0.13	863.77	0.13
862.22	0.12	862.74	0.13	863.26	0.13	863.78	0.13
862.23	0.12	862.75	0.13	863.27	0.13	863.79	0.13
862.24	0.12	862.76	0.13	863.28	0.13	863.80	0.13
862.25	0.13	862.77	0.13	863.29	0.13	863.81	0.13
862.26	0.13	862.78	0.13	863.30	0.13	863.82	0.13
862.27	0.13	862.79	0.13	863.31	0.13	863.83	0.13
862.28	0.13	862.80	0.13	863.32	0.13	863.84	0.13
862.29	0.13	862.81	0.13	863.33	0.13	863.85	0.13
862.30	0.13	862.82	0.13	863.34	0.13	863.86	0.13
862.31	0.13	862.83	0.13	863.35	0.13	863.87	0.13
862.32	0.13	862.84	0.13	863.36	0.13	863.88	0.13
862.33	0.13	862.85	0.13	863.37	0.13	863.89	0.13
862.34	0.13	862.86	0.13	863.38	0.13	863.90	0.13
862.35	0.13	862.87	0.13	863.39	0.13	863.91	0.13
862.36	0.13	862.88	0.13	863.40	0.13	863.92	0.13
862.37	0.13	862.89	0.13	863.41	0.13	863.93	0.13
862.38	0.13	862.90	0.13	863.42	0.13	863.94	0.13
862.39	0.13	862.91	0.13	863.43	0.13	863.95	0.13
862.40	0.13	862.92	0.13	863.44	0.13	863.96	0.13
862.41	0.13	862.93	0.13	863.45	0.13	863.97	0.13
862.42	0.13	862.94	0.13	863.46	0.13	863.98	0.13
862.43	0.13	862.95	0.13	863.47	0.13	863.99	0.13
862.44	0.13	862.96	0.13	863.48	0.13	864.00	0.13
862.45	0.13	862.97	0.13	863.49	0.13		
862.46	0.13	862.98	0.13	863.50	0.13		
862.47	0.13	862.99	0.13	863.51	0.13		
862.48	0.13	863.00	0.13	863.52	0.13		
862.49	0.13	863.01	0.13	863.53	0.13		
862.50	0.13	863.02	0.13	863.54	0.13		
862.51	0.13	863.03	0.13	863.55	0.13		

Stage-Area-Storage for Pond P3: Infiltration Area

Elevation (feet)	Surface (sq-ft)	Storage (cubic-feet)	Elevation (feet)	Surface (sq-ft)	Storage (cubic-feet)
862.00	10,679	0	863.04	10,679	11,106
862.02	10,679	214	863.06	10,679	11,320
862.04	10,679	427	863.08	10,679	11,533
862.06	10,679	641	863.10	10,679	11,747
862.08	10,679	854	863.12	10,679	11,960
862.10	10,679	1,068	863.14	10,679	12,174
862.12	10,679	1,281	863.16	10,679	12,388
862.14	10,679	1,495	863.18	10,679	12,601
862.16	10,679	1,709	863.20	10,679	12,815
862.18	10,679	1,922	863.22	10,679	13,028
862.20	10,679	2,136	863.24	10,679	13,242
862.22	10,679	2,349	863.26	10,679	13,456
862.24	10,679	2,563	863.28	10,679	13,669
862.26	10,679	2,777	863.30	10,679	13,883
862.28	10,679	2,990	863.32	10,679	14,096
862.30	10,679	3,204	863.34	10,679	14,310
862.32	10,679	3,417	863.36	10,679	14,523
862.34	10,679	3,631	863.38	10,679	14,737
862.36	10,679	3,844	863.40	10,679	14,951
862.38	10,679	4,058	863.42	10,679	15,164
862.40	10,679	4,272	863.44	10,679	15,378
862.42	10,679	4,485	863.46	10,679	15,591
862.44	10,679	4,699	863.48	10,679	15,805
862.46	10,679	4,912	863.50	10,679	16,019
862.48	10,679	5,126	863.52	10,679	16,232
862.50	10,679	5,340	863.54	10,679	16,446
862.52	10,679	5,553	863.56	10,679	16,659
862.54	10,679	5,767	863.58	10,679	16,873
862.56	10,679	5,980	863.60	10,679	17,086
862.58	10,679	6,194	863.62	10,679	17,300
862.60	10,679	6,407	863.64	10,679	17,514
862.62	10,679	6,621	863.66	10,679	17,727
862.64	10,679	6,835	863.68	10,679	17,941
862.66	10,679	7,048	863.70	10,679	18,154
862.68	10,679	7,262	863.72	10,679	18,368
862.70	10,679	7,475	863.74	10,679	18,581
862.72	10,679	7,689	863.76	10,679	18,795
862.74	10,679	7,902	863.78	10,679	19,009
862.76	10,679	8,116	863.80	10,679	19,222
862.78	10,679	8,330	863.82	10,679	19,436
862.80	10,679	8,543	863.84	10,679	19,649
862.82	10,679	8,757	863.86	10,679	19,863
862.84	10,679	8,970	863.88	10,679	20,077
862.86	10,679	9,184	863.90	10,679	20,290
862.88	10,679	9,398	863.92	10,679	20,504
862.90	10,679	9,611	863.94	10,679	20,717
862.92	10,679	9,825	863.96	10,679	20,931
862.94	10,679	10,038	863.98	10,679	21,144
862.96	10,679	10,252	864.00	10,679	21,358
862.98	10,679	10,465			
863.00	10,679	10,679			
863.02	10,679	10,893			

IGN Padua Ridge Existing v4 w culvert

Type II 24-hr 10-yr Rainfall=3.61"

Prepared by JMT

Printed 1/31/2022

HydroCAD® 10.00-20 s/n 02102 © 2017 HydroCAD Software Solutions LLC

Page 34

Summary for Pond P4A: Mine Ponds

Inflow Area = 18.419 ac, 3.15% Impervious, Inflow Depth = 1.58" for 10-yr event
 Inflow = 56.88 cfs @ 11.93 hrs, Volume= 2.427 af
 Outflow = 56.75 cfs @ 11.94 hrs, Volume= 2.427 af, Atten= 0%, Lag= 0.1 min
 Primary = 56.75 cfs @ 11.94 hrs, Volume= 2.427 af

Routing by Stor-Ind method, Time Span= 0.05-120.00 hrs, dt= 0.05 hrs
 Starting Elev= 844.00' Surf.Area= 2,500 sf Storage= 2,114 cf
 Peak Elev= 844.26' @ 11.94 hrs Surf.Area= 2,500 sf Storage= 2,768 cf (654 cf above start)

Plug-Flow detention time= 16.3 min calculated for 2.378 af (98% of inflow)
 Center-of-Mass det. time= 0.4 min (836.8 - 836.3)

Volume	Invert	Avail.Storage	Storage Description
#1	843.00'	7,114 cf	Custom Stage Data (Conic) Listed below (Recalc)

Elevation (feet)	Surf.Area (sq-ft)	Inc.Store (cubic-feet)	Cum.Store (cubic-feet)	Wet.Area (sq-ft)
843.00	1,750	0	0	1,750
844.00	2,500	2,114	2,114	2,517
846.00	2,500	5,000	7,114	2,872

Device	Routing	Invert	Outlet Devices
#1	Primary	844.00'	130.0' long Sharp-Crested Rectangular Weir 0 End Contraction(s)

Primary OutFlow Max=53.96 cfs @ 11.94 hrs HW=844.25' (Free Discharge)

↑1=Sharp-Crested Rectangular Weir (Weir Controls 53.96 cfs @ 1.64 fps)

Pond P4A: Mine Ponds

Hydrograph

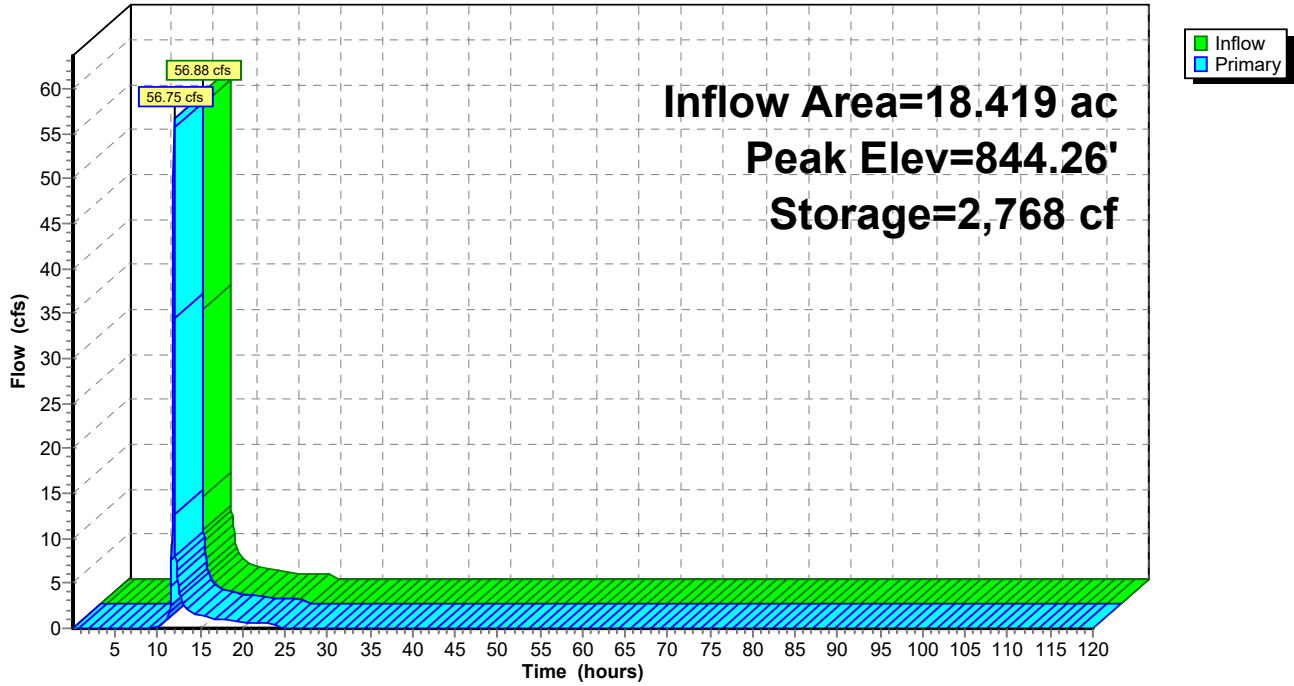

Pond P4A: Mine Ponds

Stage-Discharge

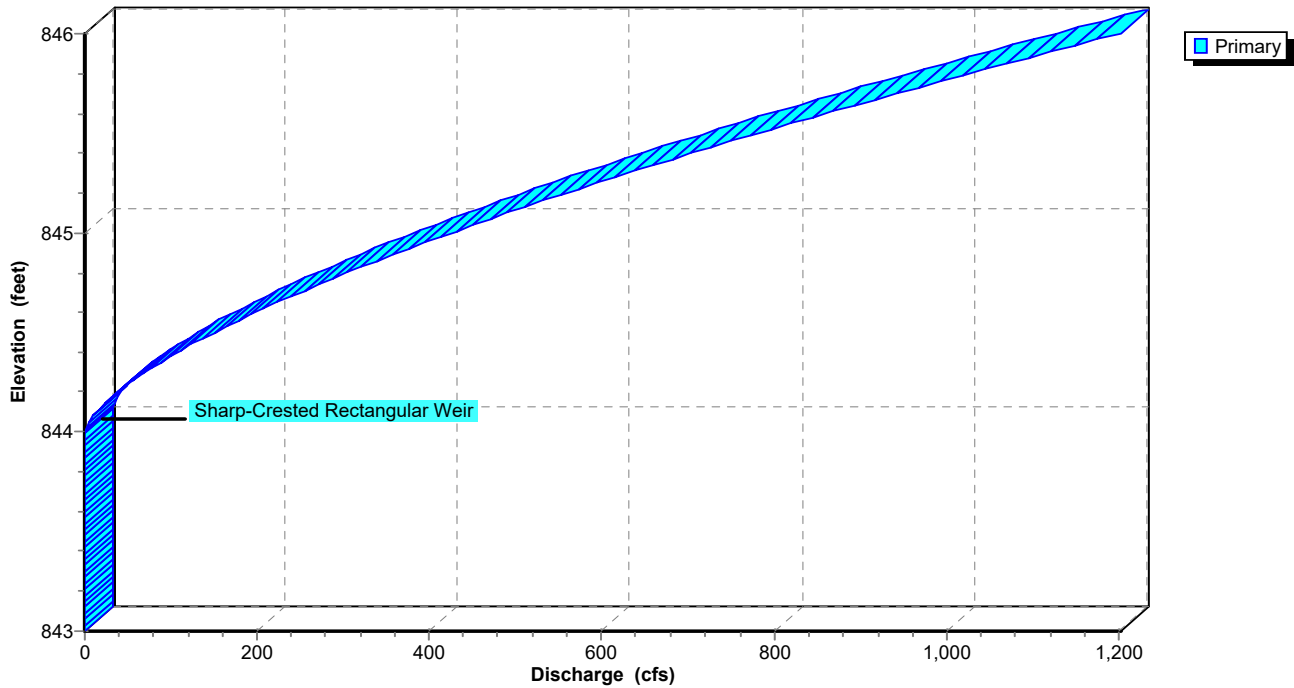

Pond P4A: Mine Ponds

Stage-Area-Storage

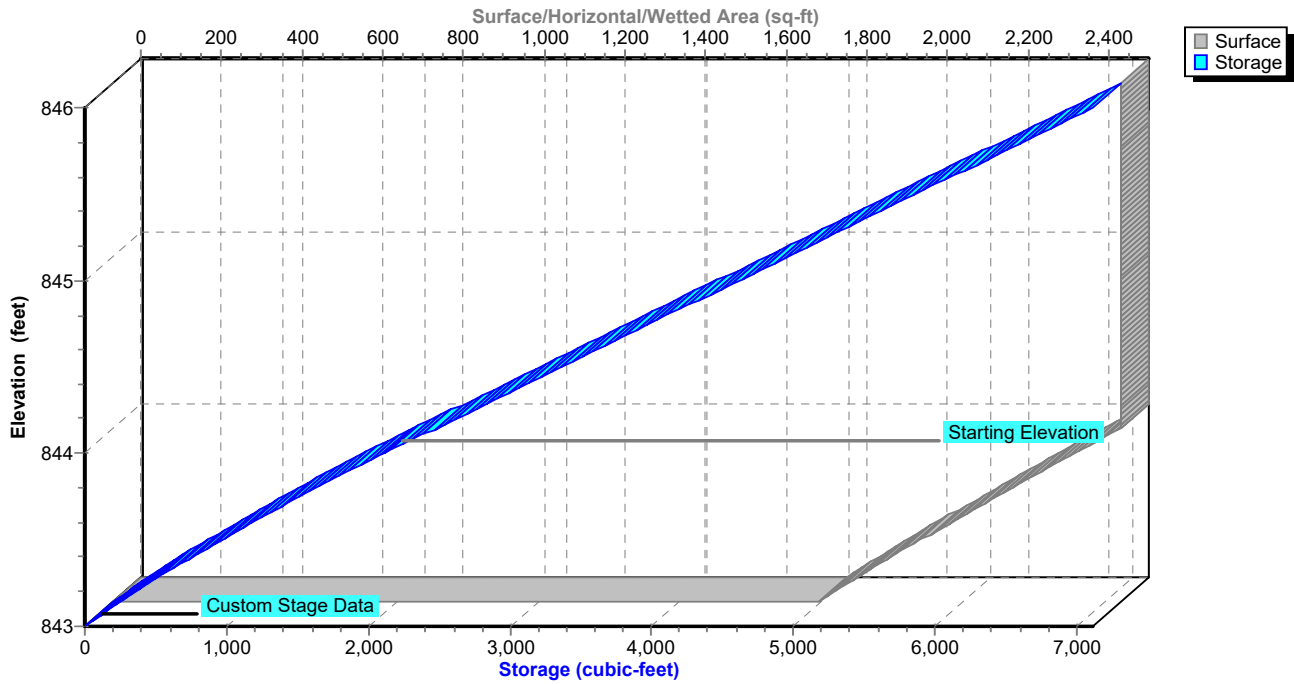

IGN Padua Ridge Existing v4 w culvert

Type II 24-hr 10-yr Rainfall=3.61"

Prepared by JMT

Printed 1/31/2022

HydroCAD® 10.00-20 s/n 02102 © 2017 HydroCAD Software Solutions LLC

Page 37

Hydrograph for Pond P4A: Mine Ponds

Time (hours)	Inflow (cfs)	Storage (cubic-feet)	Elevation (feet)	Primary (cfs)
0.05	0.00	2,114	844.00	0.00
2.55	0.00	2,114	844.00	0.00
5.05	0.00	2,114	844.00	0.00
7.55	0.00	2,114	844.00	0.00
10.05	0.17	2,121	844.00	0.16
12.55	3.93	2,222	844.04	3.97
15.05	1.45	2,169	844.02	1.45
17.55	0.96	2,154	844.02	0.96
20.05	0.66	2,141	844.01	0.66
22.55	0.60	2,139	844.01	0.60
25.05	0.00	2,114	844.00	0.00
27.55	0.00	2,114	844.00	0.00
30.05	0.00	2,114	844.00	0.00
32.55	0.00	2,114	844.00	0.00
35.05	0.00	2,114	844.00	0.00
37.55	0.00	2,114	844.00	0.00
40.05	0.00	2,114	844.00	0.00
42.55	0.00	2,114	844.00	0.00
45.05	0.00	2,114	844.00	0.00
47.55	0.00	2,114	844.00	0.00
50.05	0.00	2,114	844.00	0.00
52.55	0.00	2,114	844.00	0.00
55.05	0.00	2,114	844.00	0.00
57.55	0.00	2,114	844.00	0.00
60.05	0.00	2,114	844.00	0.00
62.55	0.00	2,114	844.00	0.00
65.05	0.00	2,114	844.00	0.00
67.55	0.00	2,114	844.00	0.00
70.05	0.00	2,114	844.00	0.00
72.55	0.00	2,114	844.00	0.00
75.05	0.00	2,114	844.00	0.00
77.55	0.00	2,114	844.00	0.00
80.05	0.00	2,114	844.00	0.00
82.55	0.00	2,114	844.00	0.00
85.05	0.00	2,114	844.00	0.00
87.55	0.00	2,114	844.00	0.00
90.05	0.00	2,114	844.00	0.00
92.55	0.00	2,114	844.00	0.00
95.05	0.00	2,114	844.00	0.00
97.55	0.00	2,114	844.00	0.00
100.05	0.00	2,114	844.00	0.00
102.55	0.00	2,114	844.00	0.00
105.05	0.00	2,114	844.00	0.00
107.55	0.00	2,114	844.00	0.00
110.05	0.00	2,114	844.00	0.00
112.55	0.00	2,114	844.00	0.00
115.05	0.00	2,114	844.00	0.00
117.55	0.00	2,114	844.00	0.00

Stage-Discharge for Pond P4A: Mine Ponds

Elevation (feet)	Primary (cfs)	Elevation (feet)	Primary (cfs)	Elevation (feet)	Primary (cfs)
843.00	0.00	844.04	3.40	845.08	477.12
843.02	0.00	844.06	6.25	845.10	490.43
843.04	0.00	844.08	9.62	845.12	503.87
843.06	0.00	844.10	13.44	845.14	517.43
843.08	0.00	844.12	17.67	845.16	531.10
843.10	0.00	844.14	22.27	845.18	544.90
843.12	0.00	844.16	27.21	845.20	558.81
843.14	0.00	844.18	32.46	845.22	572.84
843.16	0.00	844.20	38.02	845.24	586.98
843.18	0.00	844.22	43.87	845.26	601.24
843.20	0.00	844.24	49.98	845.28	615.61
843.22	0.00	844.26	56.36	845.30	630.10
843.24	0.00	844.28	62.98	845.32	644.69
843.26	0.00	844.30	69.85	845.34	659.40
843.28	0.00	844.32	76.95	845.36	674.22
843.30	0.00	844.34	84.28	845.38	689.14
843.32	0.00	844.36	91.82	845.40	704.18
843.34	0.00	844.38	99.58	845.42	719.32
843.36	0.00	844.40	107.54	845.44	734.57
843.38	0.00	844.42	115.71	845.46	749.93
843.40	0.00	844.44	124.07	845.48	765.39
843.42	0.00	844.46	132.63	845.50	780.96
843.44	0.00	844.48	141.37	845.52	796.63
843.46	0.00	844.50	150.30	845.54	812.40
843.48	0.00	844.52	159.40	845.56	828.28
843.50	0.00	844.54	168.69	845.58	844.26
843.52	0.00	844.56	178.14	845.60	860.34
843.54	0.00	844.58	187.77	845.62	876.52
843.56	0.00	844.60	197.57	845.64	892.81
843.58	0.00	844.62	207.53	845.66	909.19
843.60	0.00	844.64	217.65	845.68	925.67
843.62	0.00	844.66	227.93	845.70	942.25
843.64	0.00	844.68	238.37	845.72	958.92
843.66	0.00	844.70	248.96	845.74	975.70
843.68	0.00	844.72	259.71	845.76	992.57
843.70	0.00	844.74	270.61	845.78	1,009.53
843.72	0.00	844.76	281.65	845.80	1,026.60
843.74	0.00	844.78	292.84	845.82	1,043.75
843.76	0.00	844.80	304.18	845.84	1,061.01
843.78	0.00	844.82	315.65	845.86	1,078.35
843.80	0.00	844.84	327.27	845.88	1,095.79
843.82	0.00	844.86	339.03	845.90	1,113.32
843.84	0.00	844.88	350.93	845.92	1,130.95
843.86	0.00	844.90	362.96	845.94	1,148.67
843.88	0.00	844.92	375.12	845.96	1,166.47
843.90	0.00	844.94	387.42	845.98	1,184.37
843.92	0.00	844.96	399.85	846.00	1,202.36
843.94	0.00	844.98	412.41		
843.96	0.00	845.00	425.10		
843.98	0.00	845.02	437.92		
844.00	0.00	845.04	450.86		
844.02	1.20	845.06	463.93		

Stage-Area-Storage for Pond P4A: Mine Ponds

Elevation (feet)	Surface (sq-ft)	Storage (cubic-feet)	Elevation (feet)	Surface (sq-ft)	Storage (cubic-feet)
843.00	1,750	0	845.60	2,500	6,114
843.05	1,784	88	845.65	2,500	6,239
843.10	1,819	178	845.70	2,500	6,364
843.15	1,854	270	845.75	2,500	6,489
843.20	1,889	364	845.80	2,500	6,614
843.25	1,925	459	845.85	2,500	6,739
843.30	1,961	556	845.90	2,500	6,864
843.35	1,997	655	845.95	2,500	6,989
843.40	2,034	756	846.00	2,500	7,114
843.45	2,071	859			
843.50	2,108	963			
843.55	2,146	1,070			
843.60	2,184	1,178			
843.65	2,222	1,288			
843.70	2,261	1,400			
843.75	2,300	1,514			
843.80	2,339	1,630			
843.85	2,379	1,748			
843.90	2,419	1,868			
843.95	2,459	1,990			
844.00	2,500	2,114			
844.05	2,500	2,239			
844.10	2,500	2,364			
844.15	2,500	2,489			
844.20	2,500	2,614			
844.25	2,500	2,739			
844.30	2,500	2,864			
844.35	2,500	2,989			
844.40	2,500	3,114			
844.45	2,500	3,239			
844.50	2,500	3,364			
844.55	2,500	3,489			
844.60	2,500	3,614			
844.65	2,500	3,739			
844.70	2,500	3,864			
844.75	2,500	3,989			
844.80	2,500	4,114			
844.85	2,500	4,239			
844.90	2,500	4,364			
844.95	2,500	4,489			
845.00	2,500	4,614			
845.05	2,500	4,739			
845.10	2,500	4,864			
845.15	2,500	4,989			
845.20	2,500	5,114			
845.25	2,500	5,239			
845.30	2,500	5,364			
845.35	2,500	5,489			
845.40	2,500	5,614			
845.45	2,500	5,739			
845.50	2,500	5,864			
845.55	2,500	5,989			

IGN Padua Ridge Existing v4 w culvert

Type II 24-hr 10-yr Rainfall=3.61"

Prepared by JMT

Printed 1/31/2022

HydroCAD® 10.00-20 s/n 02102 © 2017 HydroCAD Software Solutions LLC

Page 40

Summary for Pond P4B: Mine Ponds

Inflow Area = 18.419 ac, 3.15% Impervious, Inflow Depth = 1.58" for 10-yr event
 Inflow = 56.75 cfs @ 11.94 hrs, Volume= 2.427 af
 Outflow = 56.46 cfs @ 11.94 hrs, Volume= 2.427 af, Atten= 1%, Lag= 0.2 min
 Primary = 56.46 cfs @ 11.94 hrs, Volume= 2.427 af

Routing by Stor-Ind method, Time Span= 0.05-120.00 hrs, dt= 0.05 hrs
 Starting Elev= 838.00' Surf.Area= 6,800 sf Storage= 5,003 cf
 Peak Elev= 838.14' @ 11.94 hrs Surf.Area= 7,002 sf Storage= 5,988 cf (986 cf above start)

Plug-Flow detention time= 35.7 min calculated for 2.313 af (95% of inflow)
 Center-of-Mass det. time= 0.6 min (837.4 - 836.8)

Volume	Invert	Avail.Storage	Storage Description
#1	837.00'	21,606 cf	Custom Stage Data (Conic) Listed below (Recalc)

Elevation (feet)	Surf.Area (sq-ft)	Inc.Store (cubic-feet)	Cum.Store (cubic-feet)	Wet.Area (sq-ft)
837.00	3,400	0	0	3,400
838.00	6,800	5,003	5,003	6,809
840.00	9,900	16,603	21,606	9,976

Device	Routing	Invert	Outlet Devices
#1	Primary	838.00'	320.0' long Sharp-Crested Rectangular Weir 0 End Contraction(s)

Primary OutFlow Max=54.09 cfs @ 11.94 hrs HW=838.14' (Free Discharge)

↑1=Sharp-Crested Rectangular Weir (Weir Controls 54.09 cfs @ 1.22 fps)

Pond P4B: Mine Ponds

Hydrograph

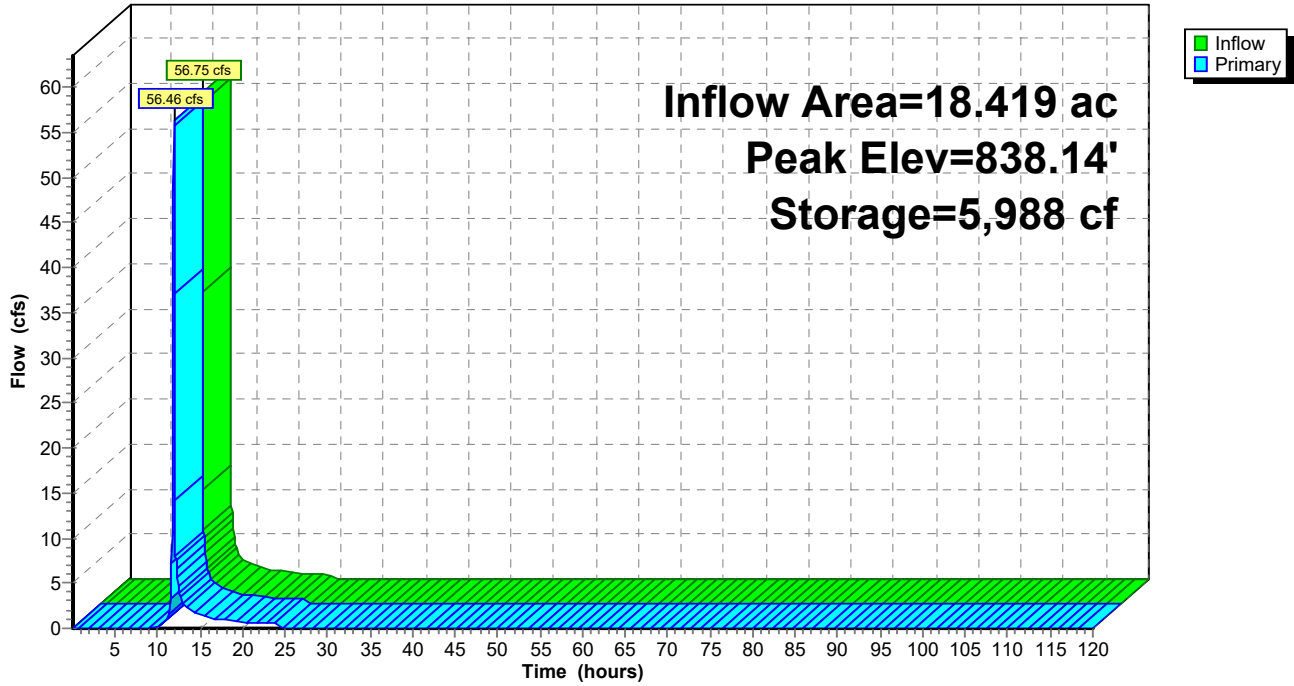

Pond P4B: Mine Ponds

Stage-Discharge

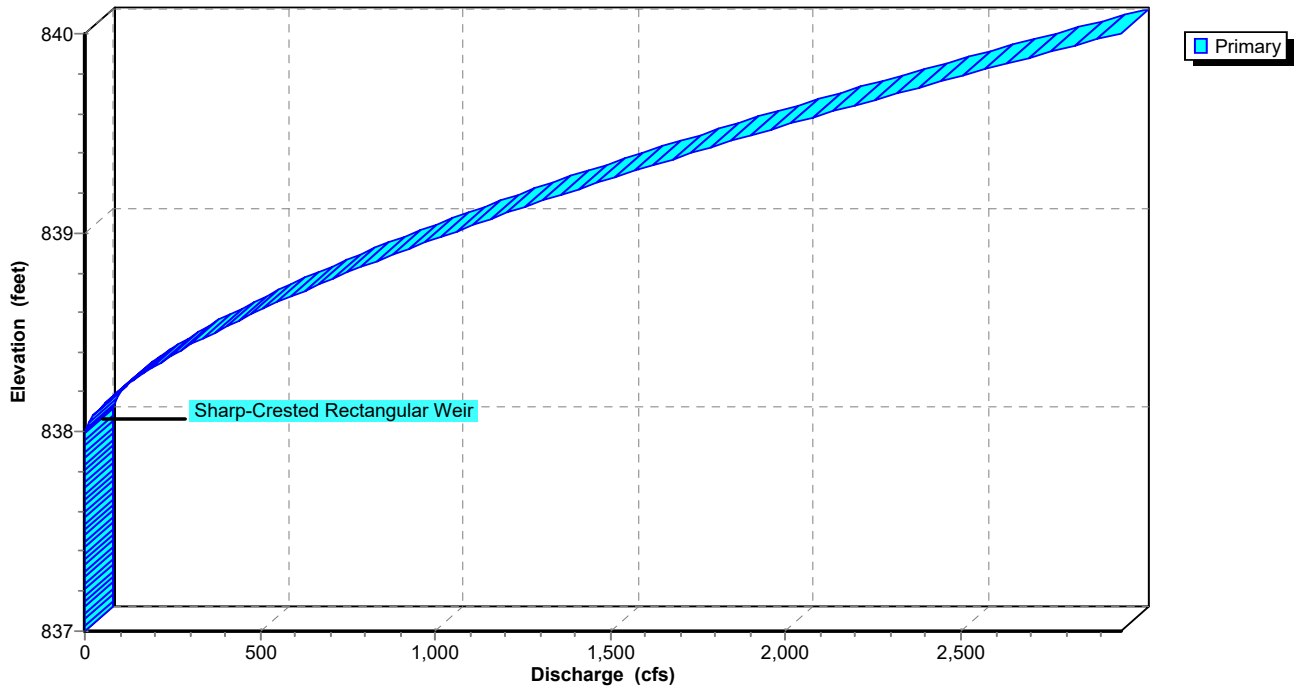

Pond P4B: Mine Ponds

Stage-Area-Storage

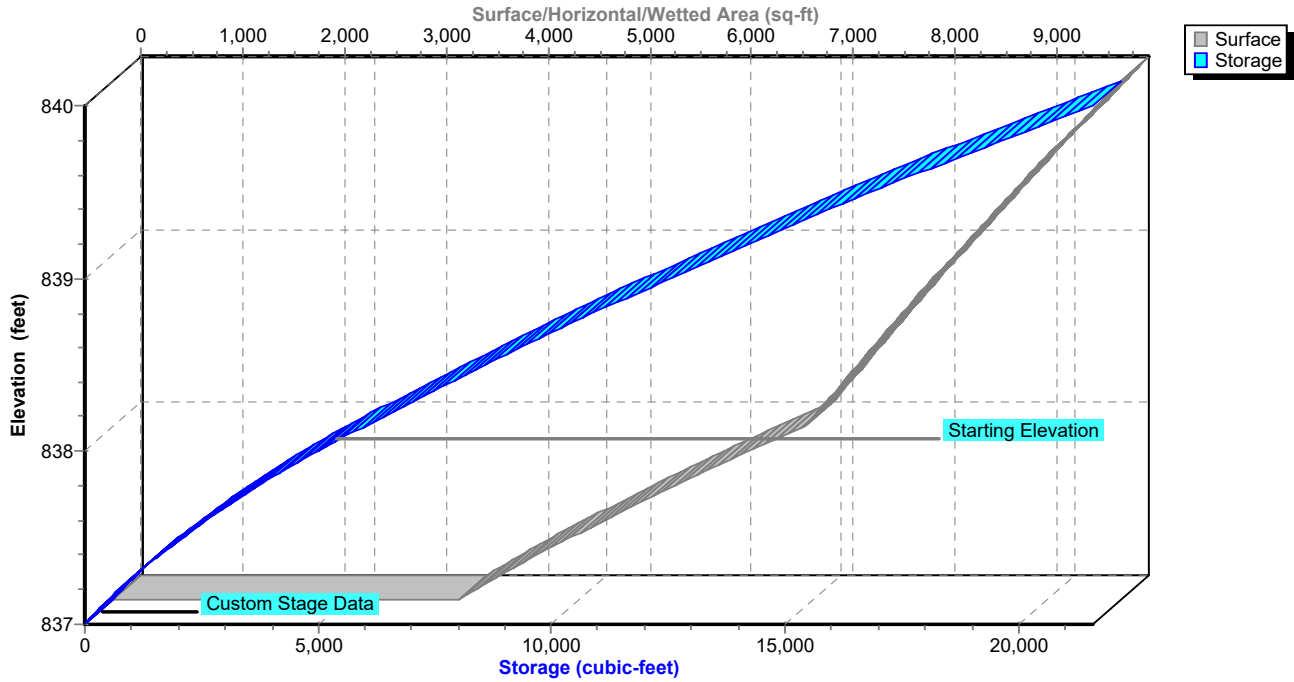

IGN Padua Ridge Existing v4 w culvert

Type II 24-hr 10-yr Rainfall=3.61"

Prepared by JMT

Printed 1/31/2022

HydroCAD® 10.00-20 s/n 02102 © 2017 HydroCAD Software Solutions LLC

Page 43

Hydrograph for Pond P4B: Mine Ponds

Time (hours)	Inflow (cfs)	Storage (cubic-feet)	Elevation (feet)	Primary (cfs)
0.05	0.00	5,003	838.00	0.00
2.55	0.00	5,003	838.00	0.00
5.05	0.00	5,003	838.00	0.00
7.55	0.00	5,003	838.00	0.00
10.05	0.16	5,010	838.00	0.16
12.55	3.97	5,164	838.02	4.00
15.05	1.45	5,070	838.01	1.45
17.55	0.96	5,047	838.01	0.96
20.05	0.66	5,033	838.00	0.66
22.55	0.60	5,031	838.00	0.60
25.05	0.00	5,003	838.00	0.00
27.55	0.00	5,003	838.00	0.00
30.05	0.00	5,003	838.00	0.00
32.55	0.00	5,003	838.00	0.00
35.05	0.00	5,003	838.00	0.00
37.55	0.00	5,003	838.00	0.00
40.05	0.00	5,003	838.00	0.00
42.55	0.00	5,003	838.00	0.00
45.05	0.00	5,003	838.00	0.00
47.55	0.00	5,003	838.00	0.00
50.05	0.00	5,003	838.00	0.00
52.55	0.00	5,003	838.00	0.00
55.05	0.00	5,003	838.00	0.00
57.55	0.00	5,003	838.00	0.00
60.05	0.00	5,003	838.00	0.00
62.55	0.00	5,003	838.00	0.00
65.05	0.00	5,003	838.00	0.00
67.55	0.00	5,003	838.00	0.00
70.05	0.00	5,003	838.00	0.00
72.55	0.00	5,003	838.00	0.00
75.05	0.00	5,003	838.00	0.00
77.55	0.00	5,003	838.00	0.00
80.05	0.00	5,003	838.00	0.00
82.55	0.00	5,003	838.00	0.00
85.05	0.00	5,003	838.00	0.00
87.55	0.00	5,003	838.00	0.00
90.05	0.00	5,003	838.00	0.00
92.55	0.00	5,003	838.00	0.00
95.05	0.00	5,003	838.00	0.00
97.55	0.00	5,003	838.00	0.00
100.05	0.00	5,003	838.00	0.00
102.55	0.00	5,003	838.00	0.00
105.05	0.00	5,003	838.00	0.00
107.55	0.00	5,003	838.00	0.00
110.05	0.00	5,003	838.00	0.00
112.55	0.00	5,003	838.00	0.00
115.05	0.00	5,003	838.00	0.00
117.55	0.00	5,003	838.00	0.00

Stage-Discharge for Pond P4B: Mine Ponds

Elevation (feet)	Primary (cfs)	Elevation (feet)	Primary (cfs)	Elevation (feet)	Primary (cfs)
837.00	0.00	838.04	8.37	839.08	1,174.45
837.02	0.00	838.06	15.38	839.10	1,207.22
837.04	0.00	838.08	23.68	839.12	1,240.29
837.06	0.00	838.10	33.09	839.14	1,273.66
837.08	0.00	838.12	43.50	839.16	1,307.33
837.10	0.00	838.14	54.81	839.18	1,341.28
837.12	0.00	838.16	66.97	839.20	1,375.53
837.14	0.00	838.18	79.91	839.22	1,410.06
837.16	0.00	838.20	93.59	839.24	1,444.87
837.18	0.00	838.22	107.98	839.26	1,479.97
837.20	0.00	838.24	123.03	839.28	1,515.35
837.22	0.00	838.26	138.73	839.30	1,551.00
837.24	0.00	838.28	155.04	839.32	1,586.93
837.26	0.00	838.30	171.94	839.34	1,623.14
837.28	0.00	838.32	189.42	839.36	1,659.61
837.30	0.00	838.34	207.45	839.38	1,696.35
837.32	0.00	838.36	226.02	839.40	1,733.36
837.34	0.00	838.38	245.12	839.42	1,770.64
837.36	0.00	838.40	264.72	839.44	1,808.18
837.38	0.00	838.42	284.82	839.46	1,845.98
837.40	0.00	838.44	305.41	839.48	1,884.04
837.42	0.00	838.46	326.46	839.50	1,922.36
837.44	0.00	838.48	347.98	839.52	1,960.93
837.46	0.00	838.50	369.96	839.54	1,999.76
837.48	0.00	838.52	392.38	839.56	2,038.85
837.50	0.00	838.54	415.23	839.58	2,078.18
837.52	0.00	838.56	438.51	839.60	2,117.76
837.54	0.00	838.58	462.21	839.62	2,157.60
837.56	0.00	838.60	486.32	839.64	2,197.68
837.58	0.00	838.62	510.84	839.66	2,238.00
837.60	0.00	838.64	535.76	839.68	2,278.57
837.62	0.00	838.66	561.07	839.70	2,319.38
837.64	0.00	838.68	586.76	839.72	2,360.43
837.66	0.00	838.70	612.84	839.74	2,401.72
837.68	0.00	838.72	639.29	839.76	2,443.24
837.70	0.00	838.74	666.11	839.78	2,485.01
837.72	0.00	838.76	693.30	839.80	2,527.01
837.74	0.00	838.78	720.84	839.82	2,569.24
837.76	0.00	838.80	748.74	839.84	2,611.71
837.78	0.00	838.82	777.00	839.86	2,654.40
837.80	0.00	838.84	805.59	839.88	2,697.33
837.82	0.00	838.86	834.54	839.90	2,740.49
837.84	0.00	838.88	863.82	839.92	2,783.87
837.86	0.00	838.90	893.43	839.94	2,827.49
837.88	0.00	838.92	923.38	839.96	2,871.32
837.90	0.00	838.94	953.65	839.98	2,915.38
837.92	0.00	838.96	984.25	840.00	2,959.67
837.94	0.00	838.98	1,015.17		
837.96	0.00	839.00	1,046.40		
837.98	0.00	839.02	1,077.95		
838.00	0.00	839.04	1,109.81		
838.02	2.96	839.06	1,141.97		

Stage-Area-Storage for Pond P4B: Mine Ponds

Elevation (feet)	Surface (sq-ft)	Storage (cubic-feet)	Elevation (feet)	Surface (sq-ft)	Storage (cubic-feet)
837.00	3,400	0	839.60	9,234	17,780
837.05	3,542	174	839.65	9,316	18,244
837.10	3,687	354	839.70	9,398	18,712
837.15	3,836	542	839.75	9,481	19,184
837.20	3,987	738	839.80	9,564	19,660
837.25	4,141	941	839.85	9,647	20,140
837.30	4,297	1,152	839.90	9,731	20,624
837.35	4,457	1,371	839.95	9,815	21,113
837.40	4,620	1,598	840.00	9,900	21,606
837.45	4,786	1,833			
837.50	4,954	2,076			
837.55	5,126	2,328			
837.60	5,300	2,589			
837.65	5,477	2,858			
837.70	5,657	3,137			
837.75	5,841	3,424			
837.80	6,027	3,721			
837.85	6,216	4,027			
837.90	6,407	4,342			
837.95	6,602	4,668			
838.00	6,800	5,003			
838.05	6,870	5,345			
838.10	6,941	5,690			
838.15	7,012	6,039			
838.20	7,084	6,391			
838.25	7,156	6,747			
838.30	7,228	7,107			
838.35	7,301	7,470			
838.40	7,374	7,837			
838.45	7,447	8,207			
838.50	7,521	8,581			
838.55	7,595	8,959			
838.60	7,669	9,341			
838.65	7,744	9,726			
838.70	7,819	10,115			
838.75	7,894	10,508			
838.80	7,970	10,905			
838.85	8,047	11,305			
838.90	8,123	11,709			
838.95	8,200	12,117			
839.00	8,277	12,529			
839.05	8,355	12,945			
839.10	8,433	13,365			
839.15	8,512	13,789			
839.20	8,590	14,216			
839.25	8,669	14,648			
839.30	8,749	15,083			
839.35	8,829	15,522			
839.40	8,909	15,966			
839.45	8,990	16,413			
839.50	9,071	16,865			
839.55	9,152	17,320			

Summary for Pond P4C: Mine Ponds

Inflow Area = 18.419 ac, 3.15% Impervious, Inflow Depth = 1.58" for 10-yr event
 Inflow = 56.46 cfs @ 11.94 hrs, Volume= 2.427 af
 Outflow = 1.19 cfs @ 15.87 hrs, Volume= 2.426 af, Atten= 98%, Lag= 235.8 min
 Primary = 1.19 cfs @ 15.87 hrs, Volume= 2.426 af

Routing by Stor-Ind method, Time Span= 0.05-120.00 hrs, dt= 0.05 hrs
 Starting Elev= 832.00' Surf.Area= 16,000 sf Storage= 12,610 cf
 Peak Elev= 834.92' @ 15.87 hrs Surf.Area= 31,125 sf Storage= 83,255 cf (70,645 cf above start)

Plug-Flow detention time= 1,330.8 min calculated for 2.137 af (88% of inflow)
 Center-of-Mass det. time= 1,120.5 min (1,957.8 - 837.4)

Volume	Invert	Avail.Storage	Storage Description	
#1	831.00'	118,924 cf	Custom Stage Data (Conic) Listed below (Recalc)	
Elevation (feet)	Surf.Area (sq-ft)	Inc.Store (cubic-feet)	Cum.Store (cubic-feet)	Wet.Area (sq-ft)
831.00	9,500	0	0	9,500
832.00	16,000	12,610	12,610	16,012
834.00	28,000	43,444	56,054	28,057
836.00	35,000	62,870	118,924	35,169

Device	Routing	Invert	Outlet Devices
#1	Primary	832.00'	24.0" Round Culvert L= 118.0' CPP, square edge headwall, Ke= 0.500 Inlet / Outlet Invert= 832.00' / 831.00' S= 0.0085 '/' Cc= 0.900 n= 0.012, Flow Area= 3.14 sf
#2	Device 1	832.00'	2.0" Vert. Orifice/Grate X 4.00 C= 0.600
#3	Device 1	834.80'	3.5' long x 0.50' rise Sharp-Crested Rectangular Weir 2 End Contraction(s)
#4	Device 1	835.30'	6.0' long Sharp-Crested Rectangular Weir 2 End Contraction(s)

Primary OutFlow Max=1.18 cfs @ 15.87 hrs HW=834.92' (Free Discharge)
 1=Culvert (Passes 1.18 cfs of 20.96 cfs potential flow)
 2=Orifice/Grate (Orifice Controls 0.71 cfs @ 8.11 fps)
 3=Sharp-Crested Rectangular Weir (Weir Controls 0.48 cfs @ 1.14 fps)
 4=Sharp-Crested Rectangular Weir (Controls 0.00 cfs)

Pond P4C: Mine Ponds

Hydrograph

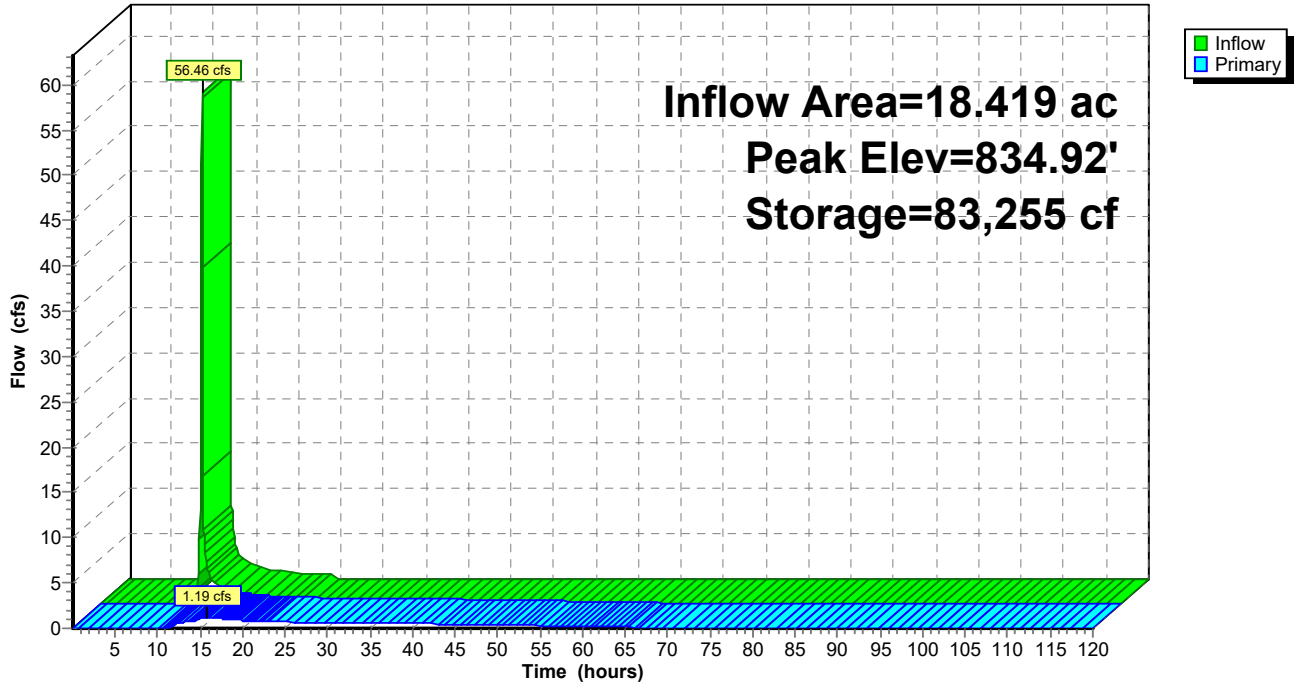

Pond P4C: Mine Ponds

Stage-Discharge

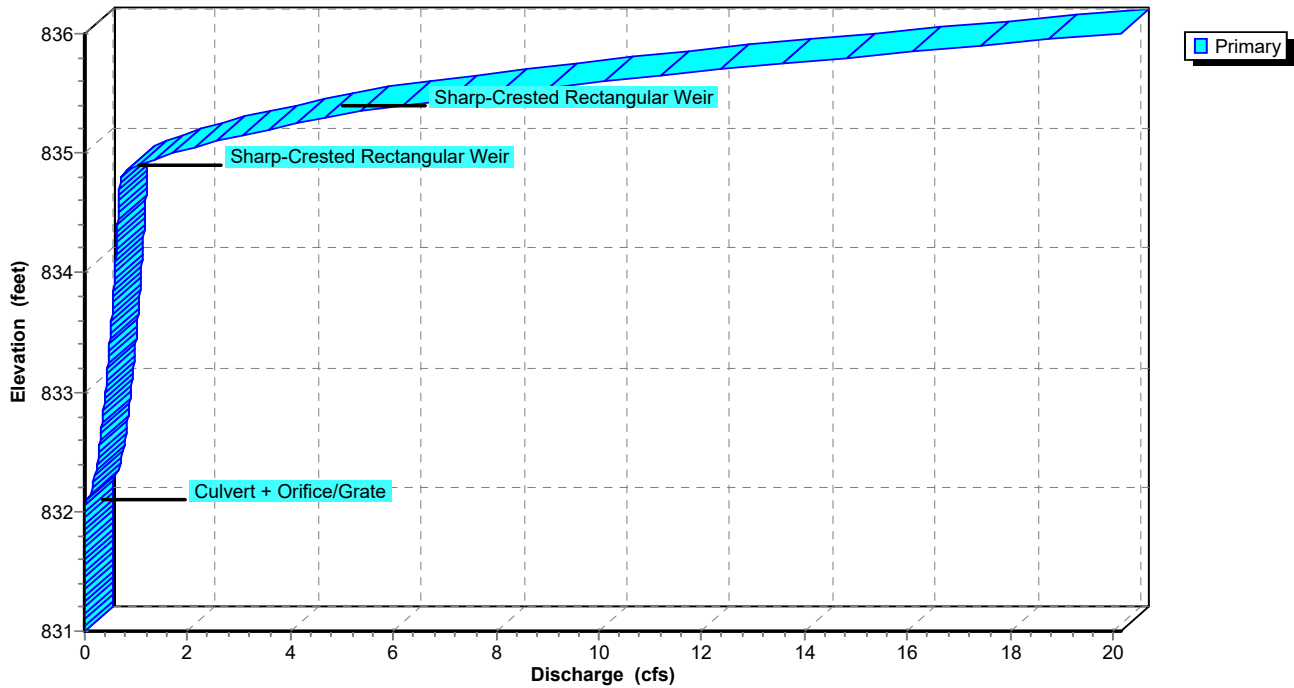

Pond P4C: Mine Ponds

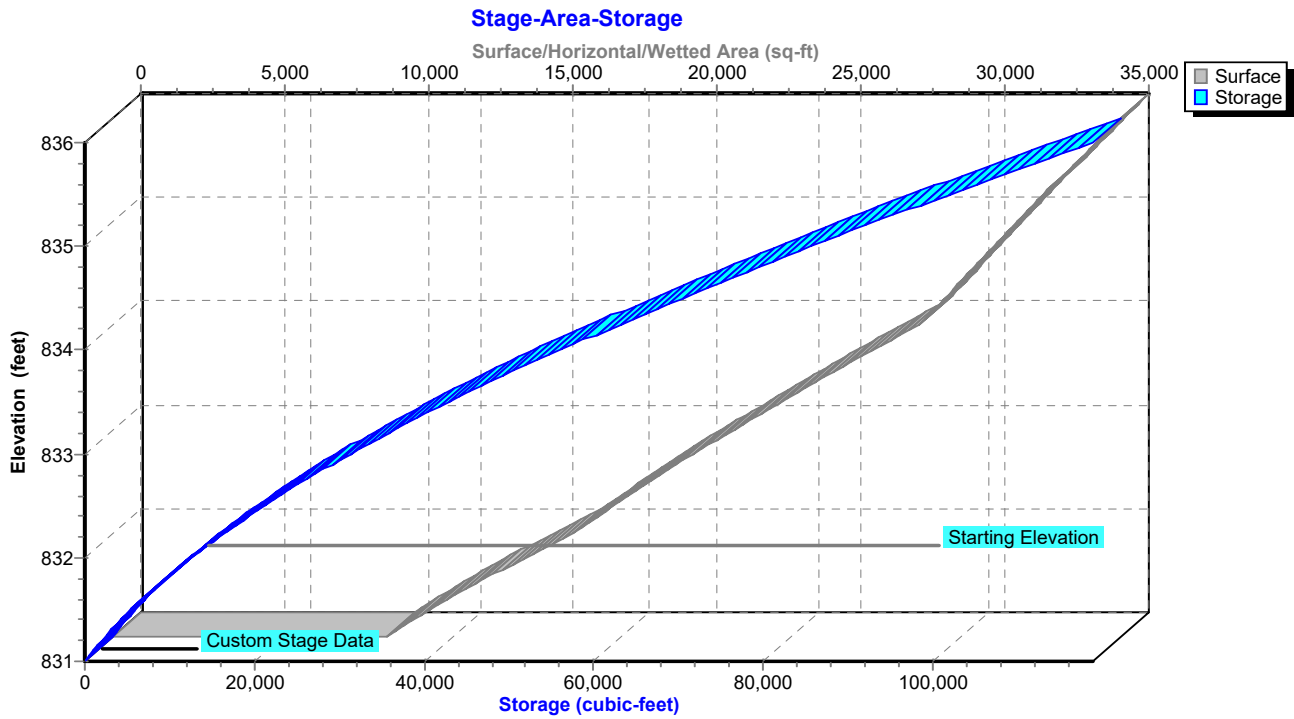

IGN Padua Ridge Existing v4 w culvert

Type II 24-hr 10-yr Rainfall=3.61"

Prepared by JMT

Printed 1/31/2022

HydroCAD® 10.00-20 s/n 02102 © 2017 HydroCAD Software Solutions LLC

Page 49

Hydrograph for Pond P4C: Mine Ponds

Time (hours)	Inflow (cfs)	Storage (cubic-feet)	Elevation (feet)	Primary (cfs)
0.05	0.00	12,610	832.00	0.00
2.55	0.00	12,610	832.00	0.00
5.05	0.00	12,610	832.00	0.00
7.55	0.00	12,610	832.00	0.00
10.05	0.16	12,783	832.01	0.00
12.55	4.00	69,874	834.48	0.65
15.05	1.45	82,784	834.91	1.10
17.55	0.96	82,713	834.90	1.08
20.05	0.66	81,237	834.86	0.85
22.55	0.60	79,896	834.81	0.72
25.05	0.00	76,826	834.71	0.68
27.55	0.00	70,814	834.51	0.65
30.05	0.00	65,042	834.32	0.63
32.55	0.00	59,517	834.12	0.60
35.05	0.00	54,243	833.93	0.57
37.55	0.00	49,229	833.75	0.54
40.05	0.00	44,487	833.56	0.51
42.55	0.00	40,030	833.38	0.48
45.05	0.00	35,872	833.20	0.44
47.55	0.00	32,027	833.03	0.41
50.05	0.00	28,511	832.87	0.37
52.55	0.00	25,339	832.71	0.33
55.05	0.00	22,526	832.57	0.29
57.55	0.00	20,088	832.44	0.25
60.05	0.00	18,041	832.32	0.21
62.55	0.00	16,399	832.23	0.16
65.05	0.00	15,173	832.16	0.11
67.55	0.00	14,376	832.11	0.07
70.05	0.00	13,910	832.08	0.04
72.55	0.00	13,626	832.06	0.02
75.05	0.00	13,451	832.05	0.02
77.55	0.00	13,335	832.04	0.01
80.05	0.00	13,236	832.04	0.01
82.55	0.00	13,151	832.03	0.01
85.05	0.00	13,077	832.03	0.01
87.55	0.00	13,014	832.03	0.01
90.05	0.00	12,959	832.02	0.01
92.55	0.00	12,911	832.02	0.00
95.05	0.00	12,870	832.02	0.00
97.55	0.00	12,835	832.01	0.00
100.05	0.00	12,804	832.01	0.00
102.55	0.00	12,778	832.01	0.00
105.05	0.00	12,755	832.01	0.00
107.55	0.00	12,735	832.01	0.00
110.05	0.00	12,718	832.01	0.00
112.55	0.00	12,703	832.01	0.00
115.05	0.00	12,690	832.01	0.00
117.55	0.00	12,679	832.00	0.00

IGN Padua Ridge Existing v4 w culvert

Type II 24-hr 10-yr Rainfall=3.61"

Prepared by JMT

Printed 1/31/2022

HydroCAD® 10.00-20 s/n 02102 © 2017 HydroCAD Software Solutions LLC

Page 50

Stage-Discharge for Pond P4C: Mine Ponds

Elevation (feet)	Primary (cfs)	Elevation (feet)	Primary (cfs)
831.00	0.00	833.60	0.52
831.05	0.00	833.65	0.53
831.10	0.00	833.70	0.53
831.15	0.00	833.75	0.54
831.20	0.00	833.80	0.55
831.25	0.00	833.85	0.56
831.30	0.00	833.90	0.57
831.35	0.00	833.95	0.57
831.40	0.00	834.00	0.58
831.45	0.00	834.05	0.59
831.50	0.00	834.10	0.60
831.55	0.00	834.15	0.60
831.60	0.00	834.20	0.61
831.65	0.00	834.25	0.62
831.70	0.00	834.30	0.63
831.75	0.00	834.35	0.63
831.80	0.00	834.40	0.64
831.85	0.00	834.45	0.65
831.90	0.00	834.50	0.65
831.95	0.00	834.55	0.66
832.00	0.00	834.60	0.67
832.05	0.01	834.65	0.67
832.10	0.06	834.70	0.68
832.15	0.11	834.75	0.69
832.20	0.14	834.80	0.69
832.25	0.17	834.85	0.83
832.30	0.20	834.90	1.07
832.35	0.22	834.95	1.37
832.40	0.24	835.00	1.73
832.45	0.25	835.05	2.13
832.50	0.27	835.10	2.58
832.55	0.29	835.15	3.06
832.60	0.30	835.20	3.57
832.65	0.32	835.25	4.11
832.70	0.33	835.30	4.68
832.75	0.34	835.35	5.39
832.80	0.36	835.40	6.20
832.85	0.37	835.45	7.09
832.90	0.38	835.50	8.04
832.95	0.39	835.55	9.05
833.00	0.40	835.60	10.11
833.05	0.41	835.65	11.22
833.10	0.42	835.70	12.38
833.15	0.43	835.75	13.58
833.20	0.44	835.80	14.82
833.25	0.45	835.85	16.10
833.30	0.46	835.90	17.42
833.35	0.47	835.95	18.77
833.40	0.48	836.00	20.16
833.45	0.49		
833.50	0.50		
833.55	0.51		

IGN Padua Ridge Existing v4 w culvert

Type II 24-hr 10-yr Rainfall=3.61"

Prepared by JMT

Printed 1/31/2022

HydroCAD® 10.00-20 s/n 02102 © 2017 HydroCAD Software Solutions LLC

Page 51

Stage-Area-Storage for Pond P4C: Mine Ponds

Elevation (feet)	Surface (sq-ft)	Storage (cubic-feet)	Elevation (feet)	Surface (sq-ft)	Storage (cubic-feet)
831.00	9,500	0	833.60	25,333	45,391
831.05	9,785	482	833.65	25,659	46,666
831.10	10,074	979	833.70	25,987	47,957
831.15	10,368	1,490	833.75	26,318	49,265
831.20	10,665	2,015	833.80	26,650	50,589
831.25	10,967	2,556	833.85	26,984	51,930
831.30	11,273	3,112	833.90	27,321	53,288
831.35	11,583	3,684	833.95	27,659	54,662
831.40	11,898	4,271	834.00	28,000	56,054
831.45	12,217	4,873	834.05	28,165	57,458
831.50	12,539	5,492	834.10	28,331	58,870
831.55	12,867	6,127	834.15	28,498	60,291
831.60	13,198	6,779	834.20	28,665	61,720
831.65	13,533	7,447	834.25	28,832	63,157
831.70	13,873	8,132	834.30	29,000	64,603
831.75	14,217	8,835	834.35	29,169	66,057
831.80	14,565	9,554	834.40	29,338	67,520
831.85	14,918	10,291	834.45	29,507	68,991
831.90	15,274	11,046	834.50	29,677	70,471
831.95	15,635	11,819	834.55	29,847	71,959
832.00	16,000	12,610	834.60	30,018	73,456
832.05	16,259	13,416	834.65	30,189	74,961
832.10	16,521	14,236	834.70	30,361	76,474
832.15	16,784	15,068	834.75	30,534	77,997
832.20	17,050	15,914	834.80	30,706	79,528
832.25	17,318	16,773	834.85	30,880	81,067
832.30	17,587	17,646	834.90	31,053	82,616
832.35	17,859	18,532	834.95	31,228	84,173
832.40	18,133	19,432	835.00	31,402	85,739
832.45	18,409	20,345	835.05	31,578	87,313
832.50	18,687	21,273	835.10	31,753	88,896
832.55	18,967	22,214	835.15	31,930	90,488
832.60	19,250	23,170	835.20	32,106	92,089
832.65	19,534	24,139	835.25	32,284	93,699
832.70	19,821	25,123	835.30	32,461	95,318
832.75	20,109	26,121	835.35	32,639	96,945
832.80	20,400	27,134	835.40	32,818	98,582
832.85	20,692	28,161	835.45	32,997	100,227
832.90	20,987	29,203	835.50	33,177	101,881
832.95	21,284	30,260	835.55	33,357	103,545
833.00	21,583	31,332	835.60	33,538	105,217
833.05	21,884	32,418	835.65	33,719	106,899
833.10	22,187	33,520	835.70	33,900	108,589
833.15	22,492	34,637	835.75	34,082	110,289
833.20	22,800	35,769	835.80	34,265	111,997
833.25	23,109	36,917	835.85	34,448	113,715
833.30	23,421	38,080	835.90	34,631	115,442
833.35	23,734	39,259	835.95	34,815	117,178
833.40	24,050	40,454	836.00	35,000	118,924
833.45	24,367	41,664			
833.50	24,687	42,890			
833.55	25,009	44,133			

IGN Padua Ridge Existing v4 w culvert

Type II 24-hr 25-yr Rainfall=4.39"

Prepared by JMT

Printed 1/31/2022

HydroCAD® 10.00-20 s/n 02102 © 2017 HydroCAD Software Solutions LLC

Page 52

Time span=0.05-120.00 hrs, dt=0.05 hrs, 2400 points
 Runoff by SCS TR-20 method, UH=SCS, Weighted-CN
 Reach routing by Stor-Ind+Trans method - Pond routing by Stor-Ind method

Subcatchment1: Area 1 Runoff Area=292,726 sf 0.00% Impervious Runoff Depth=0.64"
 Flow Length=830' Tc=13.1 min CN=54 Runoff=4.30 cfs 0.361 af

Subcatchment3: Area 3 Runoff Area=595,060 sf 0.00% Impervious Runoff Depth=0.02"
 Flow Length=1,110' Tc=3.9 min CN=35 Runoff=0.05 cfs 0.027 af

Subcatchment4: Mined Area Runoff Area=802,323 sf 3.15% Impervious Runoff Depth=2.20"
 Flow Length=675' Tc=2.6 min CN=78 Runoff=78.58 cfs 3.380 af

Subcatchment5: Area 5 and Upland Runoff Area=35.690 ac 0.00% Impervious Runoff Depth=0.02"
 Flow Length=2,527' Tc=73.4 min CN=35 Runoff=0.12 cfs 0.071 af

Subcatchment8: Downslope Area Runoff Area=1,317,715 sf 0.00% Impervious Runoff Depth=1.53"
 Flow Length=850' Tc=17.7 min CN=69 Runoff=52.79 cfs 3.849 af

Reach R1: Drainage Easement Avg. Flow Depth=2.17' Max Vel=6.60 fps Inflow=54.21 cfs 7.228 af
 n=0.030 L=2,109.0' S=0.0166 '/' Capacity=93.64 cfs Outflow=48.39 cfs 7.228 af

Pond P1: Infiltration Area Peak Elev=855.85' Storage=9,623 cf Inflow=4.30 cfs 0.361 af
 Outflow=0.14 cfs 0.361 af

Pond P3: Infiltration Area Peak Elev=862.01' Storage=78 cf Inflow=0.05 cfs 0.027 af
 Outflow=0.05 cfs 0.027 af

Pond P4A: Mine Ponds Peak Elev=844.32' Storage=2,926 cf Inflow=78.58 cfs 3.380 af
 Outflow=78.42 cfs 3.380 af

Pond P4B: Mine Ponds Peak Elev=838.18' Storage=6,231 cf Inflow=78.42 cfs 3.380 af
 Outflow=78.09 cfs 3.380 af

Pond P4C: Mine Ponds Peak Elev=835.25' Storage=93,601 cf Inflow=78.09 cfs 3.380 af
 Outflow=4.08 cfs 3.379 af

Total Runoff Area = 104.740 ac Runoff Volume = 7.687 af Average Runoff Depth = 0.88"
99.45% Pervious = 104.159 ac 0.55% Impervious = 0.581 ac

Summary for Subcatchment 1: Area 1

Runoff = 4.30 cfs @ 12.09 hrs, Volume= 0.361 af, Depth= 0.64"

Runoff by SCS TR-20 method, UH=SCS, Weighted-CN, Time Span= 0.05-120.00 hrs, dt= 0.05 hrs
 Type II 24-hr 25-yr Rainfall=4.39"

Area (sf)	CN	Description
50,010	85	Gravel roads, HSG B
151,324	58	Woods/grass comb., Good, HSG B
91,392	30	Woods, Good, HSG A
292,726	54	Weighted Average
292,726		100.00% Pervious Area

Tc (min)	Length (feet)	Slope (ft/ft)	Velocity (ft/sec)	Capacity (cfs)	Description
8.5	100	0.3000	0.20		Sheet Flow, Woods: Light underbrush n= 0.400 P2= 2.35"
3.1	372	0.1600	2.00		Shallow Concentrated Flow, Woodland Kv= 5.0 fps
1.5	358	0.0600	3.94		Shallow Concentrated Flow, Unpaved Kv= 16.1 fps
13.1	830	Total			

Subcatchment 1: Area 1

Hydrograph

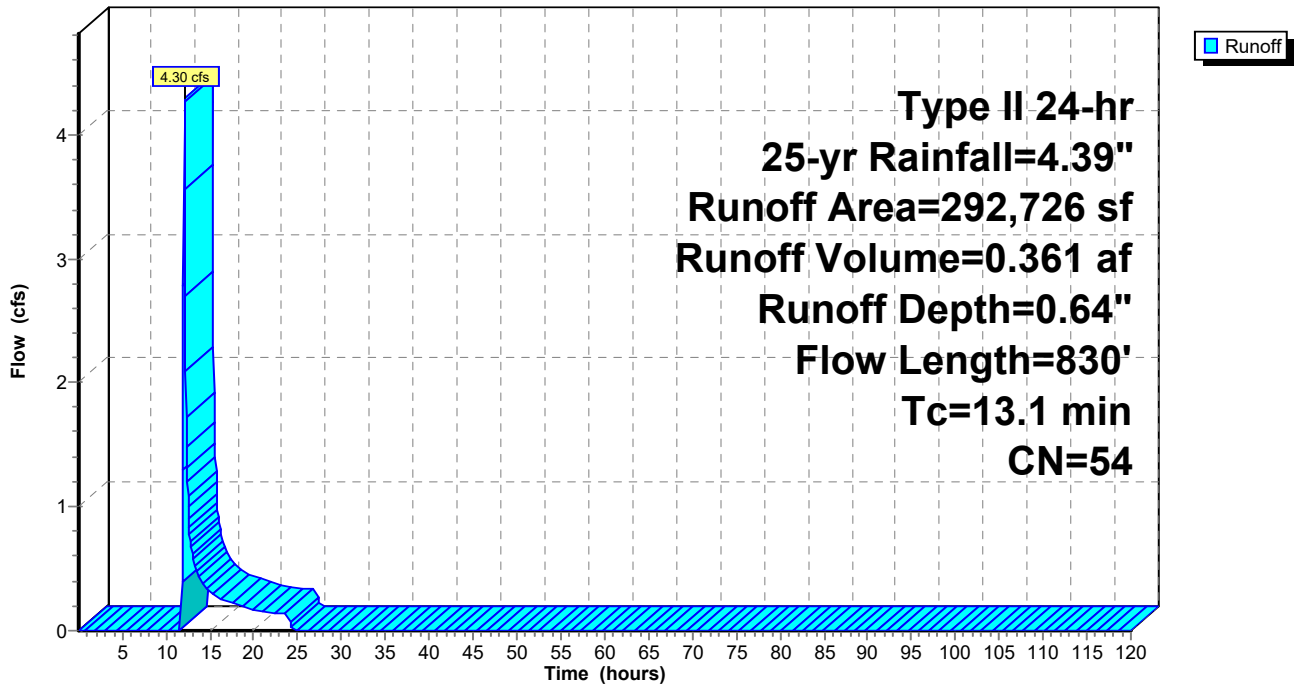

IGN Padua Ridge Existing v4 w culvert

Prepared by JMT

HydroCAD® 10.00-20 s/n 02102 © 2017 HydroCAD Software Solutions LLC

Type II 24-hr 25-yr Rainfall=4.39"

Printed 1/31/2022

Page 54

Hydrograph for Subcatchment 1: Area 1

Time (hours)	Precip. (inches)	Excess (inches)	Runoff (cfs)
0.05	0.00	0.00	0.00
2.55	0.13	0.00	0.00
5.05	0.28	0.00	0.00
7.55	0.48	0.00	0.00
10.05	0.80	0.00	0.00
12.55	3.25	0.24	1.00
15.05	3.75	0.40	0.32
17.55	4.01	0.49	0.22
20.05	4.18	0.56	0.16
22.55	4.32	0.61	0.15
25.05	4.39	0.64	0.00
27.55	4.39	0.64	0.00
30.05	4.39	0.64	0.00
32.55	4.39	0.64	0.00
35.05	4.39	0.64	0.00
37.55	4.39	0.64	0.00
40.05	4.39	0.64	0.00
42.55	4.39	0.64	0.00
45.05	4.39	0.64	0.00
47.55	4.39	0.64	0.00
50.05	4.39	0.64	0.00
52.55	4.39	0.64	0.00
55.05	4.39	0.64	0.00
57.55	4.39	0.64	0.00
60.05	4.39	0.64	0.00
62.55	4.39	0.64	0.00
65.05	4.39	0.64	0.00
67.55	4.39	0.64	0.00
70.05	4.39	0.64	0.00
72.55	4.39	0.64	0.00
75.05	4.39	0.64	0.00
77.55	4.39	0.64	0.00
80.05	4.39	0.64	0.00
82.55	4.39	0.64	0.00
85.05	4.39	0.64	0.00
87.55	4.39	0.64	0.00
90.05	4.39	0.64	0.00
92.55	4.39	0.64	0.00
95.05	4.39	0.64	0.00
97.55	4.39	0.64	0.00
100.05	4.39	0.64	0.00
102.55	4.39	0.64	0.00
105.05	4.39	0.64	0.00
107.55	4.39	0.64	0.00
110.05	4.39	0.64	0.00
112.55	4.39	0.64	0.00
115.05	4.39	0.64	0.00
117.55	4.39	0.64	0.00

Summary for Subcatchment 3: Area 3

Runoff = 0.05 cfs @ 23.95 hrs, Volume= 0.027 af, Depth= 0.02"

Runoff by SCS TR-20 method, UH=SCS, Weighted-CN, Time Span= 0.05-120.00 hrs, dt= 0.05 hrs
Type II 24-hr 25-yr Rainfall=4.39"

Area (sf)	CN	Description
45,301	85	Gravel roads, HSG B
25,552	58	Woods/grass comb., Good, HSG B
524,207	30	Woods, Good, HSG A
595,060	35	Weighted Average
595,060		100.00% Pervious Area

Tc (min)	Length (feet)	Slope (ft/ft)	Velocity (ft/sec)	Capacity (cfs)	Description
0.7	100	0.1000	2.24		Sheet Flow, Smooth surfaces n= 0.011 P2= 2.35"
3.2	1,010	0.1100	5.34		Shallow Concentrated Flow, Unpaved Kv= 16.1 fps
3.9	1,110	Total			

Subcatchment 3: Area 3

Hydrograph

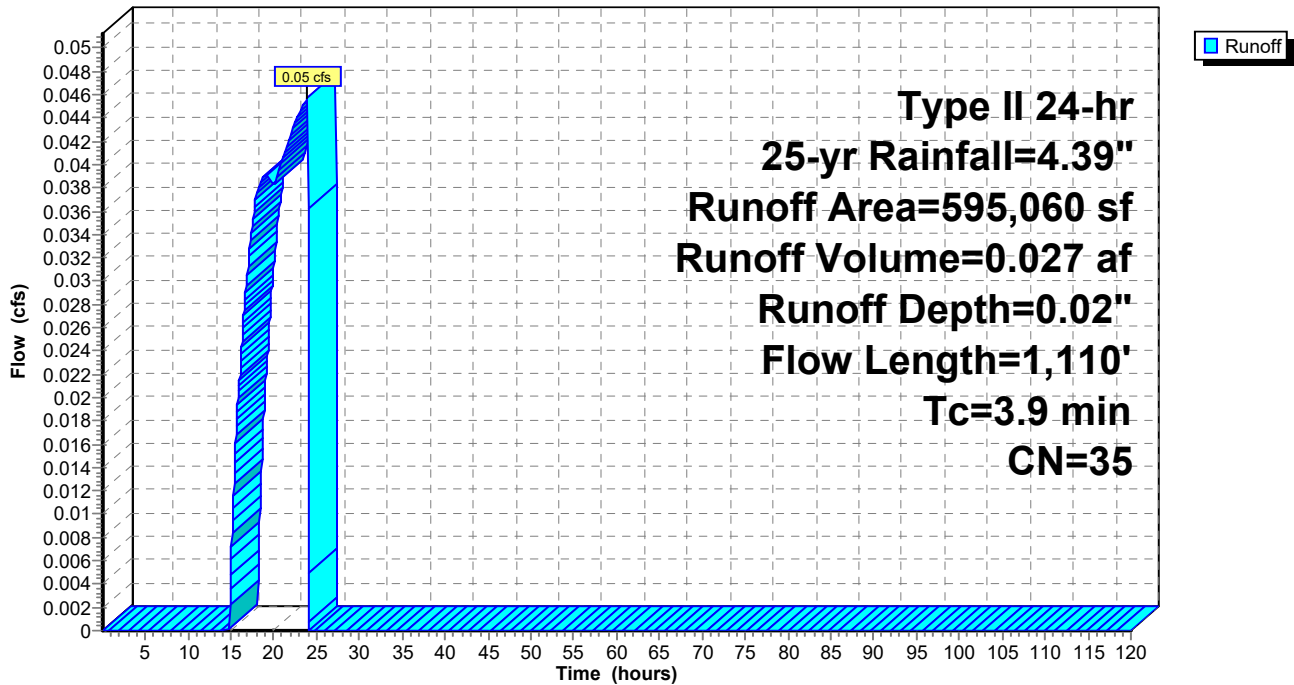

IGN Padua Ridge Existing v4 w culvert

Type II 24-hr 25-yr Rainfall=4.39"

Prepared by JMT

Printed 1/31/2022

HydroCAD® 10.00-20 s/n 02102 © 2017 HydroCAD Software Solutions LLC

Page 56

Hydrograph for Subcatchment 3: Area 3

Time (hours)	Precip. (inches)	Excess (inches)	Runoff (cfs)
0.05	0.00	0.00	0.00
2.55	0.13	0.00	0.00
5.05	0.28	0.00	0.00
7.55	0.48	0.00	0.00
10.05	0.80	0.00	0.00
12.55	3.25	0.00	0.00
15.05	3.75	0.00	0.01
17.55	4.01	0.00	0.04
20.05	4.18	0.01	0.04
22.55	4.32	0.02	0.04
25.05	4.39	0.02	0.00
27.55	4.39	0.02	0.00
30.05	4.39	0.02	0.00
32.55	4.39	0.02	0.00
35.05	4.39	0.02	0.00
37.55	4.39	0.02	0.00
40.05	4.39	0.02	0.00
42.55	4.39	0.02	0.00
45.05	4.39	0.02	0.00
47.55	4.39	0.02	0.00
50.05	4.39	0.02	0.00
52.55	4.39	0.02	0.00
55.05	4.39	0.02	0.00
57.55	4.39	0.02	0.00
60.05	4.39	0.02	0.00
62.55	4.39	0.02	0.00
65.05	4.39	0.02	0.00
67.55	4.39	0.02	0.00
70.05	4.39	0.02	0.00
72.55	4.39	0.02	0.00
75.05	4.39	0.02	0.00
77.55	4.39	0.02	0.00
80.05	4.39	0.02	0.00
82.55	4.39	0.02	0.00
85.05	4.39	0.02	0.00
87.55	4.39	0.02	0.00
90.05	4.39	0.02	0.00
92.55	4.39	0.02	0.00
95.05	4.39	0.02	0.00
97.55	4.39	0.02	0.00
100.05	4.39	0.02	0.00
102.55	4.39	0.02	0.00
105.05	4.39	0.02	0.00
107.55	4.39	0.02	0.00
110.05	4.39	0.02	0.00
112.55	4.39	0.02	0.00
115.05	4.39	0.02	0.00
117.55	4.39	0.02	0.00

IGN Padua Ridge Existing v4 w culvert

Type II 24-hr 25-yr Rainfall=4.39"

Prepared by JMT

Printed 1/31/2022

HydroCAD® 10.00-20 s/n 02102 © 2017 HydroCAD Software Solutions LLC

Page 57

Summary for Subcatchment 4: Mined Area

Runoff = 78.58 cfs @ 11.93 hrs, Volume= 3.380 af, Depth= 2.20"

Runoff by SCS TR-20 method, UH=SCS, Weighted-CN, Time Span= 0.05-120.00 hrs, dt= 0.05 hrs
 Type II 24-hr 25-yr Rainfall=4.39"

Area (sf)	CN	Description
777,023	77	Newly graded area, HSG A
25,300	98	Water Surface, HSG A
802,323	78	Weighted Average
777,023		96.85% Pervious Area
25,300		3.15% Impervious Area

Tc (min)	Length (feet)	Slope (ft/ft)	Velocity (ft/sec)	Capacity (cfs)	Description
0.4	100	0.3500	3.70		Sheet Flow, Smooth surfaces n= 0.011 P2= 2.35"
0.2	135	0.3300	9.25		Shallow Concentrated Flow, Unpaved Kv= 16.1 fps
1.7	290	0.0300	2.79		Shallow Concentrated Flow, Unpaved Kv= 16.1 fps
0.3	150	0.2700	8.37		Shallow Concentrated Flow, Unpaved Kv= 16.1 fps
2.6	675	Total			

Subcatchment 4: Mined Area

Hydrograph

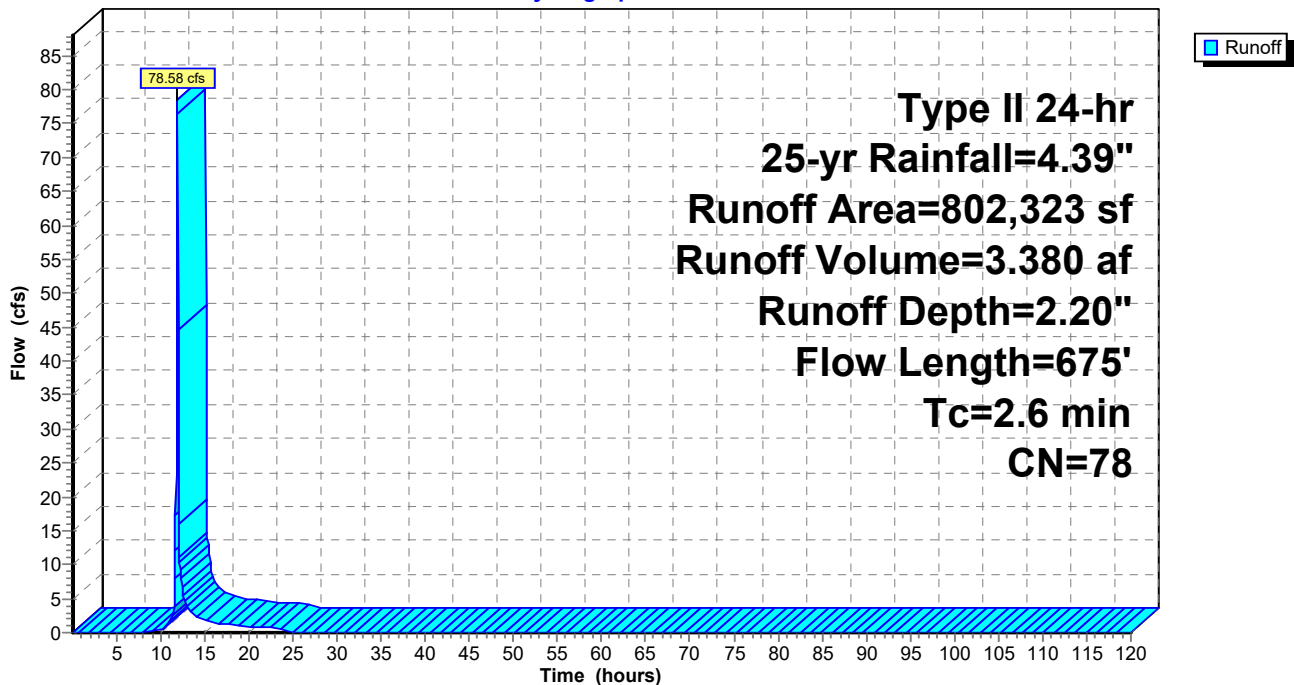

IGN Padua Ridge Existing v4 w culvert

Type II 24-hr 25-yr Rainfall=4.39"

Prepared by JMT

Printed 1/31/2022

HydroCAD® 10.00-20 s/n 02102 © 2017 HydroCAD Software Solutions LLC

Page 58

Hydrograph for Subcatchment 4: Mined Area

Time (hours)	Precip. (inches)	Excess (inches)	Runoff (cfs)
0.05	0.00	0.00	0.00
2.55	0.13	0.00	0.00
5.05	0.28	0.00	0.00
7.55	0.48	0.00	0.00
10.05	0.80	0.02	0.48
12.55	3.25	1.31	5.25
15.05	3.75	1.69	1.90
17.55	4.01	1.89	1.25
20.05	4.18	2.03	0.86
22.55	4.32	2.14	0.78
25.05	4.39	2.20	0.00
27.55	4.39	2.20	0.00
30.05	4.39	2.20	0.00
32.55	4.39	2.20	0.00
35.05	4.39	2.20	0.00
37.55	4.39	2.20	0.00
40.05	4.39	2.20	0.00
42.55	4.39	2.20	0.00
45.05	4.39	2.20	0.00
47.55	4.39	2.20	0.00
50.05	4.39	2.20	0.00
52.55	4.39	2.20	0.00
55.05	4.39	2.20	0.00
57.55	4.39	2.20	0.00
60.05	4.39	2.20	0.00
62.55	4.39	2.20	0.00
65.05	4.39	2.20	0.00
67.55	4.39	2.20	0.00
70.05	4.39	2.20	0.00
72.55	4.39	2.20	0.00
75.05	4.39	2.20	0.00
77.55	4.39	2.20	0.00
80.05	4.39	2.20	0.00
82.55	4.39	2.20	0.00
85.05	4.39	2.20	0.00
87.55	4.39	2.20	0.00
90.05	4.39	2.20	0.00
92.55	4.39	2.20	0.00
95.05	4.39	2.20	0.00
97.55	4.39	2.20	0.00
100.05	4.39	2.20	0.00
102.55	4.39	2.20	0.00
105.05	4.39	2.20	0.00
107.55	4.39	2.20	0.00
110.05	4.39	2.20	0.00
112.55	4.39	2.20	0.00
115.05	4.39	2.20	0.00
117.55	4.39	2.20	0.00

Summary for Subcatchment 5: Area 5 and Upland

Runoff = 0.12 cfs @ 24.18 hrs, Volume= 0.071 af, Depth= 0.02"

Runoff by SCS TR-20 method, UH=SCS, Weighted-CN, Time Span= 0.05-120.00 hrs, dt= 0.05 hrs
 Type II 24-hr 25-yr Rainfall=4.39"

Area (ac)	CN	Description
18.760	39	Pasture/grassland/range, Good, HSG A
16.930	30	Woods, Good, HSG A
35.690	35	Weighted Average
35.690		100.00% Pervious Area

Tc (min)	Length (feet)	Slope (ft/ft)	Velocity (ft/sec)	Capacity (cfs)	Description
16.1	100	0.0600	0.10		Sheet Flow, Woods: Light underbrush n= 0.400 P2= 2.35"
46.5	1,972	0.0200	0.71		Shallow Concentrated Flow, Woodland Kv= 5.0 fps
10.8	455	0.0100	0.70		Shallow Concentrated Flow, Short Grass Pasture Kv= 7.0 fps
73.4	2,527	Total			

Subcatchment 5: Area 5 and Upland

Hydrograph

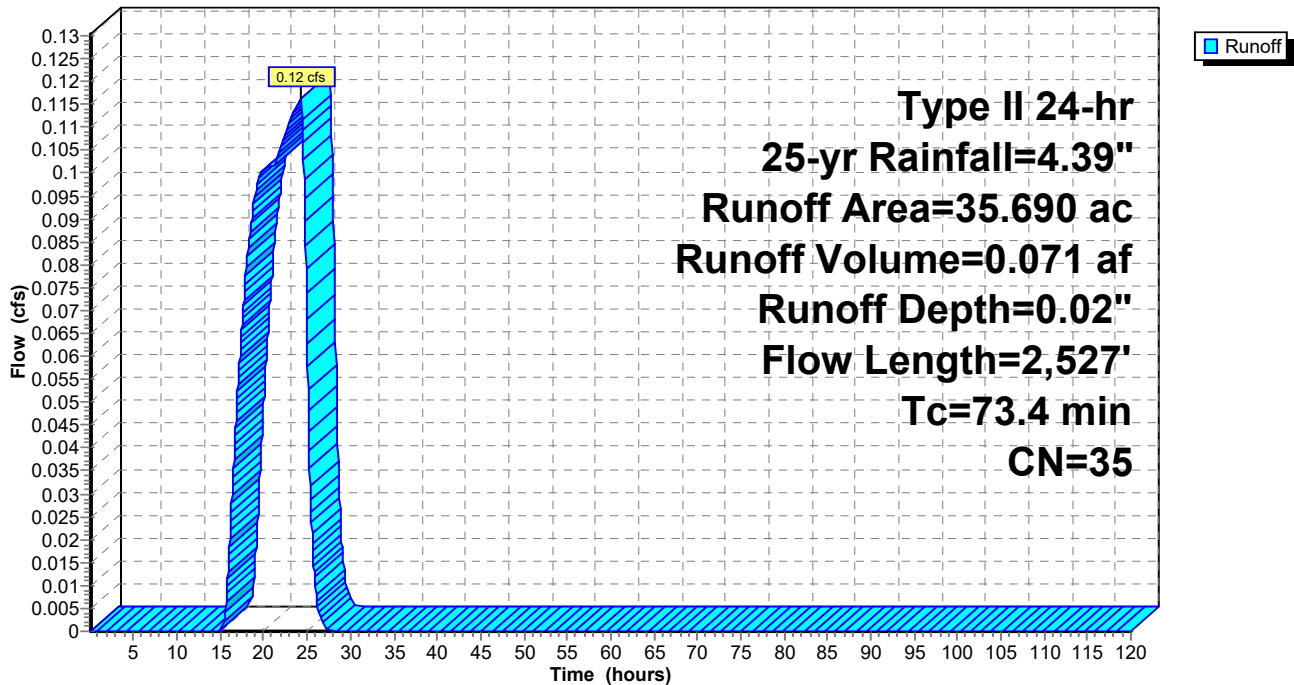

IGN Padua Ridge Existing v4 w culvert

Type II 24-hr 25-yr Rainfall=4.39"

Prepared by JMT

Printed 1/31/2022

HydroCAD® 10.00-20 s/n 02102 © 2017 HydroCAD Software Solutions LLC

Page 60

Hydrograph for Subcatchment 5: Area 5 and Upland

Time (hours)	Precip. (inches)	Excess (inches)	Runoff (cfs)
0.05	0.00	0.00	0.00
2.55	0.13	0.00	0.00
5.05	0.28	0.00	0.00
7.55	0.48	0.00	0.00
10.05	0.80	0.00	0.00
12.55	3.25	0.00	0.00
15.05	3.75	0.00	0.00
17.55	4.01	0.00	0.07
20.05	4.18	0.01	0.10
22.55	4.32	0.02	0.11
25.05	4.39	0.02	0.06
27.55	4.39	0.02	0.00
30.05	4.39	0.02	0.00
32.55	4.39	0.02	0.00
35.05	4.39	0.02	0.00
37.55	4.39	0.02	0.00
40.05	4.39	0.02	0.00
42.55	4.39	0.02	0.00
45.05	4.39	0.02	0.00
47.55	4.39	0.02	0.00
50.05	4.39	0.02	0.00
52.55	4.39	0.02	0.00
55.05	4.39	0.02	0.00
57.55	4.39	0.02	0.00
60.05	4.39	0.02	0.00
62.55	4.39	0.02	0.00
65.05	4.39	0.02	0.00
67.55	4.39	0.02	0.00
70.05	4.39	0.02	0.00
72.55	4.39	0.02	0.00
75.05	4.39	0.02	0.00
77.55	4.39	0.02	0.00
80.05	4.39	0.02	0.00
82.55	4.39	0.02	0.00
85.05	4.39	0.02	0.00
87.55	4.39	0.02	0.00
90.05	4.39	0.02	0.00
92.55	4.39	0.02	0.00
95.05	4.39	0.02	0.00
97.55	4.39	0.02	0.00
100.05	4.39	0.02	0.00
102.55	4.39	0.02	0.00
105.05	4.39	0.02	0.00
107.55	4.39	0.02	0.00
110.05	4.39	0.02	0.00
112.55	4.39	0.02	0.00
115.05	4.39	0.02	0.00
117.55	4.39	0.02	0.00

Summary for Subcatchment 8: Downslope Area

Runoff = 52.79 cfs @ 12.11 hrs, Volume= 3.849 af, Depth= 1.53"

Runoff by SCS TR-20 method, UH=SCS, Weighted-CN, Time Span= 0.05-120.00 hrs, dt= 0.05 hrs
 Type II 24-hr 25-yr Rainfall=4.39"

Area (sf)	CN	Description
224,307	32	Woods/grass comb., Good, HSG A
168,185	58	Woods/grass comb., Good, HSG B
40,548	85	Gravel roads, HSG B
884,675	79	Woods/grass comb., Good, HSG D
1,317,715	69	Weighted Average
1,317,715		100.00% Pervious Area

Tc (min)	Length (feet)	Slope (ft/ft)	Velocity (ft/sec)	Capacity (cfs)	Description
11.2	100	0.1500	0.15		Sheet Flow, Woods: Light underbrush n= 0.400 P2= 2.35"
6.5	750	0.1460	1.91		Shallow Concentrated Flow, Woodland Kv= 5.0 fps
17.7	850	Total			

Subcatchment 8: Downslope Area

Hydrograph

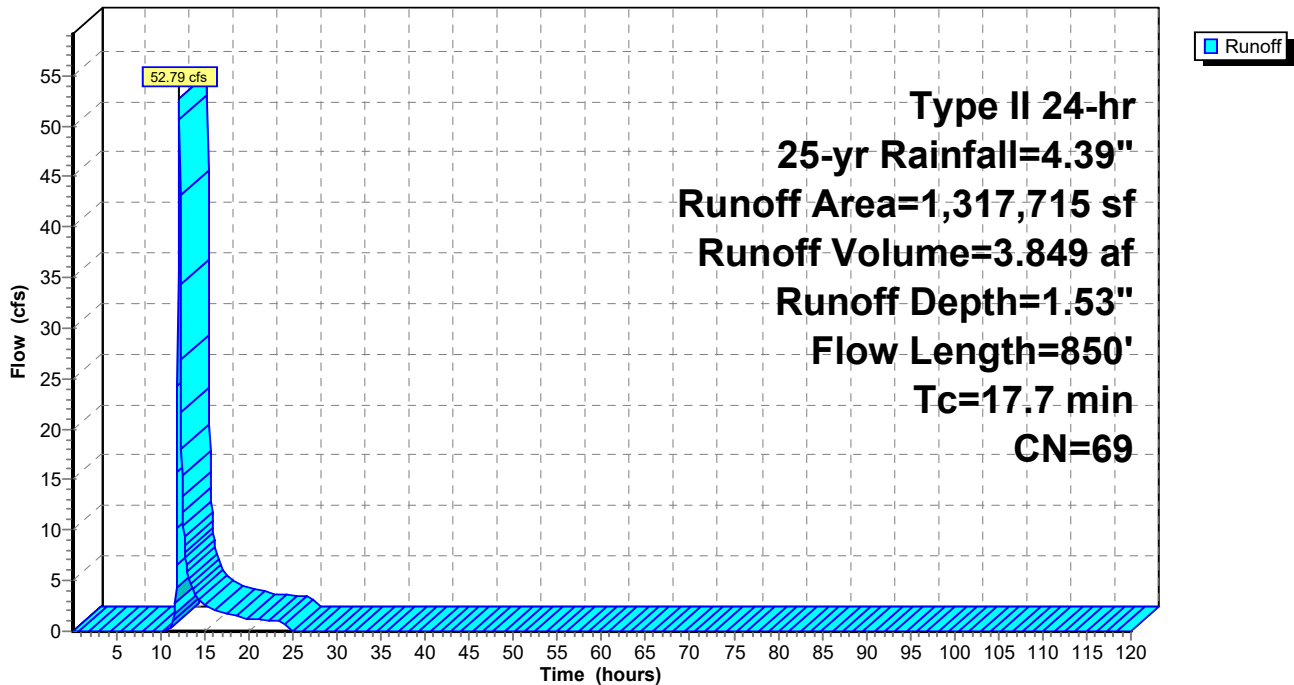

IGN Padua Ridge Existing v4 w culvert

Type II 24-hr 25-yr Rainfall=4.39"

Prepared by JMT

Printed 1/31/2022

HydroCAD® 10.00-20 s/n 02102 © 2017 HydroCAD Software Solutions LLC

Page 62

Hydrograph for Subcatchment 8: Downslope Area

Time (hours)	Precip. (inches)	Excess (inches)	Runoff (cfs)
0.05	0.00	0.00	0.00
2.55	0.13	0.00	0.00
5.05	0.28	0.00	0.00
7.55	0.48	0.00	0.00
10.05	0.80	0.00	0.00
12.55	3.25	0.81	11.80
15.05	3.75	1.11	2.63
17.55	4.01	1.27	1.72
20.05	4.18	1.39	1.21
22.55	4.32	1.48	1.07
25.05	4.39	1.53	0.00
27.55	4.39	1.53	0.00
30.05	4.39	1.53	0.00
32.55	4.39	1.53	0.00
35.05	4.39	1.53	0.00
37.55	4.39	1.53	0.00
40.05	4.39	1.53	0.00
42.55	4.39	1.53	0.00
45.05	4.39	1.53	0.00
47.55	4.39	1.53	0.00
50.05	4.39	1.53	0.00
52.55	4.39	1.53	0.00
55.05	4.39	1.53	0.00
57.55	4.39	1.53	0.00
60.05	4.39	1.53	0.00
62.55	4.39	1.53	0.00
65.05	4.39	1.53	0.00
67.55	4.39	1.53	0.00
70.05	4.39	1.53	0.00
72.55	4.39	1.53	0.00
75.05	4.39	1.53	0.00
77.55	4.39	1.53	0.00
80.05	4.39	1.53	0.00
82.55	4.39	1.53	0.00
85.05	4.39	1.53	0.00
87.55	4.39	1.53	0.00
90.05	4.39	1.53	0.00
92.55	4.39	1.53	0.00
95.05	4.39	1.53	0.00
97.55	4.39	1.53	0.00
100.05	4.39	1.53	0.00
102.55	4.39	1.53	0.00
105.05	4.39	1.53	0.00
107.55	4.39	1.53	0.00
110.05	4.39	1.53	0.00
112.55	4.39	1.53	0.00
115.05	4.39	1.53	0.00
117.55	4.39	1.53	0.00

Summary for Reach R1: Drainage Easement

Inflow Area = 48.669 ac, 1.19% Impervious, Inflow Depth = 1.78" for 25-yr event
Inflow = 54.21 cfs @ 12.11 hrs, Volume= 7.228 af
Outflow = 48.39 cfs @ 12.27 hrs, Volume= 7.228 af, Atten= 11%, Lag= 9.3 min

Routing by Stor-Ind+Trans method, Time Span= 0.05-120.00 hrs, dt= 0.05 hrs
Max. Velocity= 6.60 fps, Min. Travel Time= 5.3 min
Avg. Velocity = 1.33 fps, Avg. Travel Time= 26.4 min

Peak Storage= 15,523 cf @ 12.18 hrs
Average Depth at Peak Storage= 2.17'
Bank-Full Depth= 3.00' Flow Area= 12.0 sf, Capacity= 93.64 cfs

6.00' x 3.00' deep Parabolic Channel, n= 0.030 Earth, grassed & winding
Length= 2,109.0' Slope= 0.0166 '/'
Inlet Invert= 780.00', Outlet Invert= 745.00'

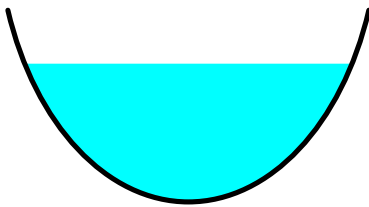

Reach R1: Drainage Easement

Hydrograph

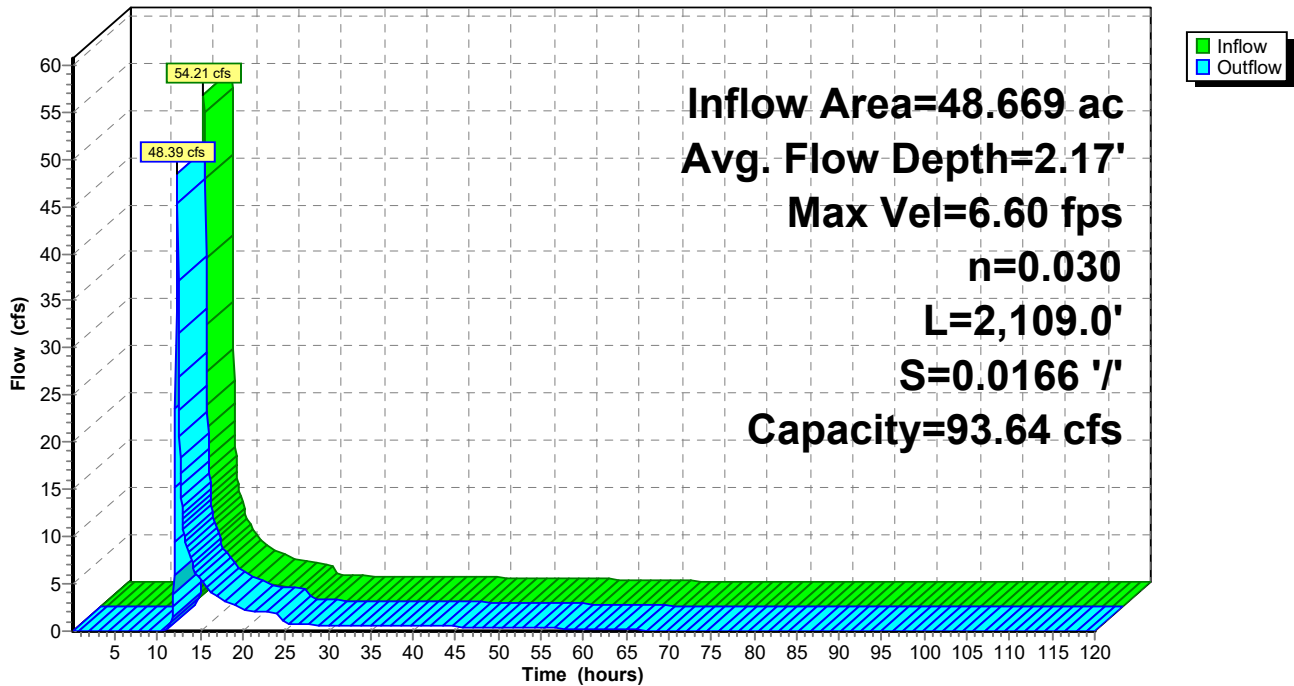

Reach R1: Drainage Easement

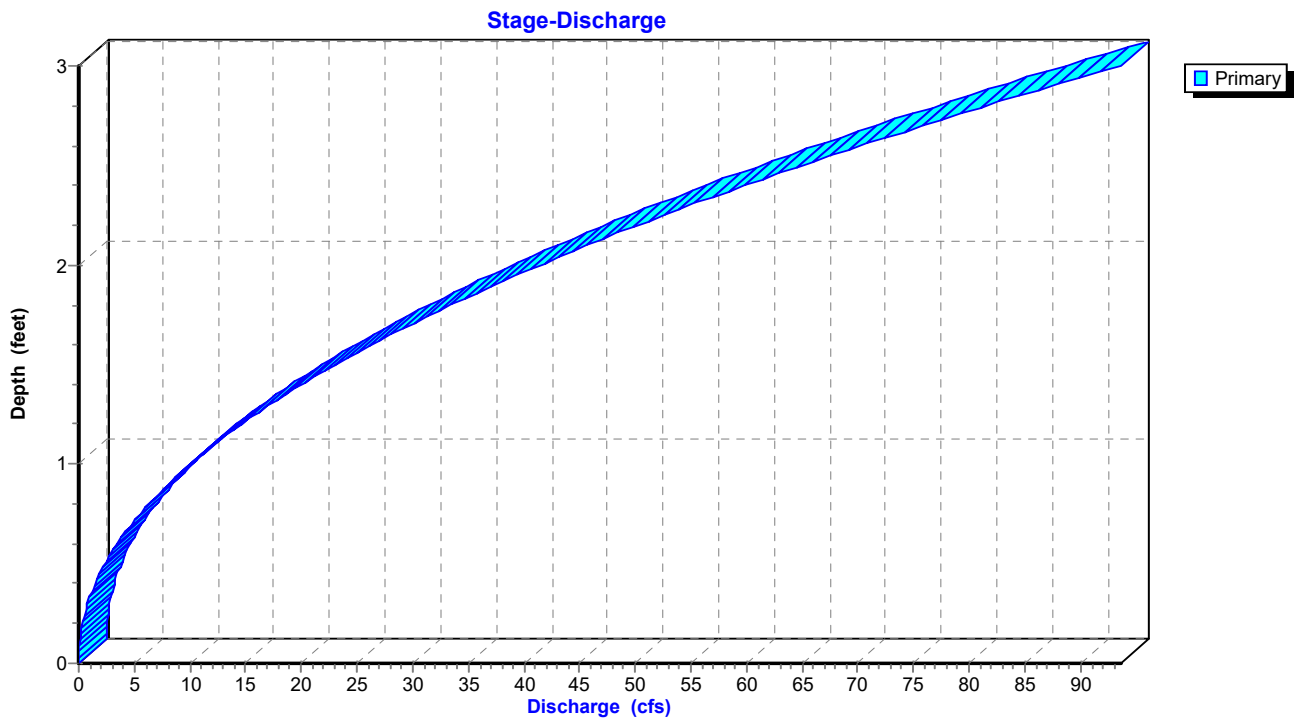

Reach R1: Drainage Easement

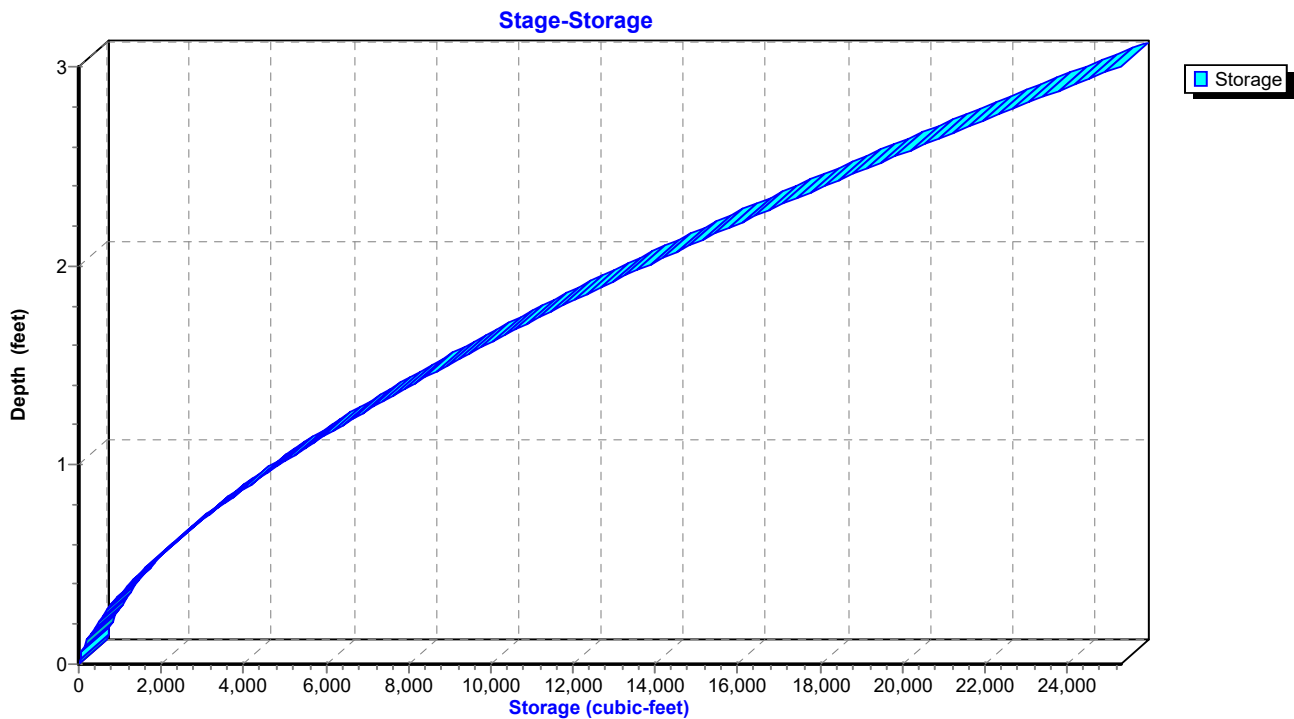

Hydrograph for Reach R1: Drainage Easement

Time (hours)	Inflow (cfs)	Storage (cubic-feet)	Elevation (feet)	Outflow (cfs)
0.05	0.00	0	780.00	0.00
2.55	0.00	0	780.00	0.00
5.05	0.00	0	780.00	0.00
7.55	0.00	0	780.00	0.00
10.05	0.03	29	780.03	0.00
12.55	15.56	7,725	781.36	23.37
15.05	5.10	3,050	780.73	5.33
17.55	3.23	2,189	780.59	3.33
20.05	2.29	1,721	780.50	2.38
22.55	1.95	1,518	780.46	1.98
25.05	0.69	743	780.29	0.73
27.55	0.66	704	780.28	0.66
30.05	0.63	685	780.27	0.64
32.55	0.61	663	780.26	0.61
35.05	0.58	641	780.26	0.58
37.55	0.55	618	780.25	0.55
40.05	0.52	595	780.25	0.52
42.55	0.49	569	780.24	0.49
45.05	0.45	541	780.23	0.46
47.55	0.42	511	780.22	0.42
50.05	0.38	480	780.21	0.39
52.55	0.34	446	780.20	0.35
55.05	0.30	409	780.19	0.31
57.55	0.26	370	780.18	0.27
60.05	0.22	325	780.16	0.22
62.55	0.17	279	780.15	0.18
65.05	0.12	224	780.13	0.13
67.55	0.08	163	780.10	0.08
70.05	0.05	114	780.08	0.05
72.55	0.03	81	780.06	0.03
75.05	0.02	58	780.05	0.02
77.55	0.01	43	780.04	0.01
80.05	0.01	38	780.04	0.01
82.55	0.01	35	780.04	0.01
85.05	0.01	31	780.03	0.01
87.55	0.01	29	780.03	0.01
90.05	0.01	27	780.03	0.01
92.55	0.01	24	780.03	0.01
95.05	0.00	21	780.03	0.00
97.55	0.00	18	780.02	0.00
100.05	0.00	16	780.02	0.00
102.55	0.00	14	780.02	0.00
105.05	0.00	12	780.01	0.00
107.55	0.00	10	780.01	0.00
110.05	0.00	9	780.01	0.00
112.55	0.00	8	780.01	0.00
115.05	0.00	7	780.01	0.00
117.55	0.00	6	780.01	0.00

IGN Padua Ridge Existing v4 w culvert

Type II 24-hr 25-yr Rainfall=4.39"

Prepared by JMT

Printed 1/31/2022

HydroCAD® 10.00-20 s/n 02102 © 2017 HydroCAD Software Solutions LLC

Page 66

Stage-Discharge for Reach R1: Drainage Easement

Elevation (feet)	Velocity (ft/sec)	Discharge (cfs)	Elevation (feet)	Velocity (ft/sec)	Discharge (cfs)	Elevation (feet)	Velocity (ft/sec)	Discharge (cfs)
780.00	0.00	0.00	781.04	4.43	10.86	782.08	6.48	44.86
780.02	0.31	0.00	781.06	4.48	11.29	782.10	6.51	45.74
780.04	0.56	0.01	781.08	4.53	11.74	782.12	6.54	46.62
780.06	0.74	0.03	781.10	4.58	12.19	782.14	6.57	47.52
780.08	0.89	0.05	781.12	4.62	12.66	782.16	6.60	48.42
780.10	1.03	0.08	781.14	4.67	13.12	782.18	6.64	49.33
780.12	1.16	0.11	781.16	4.72	13.61	782.20	6.67	50.25
780.14	1.29	0.16	781.18	4.76	14.09	782.22	6.70	51.17
780.16	1.40	0.21	781.20	4.81	14.59	782.24	6.73	52.11
780.18	1.51	0.27	781.22	4.85	15.10	782.26	6.76	53.05
780.20	1.62	0.34	781.24	4.89	15.61	782.28	6.79	54.00
780.22	1.72	0.41	781.26	4.94	16.13	782.30	6.82	54.96
780.24	1.82	0.49	781.28	4.98	16.66	782.32	6.85	55.93
780.26	1.91	0.59	781.30	5.03	17.20	782.34	6.88	56.90
780.28	2.01	0.69	781.32	5.07	17.75	782.36	6.91	57.88
780.30	2.10	0.79	781.34	5.11	18.31	782.38	6.94	58.88
780.32	2.18	0.91	781.36	5.15	18.88	782.40	6.97	59.87
780.34	2.27	1.04	781.38	5.19	19.45	782.42	7.00	60.88
780.36	2.35	1.17	781.40	5.24	20.03	782.44	7.03	61.90
780.38	2.43	1.32	781.42	5.28	20.62	782.46	7.06	62.92
780.40	2.51	1.47	781.44	5.32	21.22	782.48	7.09	63.96
780.42	2.58	1.62	781.46	5.36	21.83	782.50	7.12	65.00
780.44	2.66	1.79	781.48	5.40	22.45	782.52	7.15	66.04
780.46	2.73	1.97	781.50	5.44	23.07	782.54	7.18	67.10
780.48	2.80	2.15	781.52	5.48	23.71	782.56	7.21	68.17
780.50	2.87	2.35	781.54	5.52	24.35	782.58	7.23	69.24
780.52	2.94	2.55	781.56	5.55	25.00	782.60	7.26	70.32
780.54	3.01	2.76	781.58	5.59	25.66	782.62	7.29	71.41
780.56	3.08	2.98	781.60	5.63	26.32	782.64	7.32	72.51
780.58	3.15	3.21	781.62	5.67	27.00	782.66	7.35	73.62
780.60	3.21	3.45	781.64	5.71	27.68	782.68	7.38	74.73
780.62	3.27	3.69	781.66	5.74	28.38	782.70	7.40	75.85
780.64	3.34	3.95	781.68	5.78	29.08	782.72	7.43	76.98
780.66	3.40	4.21	781.70	5.82	29.79	782.74	7.46	78.12
780.68	3.46	4.48	781.72	5.86	30.51	782.76	7.49	79.26
780.70	3.52	4.76	781.74	5.89	31.23	782.78	7.51	80.42
780.72	3.58	5.05	781.76	5.93	31.97	782.80	7.54	81.58
780.74	3.64	5.35	781.78	5.96	32.71	782.82	7.57	82.75
780.76	3.70	5.66	781.80	6.00	33.46	782.84	7.59	83.93
780.78	3.75	5.97	781.82	6.03	34.22	782.86	7.62	85.12
780.80	3.81	6.30	781.84	6.07	34.99	782.88	7.65	86.31
780.82	3.86	6.63	781.86	6.11	35.77	782.90	7.67	87.51
780.84	3.92	6.97	781.88	6.14	36.55	782.92	7.70	88.72
780.86	3.97	7.32	781.90	6.17	37.35	782.94	7.73	89.94
780.88	4.03	7.68	781.92	6.21	38.15	782.96	7.75	91.17
780.90	4.08	8.04	781.94	6.24	38.96	782.98	7.78	92.40
780.92	4.13	8.42	781.96	6.28	39.78	783.00	7.80	93.64
780.94	4.18	8.81	781.98	6.31	40.60			
780.96	4.23	9.20	782.00	6.34	41.44			
780.98	4.28	9.60	782.02	6.38	42.28			
781.00	4.33	10.01	782.04	6.41	43.13			
781.02	4.38	10.43	782.06	6.44	43.99			

Stage-Area-Storage for Reach R1: Drainage Easement

Elevation (feet)	End-Area (sq-ft)	Storage (cubic-feet)	Elevation (feet)	End-Area (sq-ft)	Storage (cubic-feet)
780.00	0.0	0	782.60	9.7	20,419
780.05	0.0	56	782.65	10.0	21,011
780.10	0.1	155	782.70	10.2	21,608
780.15	0.1	283	782.75	10.5	22,212
780.20	0.2	436	782.80	10.8	22,820
780.25	0.3	610	782.85	11.1	23,434
780.30	0.4	800	782.90	11.4	24,053
780.35	0.5	1,009	782.95	11.7	24,678
780.40	0.6	1,233	783.00	12.0	25,308
780.45	0.7	1,470			
780.50	0.8	1,723			
780.55	0.9	1,987			
780.60	1.1	2,264			
780.65	1.2	2,553			
780.70	1.4	2,853			
780.75	1.5	3,164			
780.80	1.7	3,485			
780.85	1.8	3,817			
780.90	2.0	4,159			
780.95	2.1	4,510			
781.00	2.3	4,871			
781.05	2.5	5,240			
781.10	2.7	5,619			
781.15	2.8	6,007			
781.20	3.0	6,402			
781.25	3.2	6,807			
781.30	3.4	7,220			
781.35	3.6	7,640			
781.40	3.8	8,068			
781.45	4.0	8,504			
781.50	4.2	8,948			
781.55	4.5	9,399			
781.60	4.7	9,858			
781.65	4.9	10,323			
781.70	5.1	10,796			
781.75	5.3	11,276			
781.80	5.6	11,762			
781.85	5.8	12,256			
781.90	6.0	12,756			
781.95	6.3	13,263			
782.00	6.5	13,776			
782.05	6.8	14,296			
782.10	7.0	14,822			
782.15	7.3	15,355			
782.20	7.5	15,893			
782.25	7.8	16,438			
782.30	8.1	16,989			
782.35	8.3	17,546			
782.40	8.6	18,109			
782.45	8.9	18,678			
782.50	9.1	19,253			
782.55	9.4	19,833			

Summary for Pond P1: Infiltration Area

Inflow Area = 6.720 ac, 0.00% Impervious, Inflow Depth = 0.64" for 25-yr event
 Inflow = 4.30 cfs @ 12.09 hrs, Volume= 0.361 af
 Outflow = 0.14 cfs @ 23.99 hrs, Volume= 0.361 af, Atten= 97%, Lag= 714.5 min
 Discarded = 0.14 cfs @ 23.99 hrs, Volume= 0.361 af

Routing by Stor-Ind method, Time Span= 0.05-120.00 hrs, dt= 0.05 hrs
 Peak Elev= 855.85' @ 23.99 hrs Surf.Area= 11,336 sf Storage= 9,623 cf

Plug-Flow detention time= 754.9 min calculated for 0.361 af (100% of inflow)
 Center-of-Mass det. time= 755.1 min (1,671.1 - 916.0)

Volume	Invert	Avail.Storage	Storage Description
#1	855.00'	22,672 cf	Custom Stage Data (Prismatic) Listed below (Recalc)

Elevation (feet)	Surf.Area (sq-ft)	Inc.Store (cubic-feet)	Cum.Store (cubic-feet)
855.00	11,336	0	0
856.00	11,336	11,336	11,336
857.00	11,336	11,336	22,672

Device	Routing	Invert	Outlet Devices
#1	Discarded	855.00'	0.500 in/hr Exfiltration over Surface area Conductivity to Groundwater Elevation = 840.00'

Discarded OutFlow Max=0.14 cfs @ 23.99 hrs HW=855.85' (Free Discharge)

↑**1=Exfiltration** (Controls 0.14 cfs)

Pond P1: Infiltration Area

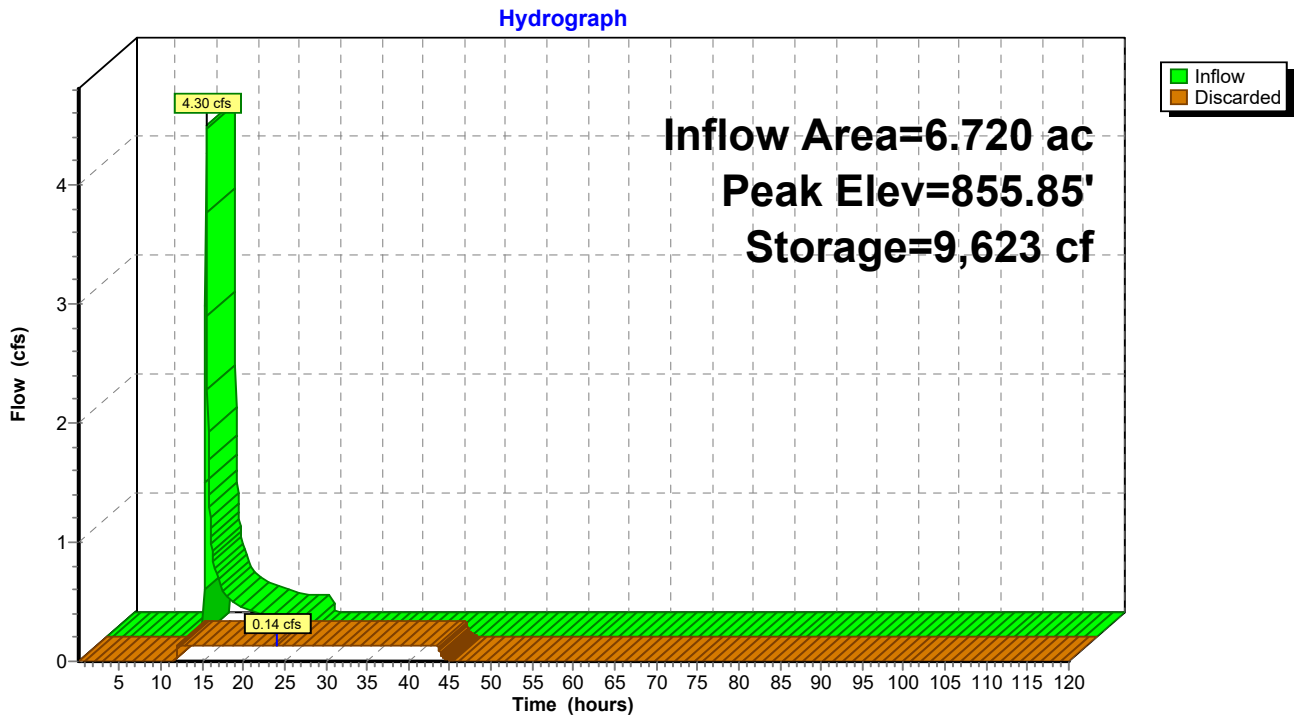

Pond P1: Infiltration Area

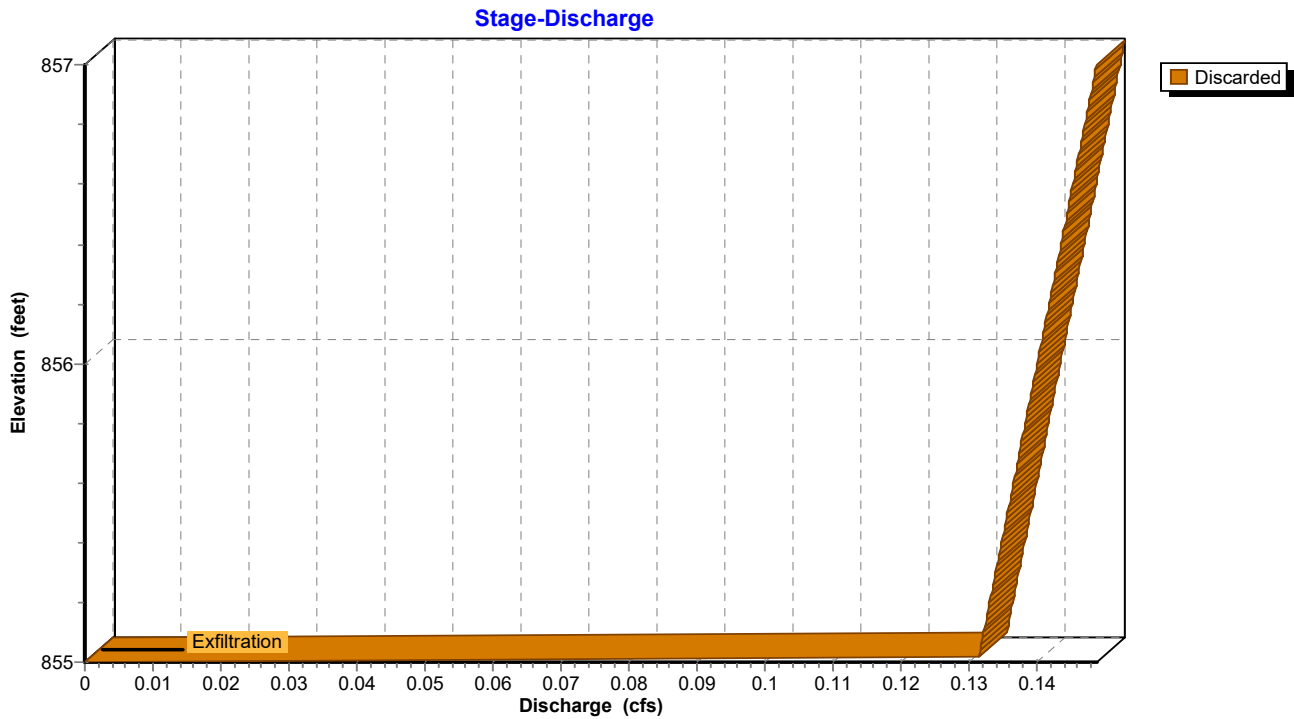

Pond P1: Infiltration Area

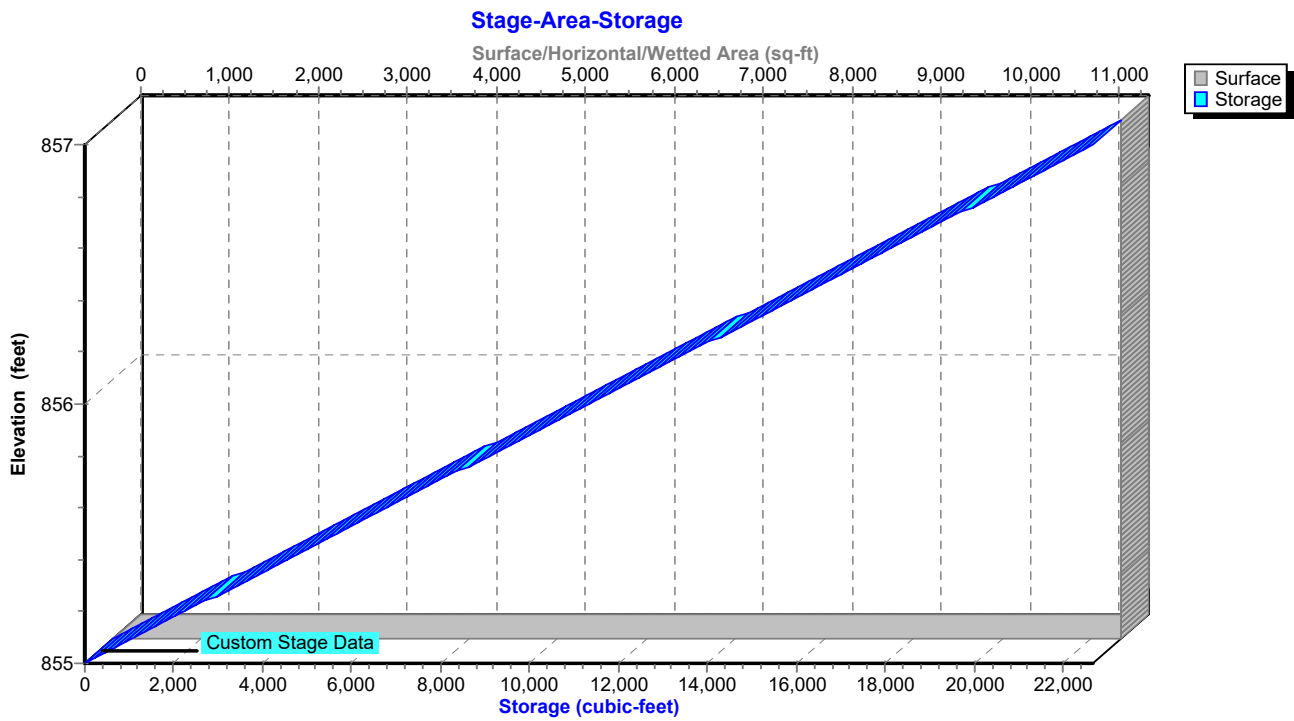

Hydrograph for Pond P1: Infiltration Area

Time (hours)	Inflow (cfs)	Storage (cubic-feet)	Elevation (feet)	Discarded (cfs)
0.05	0.00	0	855.00	0.00
2.55	0.00	0	855.00	0.00
5.05	0.00	0	855.00	0.00
7.55	0.00	0	855.00	0.00
10.05	0.00	0	855.00	0.00
12.55	1.00	4,832	855.43	0.13
15.05	0.32	7,938	855.70	0.14
17.55	0.22	9,025	855.80	0.14
20.05	0.16	9,497	855.84	0.14
22.55	0.15	9,604	855.85	0.14
25.05	0.00	9,201	855.81	0.14
27.55	0.00	7,961	855.70	0.14
30.05	0.00	6,729	855.59	0.14
32.55	0.00	5,505	855.49	0.14
35.05	0.00	4,291	855.38	0.13
37.55	0.00	3,084	855.27	0.13
40.05	0.00	1,886	855.17	0.13
42.55	0.00	696	855.06	0.13
45.05	0.00	10	855.00	0.01
47.55	0.00	0	855.00	0.00
50.05	0.00	0	855.00	0.00
52.55	0.00	0	855.00	0.00
55.05	0.00	0	855.00	0.00
57.55	0.00	0	855.00	0.00
60.05	0.00	0	855.00	0.00
62.55	0.00	0	855.00	0.00
65.05	0.00	0	855.00	0.00
67.55	0.00	0	855.00	0.00
70.05	0.00	0	855.00	0.00
72.55	0.00	0	855.00	0.00
75.05	0.00	0	855.00	0.00
77.55	0.00	0	855.00	0.00
80.05	0.00	0	855.00	0.00
82.55	0.00	0	855.00	0.00
85.05	0.00	0	855.00	0.00
87.55	0.00	0	855.00	0.00
90.05	0.00	0	855.00	0.00
92.55	0.00	0	855.00	0.00
95.05	0.00	0	855.00	0.00
97.55	0.00	0	855.00	0.00
100.05	0.00	0	855.00	0.00
102.55	0.00	0	855.00	0.00
105.05	0.00	0	855.00	0.00
107.55	0.00	0	855.00	0.00
110.05	0.00	0	855.00	0.00
112.55	0.00	0	855.00	0.00
115.05	0.00	0	855.00	0.00
117.55	0.00	0	855.00	0.00

Stage-Discharge for Pond P1: Infiltration Area

Elevation (feet)	Discarded (cfs)	Elevation (feet)	Discarded (cfs)	Elevation (feet)	Discarded (cfs)	Elevation (feet)	Discarded (cfs)
855.00	0.00	855.52	0.14	856.04	0.14	856.56	0.14
855.01	0.13	855.53	0.14	856.05	0.14	856.57	0.14
855.02	0.13	855.54	0.14	856.06	0.14	856.58	0.15
855.03	0.13	855.55	0.14	856.07	0.14	856.59	0.15
855.04	0.13	855.56	0.14	856.08	0.14	856.60	0.15
855.05	0.13	855.57	0.14	856.09	0.14	856.61	0.15
855.06	0.13	855.58	0.14	856.10	0.14	856.62	0.15
855.07	0.13	855.59	0.14	856.11	0.14	856.63	0.15
855.08	0.13	855.60	0.14	856.12	0.14	856.64	0.15
855.09	0.13	855.61	0.14	856.13	0.14	856.65	0.15
855.10	0.13	855.62	0.14	856.14	0.14	856.66	0.15
855.11	0.13	855.63	0.14	856.15	0.14	856.67	0.15
855.12	0.13	855.64	0.14	856.16	0.14	856.68	0.15
855.13	0.13	855.65	0.14	856.17	0.14	856.69	0.15
855.14	0.13	855.66	0.14	856.18	0.14	856.70	0.15
855.15	0.13	855.67	0.14	856.19	0.14	856.71	0.15
855.16	0.13	855.68	0.14	856.20	0.14	856.72	0.15
855.17	0.13	855.69	0.14	856.21	0.14	856.73	0.15
855.18	0.13	855.70	0.14	856.22	0.14	856.74	0.15
855.19	0.13	855.71	0.14	856.23	0.14	856.75	0.15
855.20	0.13	855.72	0.14	856.24	0.14	856.76	0.15
855.21	0.13	855.73	0.14	856.25	0.14	856.77	0.15
855.22	0.13	855.74	0.14	856.26	0.14	856.78	0.15
855.23	0.13	855.75	0.14	856.27	0.14	856.79	0.15
855.24	0.13	855.76	0.14	856.28	0.14	856.80	0.15
855.25	0.13	855.77	0.14	856.29	0.14	856.81	0.15
855.26	0.13	855.78	0.14	856.30	0.14	856.82	0.15
855.27	0.13	855.79	0.14	856.31	0.14	856.83	0.15
855.28	0.13	855.80	0.14	856.32	0.14	856.84	0.15
855.29	0.13	855.81	0.14	856.33	0.14	856.85	0.15
855.30	0.13	855.82	0.14	856.34	0.14	856.86	0.15
855.31	0.13	855.83	0.14	856.35	0.14	856.87	0.15
855.32	0.13	855.84	0.14	856.36	0.14	856.88	0.15
855.33	0.13	855.85	0.14	856.37	0.14	856.89	0.15
855.34	0.13	855.86	0.14	856.38	0.14	856.90	0.15
855.35	0.13	855.87	0.14	856.39	0.14	856.91	0.15
855.36	0.13	855.88	0.14	856.40	0.14	856.92	0.15
855.37	0.13	855.89	0.14	856.41	0.14	856.93	0.15
855.38	0.13	855.90	0.14	856.42	0.14	856.94	0.15
855.39	0.13	855.91	0.14	856.43	0.14	856.95	0.15
855.40	0.13	855.92	0.14	856.44	0.14	856.96	0.15
855.41	0.13	855.93	0.14	856.45	0.14	856.97	0.15
855.42	0.13	855.94	0.14	856.46	0.14	856.98	0.15
855.43	0.13	855.95	0.14	856.47	0.14	856.99	0.15
855.44	0.14	855.96	0.14	856.48	0.14	857.00	0.15
855.45	0.14	855.97	0.14	856.49	0.14		
855.46	0.14	855.98	0.14	856.50	0.14		
855.47	0.14	855.99	0.14	856.51	0.14		
855.48	0.14	856.00	0.14	856.52	0.14		
855.49	0.14	856.01	0.14	856.53	0.14		
855.50	0.14	856.02	0.14	856.54	0.14		
855.51	0.14	856.03	0.14	856.55	0.14		

Stage-Area-Storage for Pond P1: Infiltration Area

Elevation (feet)	Surface (sq-ft)	Storage (cubic-feet)	Elevation (feet)	Surface (sq-ft)	Storage (cubic-feet)
855.00	11,336	0	856.04	11,336	11,789
855.02	11,336	227	856.06	11,336	12,016
855.04	11,336	453	856.08	11,336	12,243
855.06	11,336	680	856.10	11,336	12,470
855.08	11,336	907	856.12	11,336	12,696
855.10	11,336	1,134	856.14	11,336	12,923
855.12	11,336	1,360	856.16	11,336	13,150
855.14	11,336	1,587	856.18	11,336	13,376
855.16	11,336	1,814	856.20	11,336	13,603
855.18	11,336	2,040	856.22	11,336	13,830
855.20	11,336	2,267	856.24	11,336	14,057
855.22	11,336	2,494	856.26	11,336	14,283
855.24	11,336	2,721	856.28	11,336	14,510
855.26	11,336	2,947	856.30	11,336	14,737
855.28	11,336	3,174	856.32	11,336	14,964
855.30	11,336	3,401	856.34	11,336	15,190
855.32	11,336	3,628	856.36	11,336	15,417
855.34	11,336	3,854	856.38	11,336	15,644
855.36	11,336	4,081	856.40	11,336	15,870
855.38	11,336	4,308	856.42	11,336	16,097
855.40	11,336	4,534	856.44	11,336	16,324
855.42	11,336	4,761	856.46	11,336	16,551
855.44	11,336	4,988	856.48	11,336	16,777
855.46	11,336	5,215	856.50	11,336	17,004
855.48	11,336	5,441	856.52	11,336	17,231
855.50	11,336	5,668	856.54	11,336	17,457
855.52	11,336	5,895	856.56	11,336	17,684
855.54	11,336	6,121	856.58	11,336	17,911
855.56	11,336	6,348	856.60	11,336	18,138
855.58	11,336	6,575	856.62	11,336	18,364
855.60	11,336	6,802	856.64	11,336	18,591
855.62	11,336	7,028	856.66	11,336	18,818
855.64	11,336	7,255	856.68	11,336	19,044
855.66	11,336	7,482	856.70	11,336	19,271
855.68	11,336	7,708	856.72	11,336	19,498
855.70	11,336	7,935	856.74	11,336	19,725
855.72	11,336	8,162	856.76	11,336	19,951
855.74	11,336	8,389	856.78	11,336	20,178
855.76	11,336	8,615	856.80	11,336	20,405
855.78	11,336	8,842	856.82	11,336	20,632
855.80	11,336	9,069	856.84	11,336	20,858
855.82	11,336	9,296	856.86	11,336	21,085
855.84	11,336	9,522	856.88	11,336	21,312
855.86	11,336	9,749	856.90	11,336	21,538
855.88	11,336	9,976	856.92	11,336	21,765
855.90	11,336	10,202	856.94	11,336	21,992
855.92	11,336	10,429	856.96	11,336	22,219
855.94	11,336	10,656	856.98	11,336	22,445
855.96	11,336	10,883	857.00	11,336	22,672
855.98	11,336	11,109			
856.00	11,336	11,336			
856.02	11,336	11,563			

IGN Padua Ridge Existing v4 w culvert

Type II 24-hr 25-yr Rainfall=4.39"

Prepared by JMT

Printed 1/31/2022

HydroCAD® 10.00-20 s/n 02102 © 2017 HydroCAD Software Solutions LLC

Page 74

Summary for Pond P3: Infiltration Area

Inflow Area = 13.661 ac, 0.00% Impervious, Inflow Depth = 0.02" for 25-yr event
 Inflow = 0.05 cfs @ 23.95 hrs, Volume= 0.027 af
 Outflow = 0.05 cfs @ 24.00 hrs, Volume= 0.027 af, Atten= 1%, Lag= 3.0 min
 Discarded = 0.05 cfs @ 24.00 hrs, Volume= 0.027 af

Routing by Stor-Ind method, Time Span= 0.05-120.00 hrs, dt= 0.05 hrs
 Peak Elev= 862.01' @ 24.00 hrs Surf.Area= 10,679 sf Storage= 78 cf

Plug-Flow detention time= 28.7 min calculated for 0.027 af (100% of inflow)
 Center-of-Mass det. time= 28.8 min (1,235.8 - 1,207.0)

Volume	Invert	Avail.Storage	Storage Description
#1	862.00'	21,358 cf	Custom Stage Data (Prismatic) Listed below (Recalc)
Elevation (feet)	Surf.Area (sq-ft)	Inc.Store (cubic-feet)	Cum.Store (cubic-feet)
862.00	10,679	0	0
863.00	10,679	10,679	10,679
864.00	10,679	10,679	21,358

Device	Routing	Invert	Outlet Devices
#1	Discarded	862.00'	0.500 in/hr Exfiltration over Surface area Conductivity to Groundwater Elevation = 840.00'

Discarded OutFlow Max=0.12 cfs @ 24.00 hrs HW=862.01' (Free Discharge)

↑**1=Exfiltration** (Controls 0.12 cfs)

Pond P3: Infiltration Area

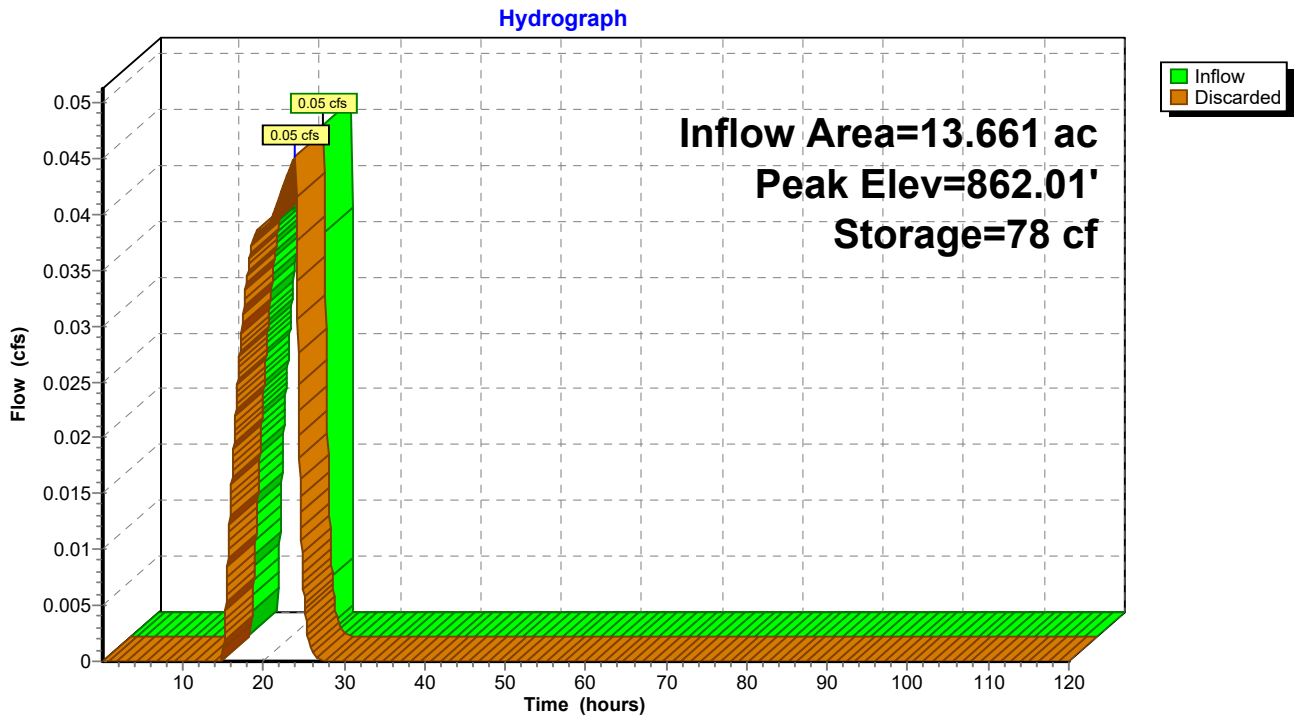

Pond P3: Infiltration Area

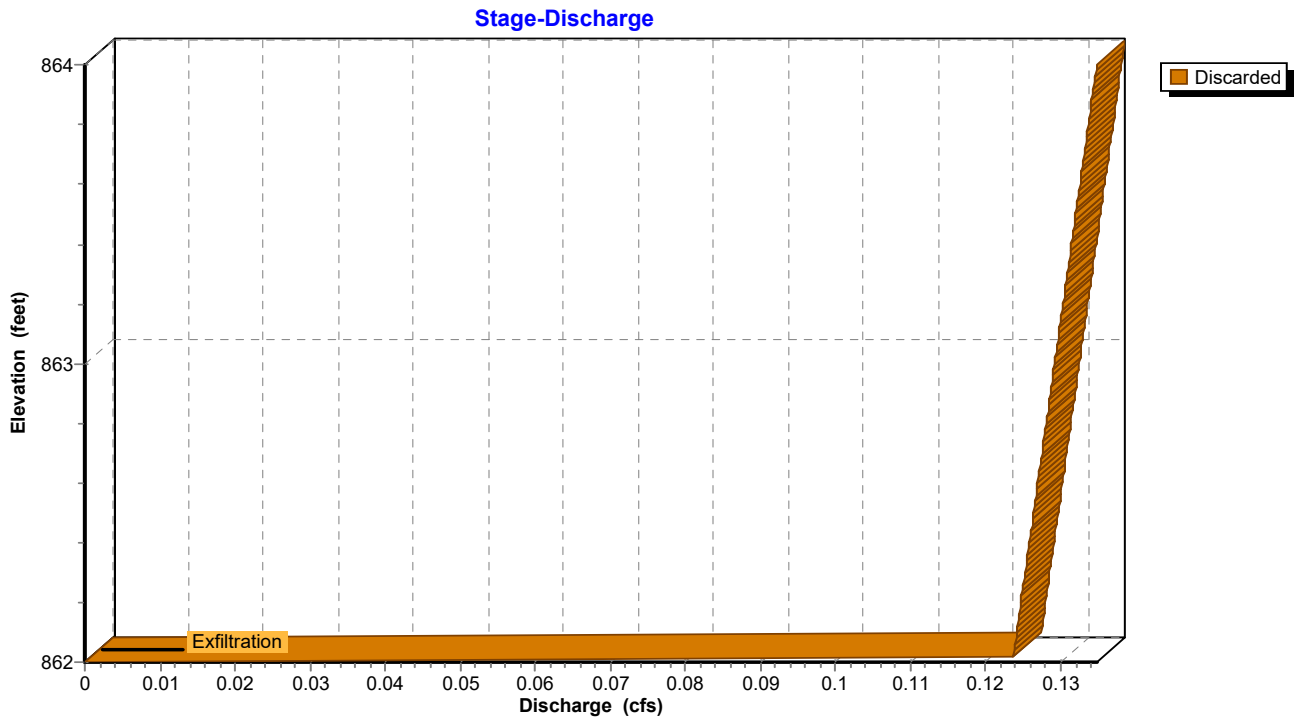

Pond P3: Infiltration Area

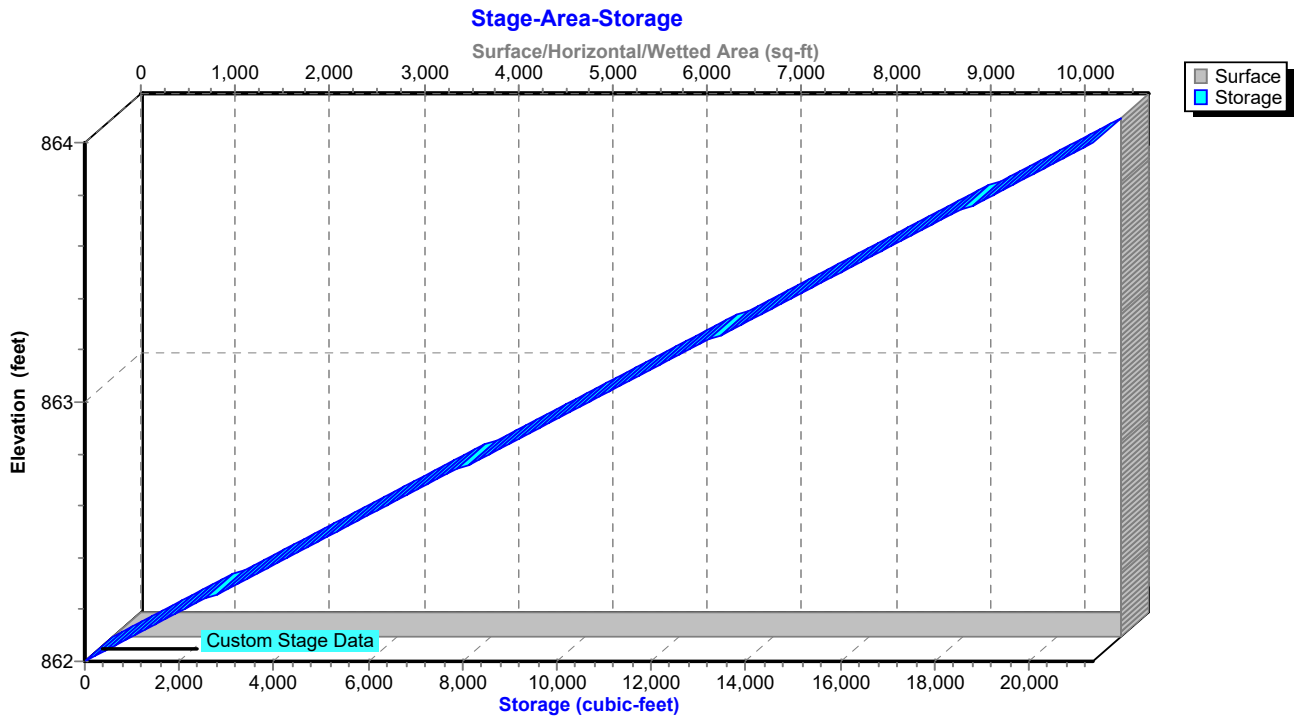

IGN Padua Ridge Existing v4 w culvert

Type II 24-hr 25-yr Rainfall=4.39"

Prepared by JMT

Printed 1/31/2022

HydroCAD® 10.00-20 s/n 02102 © 2017 HydroCAD Software Solutions LLC

Page 77

Hydrograph for Pond P3: Infiltration Area

Time (hours)	Inflow (cfs)	Storage (cubic-feet)	Elevation (feet)	Discarded (cfs)
0.05	0.00	0	862.00	0.00
2.55	0.00	0	862.00	0.00
5.05	0.00	0	862.00	0.00
7.55	0.00	0	862.00	0.00
10.05	0.00	0	862.00	0.00
12.55	0.00	0	862.00	0.00
15.05	0.01	2	862.00	0.00
17.55	0.04	55	862.01	0.03
20.05	0.04	67	862.01	0.04
22.55	0.04	74	862.01	0.04
25.05	0.00	10	862.00	0.01
27.55	0.00	0	862.00	0.00
30.05	0.00	0	862.00	0.00
32.55	0.00	0	862.00	0.00
35.05	0.00	0	862.00	0.00
37.55	0.00	0	862.00	0.00
40.05	0.00	0	862.00	0.00
42.55	0.00	0	862.00	0.00
45.05	0.00	0	862.00	0.00
47.55	0.00	0	862.00	0.00
50.05	0.00	0	862.00	0.00
52.55	0.00	0	862.00	0.00
55.05	0.00	0	862.00	0.00
57.55	0.00	0	862.00	0.00
60.05	0.00	0	862.00	0.00
62.55	0.00	0	862.00	0.00
65.05	0.00	0	862.00	0.00
67.55	0.00	0	862.00	0.00
70.05	0.00	0	862.00	0.00
72.55	0.00	0	862.00	0.00
75.05	0.00	0	862.00	0.00
77.55	0.00	0	862.00	0.00
80.05	0.00	0	862.00	0.00
82.55	0.00	0	862.00	0.00
85.05	0.00	0	862.00	0.00
87.55	0.00	0	862.00	0.00
90.05	0.00	0	862.00	0.00
92.55	0.00	0	862.00	0.00
95.05	0.00	0	862.00	0.00
97.55	0.00	0	862.00	0.00
100.05	0.00	0	862.00	0.00
102.55	0.00	0	862.00	0.00
105.05	0.00	0	862.00	0.00
107.55	0.00	0	862.00	0.00
110.05	0.00	0	862.00	0.00
112.55	0.00	0	862.00	0.00
115.05	0.00	0	862.00	0.00
117.55	0.00	0	862.00	0.00

Stage-Discharge for Pond P3: Infiltration Area

Elevation (feet)	Discarded (cfs)	Elevation (feet)	Discarded (cfs)	Elevation (feet)	Discarded (cfs)	Elevation (feet)	Discarded (cfs)
862.00	0.00	862.52	0.13	863.04	0.13	863.56	0.13
862.01	0.12	862.53	0.13	863.05	0.13	863.57	0.13
862.02	0.12	862.54	0.13	863.06	0.13	863.58	0.13
862.03	0.12	862.55	0.13	863.07	0.13	863.59	0.13
862.04	0.12	862.56	0.13	863.08	0.13	863.60	0.13
862.05	0.12	862.57	0.13	863.09	0.13	863.61	0.13
862.06	0.12	862.58	0.13	863.10	0.13	863.62	0.13
862.07	0.12	862.59	0.13	863.11	0.13	863.63	0.13
862.08	0.12	862.60	0.13	863.12	0.13	863.64	0.13
862.09	0.12	862.61	0.13	863.13	0.13	863.65	0.13
862.10	0.12	862.62	0.13	863.14	0.13	863.66	0.13
862.11	0.12	862.63	0.13	863.15	0.13	863.67	0.13
862.12	0.12	862.64	0.13	863.16	0.13	863.68	0.13
862.13	0.12	862.65	0.13	863.17	0.13	863.69	0.13
862.14	0.12	862.66	0.13	863.18	0.13	863.70	0.13
862.15	0.12	862.67	0.13	863.19	0.13	863.71	0.13
862.16	0.12	862.68	0.13	863.20	0.13	863.72	0.13
862.17	0.12	862.69	0.13	863.21	0.13	863.73	0.13
862.18	0.12	862.70	0.13	863.22	0.13	863.74	0.13
862.19	0.12	862.71	0.13	863.23	0.13	863.75	0.13
862.20	0.12	862.72	0.13	863.24	0.13	863.76	0.13
862.21	0.12	862.73	0.13	863.25	0.13	863.77	0.13
862.22	0.12	862.74	0.13	863.26	0.13	863.78	0.13
862.23	0.12	862.75	0.13	863.27	0.13	863.79	0.13
862.24	0.12	862.76	0.13	863.28	0.13	863.80	0.13
862.25	0.13	862.77	0.13	863.29	0.13	863.81	0.13
862.26	0.13	862.78	0.13	863.30	0.13	863.82	0.13
862.27	0.13	862.79	0.13	863.31	0.13	863.83	0.13
862.28	0.13	862.80	0.13	863.32	0.13	863.84	0.13
862.29	0.13	862.81	0.13	863.33	0.13	863.85	0.13
862.30	0.13	862.82	0.13	863.34	0.13	863.86	0.13
862.31	0.13	862.83	0.13	863.35	0.13	863.87	0.13
862.32	0.13	862.84	0.13	863.36	0.13	863.88	0.13
862.33	0.13	862.85	0.13	863.37	0.13	863.89	0.13
862.34	0.13	862.86	0.13	863.38	0.13	863.90	0.13
862.35	0.13	862.87	0.13	863.39	0.13	863.91	0.13
862.36	0.13	862.88	0.13	863.40	0.13	863.92	0.13
862.37	0.13	862.89	0.13	863.41	0.13	863.93	0.13
862.38	0.13	862.90	0.13	863.42	0.13	863.94	0.13
862.39	0.13	862.91	0.13	863.43	0.13	863.95	0.13
862.40	0.13	862.92	0.13	863.44	0.13	863.96	0.13
862.41	0.13	862.93	0.13	863.45	0.13	863.97	0.13
862.42	0.13	862.94	0.13	863.46	0.13	863.98	0.13
862.43	0.13	862.95	0.13	863.47	0.13	863.99	0.13
862.44	0.13	862.96	0.13	863.48	0.13	864.00	0.13
862.45	0.13	862.97	0.13	863.49	0.13		
862.46	0.13	862.98	0.13	863.50	0.13		
862.47	0.13	862.99	0.13	863.51	0.13		
862.48	0.13	863.00	0.13	863.52	0.13		
862.49	0.13	863.01	0.13	863.53	0.13		
862.50	0.13	863.02	0.13	863.54	0.13		
862.51	0.13	863.03	0.13	863.55	0.13		

Stage-Area-Storage for Pond P3: Infiltration Area

Elevation (feet)	Surface (sq-ft)	Storage (cubic-feet)	Elevation (feet)	Surface (sq-ft)	Storage (cubic-feet)
862.00	10,679	0	863.04	10,679	11,106
862.02	10,679	214	863.06	10,679	11,320
862.04	10,679	427	863.08	10,679	11,533
862.06	10,679	641	863.10	10,679	11,747
862.08	10,679	854	863.12	10,679	11,960
862.10	10,679	1,068	863.14	10,679	12,174
862.12	10,679	1,281	863.16	10,679	12,388
862.14	10,679	1,495	863.18	10,679	12,601
862.16	10,679	1,709	863.20	10,679	12,815
862.18	10,679	1,922	863.22	10,679	13,028
862.20	10,679	2,136	863.24	10,679	13,242
862.22	10,679	2,349	863.26	10,679	13,456
862.24	10,679	2,563	863.28	10,679	13,669
862.26	10,679	2,777	863.30	10,679	13,883
862.28	10,679	2,990	863.32	10,679	14,096
862.30	10,679	3,204	863.34	10,679	14,310
862.32	10,679	3,417	863.36	10,679	14,523
862.34	10,679	3,631	863.38	10,679	14,737
862.36	10,679	3,844	863.40	10,679	14,951
862.38	10,679	4,058	863.42	10,679	15,164
862.40	10,679	4,272	863.44	10,679	15,378
862.42	10,679	4,485	863.46	10,679	15,591
862.44	10,679	4,699	863.48	10,679	15,805
862.46	10,679	4,912	863.50	10,679	16,019
862.48	10,679	5,126	863.52	10,679	16,232
862.50	10,679	5,340	863.54	10,679	16,446
862.52	10,679	5,553	863.56	10,679	16,659
862.54	10,679	5,767	863.58	10,679	16,873
862.56	10,679	5,980	863.60	10,679	17,086
862.58	10,679	6,194	863.62	10,679	17,300
862.60	10,679	6,407	863.64	10,679	17,514
862.62	10,679	6,621	863.66	10,679	17,727
862.64	10,679	6,835	863.68	10,679	17,941
862.66	10,679	7,048	863.70	10,679	18,154
862.68	10,679	7,262	863.72	10,679	18,368
862.70	10,679	7,475	863.74	10,679	18,581
862.72	10,679	7,689	863.76	10,679	18,795
862.74	10,679	7,902	863.78	10,679	19,009
862.76	10,679	8,116	863.80	10,679	19,222
862.78	10,679	8,330	863.82	10,679	19,436
862.80	10,679	8,543	863.84	10,679	19,649
862.82	10,679	8,757	863.86	10,679	19,863
862.84	10,679	8,970	863.88	10,679	20,077
862.86	10,679	9,184	863.90	10,679	20,290
862.88	10,679	9,398	863.92	10,679	20,504
862.90	10,679	9,611	863.94	10,679	20,717
862.92	10,679	9,825	863.96	10,679	20,931
862.94	10,679	10,038	863.98	10,679	21,144
862.96	10,679	10,252	864.00	10,679	21,358
862.98	10,679	10,465			
863.00	10,679	10,679			
863.02	10,679	10,893			

IGN Padua Ridge Existing v4 w culvert

Type II 24-hr 25-yr Rainfall=4.39"

Prepared by JMT

Printed 1/31/2022

HydroCAD® 10.00-20 s/n 02102 © 2017 HydroCAD Software Solutions LLC

Page 80

Summary for Pond P4A: Mine Ponds

Inflow Area = 18.419 ac, 3.15% Impervious, Inflow Depth = 2.20" for 25-yr event
 Inflow = 78.58 cfs @ 11.93 hrs, Volume= 3.380 af
 Outflow = 78.42 cfs @ 11.93 hrs, Volume= 3.380 af, Atten= 0%, Lag= 0.1 min
 Primary = 78.42 cfs @ 11.93 hrs, Volume= 3.380 af

Routing by Stor-Ind method, Time Span= 0.05-120.00 hrs, dt= 0.05 hrs
 Starting Elev= 844.00' Surf.Area= 2,500 sf Storage= 2,114 cf
 Peak Elev= 844.32' @ 11.93 hrs Surf.Area= 2,500 sf Storage= 2,926 cf (812 cf above start)

Plug-Flow detention time= 12.6 min calculated for 3.332 af (99% of inflow)
 Center-of-Mass det. time= 0.4 min (827.2 - 826.8)

Volume	Invert	Avail.Storage	Storage Description
#1	843.00'	7,114 cf	Custom Stage Data (Conic) Listed below (Recalc)

Elevation (feet)	Surf.Area (sq-ft)	Inc.Store (cubic-feet)	Cum.Store (cubic-feet)	Wet.Area (sq-ft)
843.00	1,750	0	0	1,750
844.00	2,500	2,114	2,114	2,517
846.00	2,500	5,000	7,114	2,872

Device	Routing	Invert	Outlet Devices
#1	Primary	844.00'	130.0' long Sharp-Crested Rectangular Weir 0 End Contraction(s)

Primary OutFlow Max=74.42 cfs @ 11.93 hrs HW=844.31' (Free Discharge)

↑1=Sharp-Crested Rectangular Weir (Weir Controls 74.42 cfs @ 1.83 fps)

Pond P4A: Mine Ponds

Hydrograph

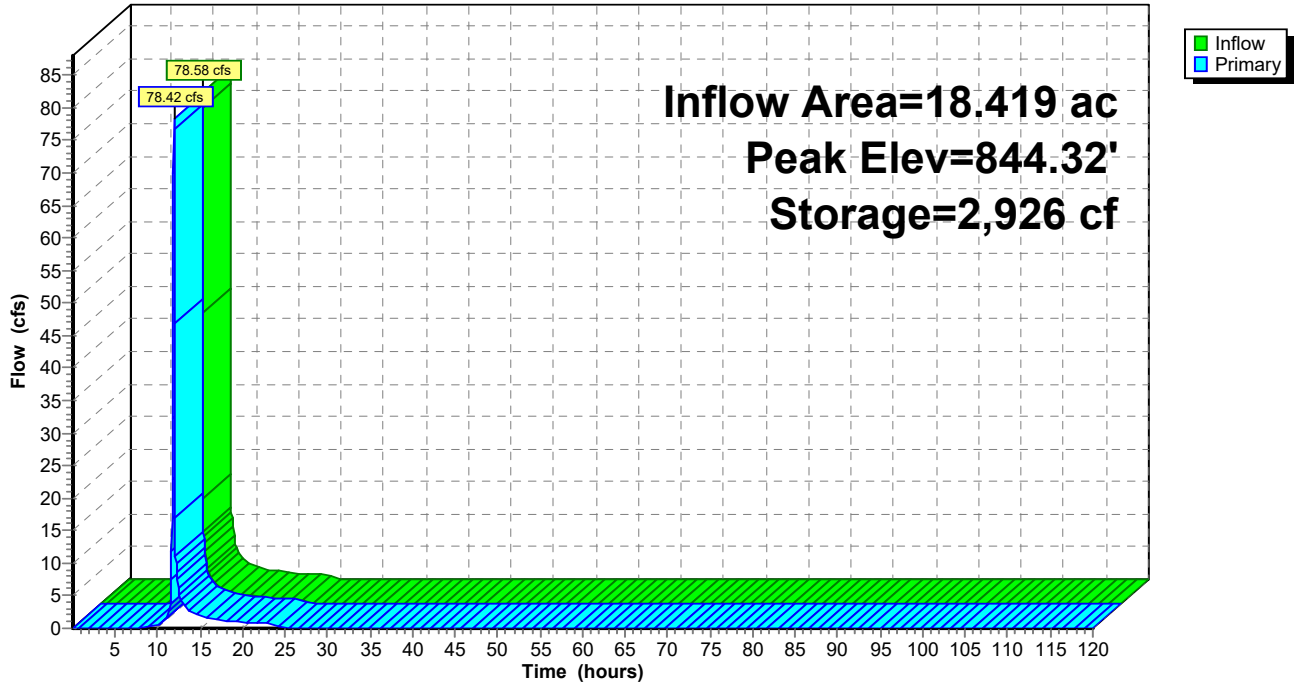

Pond P4A: Mine Ponds

Stage-Discharge

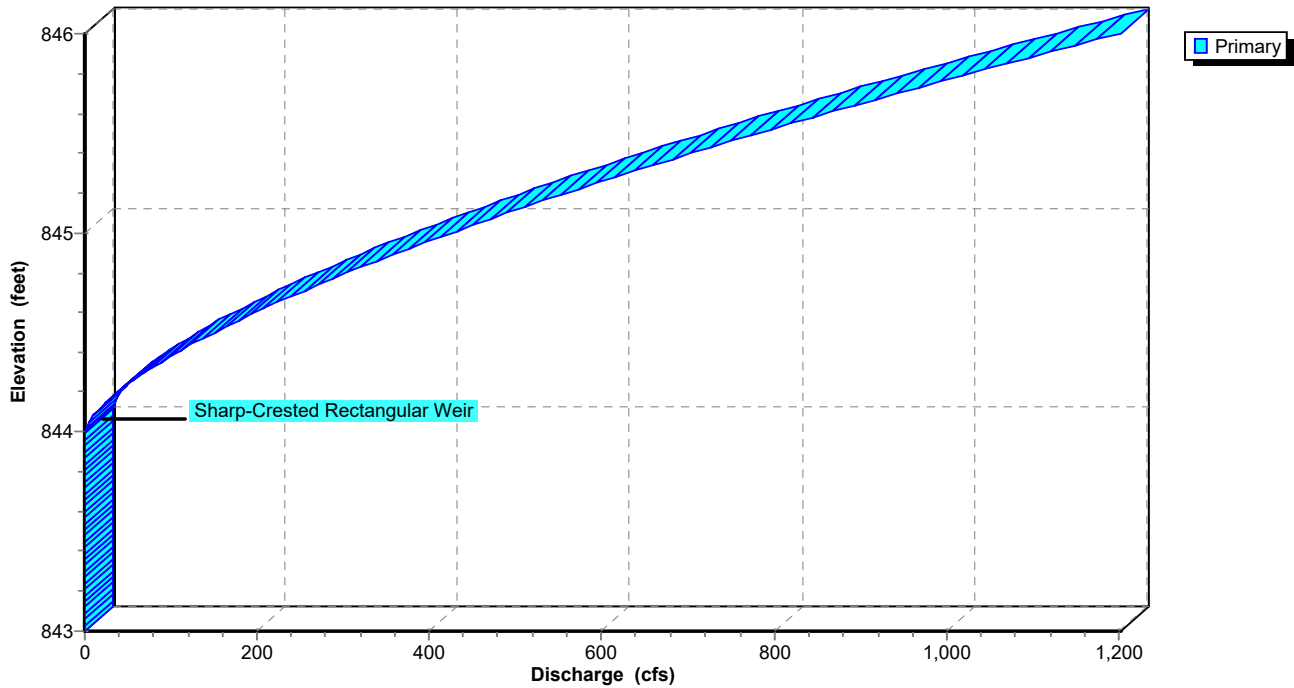

Pond P4A: Mine Ponds

Stage-Area-Storage

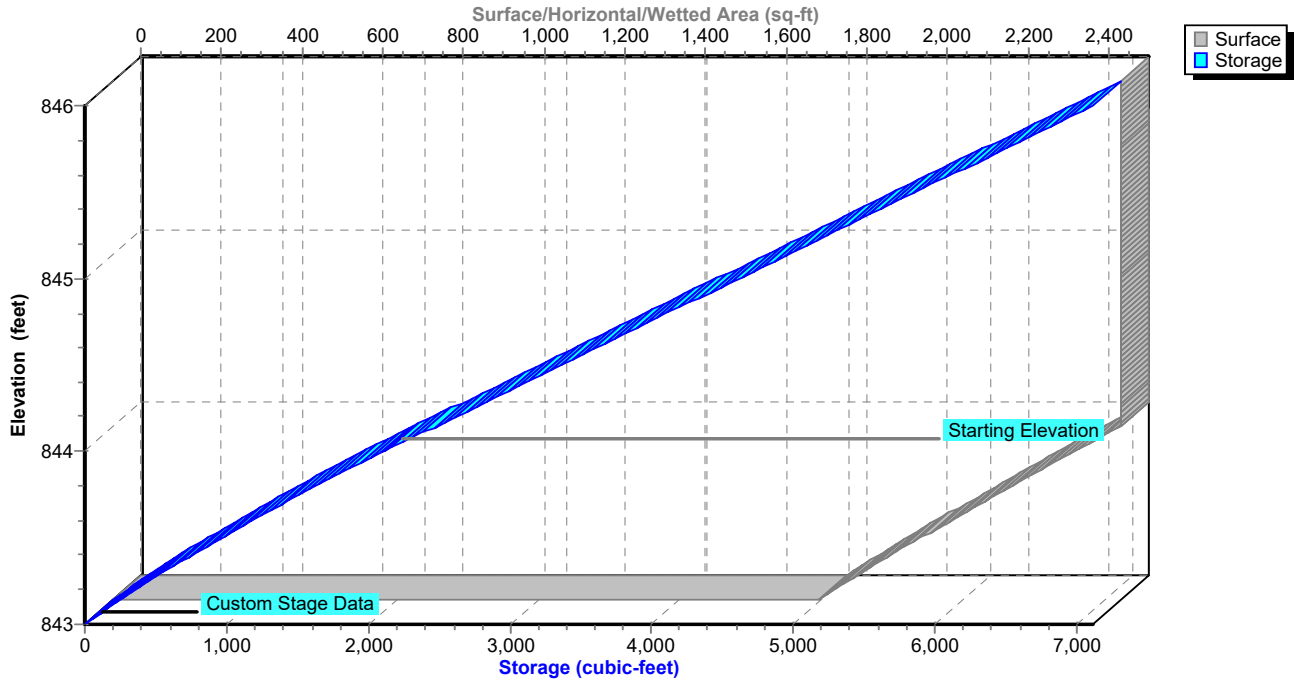

Hydrograph for Pond P4A: Mine Ponds

Time (hours)	Inflow (cfs)	Storage (cubic-feet)	Elevation (feet)	Primary (cfs)
0.05	0.00	2,114	844.00	0.00
2.55	0.00	2,114	844.00	0.00
5.05	0.00	2,114	844.00	0.00
7.55	0.00	2,114	844.00	0.00
10.05	0.48	2,134	844.01	0.47
12.55	5.25	2,247	844.05	5.29
15.05	1.90	2,179	844.03	1.90
17.55	1.25	2,165	844.02	1.25
20.05	0.86	2,150	844.01	0.86
22.55	0.78	2,146	844.01	0.78
25.05	0.00	2,114	844.00	0.00
27.55	0.00	2,114	844.00	0.00
30.05	0.00	2,114	844.00	0.00
32.55	0.00	2,114	844.00	0.00
35.05	0.00	2,114	844.00	0.00
37.55	0.00	2,114	844.00	0.00
40.05	0.00	2,114	844.00	0.00
42.55	0.00	2,114	844.00	0.00
45.05	0.00	2,114	844.00	0.00
47.55	0.00	2,114	844.00	0.00
50.05	0.00	2,114	844.00	0.00
52.55	0.00	2,114	844.00	0.00
55.05	0.00	2,114	844.00	0.00
57.55	0.00	2,114	844.00	0.00
60.05	0.00	2,114	844.00	0.00
62.55	0.00	2,114	844.00	0.00
65.05	0.00	2,114	844.00	0.00
67.55	0.00	2,114	844.00	0.00
70.05	0.00	2,114	844.00	0.00
72.55	0.00	2,114	844.00	0.00
75.05	0.00	2,114	844.00	0.00
77.55	0.00	2,114	844.00	0.00
80.05	0.00	2,114	844.00	0.00
82.55	0.00	2,114	844.00	0.00
85.05	0.00	2,114	844.00	0.00
87.55	0.00	2,114	844.00	0.00
90.05	0.00	2,114	844.00	0.00
92.55	0.00	2,114	844.00	0.00
95.05	0.00	2,114	844.00	0.00
97.55	0.00	2,114	844.00	0.00
100.05	0.00	2,114	844.00	0.00
102.55	0.00	2,114	844.00	0.00
105.05	0.00	2,114	844.00	0.00
107.55	0.00	2,114	844.00	0.00
110.05	0.00	2,114	844.00	0.00
112.55	0.00	2,114	844.00	0.00
115.05	0.00	2,114	844.00	0.00
117.55	0.00	2,114	844.00	0.00

Stage-Discharge for Pond P4A: Mine Ponds

Elevation (feet)	Primary (cfs)	Elevation (feet)	Primary (cfs)	Elevation (feet)	Primary (cfs)
843.00	0.00	844.04	3.40	845.08	477.12
843.02	0.00	844.06	6.25	845.10	490.43
843.04	0.00	844.08	9.62	845.12	503.87
843.06	0.00	844.10	13.44	845.14	517.43
843.08	0.00	844.12	17.67	845.16	531.10
843.10	0.00	844.14	22.27	845.18	544.90
843.12	0.00	844.16	27.21	845.20	558.81
843.14	0.00	844.18	32.46	845.22	572.84
843.16	0.00	844.20	38.02	845.24	586.98
843.18	0.00	844.22	43.87	845.26	601.24
843.20	0.00	844.24	49.98	845.28	615.61
843.22	0.00	844.26	56.36	845.30	630.10
843.24	0.00	844.28	62.98	845.32	644.69
843.26	0.00	844.30	69.85	845.34	659.40
843.28	0.00	844.32	76.95	845.36	674.22
843.30	0.00	844.34	84.28	845.38	689.14
843.32	0.00	844.36	91.82	845.40	704.18
843.34	0.00	844.38	99.58	845.42	719.32
843.36	0.00	844.40	107.54	845.44	734.57
843.38	0.00	844.42	115.71	845.46	749.93
843.40	0.00	844.44	124.07	845.48	765.39
843.42	0.00	844.46	132.63	845.50	780.96
843.44	0.00	844.48	141.37	845.52	796.63
843.46	0.00	844.50	150.30	845.54	812.40
843.48	0.00	844.52	159.40	845.56	828.28
843.50	0.00	844.54	168.69	845.58	844.26
843.52	0.00	844.56	178.14	845.60	860.34
843.54	0.00	844.58	187.77	845.62	876.52
843.56	0.00	844.60	197.57	845.64	892.81
843.58	0.00	844.62	207.53	845.66	909.19
843.60	0.00	844.64	217.65	845.68	925.67
843.62	0.00	844.66	227.93	845.70	942.25
843.64	0.00	844.68	238.37	845.72	958.92
843.66	0.00	844.70	248.96	845.74	975.70
843.68	0.00	844.72	259.71	845.76	992.57
843.70	0.00	844.74	270.61	845.78	1,009.53
843.72	0.00	844.76	281.65	845.80	1,026.60
843.74	0.00	844.78	292.84	845.82	1,043.75
843.76	0.00	844.80	304.18	845.84	1,061.01
843.78	0.00	844.82	315.65	845.86	1,078.35
843.80	0.00	844.84	327.27	845.88	1,095.79
843.82	0.00	844.86	339.03	845.90	1,113.32
843.84	0.00	844.88	350.93	845.92	1,130.95
843.86	0.00	844.90	362.96	845.94	1,148.67
843.88	0.00	844.92	375.12	845.96	1,166.47
843.90	0.00	844.94	387.42	845.98	1,184.37
843.92	0.00	844.96	399.85	846.00	1,202.36
843.94	0.00	844.98	412.41		
843.96	0.00	845.00	425.10		
843.98	0.00	845.02	437.92		
844.00	0.00	845.04	450.86		
844.02	1.20	845.06	463.93		

Stage-Area-Storage for Pond P4A: Mine Ponds

Elevation (feet)	Surface (sq-ft)	Storage (cubic-feet)	Elevation (feet)	Surface (sq-ft)	Storage (cubic-feet)
843.00	1,750	0	845.60	2,500	6,114
843.05	1,784	88	845.65	2,500	6,239
843.10	1,819	178	845.70	2,500	6,364
843.15	1,854	270	845.75	2,500	6,489
843.20	1,889	364	845.80	2,500	6,614
843.25	1,925	459	845.85	2,500	6,739
843.30	1,961	556	845.90	2,500	6,864
843.35	1,997	655	845.95	2,500	6,989
843.40	2,034	756	846.00	2,500	7,114
843.45	2,071	859			
843.50	2,108	963			
843.55	2,146	1,070			
843.60	2,184	1,178			
843.65	2,222	1,288			
843.70	2,261	1,400			
843.75	2,300	1,514			
843.80	2,339	1,630			
843.85	2,379	1,748			
843.90	2,419	1,868			
843.95	2,459	1,990			
844.00	2,500	2,114			
844.05	2,500	2,239			
844.10	2,500	2,364			
844.15	2,500	2,489			
844.20	2,500	2,614			
844.25	2,500	2,739			
844.30	2,500	2,864			
844.35	2,500	2,989			
844.40	2,500	3,114			
844.45	2,500	3,239			
844.50	2,500	3,364			
844.55	2,500	3,489			
844.60	2,500	3,614			
844.65	2,500	3,739			
844.70	2,500	3,864			
844.75	2,500	3,989			
844.80	2,500	4,114			
844.85	2,500	4,239			
844.90	2,500	4,364			
844.95	2,500	4,489			
845.00	2,500	4,614			
845.05	2,500	4,739			
845.10	2,500	4,864			
845.15	2,500	4,989			
845.20	2,500	5,114			
845.25	2,500	5,239			
845.30	2,500	5,364			
845.35	2,500	5,489			
845.40	2,500	5,614			
845.45	2,500	5,739			
845.50	2,500	5,864			
845.55	2,500	5,989			

IGN Padua Ridge Existing v4 w culvert

Type II 24-hr 25-yr Rainfall=4.39"

Prepared by JMT

Printed 1/31/2022

HydroCAD® 10.00-20 s/n 02102 © 2017 HydroCAD Software Solutions LLC

Page 86

Summary for Pond P4B: Mine Ponds

Inflow Area = 18.419 ac, 3.15% Impervious, Inflow Depth = 2.20" for 25-yr event
 Inflow = 78.42 cfs @ 11.93 hrs, Volume= 3.380 af
 Outflow = 78.09 cfs @ 11.94 hrs, Volume= 3.380 af, Atten= 0%, Lag= 0.2 min
 Primary = 78.09 cfs @ 11.94 hrs, Volume= 3.380 af

Routing by Stor-Ind method, Time Span= 0.05-120.00 hrs, dt= 0.05 hrs
 Starting Elev= 838.00' Surf.Area= 6,800 sf Storage= 5,003 cf
 Peak Elev= 838.18' @ 11.94 hrs Surf.Area= 7,051 sf Storage= 6,231 cf (1,228 cf above start)

Plug-Flow detention time= 27.4 min calculated for 3.264 af (97% of inflow)
 Center-of-Mass det. time= 0.6 min (827.7 - 827.2)

Volume	Invert	Avail.Storage	Storage Description
#1	837.00'	21,606 cf	Custom Stage Data (Conic) Listed below (Recalc)

Elevation (feet)	Surf.Area (sq-ft)	Inc.Store (cubic-feet)	Cum.Store (cubic-feet)	Wet.Area (sq-ft)
837.00	3,400	0	0	3,400
838.00	6,800	5,003	5,003	6,809
840.00	9,900	16,603	21,606	9,976

Device	Routing	Invert	Outlet Devices
#1	Primary	838.00'	320.0' long Sharp-Crested Rectangular Weir 0 End Contraction(s)

Primary OutFlow Max=74.50 cfs @ 11.94 hrs HW=838.17' (Free Discharge)

↑1=Sharp-Crested Rectangular Weir (Weir Controls 74.50 cfs @ 1.36 fps)

Pond P4B: Mine Ponds

Hydrograph

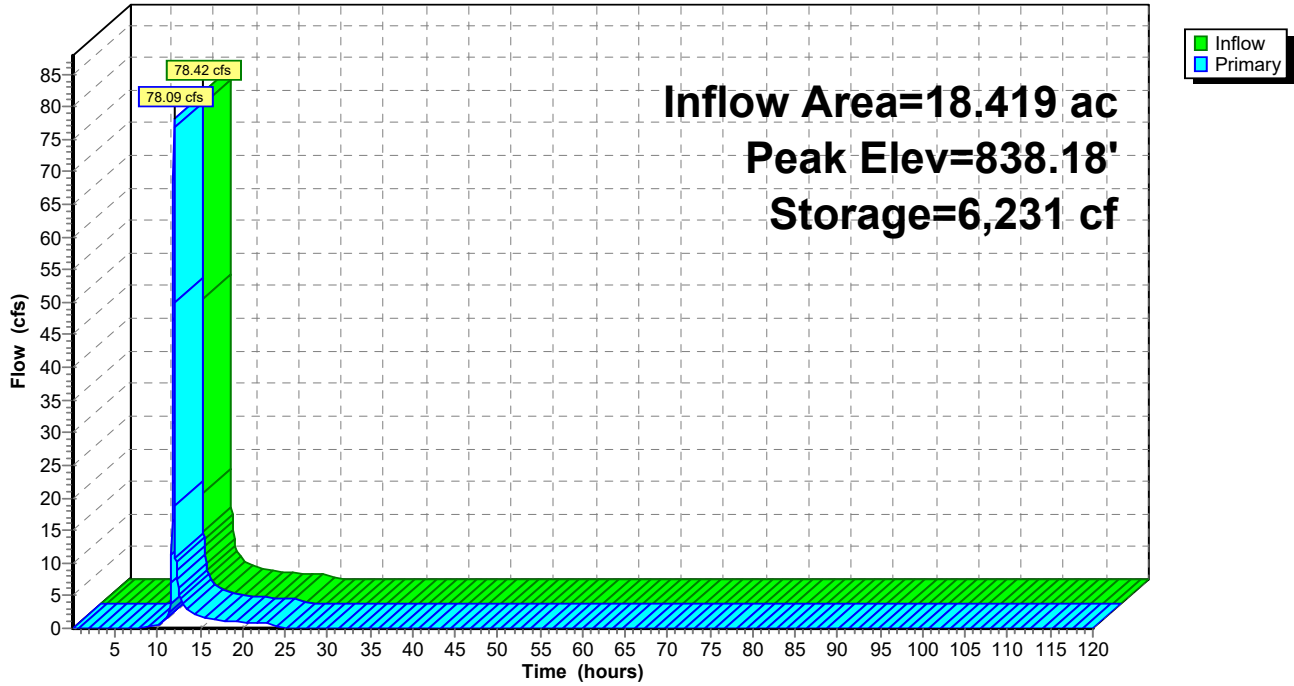

Pond P4B: Mine Ponds

Stage-Discharge

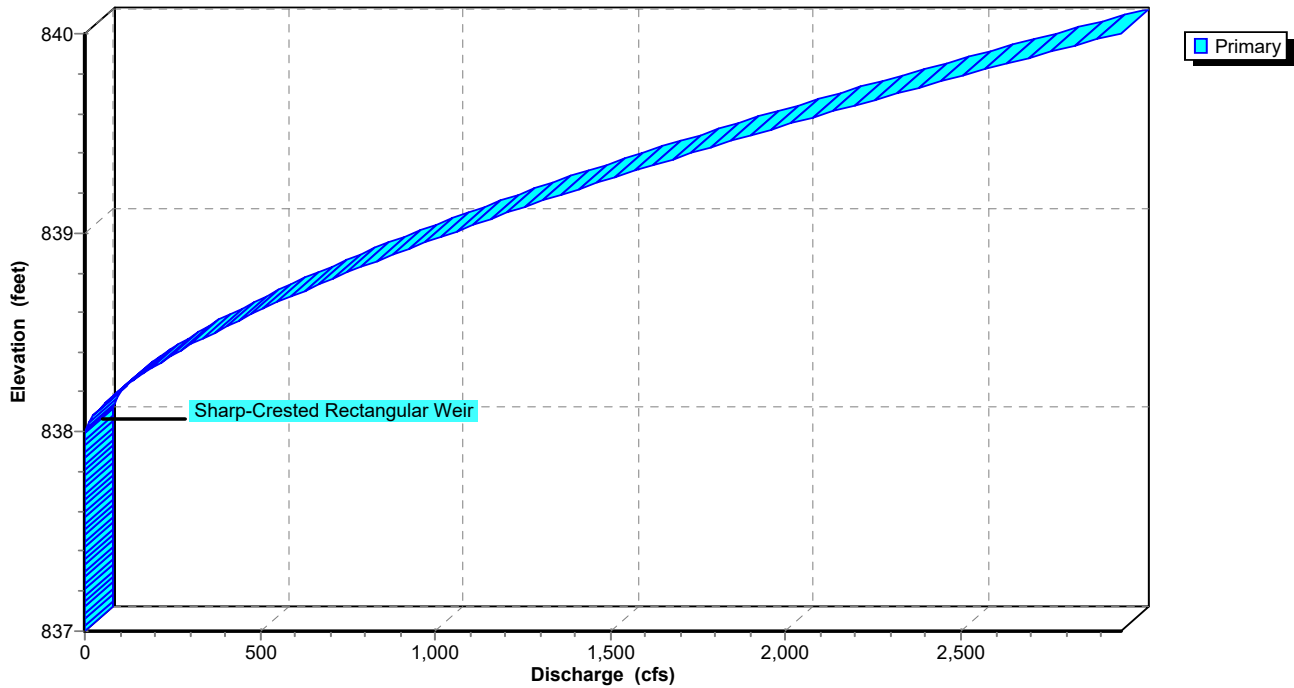

Pond P4B: Mine Ponds

Stage-Area-Storage

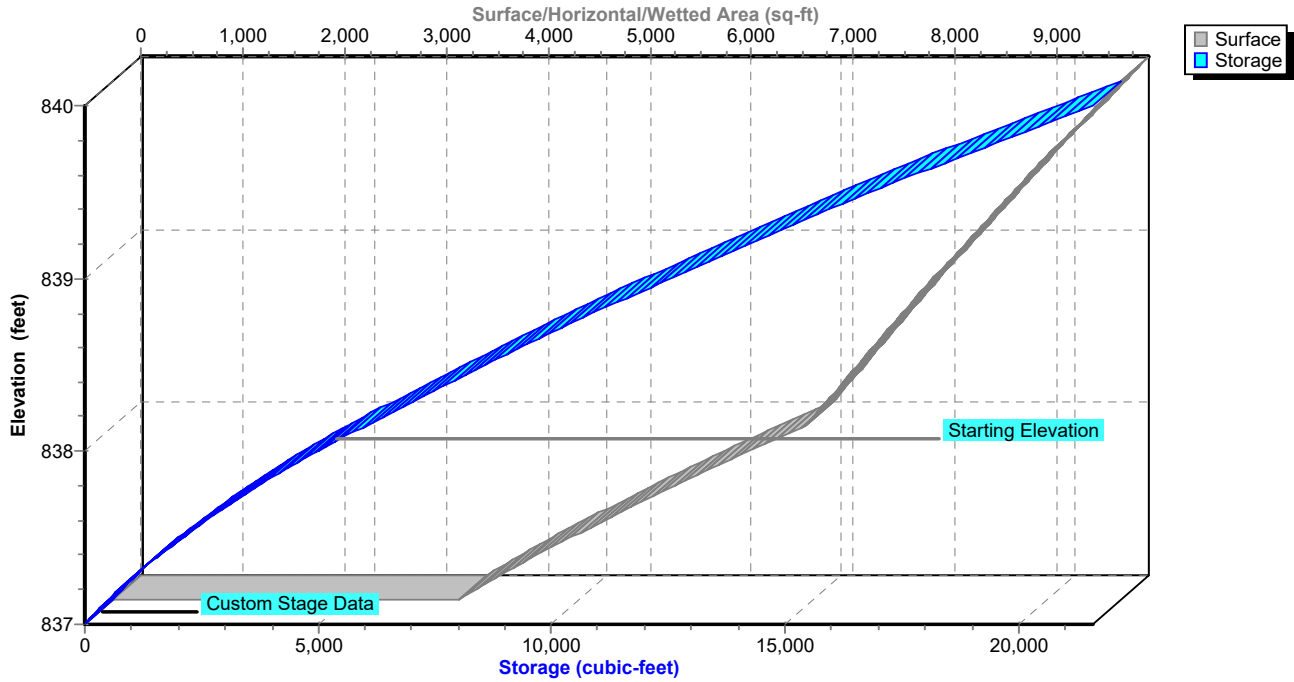

Hydrograph for Pond P4B: Mine Ponds

Time (hours)	Inflow (cfs)	Storage (cubic-feet)	Elevation (feet)	Primary (cfs)
0.05	0.00	5,003	838.00	0.00
2.55	0.00	5,003	838.00	0.00
5.05	0.00	5,003	838.00	0.00
7.55	0.00	5,003	838.00	0.00
10.05	0.47	5,024	838.00	0.47
12.55	5.29	5,195	838.03	5.33
15.05	1.90	5,091	838.01	1.91
17.55	1.25	5,060	838.01	1.25
20.05	0.86	5,042	838.01	0.86
22.55	0.78	5,039	838.01	0.78
25.05	0.00	5,003	838.00	0.00
27.55	0.00	5,003	838.00	0.00
30.05	0.00	5,003	838.00	0.00
32.55	0.00	5,003	838.00	0.00
35.05	0.00	5,003	838.00	0.00
37.55	0.00	5,003	838.00	0.00
40.05	0.00	5,003	838.00	0.00
42.55	0.00	5,003	838.00	0.00
45.05	0.00	5,003	838.00	0.00
47.55	0.00	5,003	838.00	0.00
50.05	0.00	5,003	838.00	0.00
52.55	0.00	5,003	838.00	0.00
55.05	0.00	5,003	838.00	0.00
57.55	0.00	5,003	838.00	0.00
60.05	0.00	5,003	838.00	0.00
62.55	0.00	5,003	838.00	0.00
65.05	0.00	5,003	838.00	0.00
67.55	0.00	5,003	838.00	0.00
70.05	0.00	5,003	838.00	0.00
72.55	0.00	5,003	838.00	0.00
75.05	0.00	5,003	838.00	0.00
77.55	0.00	5,003	838.00	0.00
80.05	0.00	5,003	838.00	0.00
82.55	0.00	5,003	838.00	0.00
85.05	0.00	5,003	838.00	0.00
87.55	0.00	5,003	838.00	0.00
90.05	0.00	5,003	838.00	0.00
92.55	0.00	5,003	838.00	0.00
95.05	0.00	5,003	838.00	0.00
97.55	0.00	5,003	838.00	0.00
100.05	0.00	5,003	838.00	0.00
102.55	0.00	5,003	838.00	0.00
105.05	0.00	5,003	838.00	0.00
107.55	0.00	5,003	838.00	0.00
110.05	0.00	5,003	838.00	0.00
112.55	0.00	5,003	838.00	0.00
115.05	0.00	5,003	838.00	0.00
117.55	0.00	5,003	838.00	0.00

Stage-Discharge for Pond P4B: Mine Ponds

Elevation (feet)	Primary (cfs)	Elevation (feet)	Primary (cfs)	Elevation (feet)	Primary (cfs)
837.00	0.00	838.04	8.37	839.08	1,174.45
837.02	0.00	838.06	15.38	839.10	1,207.22
837.04	0.00	838.08	23.68	839.12	1,240.29
837.06	0.00	838.10	33.09	839.14	1,273.66
837.08	0.00	838.12	43.50	839.16	1,307.33
837.10	0.00	838.14	54.81	839.18	1,341.28
837.12	0.00	838.16	66.97	839.20	1,375.53
837.14	0.00	838.18	79.91	839.22	1,410.06
837.16	0.00	838.20	93.59	839.24	1,444.87
837.18	0.00	838.22	107.98	839.26	1,479.97
837.20	0.00	838.24	123.03	839.28	1,515.35
837.22	0.00	838.26	138.73	839.30	1,551.00
837.24	0.00	838.28	155.04	839.32	1,586.93
837.26	0.00	838.30	171.94	839.34	1,623.14
837.28	0.00	838.32	189.42	839.36	1,659.61
837.30	0.00	838.34	207.45	839.38	1,696.35
837.32	0.00	838.36	226.02	839.40	1,733.36
837.34	0.00	838.38	245.12	839.42	1,770.64
837.36	0.00	838.40	264.72	839.44	1,808.18
837.38	0.00	838.42	284.82	839.46	1,845.98
837.40	0.00	838.44	305.41	839.48	1,884.04
837.42	0.00	838.46	326.46	839.50	1,922.36
837.44	0.00	838.48	347.98	839.52	1,960.93
837.46	0.00	838.50	369.96	839.54	1,999.76
837.48	0.00	838.52	392.38	839.56	2,038.85
837.50	0.00	838.54	415.23	839.58	2,078.18
837.52	0.00	838.56	438.51	839.60	2,117.76
837.54	0.00	838.58	462.21	839.62	2,157.60
837.56	0.00	838.60	486.32	839.64	2,197.68
837.58	0.00	838.62	510.84	839.66	2,238.00
837.60	0.00	838.64	535.76	839.68	2,278.57
837.62	0.00	838.66	561.07	839.70	2,319.38
837.64	0.00	838.68	586.76	839.72	2,360.43
837.66	0.00	838.70	612.84	839.74	2,401.72
837.68	0.00	838.72	639.29	839.76	2,443.24
837.70	0.00	838.74	666.11	839.78	2,485.01
837.72	0.00	838.76	693.30	839.80	2,527.01
837.74	0.00	838.78	720.84	839.82	2,569.24
837.76	0.00	838.80	748.74	839.84	2,611.71
837.78	0.00	838.82	777.00	839.86	2,654.40
837.80	0.00	838.84	805.59	839.88	2,697.33
837.82	0.00	838.86	834.54	839.90	2,740.49
837.84	0.00	838.88	863.82	839.92	2,783.87
837.86	0.00	838.90	893.43	839.94	2,827.49
837.88	0.00	838.92	923.38	839.96	2,871.32
837.90	0.00	838.94	953.65	839.98	2,915.38
837.92	0.00	838.96	984.25	840.00	2,959.67
837.94	0.00	838.98	1,015.17		
837.96	0.00	839.00	1,046.40		
837.98	0.00	839.02	1,077.95		
838.00	0.00	839.04	1,109.81		
838.02	2.96	839.06	1,141.97		

Stage-Area-Storage for Pond P4B: Mine Ponds

Elevation (feet)	Surface (sq-ft)	Storage (cubic-feet)	Elevation (feet)	Surface (sq-ft)	Storage (cubic-feet)
837.00	3,400	0	839.60	9,234	17,780
837.05	3,542	174	839.65	9,316	18,244
837.10	3,687	354	839.70	9,398	18,712
837.15	3,836	542	839.75	9,481	19,184
837.20	3,987	738	839.80	9,564	19,660
837.25	4,141	941	839.85	9,647	20,140
837.30	4,297	1,152	839.90	9,731	20,624
837.35	4,457	1,371	839.95	9,815	21,113
837.40	4,620	1,598	840.00	9,900	21,606
837.45	4,786	1,833			
837.50	4,954	2,076			
837.55	5,126	2,328			
837.60	5,300	2,589			
837.65	5,477	2,858			
837.70	5,657	3,137			
837.75	5,841	3,424			
837.80	6,027	3,721			
837.85	6,216	4,027			
837.90	6,407	4,342			
837.95	6,602	4,668			
838.00	6,800	5,003			
838.05	6,870	5,345			
838.10	6,941	5,690			
838.15	7,012	6,039			
838.20	7,084	6,391			
838.25	7,156	6,747			
838.30	7,228	7,107			
838.35	7,301	7,470			
838.40	7,374	7,837			
838.45	7,447	8,207			
838.50	7,521	8,581			
838.55	7,595	8,959			
838.60	7,669	9,341			
838.65	7,744	9,726			
838.70	7,819	10,115			
838.75	7,894	10,508			
838.80	7,970	10,905			
838.85	8,047	11,305			
838.90	8,123	11,709			
838.95	8,200	12,117			
839.00	8,277	12,529			
839.05	8,355	12,945			
839.10	8,433	13,365			
839.15	8,512	13,789			
839.20	8,590	14,216			
839.25	8,669	14,648			
839.30	8,749	15,083			
839.35	8,829	15,522			
839.40	8,909	15,966			
839.45	8,990	16,413			
839.50	9,071	16,865			
839.55	9,152	17,320			

Summary for Pond P4C: Mine Ponds

Inflow Area = 18.419 ac, 3.15% Impervious, Inflow Depth = 2.20" for 25-yr event
 Inflow = 78.09 cfs @ 11.94 hrs, Volume= 3.380 af
 Outflow = 4.08 cfs @ 12.94 hrs, Volume= 3.379 af, Atten= 95%, Lag= 60.1 min
 Primary = 4.08 cfs @ 12.94 hrs, Volume= 3.379 af

Routing by Stor-Ind method, Time Span= 0.05-120.00 hrs, dt= 0.05 hrs
 Starting Elev= 832.00' Surf.Area= 16,000 sf Storage= 12,610 cf
 Peak Elev= 835.25' @ 12.94 hrs Surf.Area= 32,273 sf Storage= 93,601 cf (80,992 cf above start)

Plug-Flow detention time= 983.9 min calculated for 3.089 af (91% of inflow)
 Center-of-Mass det. time= 851.1 min (1,678.9 - 827.7)

Volume	Invert	Avail.Storage	Storage Description	
#1	831.00'	118,924 cf	Custom Stage Data (Conic) Listed below (Recalc)	
Elevation (feet)	Surf.Area (sq-ft)	Inc.Store (cubic-feet)	Cum.Store (cubic-feet)	Wet.Area (sq-ft)
831.00	9,500	0	0	9,500
832.00	16,000	12,610	12,610	16,012
834.00	28,000	43,444	56,054	28,057
836.00	35,000	62,870	118,924	35,169

Device	Routing	Invert	Outlet Devices
#1	Primary	832.00'	24.0" Round Culvert L= 118.0' CPP, square edge headwall, Ke= 0.500 Inlet / Outlet Invert= 832.00' / 831.00' S= 0.0085 '/' Cc= 0.900 n= 0.012, Flow Area= 3.14 sf
#2	Device 1	832.00'	2.0" Vert. Orifice/Grate X 4.00 C= 0.600
#3	Device 1	834.80'	3.5' long x 0.50' rise Sharp-Crested Rectangular Weir 2 End Contraction(s)
#4	Device 1	835.30'	6.0' long Sharp-Crested Rectangular Weir 2 End Contraction(s)

Primary OutFlow Max=4.08 cfs @ 12.94 hrs HW=835.25' (Free Discharge)

- 1=Culvert (Passes 4.08 cfs of 22.67 cfs potential flow)
- 2=Orifice/Grate (Orifice Controls 0.75 cfs @ 8.56 fps)
- 3=Sharp-Crested Rectangular Weir (Weir Controls 3.33 cfs @ 2.19 fps)
- 4=Sharp-Crested Rectangular Weir (Controls 0.00 cfs)

Pond P4C: Mine Ponds

Hydrograph

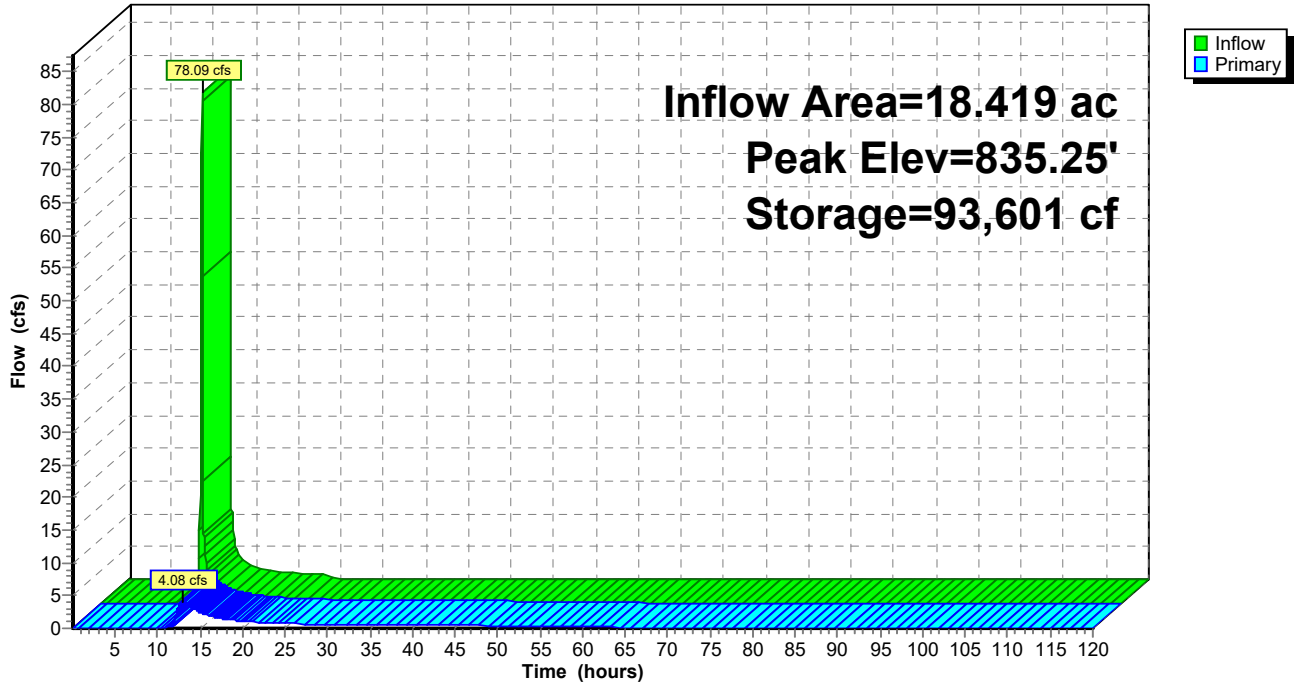

Pond P4C: Mine Ponds

Stage-Discharge

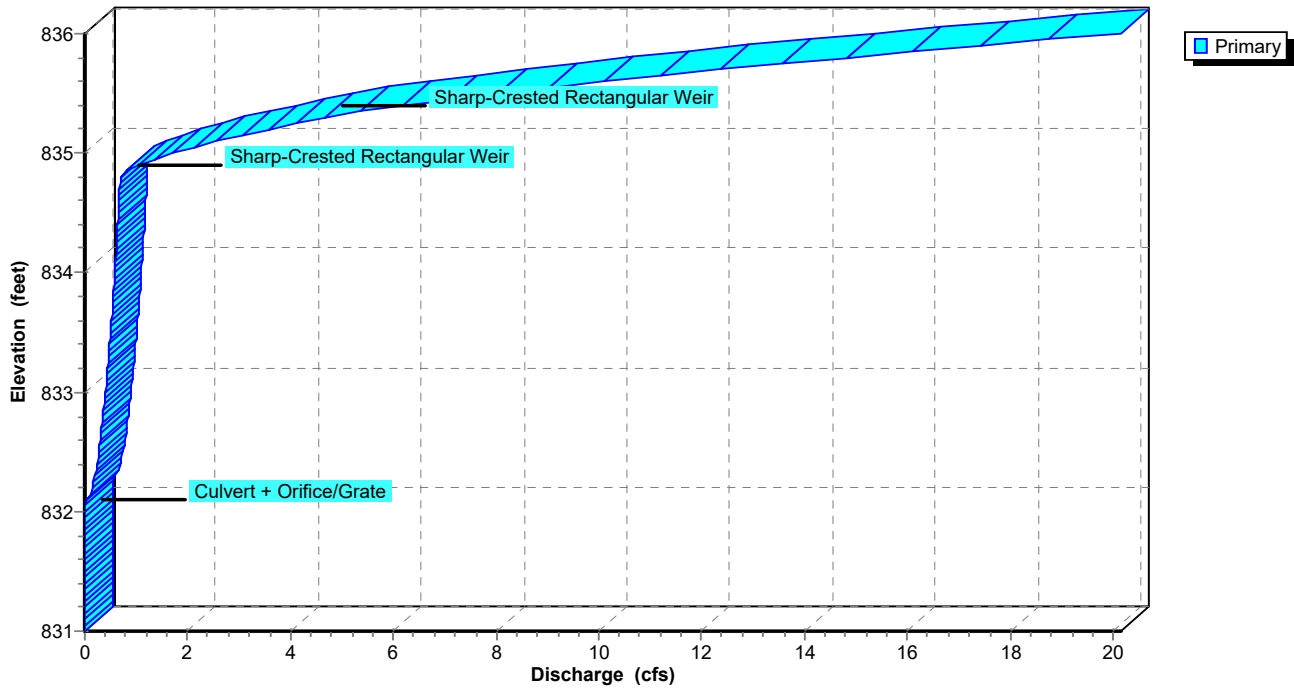

Pond P4C: Mine Ponds

Stage-Area-Storage

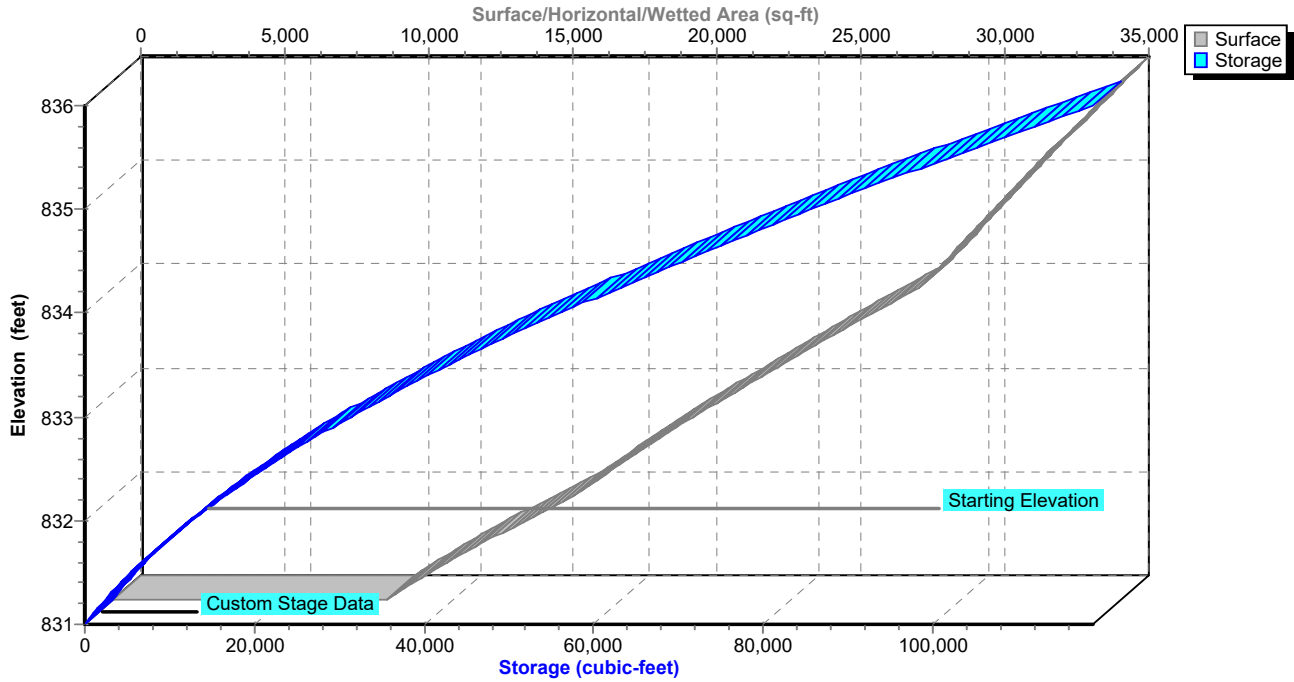

Hydrograph for Pond P4C: Mine Ponds

Time (hours)	Inflow (cfs)	Storage (cubic-feet)	Elevation (feet)	Primary (cfs)
0.05	0.00	12,610	832.00	0.00
2.55	0.00	12,610	832.00	0.00
5.05	0.00	12,610	832.00	0.00
7.55	0.00	12,610	832.00	0.00
10.05	0.47	13,713	832.07	0.03
12.55	5.33	92,643	835.22	3.76
15.05	1.91	88,507	835.09	2.47
17.55	1.25	84,802	834.97	1.51
20.05	0.86	82,718	834.90	1.09
22.55	0.78	81,405	834.86	0.88
25.05	0.00	78,382	834.76	0.69
27.55	0.00	72,310	834.56	0.66
30.05	0.00	66,477	834.36	0.63
32.55	0.00	60,889	834.17	0.61
35.05	0.00	55,551	833.98	0.58
37.55	0.00	50,471	833.80	0.55
40.05	0.00	45,659	833.61	0.52
42.55	0.00	41,129	833.43	0.49
45.05	0.00	36,894	833.25	0.45
47.55	0.00	32,968	833.07	0.42
50.05	0.00	29,368	832.91	0.38
52.55	0.00	26,107	832.75	0.34
55.05	0.00	23,202	832.60	0.30
57.55	0.00	20,668	832.47	0.26
60.05	0.00	18,521	832.35	0.22
62.55	0.00	16,775	832.25	0.17
65.05	0.00	15,443	832.17	0.12
67.55	0.00	14,538	832.12	0.08
70.05	0.00	14,007	832.09	0.05
72.55	0.00	13,685	832.07	0.03
75.05	0.00	13,488	832.05	0.02
77.55	0.00	13,363	832.05	0.01
80.05	0.00	13,260	832.04	0.01
82.55	0.00	13,172	832.03	0.01
85.05	0.00	13,095	832.03	0.01
87.55	0.00	13,029	832.03	0.01
90.05	0.00	12,972	832.02	0.01
92.55	0.00	12,922	832.02	0.01
95.05	0.00	12,880	832.02	0.00
97.55	0.00	12,843	832.01	0.00
100.05	0.00	12,811	832.01	0.00
102.55	0.00	12,784	832.01	0.00
105.05	0.00	12,760	832.01	0.00
107.55	0.00	12,740	832.01	0.00
110.05	0.00	12,722	832.01	0.00
112.55	0.00	12,707	832.01	0.00
115.05	0.00	12,693	832.01	0.00
117.55	0.00	12,682	832.00	0.00

IGN Padua Ridge Existing v4 w culvert

Type II 24-hr 25-yr Rainfall=4.39"

Prepared by JMT

Printed 1/31/2022

HydroCAD® 10.00-20 s/n 02102 © 2017 HydroCAD Software Solutions LLC

Page 96

Stage-Discharge for Pond P4C: Mine Ponds

Elevation (feet)	Primary (cfs)	Elevation (feet)	Primary (cfs)
831.00	0.00	833.60	0.52
831.05	0.00	833.65	0.53
831.10	0.00	833.70	0.53
831.15	0.00	833.75	0.54
831.20	0.00	833.80	0.55
831.25	0.00	833.85	0.56
831.30	0.00	833.90	0.57
831.35	0.00	833.95	0.57
831.40	0.00	834.00	0.58
831.45	0.00	834.05	0.59
831.50	0.00	834.10	0.60
831.55	0.00	834.15	0.60
831.60	0.00	834.20	0.61
831.65	0.00	834.25	0.62
831.70	0.00	834.30	0.63
831.75	0.00	834.35	0.63
831.80	0.00	834.40	0.64
831.85	0.00	834.45	0.65
831.90	0.00	834.50	0.65
831.95	0.00	834.55	0.66
832.00	0.00	834.60	0.67
832.05	0.01	834.65	0.67
832.10	0.06	834.70	0.68
832.15	0.11	834.75	0.69
832.20	0.14	834.80	0.69
832.25	0.17	834.85	0.83
832.30	0.20	834.90	1.07
832.35	0.22	834.95	1.37
832.40	0.24	835.00	1.73
832.45	0.25	835.05	2.13
832.50	0.27	835.10	2.58
832.55	0.29	835.15	3.06
832.60	0.30	835.20	3.57
832.65	0.32	835.25	4.11
832.70	0.33	835.30	4.68
832.75	0.34	835.35	5.39
832.80	0.36	835.40	6.20
832.85	0.37	835.45	7.09
832.90	0.38	835.50	8.04
832.95	0.39	835.55	9.05
833.00	0.40	835.60	10.11
833.05	0.41	835.65	11.22
833.10	0.42	835.70	12.38
833.15	0.43	835.75	13.58
833.20	0.44	835.80	14.82
833.25	0.45	835.85	16.10
833.30	0.46	835.90	17.42
833.35	0.47	835.95	18.77
833.40	0.48	836.00	20.16
833.45	0.49		
833.50	0.50		
833.55	0.51		

IGN Padua Ridge Existing v4 w culvert

Type II 24-hr 25-yr Rainfall=4.39"

Prepared by JMT

Printed 1/31/2022

HydroCAD® 10.00-20 s/n 02102 © 2017 HydroCAD Software Solutions LLC

Page 97

Stage-Area-Storage for Pond P4C: Mine Ponds

Elevation (feet)	Surface (sq-ft)	Storage (cubic-feet)	Elevation (feet)	Surface (sq-ft)	Storage (cubic-feet)
831.00	9,500	0	833.60	25,333	45,391
831.05	9,785	482	833.65	25,659	46,666
831.10	10,074	979	833.70	25,987	47,957
831.15	10,368	1,490	833.75	26,318	49,265
831.20	10,665	2,015	833.80	26,650	50,589
831.25	10,967	2,556	833.85	26,984	51,930
831.30	11,273	3,112	833.90	27,321	53,288
831.35	11,583	3,684	833.95	27,659	54,662
831.40	11,898	4,271	834.00	28,000	56,054
831.45	12,217	4,873	834.05	28,165	57,458
831.50	12,539	5,492	834.10	28,331	58,870
831.55	12,867	6,127	834.15	28,498	60,291
831.60	13,198	6,779	834.20	28,665	61,720
831.65	13,533	7,447	834.25	28,832	63,157
831.70	13,873	8,132	834.30	29,000	64,603
831.75	14,217	8,835	834.35	29,169	66,057
831.80	14,565	9,554	834.40	29,338	67,520
831.85	14,918	10,291	834.45	29,507	68,991
831.90	15,274	11,046	834.50	29,677	70,471
831.95	15,635	11,819	834.55	29,847	71,959
832.00	16,000	12,610	834.60	30,018	73,456
832.05	16,259	13,416	834.65	30,189	74,961
832.10	16,521	14,236	834.70	30,361	76,474
832.15	16,784	15,068	834.75	30,534	77,997
832.20	17,050	15,914	834.80	30,706	79,528
832.25	17,318	16,773	834.85	30,880	81,067
832.30	17,587	17,646	834.90	31,053	82,616
832.35	17,859	18,532	834.95	31,228	84,173
832.40	18,133	19,432	835.00	31,402	85,739
832.45	18,409	20,345	835.05	31,578	87,313
832.50	18,687	21,273	835.10	31,753	88,896
832.55	18,967	22,214	835.15	31,930	90,488
832.60	19,250	23,170	835.20	32,106	92,089
832.65	19,534	24,139	835.25	32,284	93,699
832.70	19,821	25,123	835.30	32,461	95,318
832.75	20,109	26,121	835.35	32,639	96,945
832.80	20,400	27,134	835.40	32,818	98,582
832.85	20,692	28,161	835.45	32,997	100,227
832.90	20,987	29,203	835.50	33,177	101,881
832.95	21,284	30,260	835.55	33,357	103,545
833.00	21,583	31,332	835.60	33,538	105,217
833.05	21,884	32,418	835.65	33,719	106,899
833.10	22,187	33,520	835.70	33,900	108,589
833.15	22,492	34,637	835.75	34,082	110,289
833.20	22,800	35,769	835.80	34,265	111,997
833.25	23,109	36,917	835.85	34,448	113,715
833.30	23,421	38,080	835.90	34,631	115,442
833.35	23,734	39,259	835.95	34,815	117,178
833.40	24,050	40,454	836.00	35,000	118,924
833.45	24,367	41,664			
833.50	24,687	42,890			
833.55	25,009	44,133			

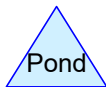
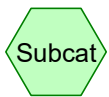
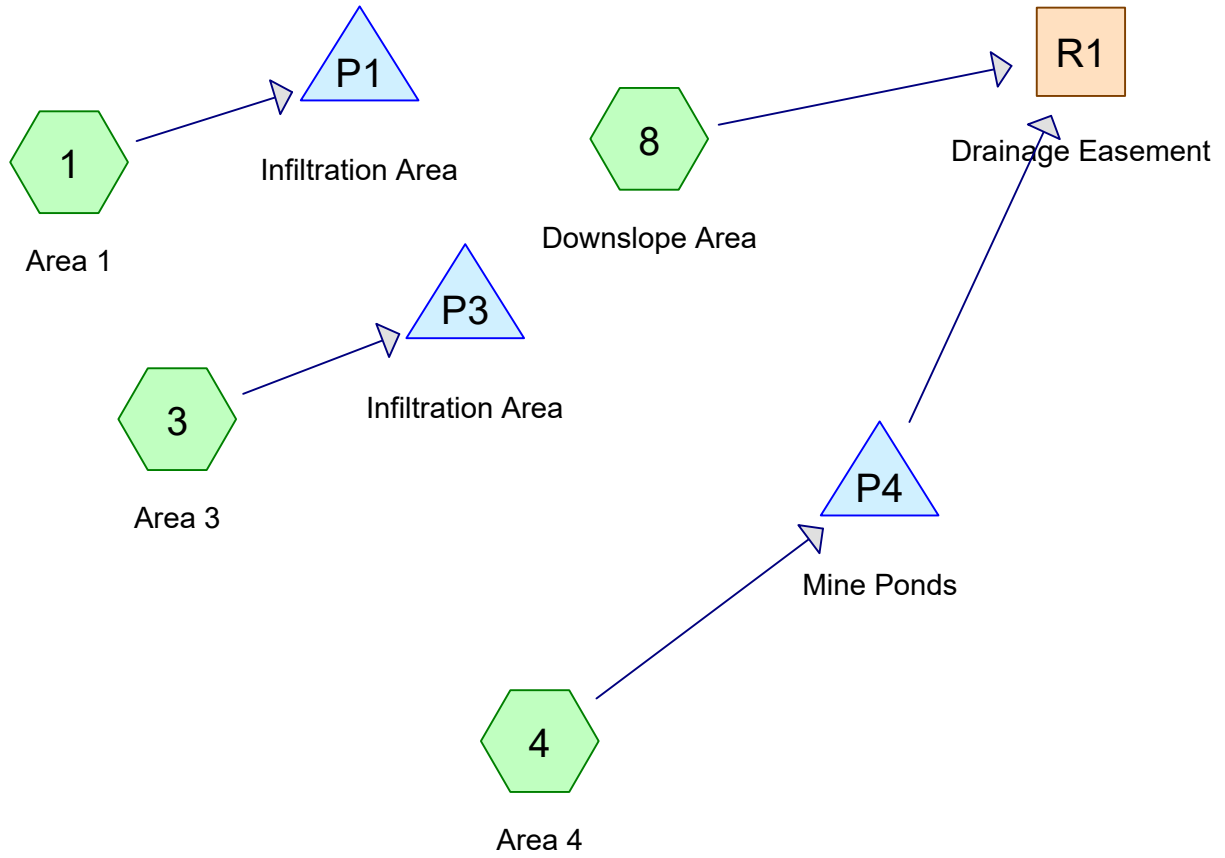

Routing Diagram for IGN Padua Ridge Pre-Reclaimed v2 sharp we

Prepared by JMT, Printed 1/31/2022

HydroCAD® 10.00-20 s/n 02102 © 2017 HydroCAD Software Solutions LLC

IGN Padua Ridge Pre-Reclaimed v2 sharp weir

Prepared by JMT

HydroCAD® 10.00-20 s/n 02102 © 2017 HydroCAD Software Solutions LLC

Printed 1/31/2022

Page 2

Area Listing (all nodes)

Area (acres)	CN	Description (subcatchment-numbers)
3.119	85	Gravel roads, HSG B (1, 3, 8)
60.300	77	Newly graded area, HSG A (4)
0.530	98	Water Surface, HSG A (4)
5.674	30	Woods, Good, HSG A (1, 3)
3.189	32	Woods/grass comb., Good, HSG A (8)
7.687	58	Woods/grass comb., Good, HSG B (1, 3, 8)
20.140	79	Woods/grass comb., Good, HSG D (8)
100.638	72	TOTAL AREA

IGN Padua Ridge Pre-Reclaimed v2 sharp weir

Prepared by JMT

HydroCAD® 10.00-20 s/n 02102 © 2017 HydroCAD Software Solutions LLC

Printed 1/31/2022

Page 3

Soil Listing (all nodes)

Area (acres)	Soil Group	Subcatchment Numbers
69.692	HSG A	1, 3, 4, 8
10.806	HSG B	1, 3, 8
0.000	HSG C	
20.140	HSG D	8
0.000	Other	
100.638		TOTAL AREA

IGN Padua Ridge Pre-Reclaimed v2 sharp weir

Prepared by JMT

HydroCAD® 10.00-20 s/n 02102 © 2017 HydroCAD Software Solutions LLC

Printed 1/31/2022

Page 4

Ground Covers (all nodes)

HSG-A (acres)	HSG-B (acres)	HSG-C (acres)	HSG-D (acres)	Other (acres)	Total (acres)	Ground Cover	Subcatchment Numbers
0.000	3.119	0.000	0.000	0.000	3.119	Gravel roads	1, 3, 8
60.300	0.000	0.000	0.000	0.000	60.300	Newly graded area	4
0.530	0.000	0.000	0.000	0.000	0.530	Water Surface	4
5.674	0.000	0.000	0.000	0.000	5.674	Woods, Good	1, 3
3.189	7.687	0.000	20.140	0.000	31.016	Woods/grass comb., Good	1, 3, 8
69.692	10.806	0.000	20.140	0.000	100.638	TOTAL AREA	

IGN Padua Ridge Pre-Reclaimed v2 sharp weir

Prepared by JMT

HydroCAD® 10.00-20 s/n 02102 © 2017 HydroCAD Software Solutions LLC

Printed 1/31/2022

Page 5

Pipe Listing (all nodes)

Line#	Node Number	In-Invert (feet)	Out-Invert (feet)	Length (feet)	Slope (ft/ft)	n	Diam/Width (inches)	Height (inches)	Inside-Fill (inches)
1	P4	832.00	831.00	118.0	0.0085	0.013	24.0	0.0	0.0

IGN Padua Ridge Pre-Reclaimed v2 sharp weir

Type II 24-hr 10-yr Rainfall=3.61"

Prepared by JMT

Printed 1/31/2022

HydroCAD® 10.00-20 s/n 02102 © 2017 HydroCAD Software Solutions LLC

Page 6

Time span=0.05-168.00 hrs, dt=0.05 hrs, 3360 points
 Runoff by SCS TR-20 method, UH=SCS, Weighted-CN
 Reach routing by Stor-Ind+Trans method - Pond routing by Stor-Ind method

Subcatchment1: Area 1	Runoff Area=279,272 sf 0.00% Impervious Runoff Depth=0.42" Flow Length=853' Tc=11.1 min CN=56 Runoff=2.51 cfs 0.224 af
Subcatchment3: Area 3	Runoff Area=240,062 sf 0.00% Impervious Runoff Depth=0.06" Flow Length=800' Tc=12.2 min CN=43 Runoff=0.04 cfs 0.030 af
Subcatchment4: Area 4	Runoff Area=60.830 ac 0.87% Impervious Runoff Depth=1.51" Flow Length=2,350' Tc=28.1 min CN=77 Runoff=81.16 cfs 7.668 af
Subcatchment8: Downslope Area	Runoff Area=1,214,716 sf 0.00% Impervious Runoff Depth=1.13" Flow Length=850' Tc=17.7 min CN=71 Runoff=35.51 cfs 2.636 af
Reach R1: Drainage Easement	Avg. Flow Depth=1.76' Max Vel=6.15 fps Inflow=36.69 cfs 10.304 af n=0.030 L=1,890.0' S=0.0180 '/' Capacity=97.49 cfs Outflow=32.87 cfs 10.304 af
Pond P1: Infiltration Area	Peak Elev=855.39' Storage=4,446 cf Inflow=2.51 cfs 0.224 af Outflow=0.13 cfs 0.224 af
Pond P3: Infiltration Area	Peak Elev=855.01' Storage=63 cf Inflow=0.04 cfs 0.030 af Outflow=0.04 cfs 0.030 af
Pond P4: Mine Ponds	Peak Elev=838.33' Storage=286,982 cf Inflow=81.16 cfs 7.668 af Outflow=3.44 cfs 7.668 af
Total Runoff Area = 100.638 ac Runoff Volume = 10.558 af Average Runoff Depth = 1.26"	
99.47% Pervious = 100.108 ac 0.53% Impervious = 0.530 ac	

Summary for Subcatchment 1: Area 1

Runoff = 2.51 cfs @ 12.07 hrs, Volume= 0.224 af, Depth= 0.42"

Runoff by SCS TR-20 method, UH=SCS, Weighted-CN, Time Span= 0.05-168.00 hrs, dt= 0.05 hrs
Type II 24-hr 10-yr Rainfall=3.61"

Area (sf)	CN	Description
56,691	85	Gravel roads, HSG B
144,643	58	Woods/grass comb., Good, HSG B
77,938	30	Woods, Good, HSG A
279,272	56	Weighted Average
279,272		100.00% Pervious Area

Tc (min)	Length (feet)	Slope (ft/ft)	Velocity (ft/sec)	Capacity (cfs)	Description
3.9	100	0.3000	0.43		Sheet Flow, Grass: Short n= 0.150 P2= 2.35"
2.6	415	0.1400	2.62		Shallow Concentrated Flow, Short Grass Pasture Kv= 7.0 fps
4.6	338	0.0300	1.21		Shallow Concentrated Flow, Short Grass Pasture Kv= 7.0 fps
11.1	853	Total			

Subcatchment 1: Area 1

Hydrograph

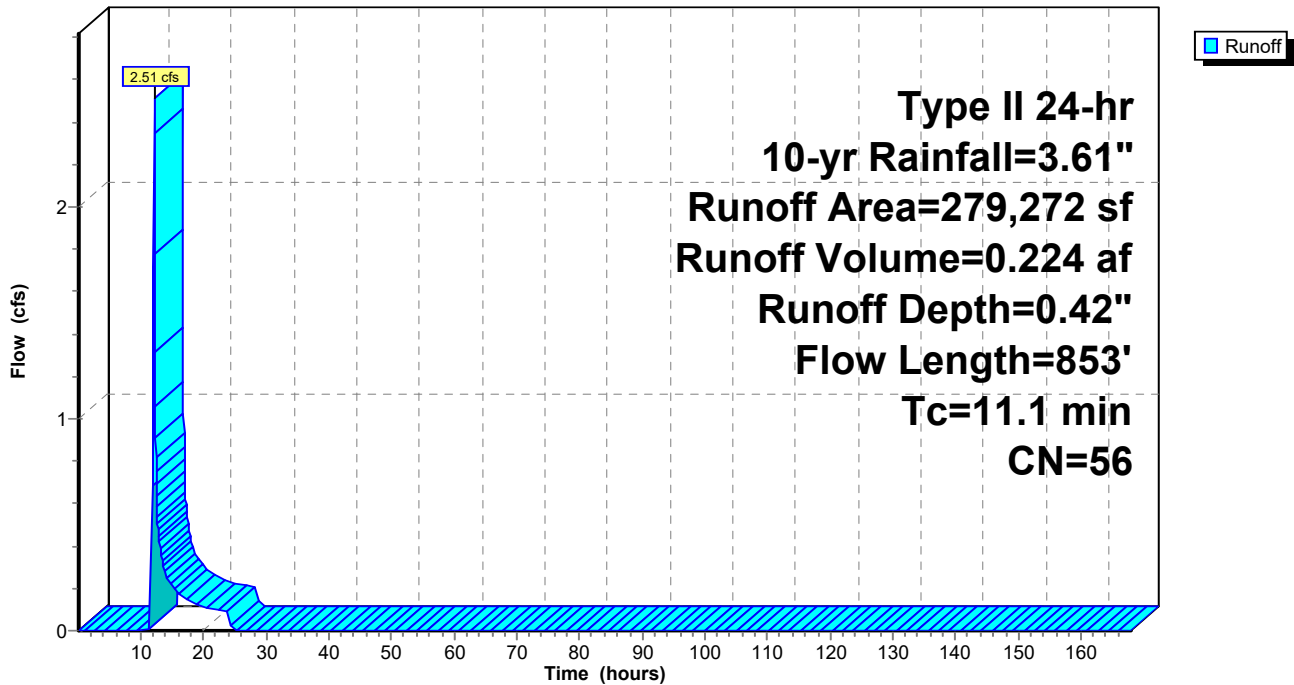

Hydrograph for Subcatchment 1: Area 1

Time (hours)	Precip. (inches)	Excess (inches)	Runoff (cfs)	Time (hours)	Precip. (inches)	Excess (inches)	Runoff (cfs)
0.05	0.00	0.00	0.00	130.05	3.61	0.42	0.00
2.55	0.10	0.00	0.00	132.55	3.61	0.42	0.00
5.05	0.23	0.00	0.00	135.05	3.61	0.42	0.00
7.55	0.40	0.00	0.00	137.55	3.61	0.42	0.00
10.05	0.66	0.00	0.00	140.05	3.61	0.42	0.00
12.55	2.67	0.13	0.59	142.55	3.61	0.42	0.00
15.05	3.09	0.24	0.21	145.05	3.61	0.42	0.00
17.55	3.29	0.31	0.15	147.55	3.61	0.42	0.00
20.05	3.44	0.36	0.11	150.05	3.61	0.42	0.00
22.55	3.55	0.40	0.10	152.55	3.61	0.42	0.00
25.05	3.61	0.42	0.00	155.05	3.61	0.42	0.00
27.55	3.61	0.42	0.00	157.55	3.61	0.42	0.00
30.05	3.61	0.42	0.00	160.05	3.61	0.42	0.00
32.55	3.61	0.42	0.00	162.55	3.61	0.42	0.00
35.05	3.61	0.42	0.00	165.05	3.61	0.42	0.00
37.55	3.61	0.42	0.00	167.55	3.61	0.42	0.00
40.05	3.61	0.42	0.00				
42.55	3.61	0.42	0.00				
45.05	3.61	0.42	0.00				
47.55	3.61	0.42	0.00				
50.05	3.61	0.42	0.00				
52.55	3.61	0.42	0.00				
55.05	3.61	0.42	0.00				
57.55	3.61	0.42	0.00				
60.05	3.61	0.42	0.00				
62.55	3.61	0.42	0.00				
65.05	3.61	0.42	0.00				
67.55	3.61	0.42	0.00				
70.05	3.61	0.42	0.00				
72.55	3.61	0.42	0.00				
75.05	3.61	0.42	0.00				
77.55	3.61	0.42	0.00				
80.05	3.61	0.42	0.00				
82.55	3.61	0.42	0.00				
85.05	3.61	0.42	0.00				
87.55	3.61	0.42	0.00				
90.05	3.61	0.42	0.00				
92.55	3.61	0.42	0.00				
95.05	3.61	0.42	0.00				
97.55	3.61	0.42	0.00				
100.05	3.61	0.42	0.00				
102.55	3.61	0.42	0.00				
105.05	3.61	0.42	0.00				
107.55	3.61	0.42	0.00				
110.05	3.61	0.42	0.00				
112.55	3.61	0.42	0.00				
115.05	3.61	0.42	0.00				
117.55	3.61	0.42	0.00				
120.05	3.61	0.42	0.00				
122.55	3.61	0.42	0.00				
125.05	3.61	0.42	0.00				
127.55	3.61	0.42	0.00				

Summary for Subcatchment 3: Area 3

Runoff = 0.04 cfs @ 15.22 hrs, Volume= 0.030 af, Depth= 0.06"

Runoff by SCS TR-20 method, UH=SCS, Weighted-CN, Time Span= 0.05-168.00 hrs, dt= 0.05 hrs
 Type II 24-hr 10-yr Rainfall=3.61"

Area (sf)	CN	Description
45,301	85	Gravel roads, HSG B
25,552	58	Woods/grass comb., Good, HSG B
169,209	30	Woods, Good, HSG A
240,062	43	Weighted Average
240,062		100.00% Pervious Area

Tc (min)	Length (feet)	Slope (ft/ft)	Velocity (ft/sec)	Capacity (cfs)	Description
6.2	100	0.6600	0.27		Sheet Flow, Woods: Light underbrush n= 0.400 P2= 2.35"
3.1	450	0.1200	2.42		Shallow Concentrated Flow, Short Grass Pasture Kv= 7.0 fps
1.9	110	0.0200	0.99		Shallow Concentrated Flow, Short Grass Pasture Kv= 7.0 fps
1.0	140	0.1100	2.32		Shallow Concentrated Flow, Short Grass Pasture Kv= 7.0 fps
12.2	800	Total			

Subcatchment 3: Area 3

Hydrograph

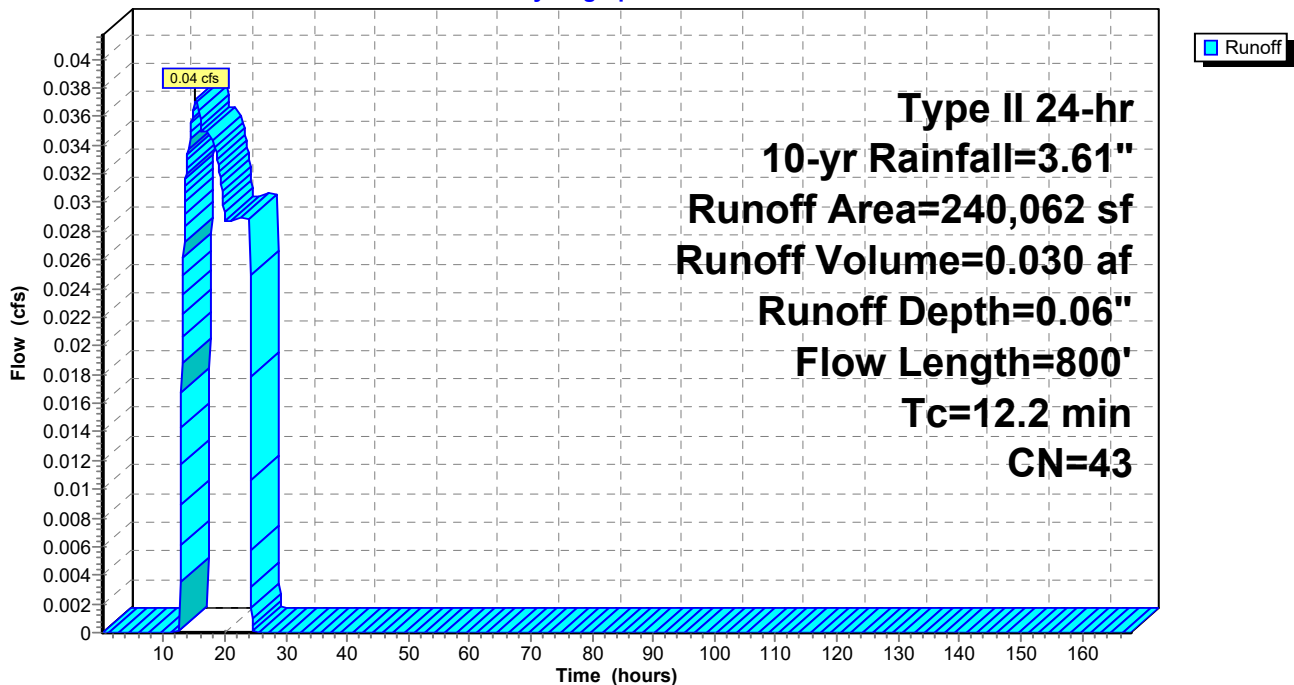

Hydrograph for Subcatchment 3: Area 3

Time (hours)	Precip. (inches)	Excess (inches)	Runoff (cfs)	Time (hours)	Precip. (inches)	Excess (inches)	Runoff (cfs)
0.05	0.00	0.00	0.00	130.05	3.61	0.06	0.00
2.55	0.10	0.00	0.00	132.55	3.61	0.06	0.00
5.05	0.23	0.00	0.00	135.05	3.61	0.06	0.00
7.55	0.40	0.00	0.00	137.55	3.61	0.06	0.00
10.05	0.66	0.00	0.00	140.05	3.61	0.06	0.00
12.55	2.67	0.00	0.00	142.55	3.61	0.06	0.00
15.05	3.09	0.01	0.04	145.05	3.61	0.06	0.00
17.55	3.29	0.03	0.03	147.55	3.61	0.06	0.00
20.05	3.44	0.04	0.03	150.05	3.61	0.06	0.00
22.55	3.55	0.06	0.03	152.55	3.61	0.06	0.00
25.05	3.61	0.06	0.00	155.05	3.61	0.06	0.00
27.55	3.61	0.06	0.00	157.55	3.61	0.06	0.00
30.05	3.61	0.06	0.00	160.05	3.61	0.06	0.00
32.55	3.61	0.06	0.00	162.55	3.61	0.06	0.00
35.05	3.61	0.06	0.00	165.05	3.61	0.06	0.00
37.55	3.61	0.06	0.00	167.55	3.61	0.06	0.00
40.05	3.61	0.06	0.00				
42.55	3.61	0.06	0.00				
45.05	3.61	0.06	0.00				
47.55	3.61	0.06	0.00				
50.05	3.61	0.06	0.00				
52.55	3.61	0.06	0.00				
55.05	3.61	0.06	0.00				
57.55	3.61	0.06	0.00				
60.05	3.61	0.06	0.00				
62.55	3.61	0.06	0.00				
65.05	3.61	0.06	0.00				
67.55	3.61	0.06	0.00				
70.05	3.61	0.06	0.00				
72.55	3.61	0.06	0.00				
75.05	3.61	0.06	0.00				
77.55	3.61	0.06	0.00				
80.05	3.61	0.06	0.00				
82.55	3.61	0.06	0.00				
85.05	3.61	0.06	0.00				
87.55	3.61	0.06	0.00				
90.05	3.61	0.06	0.00				
92.55	3.61	0.06	0.00				
95.05	3.61	0.06	0.00				
97.55	3.61	0.06	0.00				
100.05	3.61	0.06	0.00				
102.55	3.61	0.06	0.00				
105.05	3.61	0.06	0.00				
107.55	3.61	0.06	0.00				
110.05	3.61	0.06	0.00				
112.55	3.61	0.06	0.00				
115.05	3.61	0.06	0.00				
117.55	3.61	0.06	0.00				
120.05	3.61	0.06	0.00				
122.55	3.61	0.06	0.00				
125.05	3.61	0.06	0.00				
127.55	3.61	0.06	0.00				

Summary for Subcatchment 4: Area 4

Runoff = 81.16 cfs @ 12.23 hrs, Volume= 7.668 af, Depth= 1.51"

Runoff by SCS TR-20 method, UH=SCS, Weighted-CN, Time Span= 0.05-168.00 hrs, dt= 0.05 hrs
 Type II 24-hr 10-yr Rainfall=3.61"

Area (ac)	CN	Description
60.300	77	Newly graded area, HSG A
0.530	98	Water Surface, HSG A
60.830	77	Weighted Average
60.300		99.13% Pervious Area
0.530		0.87% Impervious Area

Tc (min)	Length (feet)	Slope (ft/ft)	Velocity (ft/sec)	Capacity (cfs)	Description
7.9	100	0.0500	0.21		Sheet Flow, Grass: Short n= 0.150 P2= 2.35"
20.2	2,250	0.0700	1.85		Shallow Concentrated Flow, Short Grass Pasture Kv= 7.0 fps
28.1	2,350	Total			

Subcatchment 4: Area 4

Hydrograph

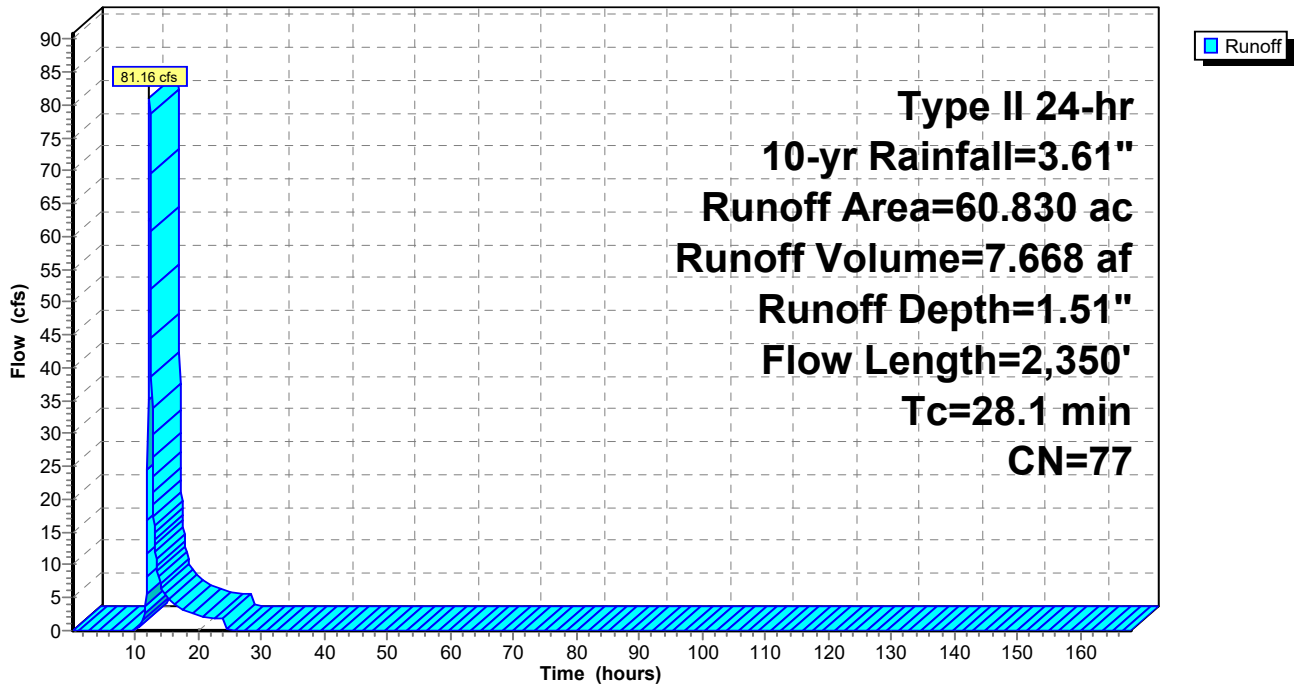

Hydrograph for Subcatchment 4: Area 4

Time (hours)	Precip. (inches)	Excess (inches)	Runoff (cfs)	Time (hours)	Precip. (inches)	Excess (inches)	Runoff (cfs)
0.05	0.00	0.00	0.00	130.05	3.61	1.51	0.00
2.55	0.10	0.00	0.00	132.55	3.61	1.51	0.00
5.05	0.23	0.00	0.00	135.05	3.61	1.51	0.00
7.55	0.40	0.00	0.00	137.55	3.61	1.51	0.00
10.05	0.66	0.00	0.07	140.05	3.61	1.51	0.00
12.55	2.67	0.85	38.63	142.55	3.61	1.51	0.00
15.05	3.09	1.13	5.05	145.05	3.61	1.51	0.00
17.55	3.29	1.28	3.23	147.55	3.61	1.51	0.00
20.05	3.44	1.39	2.27	150.05	3.61	1.51	0.00
22.55	3.55	1.47	1.97	152.55	3.61	1.51	0.00
25.05	3.61	1.51	0.03	155.05	3.61	1.51	0.00
27.55	3.61	1.51	0.00	157.55	3.61	1.51	0.00
30.05	3.61	1.51	0.00	160.05	3.61	1.51	0.00
32.55	3.61	1.51	0.00	162.55	3.61	1.51	0.00
35.05	3.61	1.51	0.00	165.05	3.61	1.51	0.00
37.55	3.61	1.51	0.00	167.55	3.61	1.51	0.00
40.05	3.61	1.51	0.00				
42.55	3.61	1.51	0.00				
45.05	3.61	1.51	0.00				
47.55	3.61	1.51	0.00				
50.05	3.61	1.51	0.00				
52.55	3.61	1.51	0.00				
55.05	3.61	1.51	0.00				
57.55	3.61	1.51	0.00				
60.05	3.61	1.51	0.00				
62.55	3.61	1.51	0.00				
65.05	3.61	1.51	0.00				
67.55	3.61	1.51	0.00				
70.05	3.61	1.51	0.00				
72.55	3.61	1.51	0.00				
75.05	3.61	1.51	0.00				
77.55	3.61	1.51	0.00				
80.05	3.61	1.51	0.00				
82.55	3.61	1.51	0.00				
85.05	3.61	1.51	0.00				
87.55	3.61	1.51	0.00				
90.05	3.61	1.51	0.00				
92.55	3.61	1.51	0.00				
95.05	3.61	1.51	0.00				
97.55	3.61	1.51	0.00				
100.05	3.61	1.51	0.00				
102.55	3.61	1.51	0.00				
105.05	3.61	1.51	0.00				
107.55	3.61	1.51	0.00				
110.05	3.61	1.51	0.00				
112.55	3.61	1.51	0.00				
115.05	3.61	1.51	0.00				
117.55	3.61	1.51	0.00				
120.05	3.61	1.51	0.00				
122.55	3.61	1.51	0.00				
125.05	3.61	1.51	0.00				
127.55	3.61	1.51	0.00				

Summary for Subcatchment 8: Downslope Area

Runoff = 35.51 cfs @ 12.11 hrs, Volume= 2.636 af, Depth= 1.13"

Runoff by SCS TR-20 method, UH=SCS, Weighted-CN, Time Span= 0.05-168.00 hrs, dt= 0.05 hrs
Type II 24-hr 10-yr Rainfall=3.61"

Area (sf)	CN	Description
138,897	32	Woods/grass comb., Good, HSG A
164,655	58	Woods/grass comb., Good, HSG B
33,867	85	Gravel roads, HSG B
877,297	79	Woods/grass comb., Good, HSG D
1,214,716	71	Weighted Average
1,214,716		100.00% Pervious Area

Tc (min)	Length (feet)	Slope (ft/ft)	Velocity (ft/sec)	Capacity (cfs)	Description
11.2	100	0.1500	0.15		Sheet Flow, Woods: Light underbrush n= 0.400 P2= 2.35"
6.5	750	0.1460	1.91		Shallow Concentrated Flow, Woodland Kv= 5.0 fps
17.7	850	Total			

Subcatchment 8: Downslope Area

Hydrograph

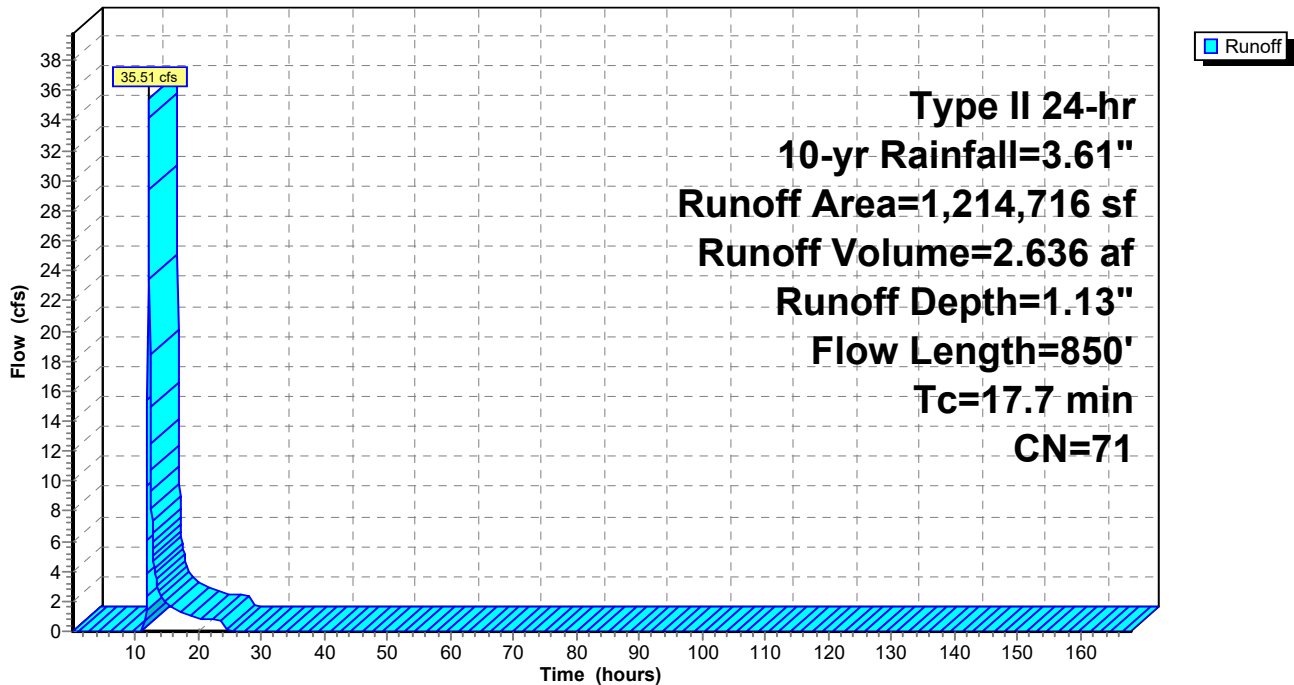

Hydrograph for Subcatchment 8: Downslope Area

Time (hours)	Precip. (inches)	Excess (inches)	Runoff (cfs)	Time (hours)	Precip. (inches)	Excess (inches)	Runoff (cfs)
0.05	0.00	0.00	0.00	130.05	3.61	1.13	0.00
2.55	0.10	0.00	0.00	132.55	3.61	1.13	0.00
5.05	0.23	0.00	0.00	135.05	3.61	1.13	0.00
7.55	0.40	0.00	0.00	137.55	3.61	1.13	0.00
10.05	0.66	0.00	0.00	140.05	3.61	1.13	0.00
12.55	2.67	0.58	8.21	142.55	3.61	1.13	0.00
15.05	3.09	0.81	1.87	145.05	3.61	1.13	0.00
17.55	3.29	0.94	1.23	147.55	3.61	1.13	0.00
20.05	3.44	1.03	0.86	150.05	3.61	1.13	0.00
22.55	3.55	1.10	0.77	152.55	3.61	1.13	0.00
25.05	3.61	1.13	0.00	155.05	3.61	1.13	0.00
27.55	3.61	1.13	0.00	157.55	3.61	1.13	0.00
30.05	3.61	1.13	0.00	160.05	3.61	1.13	0.00
32.55	3.61	1.13	0.00	162.55	3.61	1.13	0.00
35.05	3.61	1.13	0.00	165.05	3.61	1.13	0.00
37.55	3.61	1.13	0.00	167.55	3.61	1.13	0.00
40.05	3.61	1.13	0.00				
42.55	3.61	1.13	0.00				
45.05	3.61	1.13	0.00				
47.55	3.61	1.13	0.00				
50.05	3.61	1.13	0.00				
52.55	3.61	1.13	0.00				
55.05	3.61	1.13	0.00				
57.55	3.61	1.13	0.00				
60.05	3.61	1.13	0.00				
62.55	3.61	1.13	0.00				
65.05	3.61	1.13	0.00				
67.55	3.61	1.13	0.00				
70.05	3.61	1.13	0.00				
72.55	3.61	1.13	0.00				
75.05	3.61	1.13	0.00				
77.55	3.61	1.13	0.00				
80.05	3.61	1.13	0.00				
82.55	3.61	1.13	0.00				
85.05	3.61	1.13	0.00				
87.55	3.61	1.13	0.00				
90.05	3.61	1.13	0.00				
92.55	3.61	1.13	0.00				
95.05	3.61	1.13	0.00				
97.55	3.61	1.13	0.00				
100.05	3.61	1.13	0.00				
102.55	3.61	1.13	0.00				
105.05	3.61	1.13	0.00				
107.55	3.61	1.13	0.00				
110.05	3.61	1.13	0.00				
112.55	3.61	1.13	0.00				
115.05	3.61	1.13	0.00				
117.55	3.61	1.13	0.00				
120.05	3.61	1.13	0.00				
122.55	3.61	1.13	0.00				
125.05	3.61	1.13	0.00				
127.55	3.61	1.13	0.00				

Summary for Reach R1: Drainage Easement

Inflow Area = 88.716 ac, 0.60% Impervious, Inflow Depth = 1.39" for 10-yr event
 Inflow = 36.69 cfs @ 12.12 hrs, Volume= 10.304 af
 Outflow = 32.87 cfs @ 12.27 hrs, Volume= 10.304 af, Atten= 10%, Lag= 9.1 min

Routing by Stor-Ind+Trans method, Time Span= 0.05-168.00 hrs, dt= 0.05 hrs
 Max. Velocity= 6.15 fps, Min. Travel Time= 5.1 min
 Avg. Velocity = 1.60 fps, Avg. Travel Time= 19.7 min

Peak Storage= 10,157 cf @ 12.18 hrs
 Average Depth at Peak Storage= 1.76'
 Bank-Full Depth= 3.00' Flow Area= 12.0 sf, Capacity= 97.49 cfs

6.00' x 3.00' deep Parabolic Channel, n= 0.030 Earth, grassed & winding
 Length= 1,890.0' Slope= 0.0180 '/'
 Inlet Invert= 780.00', Outlet Invert= 746.00'

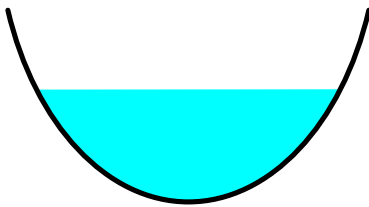

Reach R1: Drainage Easement

Hydrograph

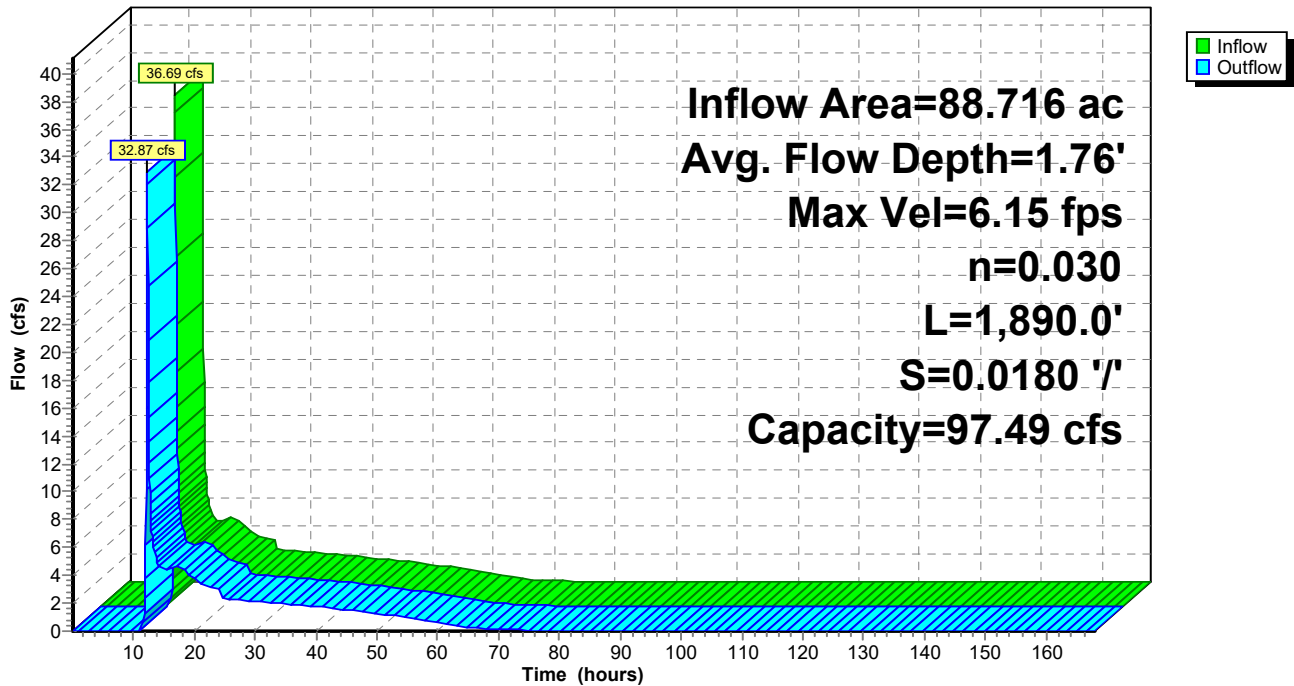

Reach R1: Drainage Easement

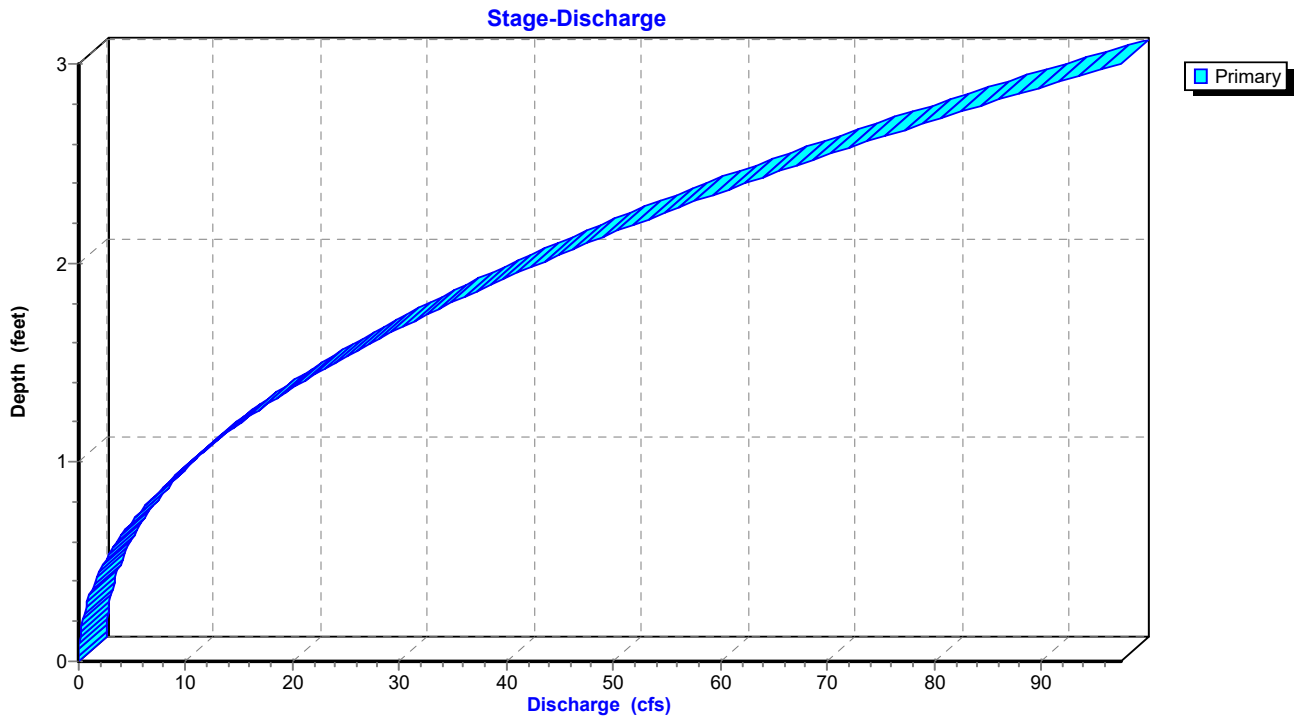

Reach R1: Drainage Easement

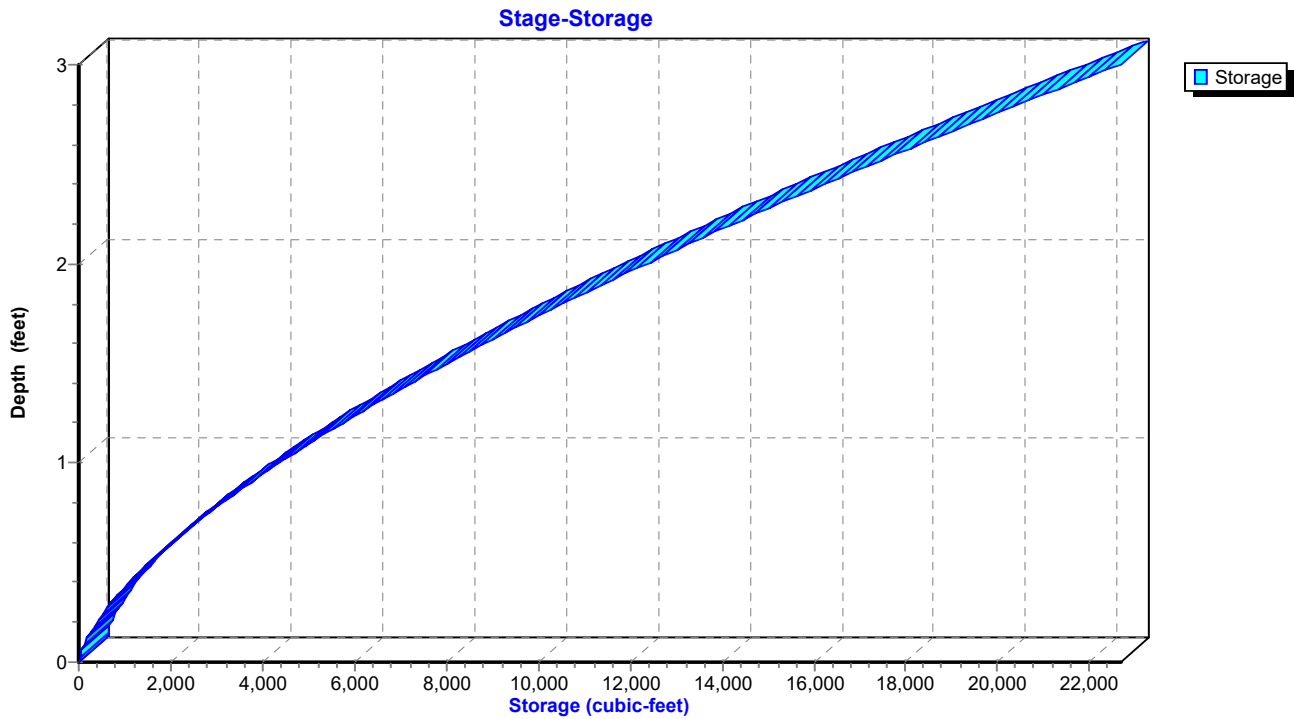

IGN Padua Ridge Pre-Reclaimed v2 sharp weir

Type II 24-hr 10-yr Rainfall=3.61"

Prepared by JMT

Printed 1/31/2022

HydroCAD® 10.00-20 s/n 02102 © 2017 HydroCAD Software Solutions LLC

Page 17

Hydrograph for Reach R1: Drainage Easement

Time (hours)	Inflow (cfs)	Storage (cubic-feet)	Elevation (feet)	Outflow (cfs)
0.05	0.00	0	780.00	0.00
5.05	0.00	0	780.00	0.00
10.05	0.00	0	780.00	0.00
15.05	4.19	2,280	780.65	4.26
20.05	3.65	2,073	780.61	3.74
25.05	2.30	1,479	780.49	2.31
30.05	2.13	1,399	780.47	2.13
35.05	1.94	1,311	780.45	1.95
40.05	1.73	1,210	780.43	1.74
45.05	1.50	1,093	780.40	1.51
50.05	1.23	954	780.36	1.25
55.05	0.94	790	780.32	0.96
60.05	0.62	596	780.27	0.64
65.05	0.26	335	780.18	0.29
70.05	0.09	159	780.11	0.10
75.05	0.05	101	780.08	0.05
80.05	0.03	65	780.06	0.03
85.05	0.01	40	780.04	0.01
90.05	0.01	26	780.03	0.01
95.05	0.00	16	780.02	0.00
100.05	0.00	8	780.01	0.00
105.05	0.00	4	780.01	0.00
110.05	0.00	2	780.00	0.00
115.05	0.00	1	780.00	0.00
120.05	0.00	1	780.00	0.00
125.05	0.00	0	780.00	0.00
130.05	0.00	0	780.00	0.00
135.05	0.00	0	780.00	0.00
140.05	0.00	0	780.00	0.00
145.05	0.00	0	780.00	0.00
150.05	0.00	0	780.00	0.00
155.05	0.00	0	780.00	0.00
160.05	0.00	0	780.00	0.00
165.05	0.00	0	780.00	0.00

Stage-Discharge for Reach R1: Drainage Easement

Elevation (feet)	Velocity (ft/sec)	Discharge (cfs)	Elevation (feet)	Velocity (ft/sec)	Discharge (cfs)	Elevation (feet)	Velocity (ft/sec)	Discharge (cfs)
780.00	0.00	0.00	781.04	4.61	11.31	782.08	6.74	46.71
780.02	0.32	0.00	781.06	4.66	11.76	782.10	6.78	47.62
780.04	0.58	0.01	781.08	4.71	12.22	782.12	6.81	48.54
780.06	0.77	0.03	781.10	4.76	12.70	782.14	6.84	49.47
780.08	0.93	0.05	781.12	4.81	13.18	782.16	6.88	50.41
780.10	1.07	0.08	781.14	4.86	13.66	782.18	6.91	51.36
780.12	1.21	0.12	781.16	4.91	14.17	782.20	6.94	52.31
780.14	1.34	0.16	781.18	4.96	14.67	782.22	6.97	53.28
780.16	1.46	0.22	781.20	5.00	15.19	782.24	7.01	54.25
780.18	1.58	0.28	781.22	5.05	15.72	782.26	7.04	55.23
780.20	1.69	0.35	781.24	5.10	16.25	782.28	7.07	56.22
780.22	1.79	0.43	781.26	5.14	16.80	782.30	7.10	57.22
780.24	1.89	0.51	781.28	5.19	17.35	782.32	7.13	58.23
780.26	1.99	0.61	781.30	5.23	17.91	782.34	7.17	59.24
780.28	2.09	0.72	781.32	5.28	18.48	782.36	7.20	60.27
780.30	2.18	0.83	781.34	5.32	19.06	782.38	7.23	61.30
780.32	2.27	0.95	781.36	5.36	19.65	782.40	7.26	62.34
780.34	2.36	1.08	781.38	5.41	20.25	782.42	7.29	63.39
780.36	2.44	1.22	781.40	5.45	20.86	782.44	7.32	64.45
780.38	2.53	1.37	781.42	5.49	21.47	782.46	7.35	65.51
780.40	2.61	1.53	781.44	5.54	22.09	782.48	7.38	66.59
780.42	2.69	1.69	781.46	5.58	22.73	782.50	7.41	67.67
780.44	2.77	1.87	781.48	5.62	23.37	782.52	7.44	68.76
780.46	2.84	2.05	781.50	5.66	24.02	782.54	7.47	69.87
780.48	2.92	2.24	781.52	5.70	24.68	782.56	7.50	70.97
780.50	2.99	2.45	781.54	5.74	25.35	782.58	7.53	72.09
780.52	3.07	2.66	781.56	5.78	26.02	782.60	7.56	73.22
780.54	3.14	2.87	781.58	5.82	26.71	782.62	7.59	74.35
780.56	3.21	3.11	781.60	5.86	27.41	782.64	7.62	75.49
780.58	3.28	3.34	781.62	5.90	28.11	782.66	7.65	76.65
780.60	3.34	3.59	781.64	5.94	28.82	782.68	7.68	77.80
780.62	3.41	3.85	781.66	5.98	29.54	782.70	7.71	78.97
780.64	3.47	4.11	781.68	6.02	30.27	782.72	7.74	80.15
780.66	3.54	4.38	781.70	6.06	31.01	782.74	7.76	81.33
780.68	3.60	4.67	781.72	6.10	31.76	782.76	7.79	82.52
780.70	3.66	4.96	781.74	6.13	32.52	782.78	7.82	83.73
780.72	3.73	5.26	781.76	6.17	33.28	782.80	7.85	84.94
780.74	3.79	5.57	781.78	6.21	34.06	782.82	7.88	86.15
780.76	3.85	5.89	781.80	6.25	34.84	782.84	7.91	87.38
780.78	3.91	6.22	781.82	6.28	35.63	782.86	7.93	88.62
780.80	3.97	6.55	781.84	6.32	36.43	782.88	7.96	89.86
780.82	4.02	6.90	781.86	6.36	37.24	782.90	7.99	91.11
780.84	4.08	7.25	781.88	6.39	38.06	782.92	8.02	92.37
780.86	4.14	7.62	781.90	6.43	38.88	782.94	8.04	93.64
780.88	4.19	7.99	781.92	6.46	39.72	782.96	8.07	94.92
780.90	4.25	8.37	781.94	6.50	40.56	782.98	8.10	96.20
780.92	4.30	8.77	781.96	6.53	41.41	783.00	8.12	97.49
780.94	4.35	9.17	781.98	6.57	42.27			
780.96	4.41	9.58	782.00	6.60	43.14			
780.98	4.46	10.00	782.02	6.64	44.02			
781.00	4.51	10.42	782.04	6.67	44.91			
781.02	4.56	10.86	782.06	6.71	45.80			

Stage-Area-Storage for Reach R1: Drainage Easement

Elevation (feet)	End-Area (sq-ft)	Storage (cubic-feet)	Elevation (feet)	End-Area (sq-ft)	Storage (cubic-feet)
780.00	0.0	0	782.60	9.7	18,299
780.05	0.0	50	782.65	10.0	18,829
780.10	0.1	139	782.70	10.2	19,365
780.15	0.1	254	782.75	10.5	19,905
780.20	0.2	391	782.80	10.8	20,450
780.25	0.3	546	782.85	11.1	21,000
780.30	0.4	717	782.90	11.4	21,556
780.35	0.5	904	782.95	11.7	22,116
780.40	0.6	1,105	783.00	12.0	22,680
780.45	0.7	1,318			
780.50	0.8	1,544			
780.55	0.9	1,781			
780.60	1.1	2,029			
780.65	1.2	2,288			
780.70	1.4	2,557			
780.75	1.5	2,835			
780.80	1.7	3,124			
780.85	1.8	3,421			
780.90	2.0	3,727			
780.95	2.1	4,042			
781.00	2.3	4,365			
781.05	2.5	4,696			
781.10	2.7	5,036			
781.15	2.8	5,383			
781.20	3.0	5,738			
781.25	3.2	6,100			
781.30	3.4	6,470			
781.35	3.6	6,846			
781.40	3.8	7,231			
781.45	4.0	7,621			
781.50	4.2	8,019			
781.55	4.5	8,423			
781.60	4.7	8,834			
781.65	4.9	9,251			
781.70	5.1	9,675			
781.75	5.3	10,105			
781.80	5.6	10,541			
781.85	5.8	10,983			
781.90	6.0	11,431			
781.95	6.3	11,885			
782.00	6.5	12,346			
782.05	6.8	12,811			
782.10	7.0	13,283			
782.15	7.3	13,760			
782.20	7.5	14,243			
782.25	7.8	14,731			
782.30	8.1	15,225			
782.35	8.3	15,724			
782.40	8.6	16,228			
782.45	8.9	16,738			
782.50	9.1	17,253			
782.55	9.4	17,773			

Summary for Pond P1: Infiltration Area

Inflow Area = 6.411 ac, 0.00% Impervious, Inflow Depth = 0.42" for 10-yr event
 Inflow = 2.51 cfs @ 12.07 hrs, Volume= 0.224 af
 Outflow = 0.13 cfs @ 18.47 hrs, Volume= 0.224 af, Atten= 95%, Lag= 383.8 min
 Discarded = 0.13 cfs @ 18.47 hrs, Volume= 0.224 af

Routing by Stor-Ind method, Time Span= 0.05-168.00 hrs, dt= 0.05 hrs
 Peak Elev= 855.39' @ 18.47 hrs Surf.Area= 11,337 sf Storage= 4,446 cf

Plug-Flow detention time= 394.5 min calculated for 0.224 af (100% of inflow)
 Center-of-Mass det. time= 394.4 min (1,325.1 - 930.7)

Volume	Invert	Avail.Storage	Storage Description
#1	855.00'	22,674 cf	Custom Stage Data (Prismatic) Listed below (Recalc)

Elevation (feet)	Surf.Area (sq-ft)	Inc.Store (cubic-feet)	Cum.Store (cubic-feet)
855.00	11,337	0	0
856.00	11,337	11,337	11,337
857.00	11,337	11,337	22,674

Device	Routing	Invert	Outlet Devices
#1	Discarded	855.00'	0.500 in/hr Exfiltration over Surface area Conductivity to Groundwater Elevation = 840.00'

Discarded OutFlow Max=0.13 cfs @ 18.47 hrs HW=855.39' (Free Discharge)

↑**1=Exfiltration** (Controls 0.13 cfs)

Pond P1: Infiltration Area

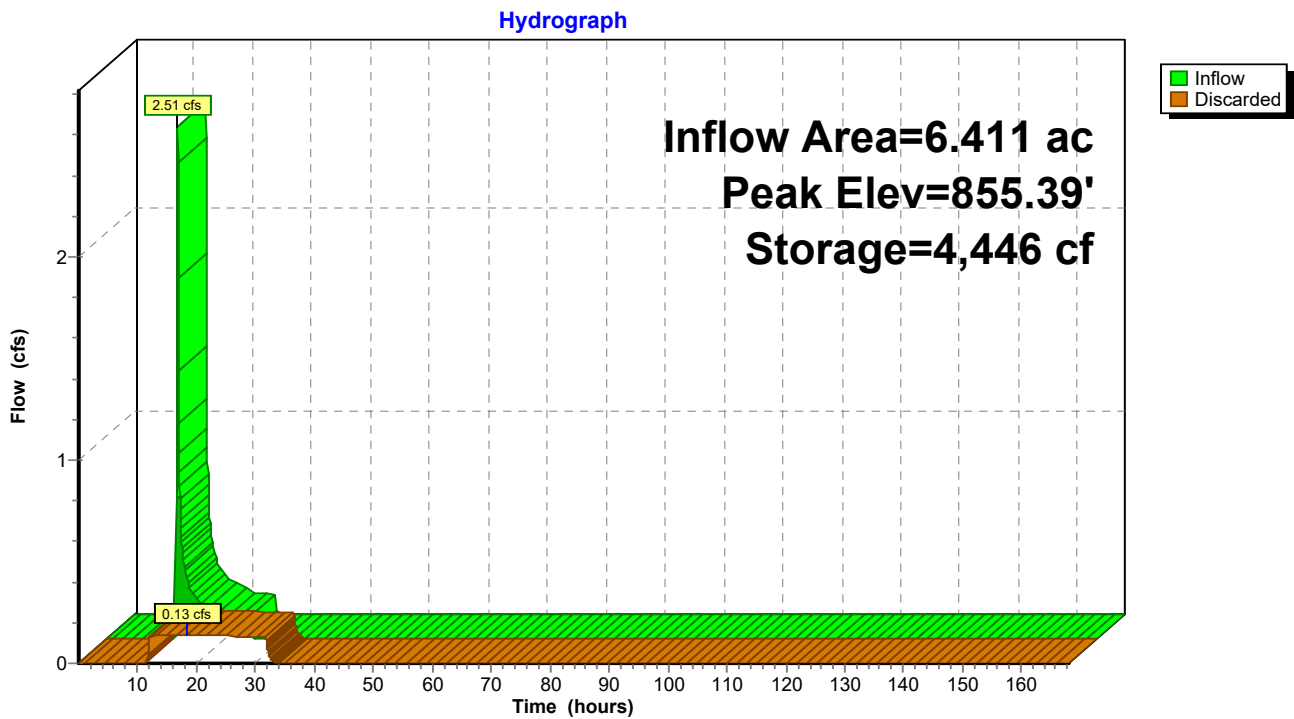

Pond P1: Infiltration Area

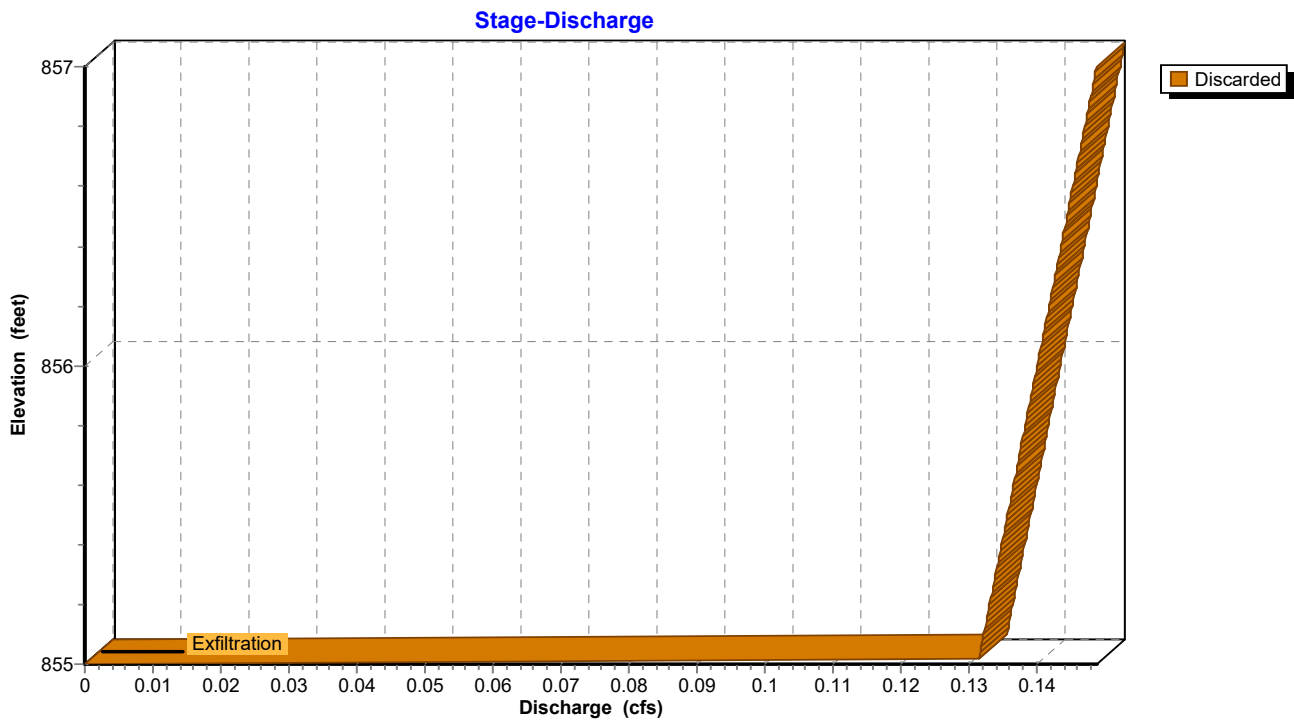

Pond P1: Infiltration Area

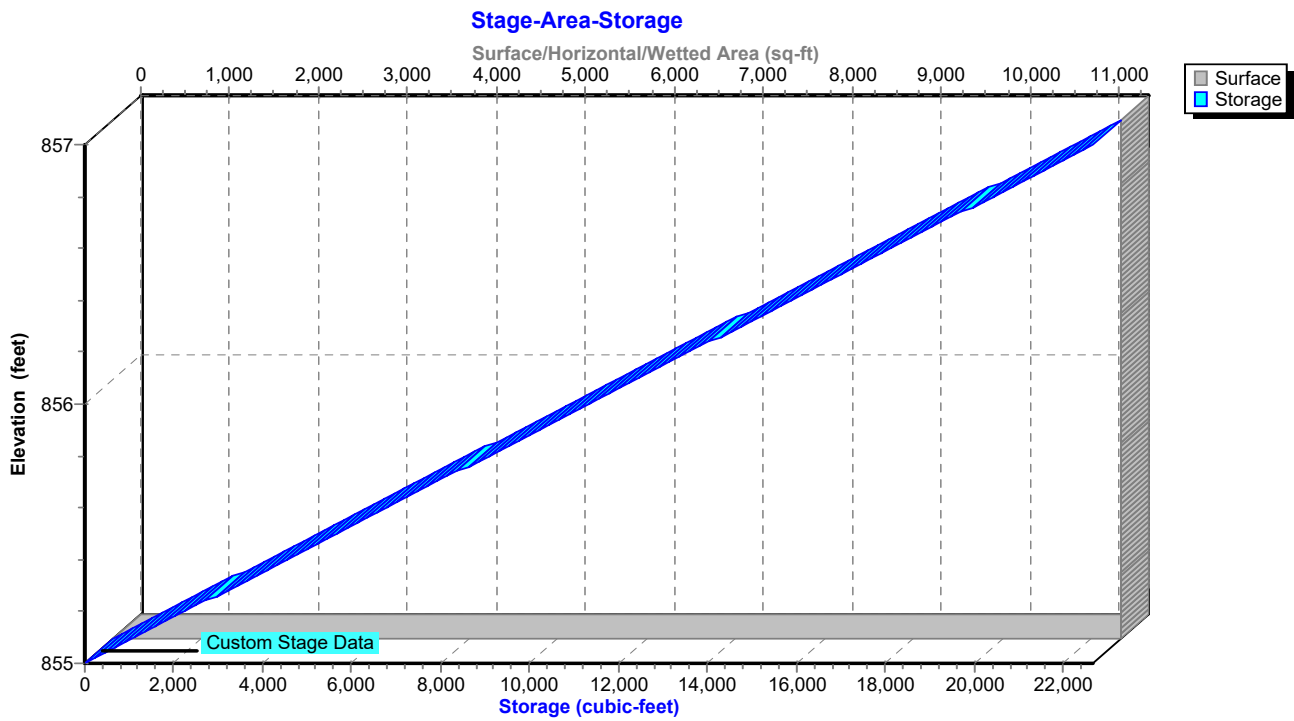

IGN Padua Ridge Pre-Reclaimed v2 sharp weir

Type II 24-hr 10-yr Rainfall=3.61"

Prepared by JMT

Printed 1/31/2022

HydroCAD® 10.00-20 s/n 02102 © 2017 HydroCAD Software Solutions LLC

Page 23

Hydrograph for Pond P1: Infiltration Area

Time (hours)	Inflow (cfs)	Storage (cubic-feet)	Elevation (feet)	Discarded (cfs)
0.05	0.00	0	855.00	0.00
5.05	0.00	0	855.00	0.00
10.05	0.00	0	855.00	0.00
15.05	0.21	4,081	855.36	0.13
20.05	0.11	4,370	855.39	0.13
25.05	0.00	3,443	855.30	0.13
30.05	0.00	1,050	855.09	0.13
35.05	0.00	0	855.00	0.00
40.05	0.00	0	855.00	0.00
45.05	0.00	0	855.00	0.00
50.05	0.00	0	855.00	0.00
55.05	0.00	0	855.00	0.00
60.05	0.00	0	855.00	0.00
65.05	0.00	0	855.00	0.00
70.05	0.00	0	855.00	0.00
75.05	0.00	0	855.00	0.00
80.05	0.00	0	855.00	0.00
85.05	0.00	0	855.00	0.00
90.05	0.00	0	855.00	0.00
95.05	0.00	0	855.00	0.00
100.05	0.00	0	855.00	0.00
105.05	0.00	0	855.00	0.00
110.05	0.00	0	855.00	0.00
115.05	0.00	0	855.00	0.00
120.05	0.00	0	855.00	0.00
125.05	0.00	0	855.00	0.00
130.05	0.00	0	855.00	0.00
135.05	0.00	0	855.00	0.00
140.05	0.00	0	855.00	0.00
145.05	0.00	0	855.00	0.00
150.05	0.00	0	855.00	0.00
155.05	0.00	0	855.00	0.00
160.05	0.00	0	855.00	0.00
165.05	0.00	0	855.00	0.00

Stage-Discharge for Pond P1: Infiltration Area

Elevation (feet)	Discarded (cfs)	Elevation (feet)	Discarded (cfs)	Elevation (feet)	Discarded (cfs)	Elevation (feet)	Discarded (cfs)
855.00	0.00	855.52	0.14	856.04	0.14	856.56	0.14
855.01	0.13	855.53	0.14	856.05	0.14	856.57	0.14
855.02	0.13	855.54	0.14	856.06	0.14	856.58	0.15
855.03	0.13	855.55	0.14	856.07	0.14	856.59	0.15
855.04	0.13	855.56	0.14	856.08	0.14	856.60	0.15
855.05	0.13	855.57	0.14	856.09	0.14	856.61	0.15
855.06	0.13	855.58	0.14	856.10	0.14	856.62	0.15
855.07	0.13	855.59	0.14	856.11	0.14	856.63	0.15
855.08	0.13	855.60	0.14	856.12	0.14	856.64	0.15
855.09	0.13	855.61	0.14	856.13	0.14	856.65	0.15
855.10	0.13	855.62	0.14	856.14	0.14	856.66	0.15
855.11	0.13	855.63	0.14	856.15	0.14	856.67	0.15
855.12	0.13	855.64	0.14	856.16	0.14	856.68	0.15
855.13	0.13	855.65	0.14	856.17	0.14	856.69	0.15
855.14	0.13	855.66	0.14	856.18	0.14	856.70	0.15
855.15	0.13	855.67	0.14	856.19	0.14	856.71	0.15
855.16	0.13	855.68	0.14	856.20	0.14	856.72	0.15
855.17	0.13	855.69	0.14	856.21	0.14	856.73	0.15
855.18	0.13	855.70	0.14	856.22	0.14	856.74	0.15
855.19	0.13	855.71	0.14	856.23	0.14	856.75	0.15
855.20	0.13	855.72	0.14	856.24	0.14	856.76	0.15
855.21	0.13	855.73	0.14	856.25	0.14	856.77	0.15
855.22	0.13	855.74	0.14	856.26	0.14	856.78	0.15
855.23	0.13	855.75	0.14	856.27	0.14	856.79	0.15
855.24	0.13	855.76	0.14	856.28	0.14	856.80	0.15
855.25	0.13	855.77	0.14	856.29	0.14	856.81	0.15
855.26	0.13	855.78	0.14	856.30	0.14	856.82	0.15
855.27	0.13	855.79	0.14	856.31	0.14	856.83	0.15
855.28	0.13	855.80	0.14	856.32	0.14	856.84	0.15
855.29	0.13	855.81	0.14	856.33	0.14	856.85	0.15
855.30	0.13	855.82	0.14	856.34	0.14	856.86	0.15
855.31	0.13	855.83	0.14	856.35	0.14	856.87	0.15
855.32	0.13	855.84	0.14	856.36	0.14	856.88	0.15
855.33	0.13	855.85	0.14	856.37	0.14	856.89	0.15
855.34	0.13	855.86	0.14	856.38	0.14	856.90	0.15
855.35	0.13	855.87	0.14	856.39	0.14	856.91	0.15
855.36	0.13	855.88	0.14	856.40	0.14	856.92	0.15
855.37	0.13	855.89	0.14	856.41	0.14	856.93	0.15
855.38	0.13	855.90	0.14	856.42	0.14	856.94	0.15
855.39	0.13	855.91	0.14	856.43	0.14	856.95	0.15
855.40	0.13	855.92	0.14	856.44	0.14	856.96	0.15
855.41	0.13	855.93	0.14	856.45	0.14	856.97	0.15
855.42	0.13	855.94	0.14	856.46	0.14	856.98	0.15
855.43	0.13	855.95	0.14	856.47	0.14	856.99	0.15
855.44	0.14	855.96	0.14	856.48	0.14	857.00	0.15
855.45	0.14	855.97	0.14	856.49	0.14		
855.46	0.14	855.98	0.14	856.50	0.14		
855.47	0.14	855.99	0.14	856.51	0.14		
855.48	0.14	856.00	0.14	856.52	0.14		
855.49	0.14	856.01	0.14	856.53	0.14		
855.50	0.14	856.02	0.14	856.54	0.14		
855.51	0.14	856.03	0.14	856.55	0.14		

Stage-Area-Storage for Pond P1: Infiltration Area

Elevation (feet)	Surface (sq-ft)	Storage (cubic-feet)	Elevation (feet)	Surface (sq-ft)	Storage (cubic-feet)
855.00	11,337	0	856.04	11,337	11,790
855.02	11,337	227	856.06	11,337	12,017
855.04	11,337	453	856.08	11,337	12,244
855.06	11,337	680	856.10	11,337	12,471
855.08	11,337	907	856.12	11,337	12,697
855.10	11,337	1,134	856.14	11,337	12,924
855.12	11,337	1,360	856.16	11,337	13,151
855.14	11,337	1,587	856.18	11,337	13,378
855.16	11,337	1,814	856.20	11,337	13,604
855.18	11,337	2,041	856.22	11,337	13,831
855.20	11,337	2,267	856.24	11,337	14,058
855.22	11,337	2,494	856.26	11,337	14,285
855.24	11,337	2,721	856.28	11,337	14,511
855.26	11,337	2,948	856.30	11,337	14,738
855.28	11,337	3,174	856.32	11,337	14,965
855.30	11,337	3,401	856.34	11,337	15,192
855.32	11,337	3,628	856.36	11,337	15,418
855.34	11,337	3,855	856.38	11,337	15,645
855.36	11,337	4,081	856.40	11,337	15,872
855.38	11,337	4,308	856.42	11,337	16,099
855.40	11,337	4,535	856.44	11,337	16,325
855.42	11,337	4,762	856.46	11,337	16,552
855.44	11,337	4,988	856.48	11,337	16,779
855.46	11,337	5,215	856.50	11,337	17,006
855.48	11,337	5,442	856.52	11,337	17,232
855.50	11,337	5,669	856.54	11,337	17,459
855.52	11,337	5,895	856.56	11,337	17,686
855.54	11,337	6,122	856.58	11,337	17,912
855.56	11,337	6,349	856.60	11,337	18,139
855.58	11,337	6,575	856.62	11,337	18,366
855.60	11,337	6,802	856.64	11,337	18,593
855.62	11,337	7,029	856.66	11,337	18,819
855.64	11,337	7,256	856.68	11,337	19,046
855.66	11,337	7,482	856.70	11,337	19,273
855.68	11,337	7,709	856.72	11,337	19,500
855.70	11,337	7,936	856.74	11,337	19,726
855.72	11,337	8,163	856.76	11,337	19,953
855.74	11,337	8,389	856.78	11,337	20,180
855.76	11,337	8,616	856.80	11,337	20,407
855.78	11,337	8,843	856.82	11,337	20,633
855.80	11,337	9,070	856.84	11,337	20,860
855.82	11,337	9,296	856.86	11,337	21,087
855.84	11,337	9,523	856.88	11,337	21,314
855.86	11,337	9,750	856.90	11,337	21,540
855.88	11,337	9,977	856.92	11,337	21,767
855.90	11,337	10,203	856.94	11,337	21,994
855.92	11,337	10,430	856.96	11,337	22,221
855.94	11,337	10,657	856.98	11,337	22,447
855.96	11,337	10,884	857.00	11,337	22,674
855.98	11,337	11,110			
856.00	11,337	11,337			
856.02	11,337	11,564			

Summary for Pond P3: Infiltration Area

Inflow Area = 5.511 ac, 0.00% Impervious, Inflow Depth = 0.06" for 10-yr event
 Inflow = 0.04 cfs @ 15.22 hrs, Volume= 0.030 af
 Outflow = 0.04 cfs @ 15.71 hrs, Volume= 0.030 af, Atten= 2%, Lag= 29.0 min
 Discarded = 0.04 cfs @ 15.71 hrs, Volume= 0.030 af

Routing by Stor-Ind method, Time Span= 0.05-168.00 hrs, dt= 0.05 hrs
 Peak Elev= 855.01' @ 15.71 hrs Surf.Area= 10,679 sf Storage= 63 cf

Plug-Flow detention time= 28.7 min calculated for 0.030 af (100% of inflow)
 Center-of-Mass det. time= 28.8 min (1,129.4 - 1,100.6)

Volume	Invert	Avail.Storage	Storage Description
#1	855.00'	21,358 cf	Custom Stage Data (Prismatic) Listed below (Recalc)
Elevation (feet)	Surf.Area (sq-ft)	Inc.Store (cubic-feet)	Cum.Store (cubic-feet)
855.00	10,679	0	0
856.00	10,679	10,679	10,679
857.00	10,679	10,679	21,358

Device	Routing	Invert	Outlet Devices
#1	Discarded	855.00'	0.500 in/hr Exfiltration over Surface area Conductivity to Groundwater Elevation = 840.00'

Discarded OutFlow Max=0.12 cfs @ 15.71 hrs HW=855.01' (Free Discharge)
 ↑**1=Exfiltration** (Controls 0.12 cfs)

Pond P3: Infiltration Area

Hydrograph

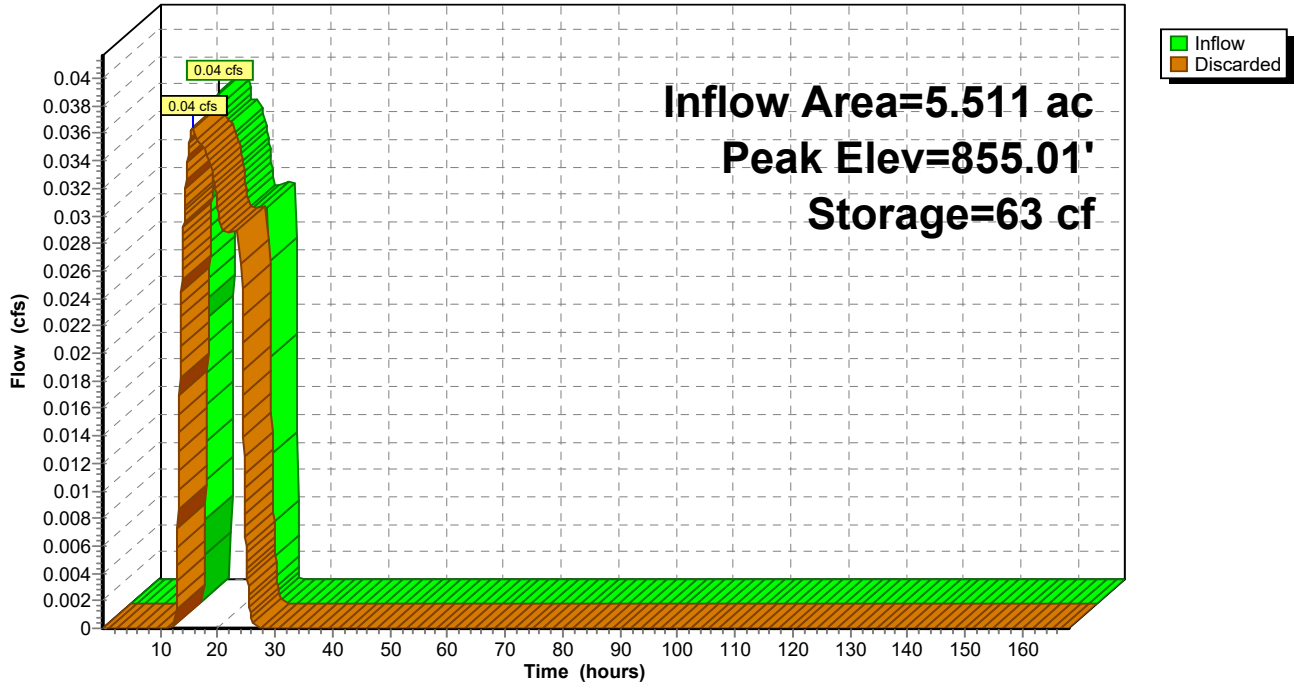

Pond P3: Infiltration Area

Stage-Discharge

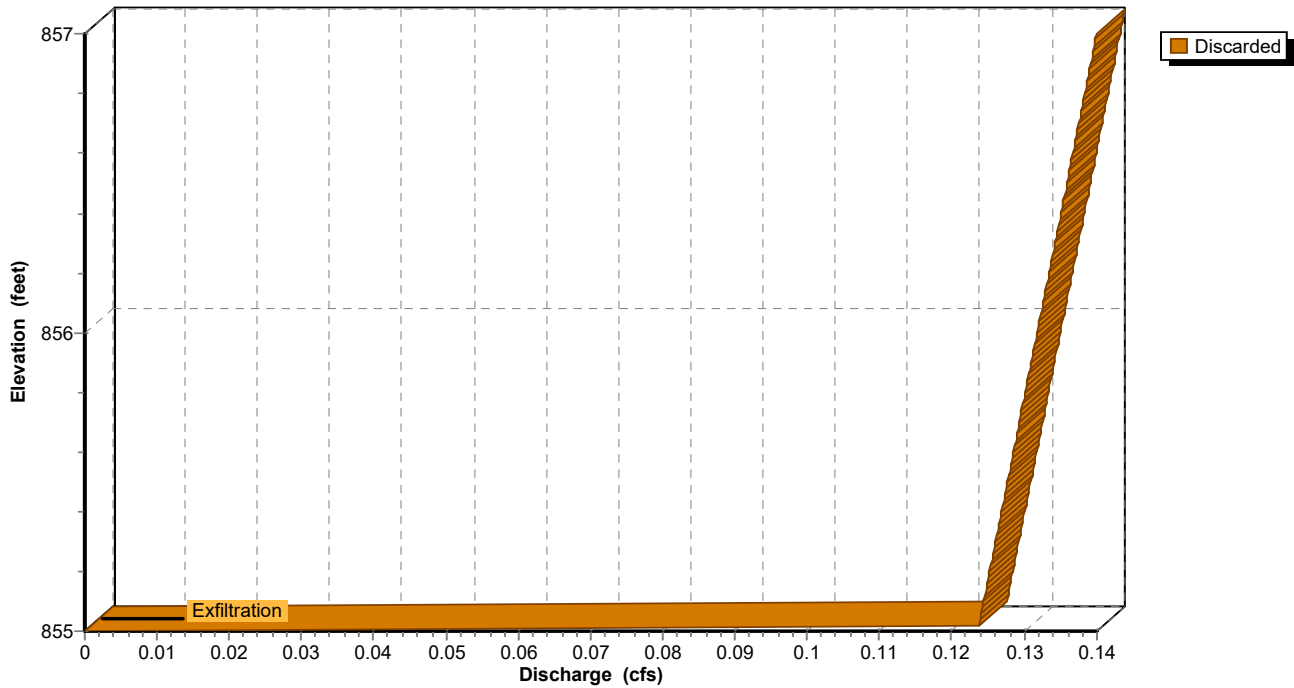

Pond P3: Infiltration Area

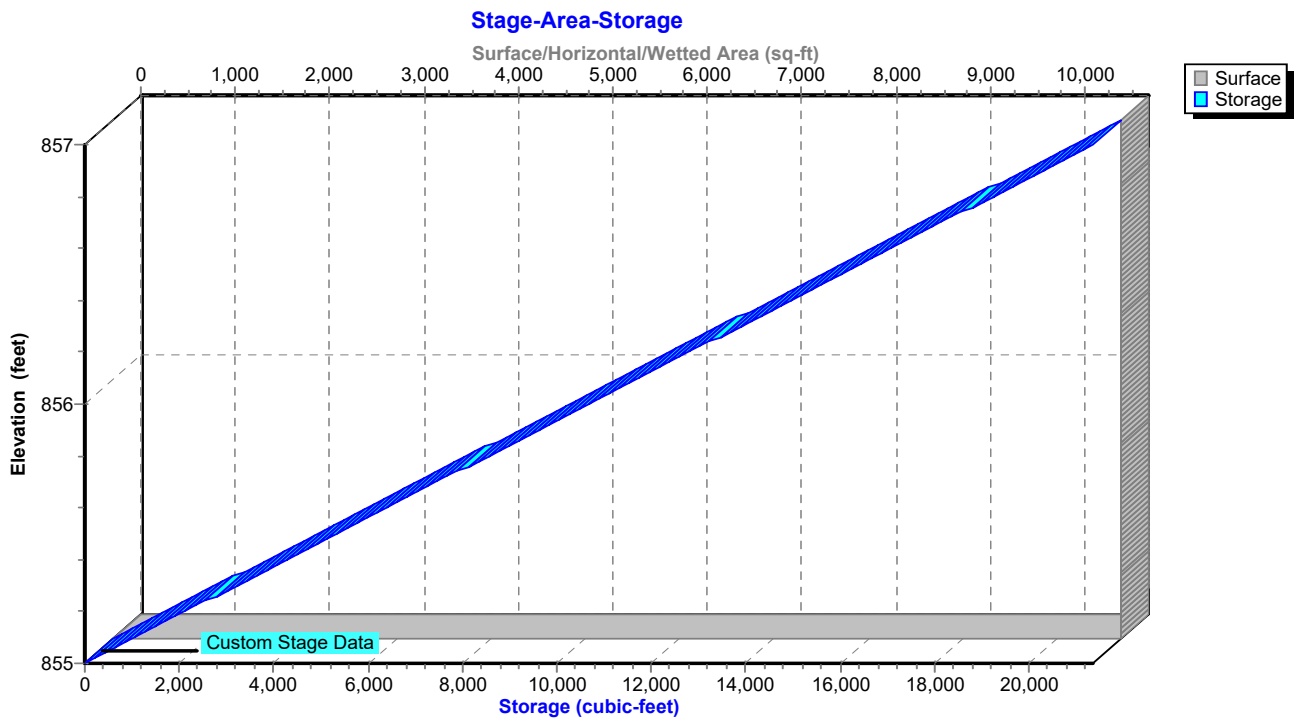

Hydrograph for Pond P3: Infiltration Area

Time (hours)	Inflow (cfs)	Storage (cubic-feet)	Elevation (feet)	Discarded (cfs)
0.05	0.00	0	855.00	0.00
5.05	0.00	0	855.00	0.00
10.05	0.00	0	855.00	0.00
15.05	0.04	61	855.01	0.04
20.05	0.03	53	855.00	0.03
25.05	0.00	8	855.00	0.00
30.05	0.00	0	855.00	0.00
35.05	0.00	0	855.00	0.00
40.05	0.00	0	855.00	0.00
45.05	0.00	0	855.00	0.00
50.05	0.00	0	855.00	0.00
55.05	0.00	0	855.00	0.00
60.05	0.00	0	855.00	0.00
65.05	0.00	0	855.00	0.00
70.05	0.00	0	855.00	0.00
75.05	0.00	0	855.00	0.00
80.05	0.00	0	855.00	0.00
85.05	0.00	0	855.00	0.00
90.05	0.00	0	855.00	0.00
95.05	0.00	0	855.00	0.00
100.05	0.00	0	855.00	0.00
105.05	0.00	0	855.00	0.00
110.05	0.00	0	855.00	0.00
115.05	0.00	0	855.00	0.00
120.05	0.00	0	855.00	0.00
125.05	0.00	0	855.00	0.00
130.05	0.00	0	855.00	0.00
135.05	0.00	0	855.00	0.00
140.05	0.00	0	855.00	0.00
145.05	0.00	0	855.00	0.00
150.05	0.00	0	855.00	0.00
155.05	0.00	0	855.00	0.00
160.05	0.00	0	855.00	0.00
165.05	0.00	0	855.00	0.00

Stage-Discharge for Pond P3: Infiltration Area

Elevation (feet)	Discarded (cfs)	Elevation (feet)	Discarded (cfs)	Elevation (feet)	Discarded (cfs)	Elevation (feet)	Discarded (cfs)
855.00	0.00	855.52	0.13	856.04	0.13	856.56	0.14
855.01	0.12	855.53	0.13	856.05	0.13	856.57	0.14
855.02	0.12	855.54	0.13	856.06	0.13	856.58	0.14
855.03	0.12	855.55	0.13	856.07	0.13	856.59	0.14
855.04	0.12	855.56	0.13	856.08	0.13	856.60	0.14
855.05	0.12	855.57	0.13	856.09	0.13	856.61	0.14
855.06	0.12	855.58	0.13	856.10	0.13	856.62	0.14
855.07	0.12	855.59	0.13	856.11	0.13	856.63	0.14
855.08	0.12	855.60	0.13	856.12	0.13	856.64	0.14
855.09	0.12	855.61	0.13	856.13	0.13	856.65	0.14
855.10	0.12	855.62	0.13	856.14	0.13	856.66	0.14
855.11	0.12	855.63	0.13	856.15	0.13	856.67	0.14
855.12	0.12	855.64	0.13	856.16	0.13	856.68	0.14
855.13	0.12	855.65	0.13	856.17	0.13	856.69	0.14
855.14	0.12	855.66	0.13	856.18	0.13	856.70	0.14
855.15	0.12	855.67	0.13	856.19	0.13	856.71	0.14
855.16	0.12	855.68	0.13	856.20	0.13	856.72	0.14
855.17	0.13	855.69	0.13	856.21	0.13	856.73	0.14
855.18	0.13	855.70	0.13	856.22	0.13	856.74	0.14
855.19	0.13	855.71	0.13	856.23	0.13	856.75	0.14
855.20	0.13	855.72	0.13	856.24	0.13	856.76	0.14
855.21	0.13	855.73	0.13	856.25	0.13	856.77	0.14
855.22	0.13	855.74	0.13	856.26	0.13	856.78	0.14
855.23	0.13	855.75	0.13	856.27	0.13	856.79	0.14
855.24	0.13	855.76	0.13	856.28	0.13	856.80	0.14
855.25	0.13	855.77	0.13	856.29	0.13	856.81	0.14
855.26	0.13	855.78	0.13	856.30	0.13	856.82	0.14
855.27	0.13	855.79	0.13	856.31	0.13	856.83	0.14
855.28	0.13	855.80	0.13	856.32	0.13	856.84	0.14
855.29	0.13	855.81	0.13	856.33	0.13	856.85	0.14
855.30	0.13	855.82	0.13	856.34	0.13	856.86	0.14
855.31	0.13	855.83	0.13	856.35	0.13	856.87	0.14
855.32	0.13	855.84	0.13	856.36	0.13	856.88	0.14
855.33	0.13	855.85	0.13	856.37	0.13	856.89	0.14
855.34	0.13	855.86	0.13	856.38	0.13	856.90	0.14
855.35	0.13	855.87	0.13	856.39	0.14	856.91	0.14
855.36	0.13	855.88	0.13	856.40	0.14	856.92	0.14
855.37	0.13	855.89	0.13	856.41	0.14	856.93	0.14
855.38	0.13	855.90	0.13	856.42	0.14	856.94	0.14
855.39	0.13	855.91	0.13	856.43	0.14	856.95	0.14
855.40	0.13	855.92	0.13	856.44	0.14	856.96	0.14
855.41	0.13	855.93	0.13	856.45	0.14	856.97	0.14
855.42	0.13	855.94	0.13	856.46	0.14	856.98	0.14
855.43	0.13	855.95	0.13	856.47	0.14	856.99	0.14
855.44	0.13	855.96	0.13	856.48	0.14	857.00	0.14
855.45	0.13	855.97	0.13	856.49	0.14		
855.46	0.13	855.98	0.13	856.50	0.14		
855.47	0.13	855.99	0.13	856.51	0.14		
855.48	0.13	856.00	0.13	856.52	0.14		
855.49	0.13	856.01	0.13	856.53	0.14		
855.50	0.13	856.02	0.13	856.54	0.14		
855.51	0.13	856.03	0.13	856.55	0.14		

Stage-Area-Storage for Pond P3: Infiltration Area

Elevation (feet)	Surface (sq-ft)	Storage (cubic-feet)	Elevation (feet)	Surface (sq-ft)	Storage (cubic-feet)
855.00	10,679	0	856.04	10,679	11,106
855.02	10,679	214	856.06	10,679	11,320
855.04	10,679	427	856.08	10,679	11,533
855.06	10,679	641	856.10	10,679	11,747
855.08	10,679	854	856.12	10,679	11,960
855.10	10,679	1,068	856.14	10,679	12,174
855.12	10,679	1,281	856.16	10,679	12,388
855.14	10,679	1,495	856.18	10,679	12,601
855.16	10,679	1,709	856.20	10,679	12,815
855.18	10,679	1,922	856.22	10,679	13,028
855.20	10,679	2,136	856.24	10,679	13,242
855.22	10,679	2,349	856.26	10,679	13,456
855.24	10,679	2,563	856.28	10,679	13,669
855.26	10,679	2,777	856.30	10,679	13,883
855.28	10,679	2,990	856.32	10,679	14,096
855.30	10,679	3,204	856.34	10,679	14,310
855.32	10,679	3,417	856.36	10,679	14,523
855.34	10,679	3,631	856.38	10,679	14,737
855.36	10,679	3,844	856.40	10,679	14,951
855.38	10,679	4,058	856.42	10,679	15,164
855.40	10,679	4,272	856.44	10,679	15,378
855.42	10,679	4,485	856.46	10,679	15,591
855.44	10,679	4,699	856.48	10,679	15,805
855.46	10,679	4,912	856.50	10,679	16,019
855.48	10,679	5,126	856.52	10,679	16,232
855.50	10,679	5,340	856.54	10,679	16,446
855.52	10,679	5,553	856.56	10,679	16,659
855.54	10,679	5,767	856.58	10,679	16,873
855.56	10,679	5,980	856.60	10,679	17,086
855.58	10,679	6,194	856.62	10,679	17,300
855.60	10,679	6,407	856.64	10,679	17,514
855.62	10,679	6,621	856.66	10,679	17,727
855.64	10,679	6,835	856.68	10,679	17,941
855.66	10,679	7,048	856.70	10,679	18,154
855.68	10,679	7,262	856.72	10,679	18,368
855.70	10,679	7,475	856.74	10,679	18,581
855.72	10,679	7,689	856.76	10,679	18,795
855.74	10,679	7,902	856.78	10,679	19,009
855.76	10,679	8,116	856.80	10,679	19,222
855.78	10,679	8,330	856.82	10,679	19,436
855.80	10,679	8,543	856.84	10,679	19,649
855.82	10,679	8,757	856.86	10,679	19,863
855.84	10,679	8,970	856.88	10,679	20,077
855.86	10,679	9,184	856.90	10,679	20,290
855.88	10,679	9,398	856.92	10,679	20,504
855.90	10,679	9,611	856.94	10,679	20,717
855.92	10,679	9,825	856.96	10,679	20,931
855.94	10,679	10,038	856.98	10,679	21,144
855.96	10,679	10,252	857.00	10,679	21,358
855.98	10,679	10,465			
856.00	10,679	10,679			
856.02	10,679	10,893			

Summary for Pond P4: Mine Ponds

Inflow Area = 60.830 ac, 0.87% Impervious, Inflow Depth = 1.51" for 10-yr event
 Inflow = 81.16 cfs @ 12.23 hrs, Volume= 7.668 af
 Outflow = 3.44 cfs @ 16.96 hrs, Volume= 7.668 af, Atten= 96%, Lag= 283.5 min
 Primary = 3.44 cfs @ 16.96 hrs, Volume= 7.668 af

Routing by Stor-Ind method, Time Span= 0.05-168.00 hrs, dt= 0.05 hrs
 Starting Elev= 832.00' Surf.Area= 22,977 sf Storage= 61,614 cf
 Peak Elev= 838.33' @ 16.96 hrs Surf.Area= 50,733 sf Storage= 286,982 cf (225,368 cf above start)

Plug-Flow detention time= 1,418.2 min calculated for 6.252 af (82% of inflow)
 Center-of-Mass det. time= 1,103.3 min (1,966.2 - 862.9)

Volume	Invert	Avail.Storage	Storage Description
#1	826.00'	441,657 cf	Custom Stage Data (Prismatic) Listed below (Recalc)
Elevation (feet)	Surf.Area (sq-ft)	Inc.Store (cubic-feet)	Cum.Store (cubic-feet)
826.00	3,651	0	0
830.00	10,445	28,192	28,192
832.00	22,977	33,422	61,614
834.00	29,257	52,234	113,848
836.00	39,283	68,540	182,388
838.00	49,027	88,310	270,698
840.00	59,479	108,506	379,204
841.00	65,426	62,453	441,657

Device	Routing	Invert	Outlet Devices
#1	Primary	839.00'	8.0' long x 4.0' breadth Broad-Crested Rectangular Weir Head (feet) 0.20 0.40 0.60 0.80 1.00 1.20 1.40 1.60 1.80 2.00 2.50 3.00 3.50 4.00 4.50 5.00 5.50 Coef. (English) 2.38 2.54 2.69 2.68 2.67 2.67 2.65 2.66 2.66 2.68 2.72 2.73 2.76 2.79 2.88 3.07 3.32
#2	Device 5	838.50'	20.0' long Sharp-Crested Rectangular Weir 0 End Contraction(s)
#3	Device 5	838.20'	3.5' long x 0.30' rise Sharp-Crested Rectangular Weir X 2.00 2 End Contraction(s)
#4	Device 5	832.00'	3.0" Vert. Orifice/Grate X 4.00 C= 0.600
#5	Primary	832.00'	24.0" Round Culvert L= 118.0' CPP, square edge headwall, Ke= 0.500 Inlet / Outlet Invert= 832.00' / 831.00' S= 0.0085 '/' Cc= 0.900 n= 0.013, Flow Area= 3.14 sf

Primary OutFlow Max=3.38 cfs @ 16.96 hrs HW=838.33' (Free Discharge)
 1=Broad-Crested Rectangular Weir (Controls 0.00 cfs)
 5=Culvert (Passes 3.38 cfs of 33.76 cfs potential flow)
 2=Sharp-Crested Rectangular Weir (Controls 0.00 cfs)
 3=Sharp-Crested Rectangular Weir (Weir Controls 1.02 cfs @ 1.16 fps)
 4=Orifice/Grate (Orifice Controls 2.35 cfs @ 11.99 fps)

Pond P4: Mine Ponds

Hydrograph

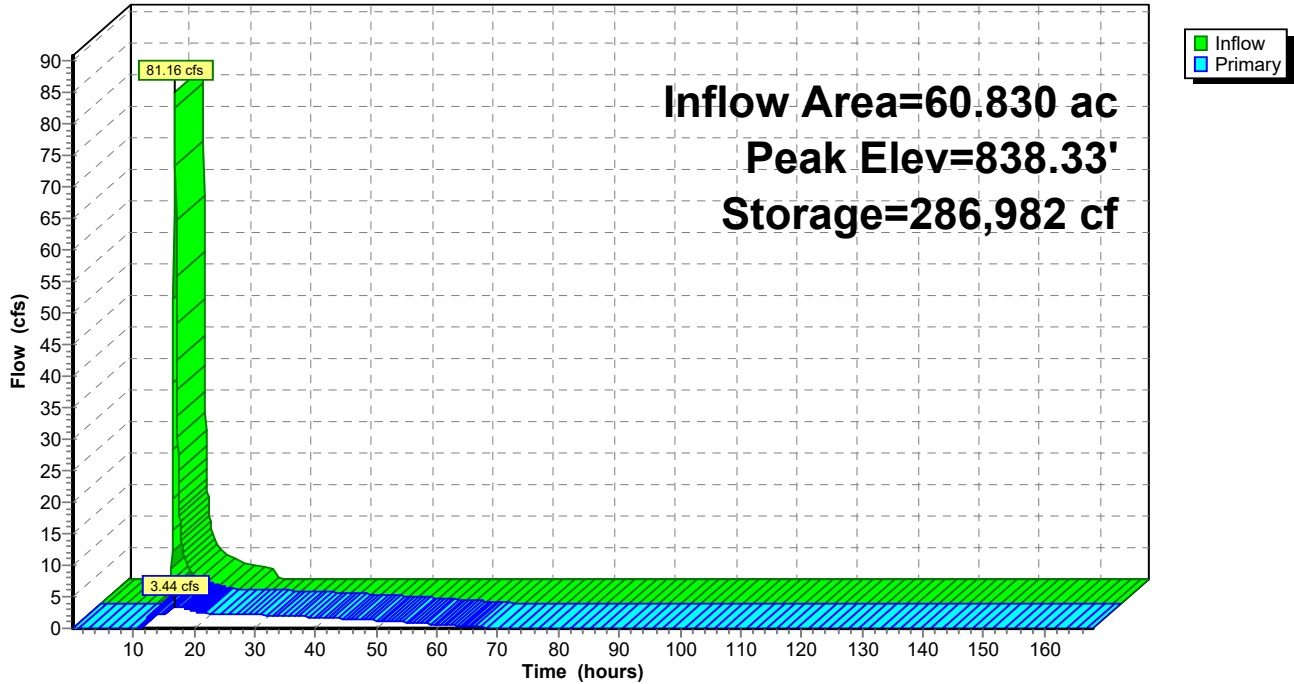

Pond P4: Mine Ponds

Stage-Discharge

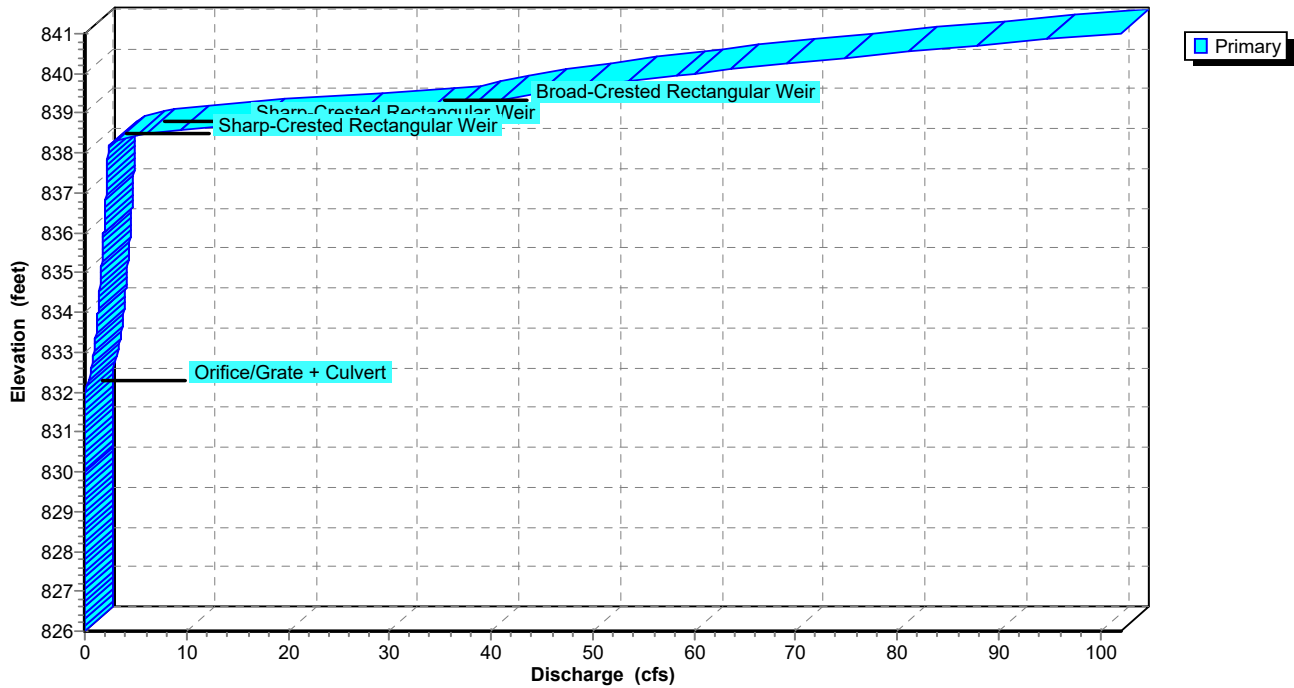

Pond P4: Mine Ponds

Stage-Area-Storage

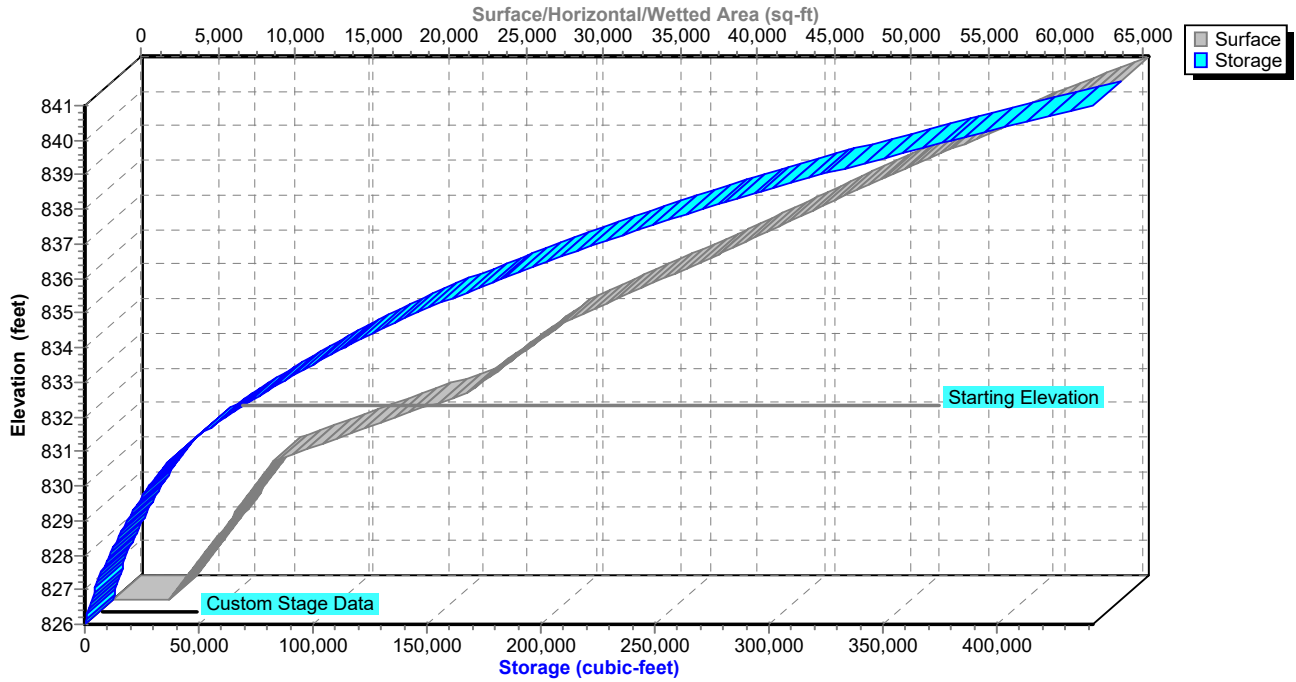

Hydrograph for Pond P4: Mine Ponds

Time (hours)	Inflow (cfs)	Storage (cubic-feet)	Elevation (feet)	Primary (cfs)
0.05	0.00	61,614	832.00	0.00
5.05	0.00	61,614	832.00	0.00
10.05	0.07	61,640	832.00	0.00
15.05	5.05	279,495	838.18	2.33
20.05	2.27	283,742	838.26	2.79
25.05	0.03	271,984	838.03	2.30
30.05	0.00	232,176	837.18	2.13
35.05	0.00	195,572	836.33	1.94
40.05	0.00	162,517	835.48	1.73
45.05	0.00	133,421	834.63	1.50
50.05	0.00	108,798	833.83	1.23
55.05	0.00	89,204	833.12	0.94
60.05	0.00	75,081	832.56	0.62
65.05	0.00	66,910	832.23	0.26
70.05	0.00	64,196	832.11	0.09
75.05	0.00	62,961	832.06	0.05
80.05	0.00	62,316	832.03	0.03
85.05	0.00	61,980	832.02	0.01
90.05	0.00	61,805	832.01	0.01
95.05	0.00	61,714	832.00	0.00
100.05	0.00	61,666	832.00	0.00
105.05	0.00	61,641	832.00	0.00
110.05	0.00	61,628	832.00	0.00
115.05	0.00	61,621	832.00	0.00
120.05	0.00	61,618	832.00	0.00
125.05	0.00	61,616	832.00	0.00
130.05	0.00	61,615	832.00	0.00
135.05	0.00	61,615	832.00	0.00
140.05	0.00	61,614	832.00	0.00
145.05	0.00	61,614	832.00	0.00
150.05	0.00	61,614	832.00	0.00
155.05	0.00	61,614	832.00	0.00
160.05	0.00	61,614	832.00	0.00
165.05	0.00	61,614	832.00	0.00

Stage-Discharge for Pond P4: Mine Ponds

Elevation (feet)	Primary (cfs)	Elevation (feet)	Primary (cfs)
826.00	0.00	833.80	1.22
826.15	0.00	833.95	1.28
826.30	0.00	834.10	1.33
826.45	0.00	834.25	1.38
826.60	0.00	834.40	1.43
826.75	0.00	834.55	1.47
826.90	0.00	834.70	1.52
827.05	0.00	834.85	1.56
827.20	0.00	835.00	1.60
827.35	0.00	835.15	1.64
827.50	0.00	835.30	1.68
827.65	0.00	835.45	1.72
827.80	0.00	835.60	1.76
827.95	0.00	835.75	1.80
828.10	0.00	835.90	1.84
828.25	0.00	836.05	1.87
828.40	0.00	836.20	1.91
828.55	0.00	836.35	1.94
828.70	0.00	836.50	1.98
828.85	0.00	836.65	2.01
829.00	0.00	836.80	2.04
829.15	0.00	836.95	2.08
829.30	0.00	837.10	2.11
829.45	0.00	837.25	2.14
829.60	0.00	837.40	2.17
829.75	0.00	837.55	2.20
829.90	0.00	837.70	2.23
830.05	0.00	837.85	2.26
830.20	0.00	838.00	2.29
830.35	0.00	838.15	2.32
830.50	0.00	838.30	3.07
830.65	0.00	838.45	5.20
830.80	0.00	838.60	9.45
830.95	0.00	838.75	16.97
831.10	0.00	838.90	26.49
831.25	0.00	839.05	36.19
831.40	0.00	839.20	38.13
831.55	0.00	839.35	41.00
831.70	0.00	839.50	44.69
831.85	0.00	839.65	48.99
832.00	0.00	839.80	53.48
832.15	0.13	839.95	58.36
832.30	0.40	840.10	63.62
832.45	0.54	840.25	69.18
832.60	0.65	840.40	74.91
832.75	0.75	840.55	81.22
832.90	0.83	840.70	87.76
833.05	0.91	840.85	94.63
833.20	0.98	841.00	102.01
833.35	1.05		
833.50	1.11		
833.65	1.17		

Stage-Area-Storage for Pond P4: Mine Ponds

Elevation (feet)	Surface (sq-ft)	Storage (cubic-feet)	Elevation (feet)	Surface (sq-ft)	Storage (cubic-feet)
826.00	3,651	0	833.80	28,629	108,059
826.15	3,906	567	833.95	29,100	112,389
826.30	4,161	1,172	834.10	29,758	116,799
826.45	4,415	1,815	834.25	30,510	121,319
826.60	4,670	2,496	834.40	31,262	125,952
826.75	4,925	3,216	834.55	32,014	130,698
826.90	5,180	3,974	834.70	32,766	135,556
827.05	5,434	4,770	834.85	33,518	140,527
827.20	5,689	5,604	835.00	34,270	145,612
827.35	5,944	6,477	835.15	35,022	150,808
827.50	6,199	7,387	835.30	35,774	156,118
827.65	6,454	8,336	835.45	36,526	161,541
827.80	6,708	9,323	835.60	37,278	167,076
827.95	6,963	10,349	835.75	38,030	172,724
828.10	7,218	11,412	835.90	38,782	178,485
828.25	7,473	12,514	836.05	39,527	184,358
828.40	7,727	13,654	836.20	40,257	190,342
828.55	7,982	14,832	836.35	40,988	196,435
828.70	8,237	16,049	836.50	41,719	202,639
828.85	8,492	17,303	836.65	42,450	208,951
829.00	8,747	18,596	836.80	43,181	215,373
829.15	9,001	19,927	836.95	43,911	221,905
829.30	9,256	21,297	837.10	44,642	228,547
829.45	9,511	22,704	837.25	45,373	235,298
829.60	9,766	24,150	837.40	46,104	242,159
829.75	10,020	25,634	837.55	46,835	249,129
829.90	10,275	27,156	837.70	47,565	256,209
830.05	10,758	28,722	837.85	48,296	263,399
830.20	11,698	30,406	838.00	49,027	270,698
830.35	12,638	32,232	838.15	49,811	278,111
830.50	13,578	34,198	838.30	50,595	285,641
830.65	14,518	36,305	838.45	51,379	293,289
830.80	15,458	38,553	838.60	52,163	301,055
830.95	16,398	40,942	838.75	52,947	308,938
831.10	17,338	43,472	838.90	53,730	316,939
831.25	18,278	46,144	839.05	54,514	325,057
831.40	19,217	48,956	839.20	55,298	333,293
831.55	20,157	51,909	839.35	56,082	341,647
831.70	21,097	55,003	839.50	56,866	350,118
831.85	22,037	58,238	839.65	57,650	358,706
832.00	22,977	61,614	839.80	58,434	367,413
832.15	23,448	65,096	839.95	59,218	376,237
832.30	23,919	68,648	840.10	60,074	385,182
832.45	24,390	72,272	840.25	60,966	394,260
832.60	24,861	75,965	840.40	61,858	403,471
832.75	25,332	79,730	840.55	62,750	412,817
832.90	25,803	83,565	840.70	63,642	422,296
833.05	26,274	87,471	840.85	64,534	431,910
833.20	26,745	91,447	841.00	65,426	441,657
833.35	27,216	95,494			
833.50	27,687	99,612			
833.65	28,158	103,800			

IGN Padua Ridge Pre-Reclaimed v2 sharp weir

Type II 24-hr 25-yr Rainfall=4.39"

Prepared by JMT

Printed 1/31/2022

HydroCAD® 10.00-20 s/n 02102 © 2017 HydroCAD Software Solutions LLC

Page 38

Time span=0.05-168.00 hrs, dt=0.05 hrs, 3360 points
 Runoff by SCS TR-20 method, UH=SCS, Weighted-CN
 Reach routing by Stor-Ind+Trans method - Pond routing by Stor-Ind method

Subcatchment1: Area 1 Runoff Area=279,272 sf 0.00% Impervious Runoff Depth=0.74"
 Flow Length=853' Tc=11.1 min CN=56 Runoff=5.67 cfs 0.398 af

Subcatchment3: Area 3 Runoff Area=240,062 sf 0.00% Impervious Runoff Depth=0.20"
 Flow Length=800' Tc=12.2 min CN=43 Runoff=0.22 cfs 0.093 af

Subcatchment4: Area 4 Runoff Area=60.830 ac 0.87% Impervious Runoff Depth=2.12"
 Flow Length=2,350' Tc=28.1 min CN=77 Runoff=115.55 cfs 10.755 af

Subcatchment8: Downslope Area Runoff Area=1,214,716 sf 0.00% Impervious Runoff Depth=1.67"
 Flow Length=850' Tc=17.7 min CN=71 Runoff=53.80 cfs 3.874 af

Reach R1: Drainage Easement Avg. Flow Depth=2.17' Max Vel=6.88 fps Inflow=55.28 cfs 14.629 af
 n=0.030 L=1,890.0' S=0.0180 '/' Capacity=97.49 cfs Outflow=50.21 cfs 14.629 af

Pond P1: Infiltration Area Peak Elev=855.99' Storage=11,177 cf Inflow=5.67 cfs 0.398 af
 Outflow=0.14 cfs 0.398 af

Pond P3: Infiltration Area Peak Elev=855.04' Storage=399 cf Inflow=0.22 cfs 0.093 af
 Outflow=0.12 cfs 0.093 af

Pond P4: Mine Ponds Peak Elev=838.78' Storage=310,325 cf Inflow=115.55 cfs 10.755 af
 Outflow=18.63 cfs 10.755 af

Total Runoff Area = 100.638 ac Runoff Volume = 15.119 af Average Runoff Depth = 1.80"
99.47% Pervious = 100.108 ac 0.53% Impervious = 0.530 ac

Summary for Subcatchment 1: Area 1

Runoff = 5.67 cfs @ 12.05 hrs, Volume= 0.398 af, Depth= 0.74"

Runoff by SCS TR-20 method, UH=SCS, Weighted-CN, Time Span= 0.05-168.00 hrs, dt= 0.05 hrs
 Type II 24-hr 25-yr Rainfall=4.39"

Area (sf)	CN	Description
56,691	85	Gravel roads, HSG B
144,643	58	Woods/grass comb., Good, HSG B
77,938	30	Woods, Good, HSG A
279,272	56	Weighted Average
279,272		100.00% Pervious Area

Tc (min)	Length (feet)	Slope (ft/ft)	Velocity (ft/sec)	Capacity (cfs)	Description
3.9	100	0.3000	0.43		Sheet Flow, Grass: Short n= 0.150 P2= 2.35"
2.6	415	0.1400	2.62		Shallow Concentrated Flow, Short Grass Pasture Kv= 7.0 fps
4.6	338	0.0300	1.21		Shallow Concentrated Flow, Short Grass Pasture Kv= 7.0 fps
11.1	853	Total			

Subcatchment 1: Area 1

Hydrograph

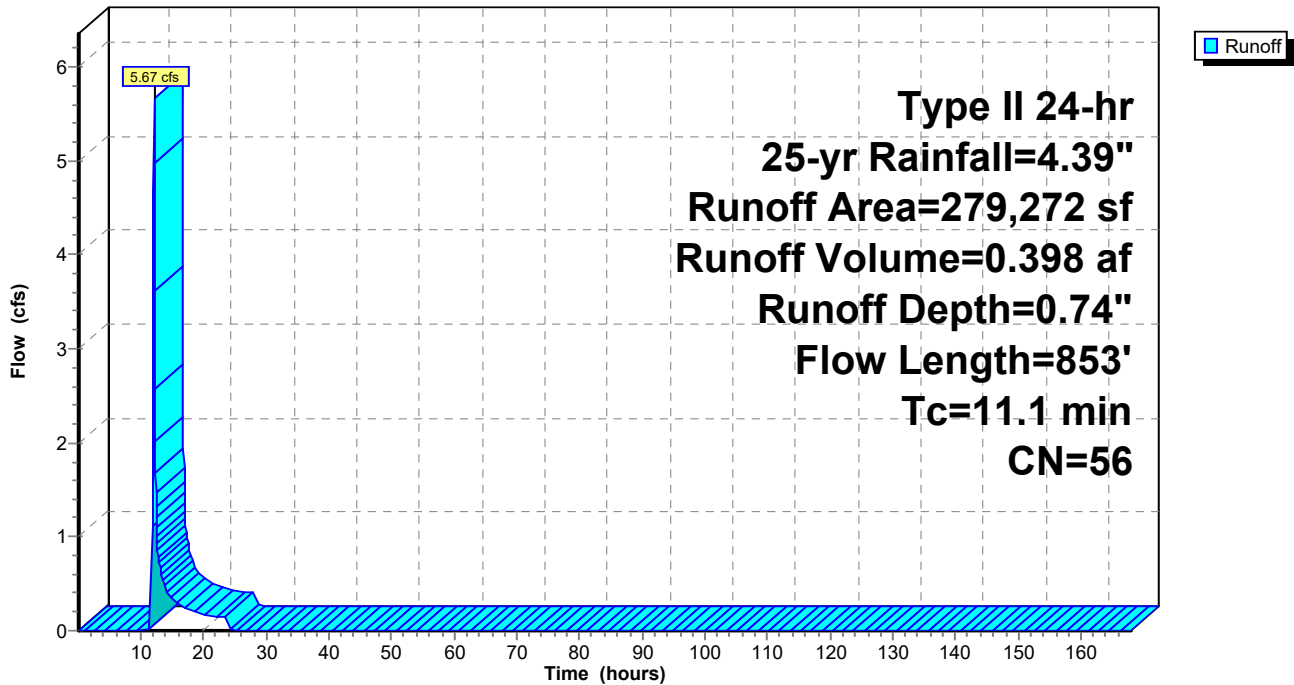

Hydrograph for Subcatchment 1: Area 1

Time (hours)	Precip. (inches)	Excess (inches)	Runoff (cfs)	Time (hours)	Precip. (inches)	Excess (inches)	Runoff (cfs)
0.05	0.00	0.00	0.00	130.05	4.39	0.74	0.00
2.55	0.13	0.00	0.00	132.55	4.39	0.74	0.00
5.05	0.28	0.00	0.00	135.05	4.39	0.74	0.00
7.55	0.48	0.00	0.00	137.55	4.39	0.74	0.00
10.05	0.80	0.00	0.00	140.05	4.39	0.74	0.00
12.55	3.25	0.29	1.01	142.55	4.39	0.74	0.00
15.05	3.75	0.47	0.34	145.05	4.39	0.74	0.00
17.55	4.01	0.58	0.23	147.55	4.39	0.74	0.00
20.05	4.18	0.65	0.16	150.05	4.39	0.74	0.00
22.55	4.32	0.71	0.15	152.55	4.39	0.74	0.00
25.05	4.39	0.74	0.00	155.05	4.39	0.74	0.00
27.55	4.39	0.74	0.00	157.55	4.39	0.74	0.00
30.05	4.39	0.74	0.00	160.05	4.39	0.74	0.00
32.55	4.39	0.74	0.00	162.55	4.39	0.74	0.00
35.05	4.39	0.74	0.00	165.05	4.39	0.74	0.00
37.55	4.39	0.74	0.00	167.55	4.39	0.74	0.00
40.05	4.39	0.74	0.00				
42.55	4.39	0.74	0.00				
45.05	4.39	0.74	0.00				
47.55	4.39	0.74	0.00				
50.05	4.39	0.74	0.00				
52.55	4.39	0.74	0.00				
55.05	4.39	0.74	0.00				
57.55	4.39	0.74	0.00				
60.05	4.39	0.74	0.00				
62.55	4.39	0.74	0.00				
65.05	4.39	0.74	0.00				
67.55	4.39	0.74	0.00				
70.05	4.39	0.74	0.00				
72.55	4.39	0.74	0.00				
75.05	4.39	0.74	0.00				
77.55	4.39	0.74	0.00				
80.05	4.39	0.74	0.00				
82.55	4.39	0.74	0.00				
85.05	4.39	0.74	0.00				
87.55	4.39	0.74	0.00				
90.05	4.39	0.74	0.00				
92.55	4.39	0.74	0.00				
95.05	4.39	0.74	0.00				
97.55	4.39	0.74	0.00				
100.05	4.39	0.74	0.00				
102.55	4.39	0.74	0.00				
105.05	4.39	0.74	0.00				
107.55	4.39	0.74	0.00				
110.05	4.39	0.74	0.00				
112.55	4.39	0.74	0.00				
115.05	4.39	0.74	0.00				
117.55	4.39	0.74	0.00				
120.05	4.39	0.74	0.00				
122.55	4.39	0.74	0.00				
125.05	4.39	0.74	0.00				
127.55	4.39	0.74	0.00				

Summary for Subcatchment 3: Area 3

Runoff = 0.22 cfs @ 12.39 hrs, Volume= 0.093 af, Depth= 0.20"

Runoff by SCS TR-20 method, UH=SCS, Weighted-CN, Time Span= 0.05-168.00 hrs, dt= 0.05 hrs
 Type II 24-hr 25-yr Rainfall=4.39"

Area (sf)	CN	Description
45,301	85	Gravel roads, HSG B
25,552	58	Woods/grass comb., Good, HSG B
169,209	30	Woods, Good, HSG A
240,062	43	Weighted Average
240,062		100.00% Pervious Area

Tc (min)	Length (feet)	Slope (ft/ft)	Velocity (ft/sec)	Capacity (cfs)	Description
6.2	100	0.6600	0.27		Sheet Flow, Woods: Light underbrush n= 0.400 P2= 2.35"
3.1	450	0.1200	2.42		Shallow Concentrated Flow, Short Grass Pasture Kv= 7.0 fps
1.9	110	0.0200	0.99		Shallow Concentrated Flow, Short Grass Pasture Kv= 7.0 fps
1.0	140	0.1100	2.32		Shallow Concentrated Flow, Short Grass Pasture Kv= 7.0 fps
12.2	800	Total			

Subcatchment 3: Area 3

Hydrograph

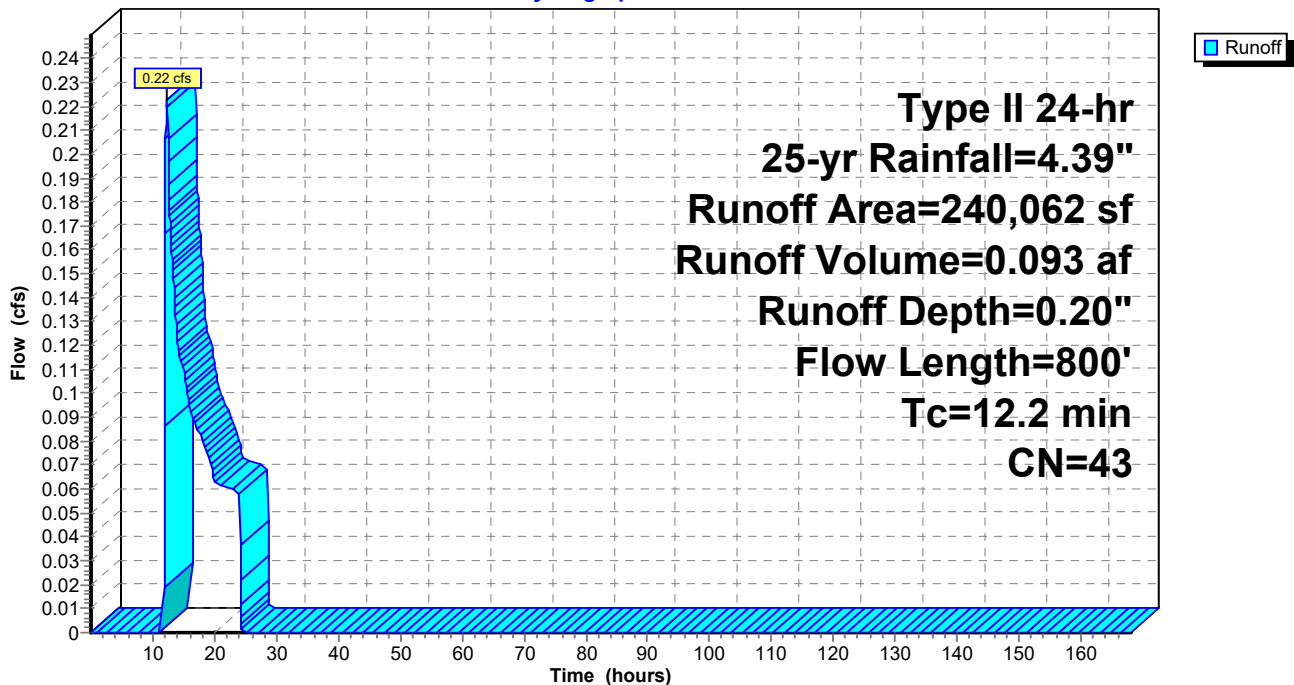

Hydrograph for Subcatchment 3: Area 3

Time (hours)	Precip. (inches)	Excess (inches)	Runoff (cfs)	Time (hours)	Precip. (inches)	Excess (inches)	Runoff (cfs)
0.05	0.00	0.00	0.00	130.05	4.39	0.20	0.00
2.55	0.13	0.00	0.00	132.55	4.39	0.20	0.00
5.05	0.28	0.00	0.00	135.05	4.39	0.20	0.00
7.55	0.48	0.00	0.00	137.55	4.39	0.20	0.00
10.05	0.80	0.00	0.00	140.05	4.39	0.20	0.00
12.55	3.25	0.03	0.21	142.55	4.39	0.20	0.00
15.05	3.75	0.08	0.11	145.05	4.39	0.20	0.00
17.55	4.01	0.13	0.08	147.55	4.39	0.20	0.00
20.05	4.18	0.16	0.06	150.05	4.39	0.20	0.00
22.55	4.32	0.19	0.06	152.55	4.39	0.20	0.00
25.05	4.39	0.20	0.00	155.05	4.39	0.20	0.00
27.55	4.39	0.20	0.00	157.55	4.39	0.20	0.00
30.05	4.39	0.20	0.00	160.05	4.39	0.20	0.00
32.55	4.39	0.20	0.00	162.55	4.39	0.20	0.00
35.05	4.39	0.20	0.00	165.05	4.39	0.20	0.00
37.55	4.39	0.20	0.00	167.55	4.39	0.20	0.00
40.05	4.39	0.20	0.00				
42.55	4.39	0.20	0.00				
45.05	4.39	0.20	0.00				
47.55	4.39	0.20	0.00				
50.05	4.39	0.20	0.00				
52.55	4.39	0.20	0.00				
55.05	4.39	0.20	0.00				
57.55	4.39	0.20	0.00				
60.05	4.39	0.20	0.00				
62.55	4.39	0.20	0.00				
65.05	4.39	0.20	0.00				
67.55	4.39	0.20	0.00				
70.05	4.39	0.20	0.00				
72.55	4.39	0.20	0.00				
75.05	4.39	0.20	0.00				
77.55	4.39	0.20	0.00				
80.05	4.39	0.20	0.00				
82.55	4.39	0.20	0.00				
85.05	4.39	0.20	0.00				
87.55	4.39	0.20	0.00				
90.05	4.39	0.20	0.00				
92.55	4.39	0.20	0.00				
95.05	4.39	0.20	0.00				
97.55	4.39	0.20	0.00				
100.05	4.39	0.20	0.00				
102.55	4.39	0.20	0.00				
105.05	4.39	0.20	0.00				
107.55	4.39	0.20	0.00				
110.05	4.39	0.20	0.00				
112.55	4.39	0.20	0.00				
115.05	4.39	0.20	0.00				
117.55	4.39	0.20	0.00				
120.05	4.39	0.20	0.00				
122.55	4.39	0.20	0.00				
125.05	4.39	0.20	0.00				
127.55	4.39	0.20	0.00				

Summary for Subcatchment 4: Area 4

Runoff = 115.55 cfs @ 12.23 hrs, Volume= 10.755 af, Depth= 2.12"

Runoff by SCS TR-20 method, UH=SCS, Weighted-CN, Time Span= 0.05-168.00 hrs, dt= 0.05 hrs
 Type II 24-hr 25-yr Rainfall=4.39"

Area (ac)	CN	Description
60.300	77	Newly graded area, HSG A
0.530	98	Water Surface, HSG A
60.830	77	Weighted Average
60.300		99.13% Pervious Area
0.530		0.87% Impervious Area

Tc (min)	Length (feet)	Slope (ft/ft)	Velocity (ft/sec)	Capacity (cfs)	Description
7.9	100	0.0500	0.21		Sheet Flow, Grass: Short n= 0.150 P2= 2.35"
20.2	2,250	0.0700	1.85		Shallow Concentrated Flow, Short Grass Pasture Kv= 7.0 fps
28.1	2,350	Total			

Subcatchment 4: Area 4

Hydrograph

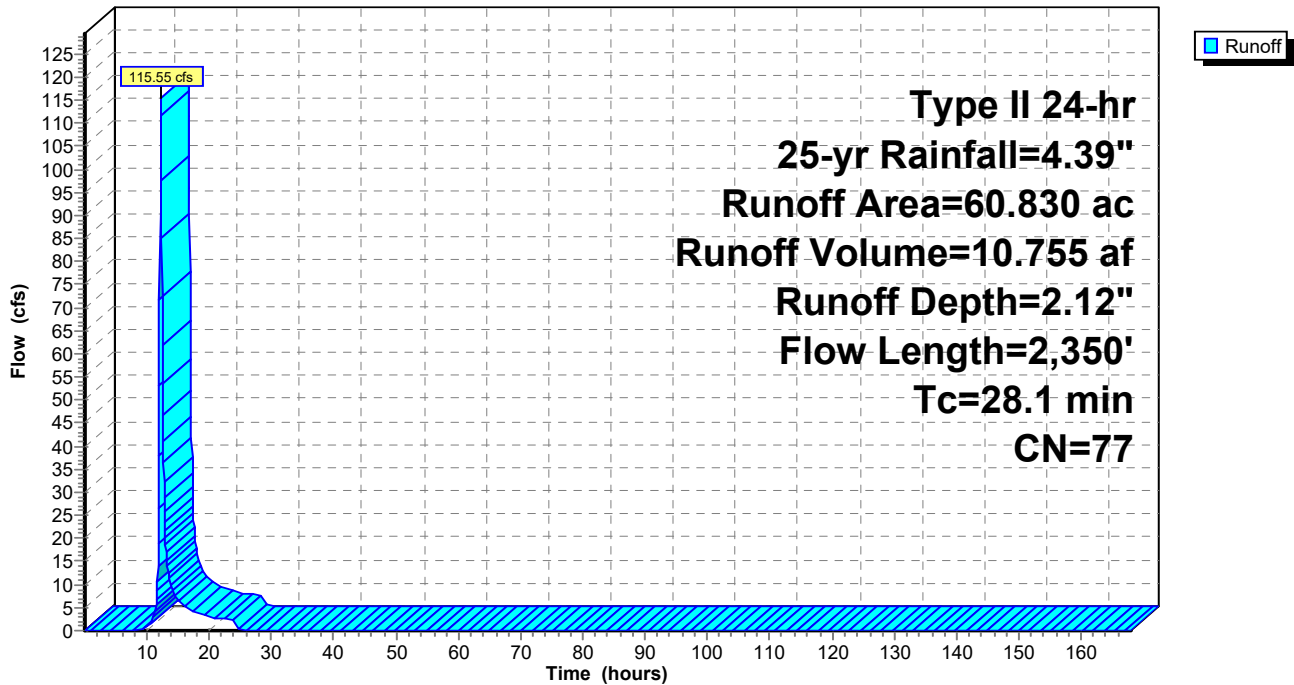

IGN Padua Ridge Pre-Reclaimed v2 sharp weir

Type II 24-hr 25-yr Rainfall=4.39"

Prepared by JMT

Printed 1/31/2022

HydroCAD® 10.00-20 s/n 02102 © 2017 HydroCAD Software Solutions LLC

Page 44

Hydrograph for Subcatchment 4: Area 4

Time (hours)	Precip. (inches)	Excess (inches)	Runoff (cfs)	Time (hours)	Precip. (inches)	Excess (inches)	Runoff (cfs)
0.05	0.00	0.00	0.00	130.05	4.39	2.12	0.00
2.55	0.13	0.00	0.00	132.55	4.39	2.12	0.00
5.05	0.28	0.00	0.00	135.05	4.39	2.12	0.00
7.55	0.48	0.00	0.00	137.55	4.39	2.12	0.00
10.05	0.80	0.01	0.80	140.05	4.39	2.12	0.00
12.55	3.25	1.24	53.54	142.55	4.39	2.12	0.00
15.05	3.75	1.62	6.68	145.05	4.39	2.12	0.00
17.55	4.01	1.82	4.24	147.55	4.39	2.12	0.00
20.05	4.18	1.96	2.98	150.05	4.39	2.12	0.00
22.55	4.32	2.06	2.57	152.55	4.39	2.12	0.00
25.05	4.39	2.12	0.04	155.05	4.39	2.12	0.00
27.55	4.39	2.12	0.00	157.55	4.39	2.12	0.00
30.05	4.39	2.12	0.00	160.05	4.39	2.12	0.00
32.55	4.39	2.12	0.00	162.55	4.39	2.12	0.00
35.05	4.39	2.12	0.00	165.05	4.39	2.12	0.00
37.55	4.39	2.12	0.00	167.55	4.39	2.12	0.00
40.05	4.39	2.12	0.00				
42.55	4.39	2.12	0.00				
45.05	4.39	2.12	0.00				
47.55	4.39	2.12	0.00				
50.05	4.39	2.12	0.00				
52.55	4.39	2.12	0.00				
55.05	4.39	2.12	0.00				
57.55	4.39	2.12	0.00				
60.05	4.39	2.12	0.00				
62.55	4.39	2.12	0.00				
65.05	4.39	2.12	0.00				
67.55	4.39	2.12	0.00				
70.05	4.39	2.12	0.00				
72.55	4.39	2.12	0.00				
75.05	4.39	2.12	0.00				
77.55	4.39	2.12	0.00				
80.05	4.39	2.12	0.00				
82.55	4.39	2.12	0.00				
85.05	4.39	2.12	0.00				
87.55	4.39	2.12	0.00				
90.05	4.39	2.12	0.00				
92.55	4.39	2.12	0.00				
95.05	4.39	2.12	0.00				
97.55	4.39	2.12	0.00				
100.05	4.39	2.12	0.00				
102.55	4.39	2.12	0.00				
105.05	4.39	2.12	0.00				
107.55	4.39	2.12	0.00				
110.05	4.39	2.12	0.00				
112.55	4.39	2.12	0.00				
115.05	4.39	2.12	0.00				
117.55	4.39	2.12	0.00				
120.05	4.39	2.12	0.00				
122.55	4.39	2.12	0.00				
125.05	4.39	2.12	0.00				
127.55	4.39	2.12	0.00				

Summary for Subcatchment 8: Downslope Area

Runoff = 53.80 cfs @ 12.11 hrs, Volume= 3.874 af, Depth= 1.67"

Runoff by SCS TR-20 method, UH=SCS, Weighted-CN, Time Span= 0.05-168.00 hrs, dt= 0.05 hrs
 Type II 24-hr 25-yr Rainfall=4.39"

Area (sf)	CN	Description
138,897	32	Woods/grass comb., Good, HSG A
164,655	58	Woods/grass comb., Good, HSG B
33,867	85	Gravel roads, HSG B
877,297	79	Woods/grass comb., Good, HSG D
1,214,716	71	Weighted Average
1,214,716		100.00% Pervious Area

Tc (min)	Length (feet)	Slope (ft/ft)	Velocity (ft/sec)	Capacity (cfs)	Description
11.2	100	0.1500	0.15		Sheet Flow, Woods: Light underbrush n= 0.400 P2= 2.35"
6.5	750	0.1460	1.91		Shallow Concentrated Flow, Woodland Kv= 5.0 fps
17.7	850	Total			

Subcatchment 8: Downslope Area

Hydrograph

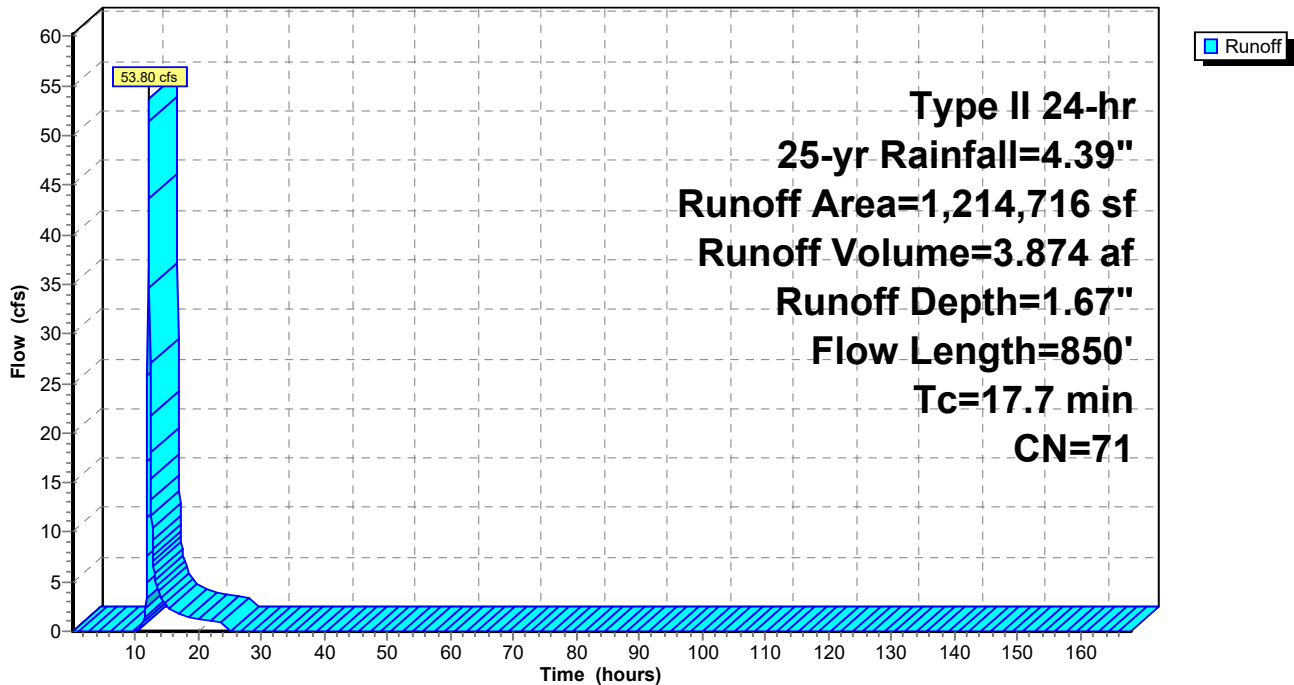

IGN Padua Ridge Pre-Reclaimed v2 sharp weir

Type II 24-hr 25-yr Rainfall=4.39"

Prepared by JMT

Printed 1/31/2022

HydroCAD® 10.00-20 s/n 02102 © 2017 HydroCAD Software Solutions LLC

Page 46

Hydrograph for Subcatchment 8: Downslope Area

Time (hours)	Precip. (inches)	Excess (inches)	Runoff (cfs)	Time (hours)	Precip. (inches)	Excess (inches)	Runoff (cfs)
0.05	0.00	0.00	0.00	130.05	4.39	1.67	0.00
2.55	0.13	0.00	0.00	132.55	4.39	1.67	0.00
5.05	0.28	0.00	0.00	135.05	4.39	1.67	0.00
7.55	0.48	0.00	0.00	137.55	4.39	1.67	0.00
10.05	0.80	0.00	0.00	140.05	4.39	1.67	0.00
12.55	3.25	0.91	11.71	142.55	4.39	1.67	0.00
15.05	3.75	1.23	2.56	145.05	4.39	1.67	0.00
17.55	4.01	1.40	1.67	147.55	4.39	1.67	0.00
20.05	4.18	1.52	1.17	150.05	4.39	1.67	0.00
22.55	4.32	1.62	1.04	152.55	4.39	1.67	0.00
25.05	4.39	1.67	0.00	155.05	4.39	1.67	0.00
27.55	4.39	1.67	0.00	157.55	4.39	1.67	0.00
30.05	4.39	1.67	0.00	160.05	4.39	1.67	0.00
32.55	4.39	1.67	0.00	162.55	4.39	1.67	0.00
35.05	4.39	1.67	0.00	165.05	4.39	1.67	0.00
37.55	4.39	1.67	0.00	167.55	4.39	1.67	0.00
40.05	4.39	1.67	0.00				
42.55	4.39	1.67	0.00				
45.05	4.39	1.67	0.00				
47.55	4.39	1.67	0.00				
50.05	4.39	1.67	0.00				
52.55	4.39	1.67	0.00				
55.05	4.39	1.67	0.00				
57.55	4.39	1.67	0.00				
60.05	4.39	1.67	0.00				
62.55	4.39	1.67	0.00				
65.05	4.39	1.67	0.00				
67.55	4.39	1.67	0.00				
70.05	4.39	1.67	0.00				
72.55	4.39	1.67	0.00				
75.05	4.39	1.67	0.00				
77.55	4.39	1.67	0.00				
80.05	4.39	1.67	0.00				
82.55	4.39	1.67	0.00				
85.05	4.39	1.67	0.00				
87.55	4.39	1.67	0.00				
90.05	4.39	1.67	0.00				
92.55	4.39	1.67	0.00				
95.05	4.39	1.67	0.00				
97.55	4.39	1.67	0.00				
100.05	4.39	1.67	0.00				
102.55	4.39	1.67	0.00				
105.05	4.39	1.67	0.00				
107.55	4.39	1.67	0.00				
110.05	4.39	1.67	0.00				
112.55	4.39	1.67	0.00				
115.05	4.39	1.67	0.00				
117.55	4.39	1.67	0.00				
120.05	4.39	1.67	0.00				
122.55	4.39	1.67	0.00				
125.05	4.39	1.67	0.00				
127.55	4.39	1.67	0.00				

Summary for Reach R1: Drainage Easement

Inflow Area = 88.716 ac, 0.60% Impervious, Inflow Depth = 1.98" for 25-yr event
 Inflow = 55.28 cfs @ 12.11 hrs, Volume= 14.629 af
 Outflow = 50.21 cfs @ 12.25 hrs, Volume= 14.629 af, Atten= 9%, Lag= 8.1 min

Routing by Stor-Ind+Trans method, Time Span= 0.05-168.00 hrs, dt= 0.05 hrs
 Max. Velocity= 6.88 fps, Min. Travel Time= 4.6 min
 Avg. Velocity = 1.67 fps, Avg. Travel Time= 18.9 min

Peak Storage= 13,980 cf @ 12.17 hrs
 Average Depth at Peak Storage= 2.17'
 Bank-Full Depth= 3.00' Flow Area= 12.0 sf, Capacity= 97.49 cfs

6.00' x 3.00' deep Parabolic Channel, n= 0.030 Earth, grassed & winding
 Length= 1,890.0' Slope= 0.0180 '/'
 Inlet Invert= 780.00', Outlet Invert= 746.00'

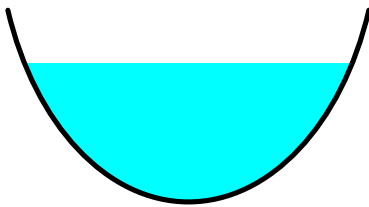

Reach R1: Drainage Easement

Hydrograph

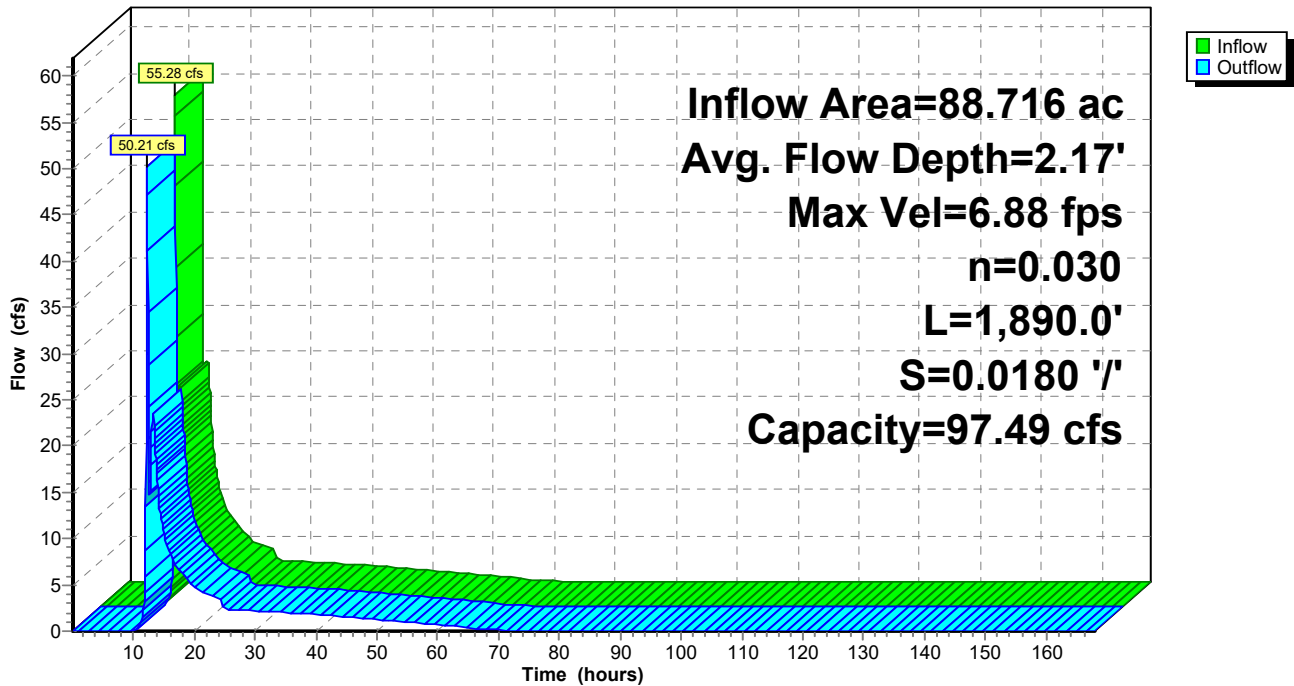

Reach R1: Drainage Easement

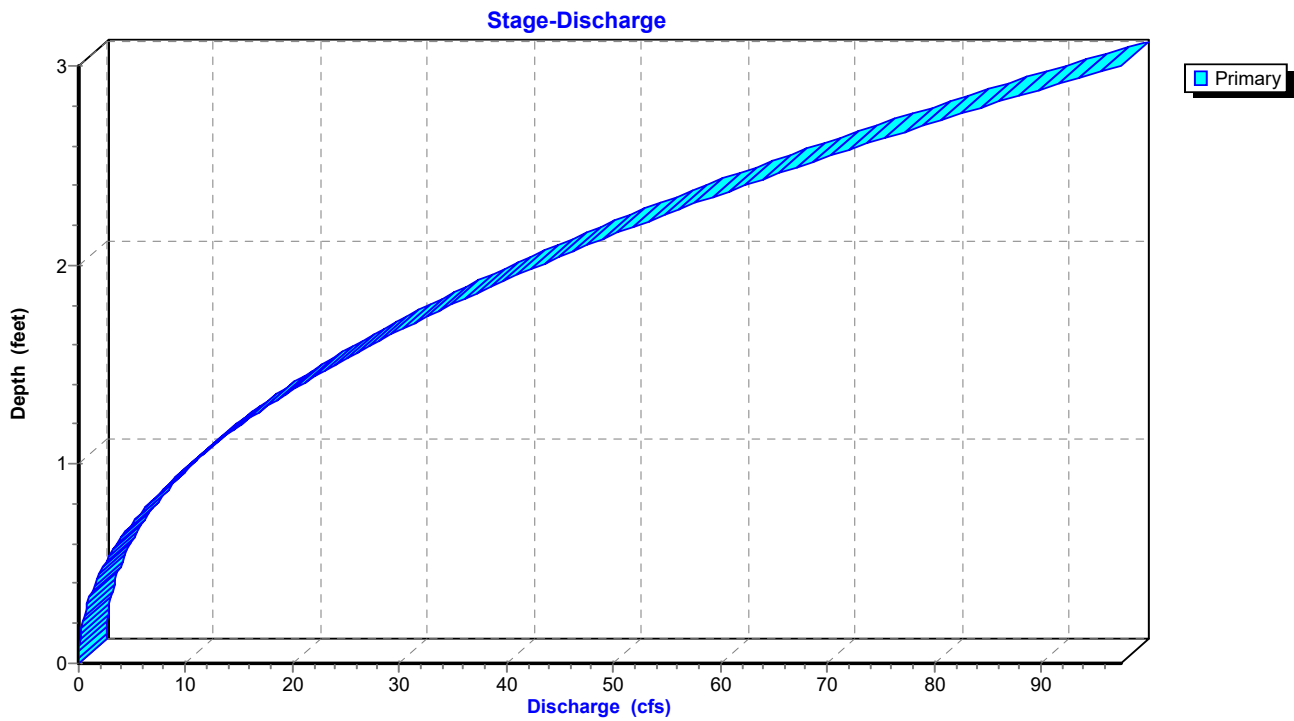

Reach R1: Drainage Easement

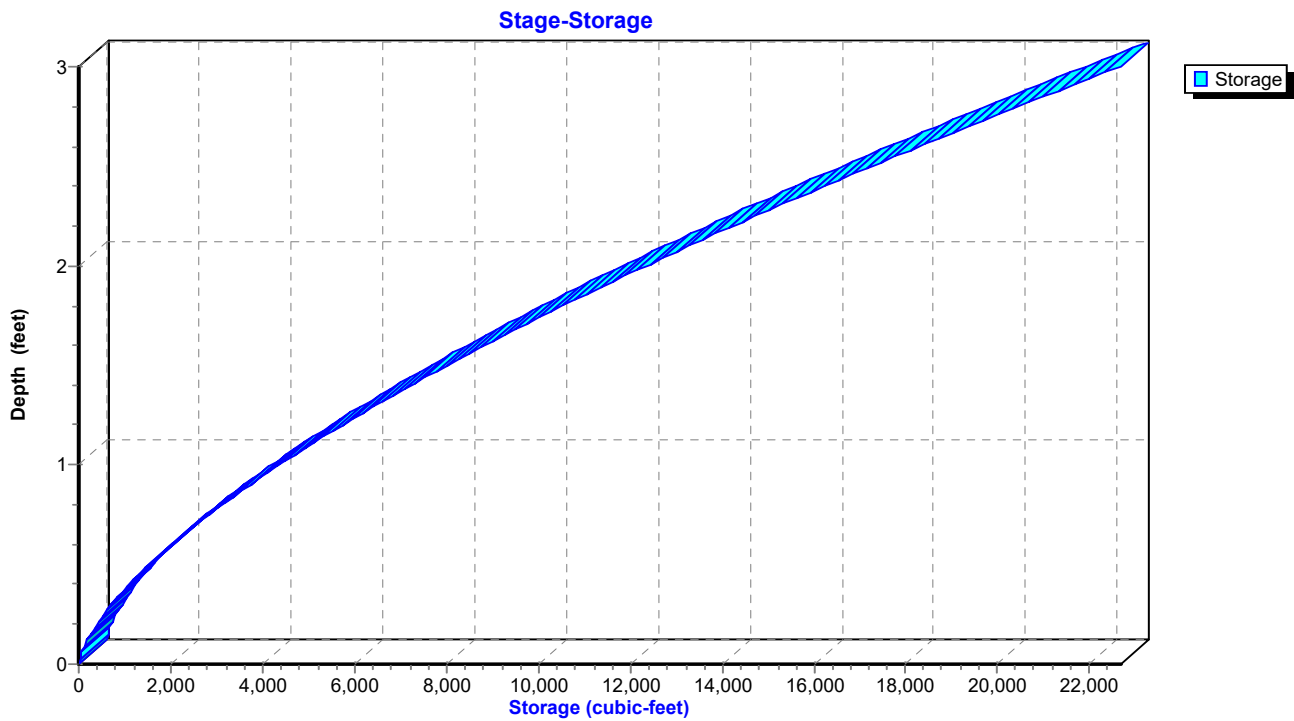

Hydrograph for Reach R1: Drainage Easement

Time (hours)	Inflow (cfs)	Storage (cubic-feet)	Elevation (feet)	Outflow (cfs)
0.05	0.00	0	780.00	0.00
5.05	0.00	0	780.00	0.00
10.05	0.05	45	780.05	0.01
15.05	10.06	4,321	780.99	10.48
20.05	4.66	2,473	780.68	4.79
25.05	2.32	1,491	780.49	2.34
30.05	2.15	1,409	780.47	2.16
35.05	1.96	1,323	780.45	1.97
40.05	1.76	1,224	780.43	1.77
45.05	1.53	1,109	780.40	1.54
50.05	1.27	973	780.37	1.28
55.05	0.98	813	780.33	0.99
60.05	0.67	623	780.27	0.68
65.05	0.31	377	780.20	0.34
70.05	0.10	169	780.11	0.11
75.05	0.05	108	780.08	0.06
80.05	0.03	69	780.06	0.03
85.05	0.01	42	780.04	0.02
90.05	0.01	27	780.03	0.01
95.05	0.00	17	780.02	0.00
100.05	0.00	9	780.01	0.00
105.05	0.00	5	780.01	0.00
110.05	0.00	3	780.00	0.00
115.05	0.00	1	780.00	0.00
120.05	0.00	1	780.00	0.00
125.05	0.00	0	780.00	0.00
130.05	0.00	0	780.00	0.00
135.05	0.00	0	780.00	0.00
140.05	0.00	0	780.00	0.00
145.05	0.00	0	780.00	0.00
150.05	0.00	0	780.00	0.00
155.05	0.00	0	780.00	0.00
160.05	0.00	0	780.00	0.00
165.05	0.00	0	780.00	0.00

Stage-Discharge for Reach R1: Drainage Easement

Elevation (feet)	Velocity (ft/sec)	Discharge (cfs)	Elevation (feet)	Velocity (ft/sec)	Discharge (cfs)	Elevation (feet)	Velocity (ft/sec)	Discharge (cfs)
780.00	0.00	0.00	781.04	4.61	11.31	782.08	6.74	46.71
780.02	0.32	0.00	781.06	4.66	11.76	782.10	6.78	47.62
780.04	0.58	0.01	781.08	4.71	12.22	782.12	6.81	48.54
780.06	0.77	0.03	781.10	4.76	12.70	782.14	6.84	49.47
780.08	0.93	0.05	781.12	4.81	13.18	782.16	6.88	50.41
780.10	1.07	0.08	781.14	4.86	13.66	782.18	6.91	51.36
780.12	1.21	0.12	781.16	4.91	14.17	782.20	6.94	52.31
780.14	1.34	0.16	781.18	4.96	14.67	782.22	6.97	53.28
780.16	1.46	0.22	781.20	5.00	15.19	782.24	7.01	54.25
780.18	1.58	0.28	781.22	5.05	15.72	782.26	7.04	55.23
780.20	1.69	0.35	781.24	5.10	16.25	782.28	7.07	56.22
780.22	1.79	0.43	781.26	5.14	16.80	782.30	7.10	57.22
780.24	1.89	0.51	781.28	5.19	17.35	782.32	7.13	58.23
780.26	1.99	0.61	781.30	5.23	17.91	782.34	7.17	59.24
780.28	2.09	0.72	781.32	5.28	18.48	782.36	7.20	60.27
780.30	2.18	0.83	781.34	5.32	19.06	782.38	7.23	61.30
780.32	2.27	0.95	781.36	5.36	19.65	782.40	7.26	62.34
780.34	2.36	1.08	781.38	5.41	20.25	782.42	7.29	63.39
780.36	2.44	1.22	781.40	5.45	20.86	782.44	7.32	64.45
780.38	2.53	1.37	781.42	5.49	21.47	782.46	7.35	65.51
780.40	2.61	1.53	781.44	5.54	22.09	782.48	7.38	66.59
780.42	2.69	1.69	781.46	5.58	22.73	782.50	7.41	67.67
780.44	2.77	1.87	781.48	5.62	23.37	782.52	7.44	68.76
780.46	2.84	2.05	781.50	5.66	24.02	782.54	7.47	69.87
780.48	2.92	2.24	781.52	5.70	24.68	782.56	7.50	70.97
780.50	2.99	2.45	781.54	5.74	25.35	782.58	7.53	72.09
780.52	3.07	2.66	781.56	5.78	26.02	782.60	7.56	73.22
780.54	3.14	2.87	781.58	5.82	26.71	782.62	7.59	74.35
780.56	3.21	3.11	781.60	5.86	27.41	782.64	7.62	75.49
780.58	3.28	3.34	781.62	5.90	28.11	782.66	7.65	76.65
780.60	3.34	3.59	781.64	5.94	28.82	782.68	7.68	77.80
780.62	3.41	3.85	781.66	5.98	29.54	782.70	7.71	78.97
780.64	3.47	4.11	781.68	6.02	30.27	782.72	7.74	80.15
780.66	3.54	4.38	781.70	6.06	31.01	782.74	7.76	81.33
780.68	3.60	4.67	781.72	6.10	31.76	782.76	7.79	82.52
780.70	3.66	4.96	781.74	6.13	32.52	782.78	7.82	83.73
780.72	3.73	5.26	781.76	6.17	33.28	782.80	7.85	84.94
780.74	3.79	5.57	781.78	6.21	34.06	782.82	7.88	86.15
780.76	3.85	5.89	781.80	6.25	34.84	782.84	7.91	87.38
780.78	3.91	6.22	781.82	6.28	35.63	782.86	7.93	88.62
780.80	3.97	6.55	781.84	6.32	36.43	782.88	7.96	89.86
780.82	4.02	6.90	781.86	6.36	37.24	782.90	7.99	91.11
780.84	4.08	7.25	781.88	6.39	38.06	782.92	8.02	92.37
780.86	4.14	7.62	781.90	6.43	38.88	782.94	8.04	93.64
780.88	4.19	7.99	781.92	6.46	39.72	782.96	8.07	94.92
780.90	4.25	8.37	781.94	6.50	40.56	782.98	8.10	96.20
780.92	4.30	8.77	781.96	6.53	41.41	783.00	8.12	97.49
780.94	4.35	9.17	781.98	6.57	42.27			
780.96	4.41	9.58	782.00	6.60	43.14			
780.98	4.46	10.00	782.02	6.64	44.02			
781.00	4.51	10.42	782.04	6.67	44.91			
781.02	4.56	10.86	782.06	6.71	45.80			

Stage-Area-Storage for Reach R1: Drainage Easement

Elevation (feet)	End-Area (sq-ft)	Storage (cubic-feet)	Elevation (feet)	End-Area (sq-ft)	Storage (cubic-feet)
780.00	0.0	0	782.60	9.7	18,299
780.05	0.0	50	782.65	10.0	18,829
780.10	0.1	139	782.70	10.2	19,365
780.15	0.1	254	782.75	10.5	19,905
780.20	0.2	391	782.80	10.8	20,450
780.25	0.3	546	782.85	11.1	21,000
780.30	0.4	717	782.90	11.4	21,556
780.35	0.5	904	782.95	11.7	22,116
780.40	0.6	1,105	783.00	12.0	22,680
780.45	0.7	1,318			
780.50	0.8	1,544			
780.55	0.9	1,781			
780.60	1.1	2,029			
780.65	1.2	2,288			
780.70	1.4	2,557			
780.75	1.5	2,835			
780.80	1.7	3,124			
780.85	1.8	3,421			
780.90	2.0	3,727			
780.95	2.1	4,042			
781.00	2.3	4,365			
781.05	2.5	4,696			
781.10	2.7	5,036			
781.15	2.8	5,383			
781.20	3.0	5,738			
781.25	3.2	6,100			
781.30	3.4	6,470			
781.35	3.6	6,846			
781.40	3.8	7,231			
781.45	4.0	7,621			
781.50	4.2	8,019			
781.55	4.5	8,423			
781.60	4.7	8,834			
781.65	4.9	9,251			
781.70	5.1	9,675			
781.75	5.3	10,105			
781.80	5.6	10,541			
781.85	5.8	10,983			
781.90	6.0	11,431			
781.95	6.3	11,885			
782.00	6.5	12,346			
782.05	6.8	12,811			
782.10	7.0	13,283			
782.15	7.3	13,760			
782.20	7.5	14,243			
782.25	7.8	14,731			
782.30	8.1	15,225			
782.35	8.3	15,724			
782.40	8.6	16,228			
782.45	8.9	16,738			
782.50	9.1	17,253			
782.55	9.4	17,773			

Summary for Pond P1: Infiltration Area

Inflow Area = 6.411 ac, 0.00% Impervious, Inflow Depth = 0.74" for 25-yr event
 Inflow = 5.67 cfs @ 12.05 hrs, Volume= 0.398 af
 Outflow = 0.14 cfs @ 24.03 hrs, Volume= 0.398 af, Atten= 98%, Lag= 718.8 min
 Discarded = 0.14 cfs @ 24.03 hrs, Volume= 0.398 af

Routing by Stor-Ind method, Time Span= 0.05-168.00 hrs, dt= 0.05 hrs
 Peak Elev= 855.99' @ 24.03 hrs Surf.Area= 11,337 sf Storage= 11,177 cf

Plug-Flow detention time= 855.0 min calculated for 0.397 af (100% of inflow)
 Center-of-Mass det. time= 855.2 min (1,759.6 - 904.4)

Volume	Invert	Avail.Storage	Storage Description
#1	855.00'	22,674 cf	Custom Stage Data (Prismatic) Listed below (Recalc)

Elevation (feet)	Surf.Area (sq-ft)	Inc.Store (cubic-feet)	Cum.Store (cubic-feet)
855.00	11,337	0	0
856.00	11,337	11,337	11,337
857.00	11,337	11,337	22,674

Device	Routing	Invert	Outlet Devices
#1	Discarded	855.00'	0.500 in/hr Exfiltration over Surface area Conductivity to Groundwater Elevation = 840.00'

Discarded OutFlow Max=0.14 cfs @ 24.03 hrs HW=855.99' (Free Discharge)

↑**1=Exfiltration** (Controls 0.14 cfs)

Pond P1: Infiltration Area

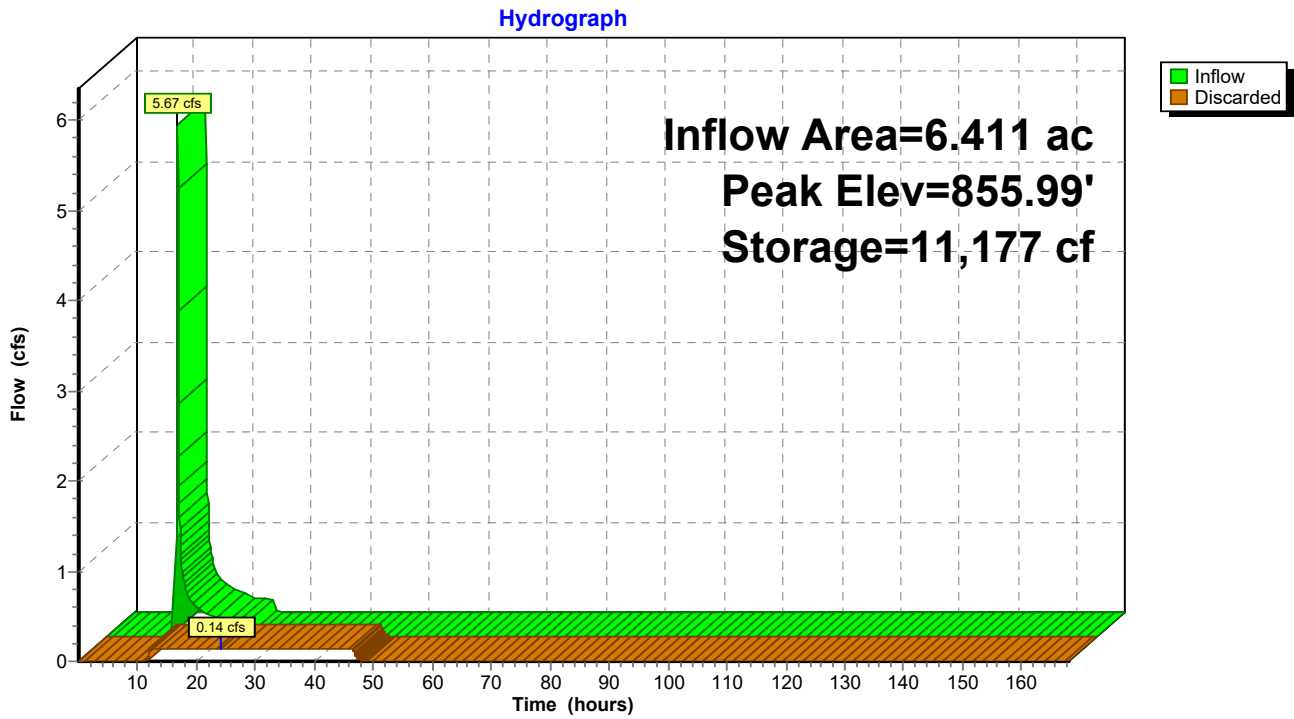

Pond P1: Infiltration Area

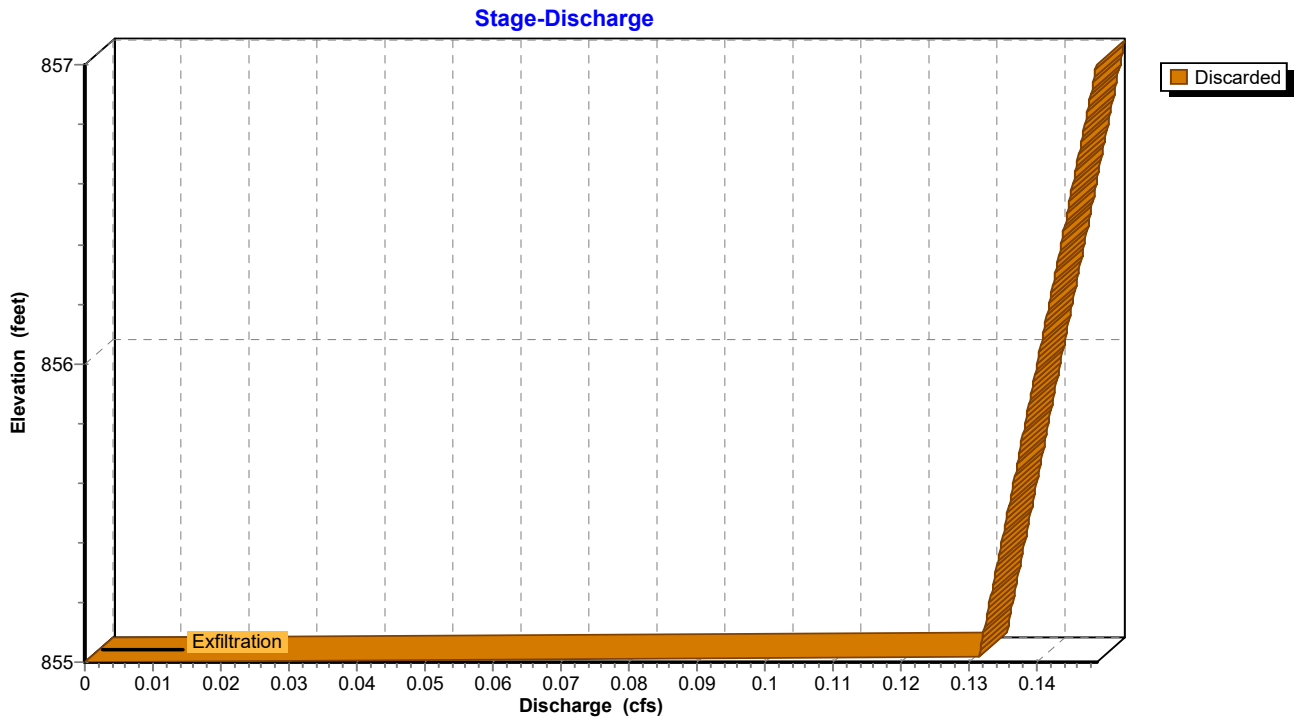

Pond P1: Infiltration Area

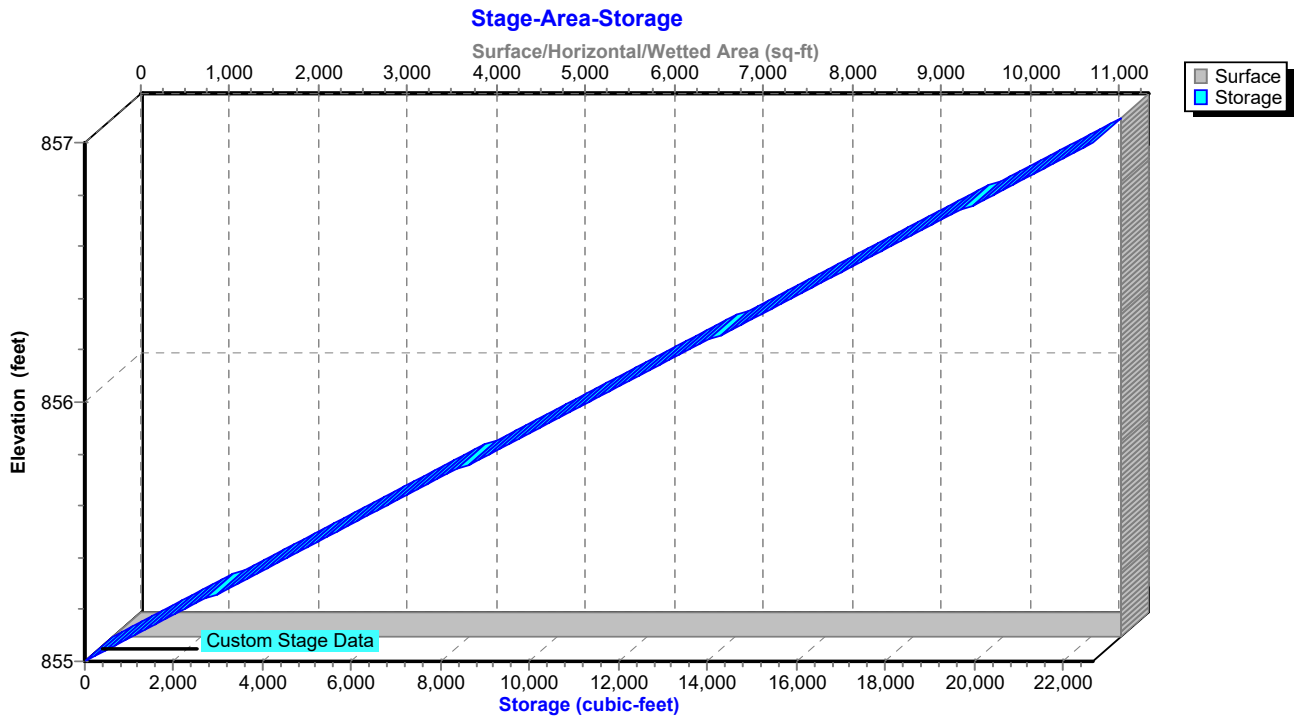

Hydrograph for Pond P1: Infiltration Area

Time (hours)	Inflow (cfs)	Storage (cubic-feet)	Elevation (feet)	Discarded (cfs)
0.05	0.00	0	855.00	0.00
5.05	0.00	0	855.00	0.00
10.05	0.00	0	855.00	0.00
15.05	0.34	9,272	855.82	0.14
20.05	0.16	10,988	855.97	0.14
25.05	0.00	10,738	855.95	0.14
30.05	0.00	8,244	855.73	0.14
35.05	0.00	5,785	855.51	0.14
40.05	0.00	3,359	855.30	0.13
45.05	0.00	967	855.09	0.13
50.05	0.00	0	855.00	0.00
55.05	0.00	0	855.00	0.00
60.05	0.00	0	855.00	0.00
65.05	0.00	0	855.00	0.00
70.05	0.00	0	855.00	0.00
75.05	0.00	0	855.00	0.00
80.05	0.00	0	855.00	0.00
85.05	0.00	0	855.00	0.00
90.05	0.00	0	855.00	0.00
95.05	0.00	0	855.00	0.00
100.05	0.00	0	855.00	0.00
105.05	0.00	0	855.00	0.00
110.05	0.00	0	855.00	0.00
115.05	0.00	0	855.00	0.00
120.05	0.00	0	855.00	0.00
125.05	0.00	0	855.00	0.00
130.05	0.00	0	855.00	0.00
135.05	0.00	0	855.00	0.00
140.05	0.00	0	855.00	0.00
145.05	0.00	0	855.00	0.00
150.05	0.00	0	855.00	0.00
155.05	0.00	0	855.00	0.00
160.05	0.00	0	855.00	0.00
165.05	0.00	0	855.00	0.00

Stage-Discharge for Pond P1: Infiltration Area

Elevation (feet)	Discarded (cfs)	Elevation (feet)	Discarded (cfs)	Elevation (feet)	Discarded (cfs)	Elevation (feet)	Discarded (cfs)
855.00	0.00	855.52	0.14	856.04	0.14	856.56	0.14
855.01	0.13	855.53	0.14	856.05	0.14	856.57	0.14
855.02	0.13	855.54	0.14	856.06	0.14	856.58	0.15
855.03	0.13	855.55	0.14	856.07	0.14	856.59	0.15
855.04	0.13	855.56	0.14	856.08	0.14	856.60	0.15
855.05	0.13	855.57	0.14	856.09	0.14	856.61	0.15
855.06	0.13	855.58	0.14	856.10	0.14	856.62	0.15
855.07	0.13	855.59	0.14	856.11	0.14	856.63	0.15
855.08	0.13	855.60	0.14	856.12	0.14	856.64	0.15
855.09	0.13	855.61	0.14	856.13	0.14	856.65	0.15
855.10	0.13	855.62	0.14	856.14	0.14	856.66	0.15
855.11	0.13	855.63	0.14	856.15	0.14	856.67	0.15
855.12	0.13	855.64	0.14	856.16	0.14	856.68	0.15
855.13	0.13	855.65	0.14	856.17	0.14	856.69	0.15
855.14	0.13	855.66	0.14	856.18	0.14	856.70	0.15
855.15	0.13	855.67	0.14	856.19	0.14	856.71	0.15
855.16	0.13	855.68	0.14	856.20	0.14	856.72	0.15
855.17	0.13	855.69	0.14	856.21	0.14	856.73	0.15
855.18	0.13	855.70	0.14	856.22	0.14	856.74	0.15
855.19	0.13	855.71	0.14	856.23	0.14	856.75	0.15
855.20	0.13	855.72	0.14	856.24	0.14	856.76	0.15
855.21	0.13	855.73	0.14	856.25	0.14	856.77	0.15
855.22	0.13	855.74	0.14	856.26	0.14	856.78	0.15
855.23	0.13	855.75	0.14	856.27	0.14	856.79	0.15
855.24	0.13	855.76	0.14	856.28	0.14	856.80	0.15
855.25	0.13	855.77	0.14	856.29	0.14	856.81	0.15
855.26	0.13	855.78	0.14	856.30	0.14	856.82	0.15
855.27	0.13	855.79	0.14	856.31	0.14	856.83	0.15
855.28	0.13	855.80	0.14	856.32	0.14	856.84	0.15
855.29	0.13	855.81	0.14	856.33	0.14	856.85	0.15
855.30	0.13	855.82	0.14	856.34	0.14	856.86	0.15
855.31	0.13	855.83	0.14	856.35	0.14	856.87	0.15
855.32	0.13	855.84	0.14	856.36	0.14	856.88	0.15
855.33	0.13	855.85	0.14	856.37	0.14	856.89	0.15
855.34	0.13	855.86	0.14	856.38	0.14	856.90	0.15
855.35	0.13	855.87	0.14	856.39	0.14	856.91	0.15
855.36	0.13	855.88	0.14	856.40	0.14	856.92	0.15
855.37	0.13	855.89	0.14	856.41	0.14	856.93	0.15
855.38	0.13	855.90	0.14	856.42	0.14	856.94	0.15
855.39	0.13	855.91	0.14	856.43	0.14	856.95	0.15
855.40	0.13	855.92	0.14	856.44	0.14	856.96	0.15
855.41	0.13	855.93	0.14	856.45	0.14	856.97	0.15
855.42	0.13	855.94	0.14	856.46	0.14	856.98	0.15
855.43	0.13	855.95	0.14	856.47	0.14	856.99	0.15
855.44	0.14	855.96	0.14	856.48	0.14	857.00	0.15
855.45	0.14	855.97	0.14	856.49	0.14		
855.46	0.14	855.98	0.14	856.50	0.14		
855.47	0.14	855.99	0.14	856.51	0.14		
855.48	0.14	856.00	0.14	856.52	0.14		
855.49	0.14	856.01	0.14	856.53	0.14		
855.50	0.14	856.02	0.14	856.54	0.14		
855.51	0.14	856.03	0.14	856.55	0.14		

Stage-Area-Storage for Pond P1: Infiltration Area

Elevation (feet)	Surface (sq-ft)	Storage (cubic-feet)	Elevation (feet)	Surface (sq-ft)	Storage (cubic-feet)
855.00	11,337	0	856.04	11,337	11,790
855.02	11,337	227	856.06	11,337	12,017
855.04	11,337	453	856.08	11,337	12,244
855.06	11,337	680	856.10	11,337	12,471
855.08	11,337	907	856.12	11,337	12,697
855.10	11,337	1,134	856.14	11,337	12,924
855.12	11,337	1,360	856.16	11,337	13,151
855.14	11,337	1,587	856.18	11,337	13,378
855.16	11,337	1,814	856.20	11,337	13,604
855.18	11,337	2,041	856.22	11,337	13,831
855.20	11,337	2,267	856.24	11,337	14,058
855.22	11,337	2,494	856.26	11,337	14,285
855.24	11,337	2,721	856.28	11,337	14,511
855.26	11,337	2,948	856.30	11,337	14,738
855.28	11,337	3,174	856.32	11,337	14,965
855.30	11,337	3,401	856.34	11,337	15,192
855.32	11,337	3,628	856.36	11,337	15,418
855.34	11,337	3,855	856.38	11,337	15,645
855.36	11,337	4,081	856.40	11,337	15,872
855.38	11,337	4,308	856.42	11,337	16,099
855.40	11,337	4,535	856.44	11,337	16,325
855.42	11,337	4,762	856.46	11,337	16,552
855.44	11,337	4,988	856.48	11,337	16,779
855.46	11,337	5,215	856.50	11,337	17,006
855.48	11,337	5,442	856.52	11,337	17,232
855.50	11,337	5,669	856.54	11,337	17,459
855.52	11,337	5,895	856.56	11,337	17,686
855.54	11,337	6,122	856.58	11,337	17,912
855.56	11,337	6,349	856.60	11,337	18,139
855.58	11,337	6,575	856.62	11,337	18,366
855.60	11,337	6,802	856.64	11,337	18,593
855.62	11,337	7,029	856.66	11,337	18,819
855.64	11,337	7,256	856.68	11,337	19,046
855.66	11,337	7,482	856.70	11,337	19,273
855.68	11,337	7,709	856.72	11,337	19,500
855.70	11,337	7,936	856.74	11,337	19,726
855.72	11,337	8,163	856.76	11,337	19,953
855.74	11,337	8,389	856.78	11,337	20,180
855.76	11,337	8,616	856.80	11,337	20,407
855.78	11,337	8,843	856.82	11,337	20,633
855.80	11,337	9,070	856.84	11,337	20,860
855.82	11,337	9,296	856.86	11,337	21,087
855.84	11,337	9,523	856.88	11,337	21,314
855.86	11,337	9,750	856.90	11,337	21,540
855.88	11,337	9,977	856.92	11,337	21,767
855.90	11,337	10,203	856.94	11,337	21,994
855.92	11,337	10,430	856.96	11,337	22,221
855.94	11,337	10,657	856.98	11,337	22,447
855.96	11,337	10,884	857.00	11,337	22,674
855.98	11,337	11,110			
856.00	11,337	11,337			
856.02	11,337	11,564			

Summary for Pond P3: Infiltration Area

Inflow Area = 5.511 ac, 0.00% Impervious, Inflow Depth = 0.20" for 25-yr event
 Inflow = 0.22 cfs @ 12.39 hrs, Volume= 0.093 af
 Outflow = 0.12 cfs @ 14.01 hrs, Volume= 0.093 af, Atten= 44%, Lag= 97.5 min
 Discarded = 0.12 cfs @ 14.01 hrs, Volume= 0.093 af

Routing by Stor-Ind method, Time Span= 0.05-168.00 hrs, dt= 0.05 hrs
 Peak Elev= 855.04' @ 14.01 hrs Surf.Area= 10,679 sf Storage= 399 cf

Plug-Flow detention time= 36.5 min calculated for 0.093 af (100% of inflow)
 Center-of-Mass det. time= 36.4 min (1,045.2 - 1,008.8)

Volume	Invert	Avail.Storage	Storage Description
#1	855.00'	21,358 cf	Custom Stage Data (Prismatic) Listed below (Recalc)

Elevation (feet)	Surf.Area (sq-ft)	Inc.Store (cubic-feet)	Cum.Store (cubic-feet)
855.00	10,679	0	0
856.00	10,679	10,679	10,679
857.00	10,679	10,679	21,358

Device	Routing	Invert	Outlet Devices
#1	Discarded	855.00'	0.500 in/hr Exfiltration over Surface area Conductivity to Groundwater Elevation = 840.00'

Discarded OutFlow Max=0.12 cfs @ 14.01 hrs HW=855.04' (Free Discharge)

↑1=Exfiltration (Controls 0.12 cfs)

Pond P3: Infiltration Area

Hydrograph

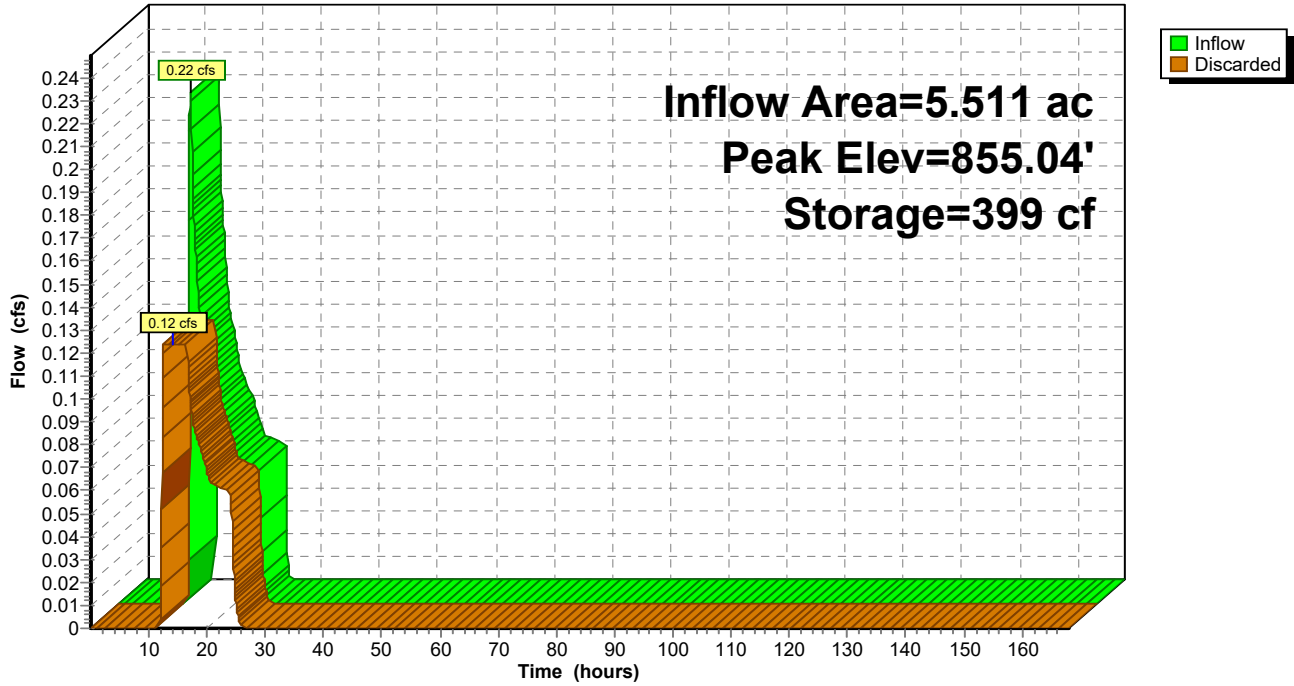

Pond P3: Infiltration Area

Stage-Discharge

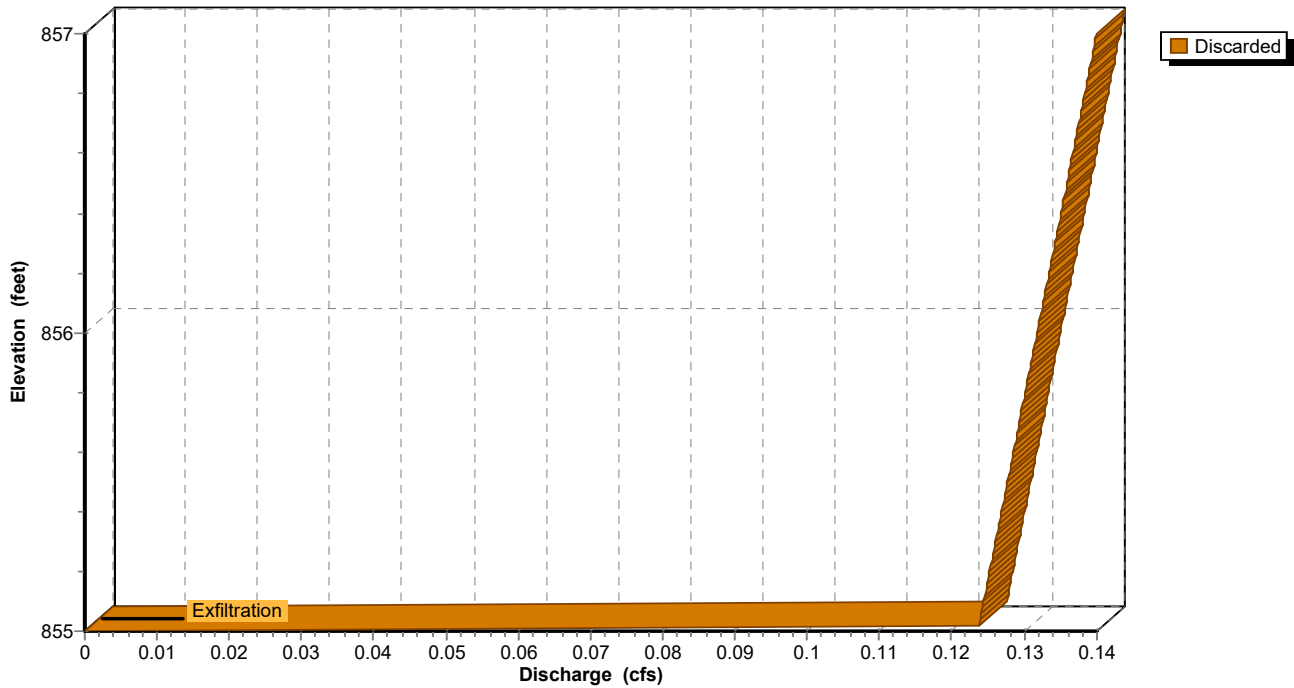

Pond P3: Infiltration Area

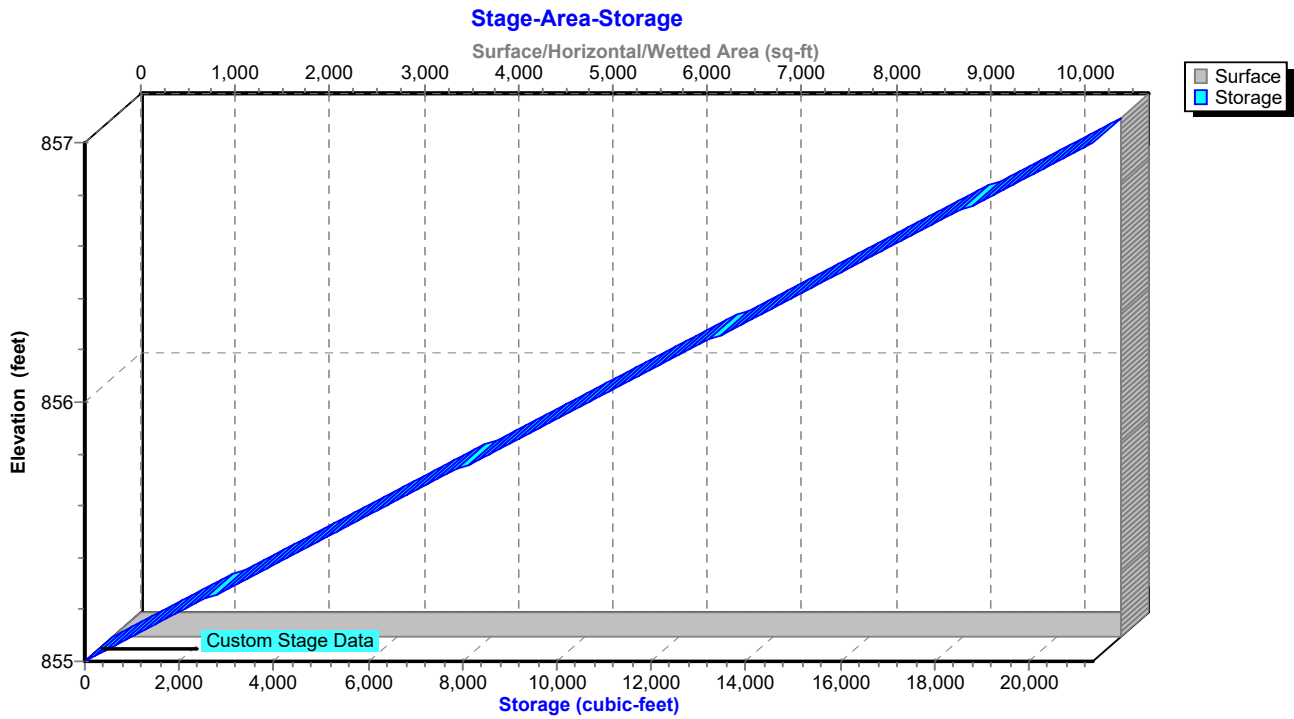

Hydrograph for Pond P3: Infiltration Area

Time (hours)	Inflow (cfs)	Storage (cubic-feet)	Elevation (feet)	Discarded (cfs)
0.05	0.00	0	855.00	0.00
5.05	0.00	0	855.00	0.00
10.05	0.00	0	855.00	0.00
15.05	0.11	365	855.03	0.12
20.05	0.06	117	855.01	0.07
25.05	0.00	17	855.00	0.01
30.05	0.00	0	855.00	0.00
35.05	0.00	0	855.00	0.00
40.05	0.00	0	855.00	0.00
45.05	0.00	0	855.00	0.00
50.05	0.00	0	855.00	0.00
55.05	0.00	0	855.00	0.00
60.05	0.00	0	855.00	0.00
65.05	0.00	0	855.00	0.00
70.05	0.00	0	855.00	0.00
75.05	0.00	0	855.00	0.00
80.05	0.00	0	855.00	0.00
85.05	0.00	0	855.00	0.00
90.05	0.00	0	855.00	0.00
95.05	0.00	0	855.00	0.00
100.05	0.00	0	855.00	0.00
105.05	0.00	0	855.00	0.00
110.05	0.00	0	855.00	0.00
115.05	0.00	0	855.00	0.00
120.05	0.00	0	855.00	0.00
125.05	0.00	0	855.00	0.00
130.05	0.00	0	855.00	0.00
135.05	0.00	0	855.00	0.00
140.05	0.00	0	855.00	0.00
145.05	0.00	0	855.00	0.00
150.05	0.00	0	855.00	0.00
155.05	0.00	0	855.00	0.00
160.05	0.00	0	855.00	0.00
165.05	0.00	0	855.00	0.00

Stage-Discharge for Pond P3: Infiltration Area

Elevation (feet)	Discarded (cfs)	Elevation (feet)	Discarded (cfs)	Elevation (feet)	Discarded (cfs)	Elevation (feet)	Discarded (cfs)
855.00	0.00	855.52	0.13	856.04	0.13	856.56	0.14
855.01	0.12	855.53	0.13	856.05	0.13	856.57	0.14
855.02	0.12	855.54	0.13	856.06	0.13	856.58	0.14
855.03	0.12	855.55	0.13	856.07	0.13	856.59	0.14
855.04	0.12	855.56	0.13	856.08	0.13	856.60	0.14
855.05	0.12	855.57	0.13	856.09	0.13	856.61	0.14
855.06	0.12	855.58	0.13	856.10	0.13	856.62	0.14
855.07	0.12	855.59	0.13	856.11	0.13	856.63	0.14
855.08	0.12	855.60	0.13	856.12	0.13	856.64	0.14
855.09	0.12	855.61	0.13	856.13	0.13	856.65	0.14
855.10	0.12	855.62	0.13	856.14	0.13	856.66	0.14
855.11	0.12	855.63	0.13	856.15	0.13	856.67	0.14
855.12	0.12	855.64	0.13	856.16	0.13	856.68	0.14
855.13	0.12	855.65	0.13	856.17	0.13	856.69	0.14
855.14	0.12	855.66	0.13	856.18	0.13	856.70	0.14
855.15	0.12	855.67	0.13	856.19	0.13	856.71	0.14
855.16	0.12	855.68	0.13	856.20	0.13	856.72	0.14
855.17	0.13	855.69	0.13	856.21	0.13	856.73	0.14
855.18	0.13	855.70	0.13	856.22	0.13	856.74	0.14
855.19	0.13	855.71	0.13	856.23	0.13	856.75	0.14
855.20	0.13	855.72	0.13	856.24	0.13	856.76	0.14
855.21	0.13	855.73	0.13	856.25	0.13	856.77	0.14
855.22	0.13	855.74	0.13	856.26	0.13	856.78	0.14
855.23	0.13	855.75	0.13	856.27	0.13	856.79	0.14
855.24	0.13	855.76	0.13	856.28	0.13	856.80	0.14
855.25	0.13	855.77	0.13	856.29	0.13	856.81	0.14
855.26	0.13	855.78	0.13	856.30	0.13	856.82	0.14
855.27	0.13	855.79	0.13	856.31	0.13	856.83	0.14
855.28	0.13	855.80	0.13	856.32	0.13	856.84	0.14
855.29	0.13	855.81	0.13	856.33	0.13	856.85	0.14
855.30	0.13	855.82	0.13	856.34	0.13	856.86	0.14
855.31	0.13	855.83	0.13	856.35	0.13	856.87	0.14
855.32	0.13	855.84	0.13	856.36	0.13	856.88	0.14
855.33	0.13	855.85	0.13	856.37	0.13	856.89	0.14
855.34	0.13	855.86	0.13	856.38	0.13	856.90	0.14
855.35	0.13	855.87	0.13	856.39	0.14	856.91	0.14
855.36	0.13	855.88	0.13	856.40	0.14	856.92	0.14
855.37	0.13	855.89	0.13	856.41	0.14	856.93	0.14
855.38	0.13	855.90	0.13	856.42	0.14	856.94	0.14
855.39	0.13	855.91	0.13	856.43	0.14	856.95	0.14
855.40	0.13	855.92	0.13	856.44	0.14	856.96	0.14
855.41	0.13	855.93	0.13	856.45	0.14	856.97	0.14
855.42	0.13	855.94	0.13	856.46	0.14	856.98	0.14
855.43	0.13	855.95	0.13	856.47	0.14	856.99	0.14
855.44	0.13	855.96	0.13	856.48	0.14	857.00	0.14
855.45	0.13	855.97	0.13	856.49	0.14		
855.46	0.13	855.98	0.13	856.50	0.14		
855.47	0.13	855.99	0.13	856.51	0.14		
855.48	0.13	856.00	0.13	856.52	0.14		
855.49	0.13	856.01	0.13	856.53	0.14		
855.50	0.13	856.02	0.13	856.54	0.14		
855.51	0.13	856.03	0.13	856.55	0.14		

Stage-Area-Storage for Pond P3: Infiltration Area

Elevation (feet)	Surface (sq-ft)	Storage (cubic-feet)	Elevation (feet)	Surface (sq-ft)	Storage (cubic-feet)
855.00	10,679	0	856.04	10,679	11,106
855.02	10,679	214	856.06	10,679	11,320
855.04	10,679	427	856.08	10,679	11,533
855.06	10,679	641	856.10	10,679	11,747
855.08	10,679	854	856.12	10,679	11,960
855.10	10,679	1,068	856.14	10,679	12,174
855.12	10,679	1,281	856.16	10,679	12,388
855.14	10,679	1,495	856.18	10,679	12,601
855.16	10,679	1,709	856.20	10,679	12,815
855.18	10,679	1,922	856.22	10,679	13,028
855.20	10,679	2,136	856.24	10,679	13,242
855.22	10,679	2,349	856.26	10,679	13,456
855.24	10,679	2,563	856.28	10,679	13,669
855.26	10,679	2,777	856.30	10,679	13,883
855.28	10,679	2,990	856.32	10,679	14,096
855.30	10,679	3,204	856.34	10,679	14,310
855.32	10,679	3,417	856.36	10,679	14,523
855.34	10,679	3,631	856.38	10,679	14,737
855.36	10,679	3,844	856.40	10,679	14,951
855.38	10,679	4,058	856.42	10,679	15,164
855.40	10,679	4,272	856.44	10,679	15,378
855.42	10,679	4,485	856.46	10,679	15,591
855.44	10,679	4,699	856.48	10,679	15,805
855.46	10,679	4,912	856.50	10,679	16,019
855.48	10,679	5,126	856.52	10,679	16,232
855.50	10,679	5,340	856.54	10,679	16,446
855.52	10,679	5,553	856.56	10,679	16,659
855.54	10,679	5,767	856.58	10,679	16,873
855.56	10,679	5,980	856.60	10,679	17,086
855.58	10,679	6,194	856.62	10,679	17,300
855.60	10,679	6,407	856.64	10,679	17,514
855.62	10,679	6,621	856.66	10,679	17,727
855.64	10,679	6,835	856.68	10,679	17,941
855.66	10,679	7,048	856.70	10,679	18,154
855.68	10,679	7,262	856.72	10,679	18,368
855.70	10,679	7,475	856.74	10,679	18,581
855.72	10,679	7,689	856.76	10,679	18,795
855.74	10,679	7,902	856.78	10,679	19,009
855.76	10,679	8,116	856.80	10,679	19,222
855.78	10,679	8,330	856.82	10,679	19,436
855.80	10,679	8,543	856.84	10,679	19,649
855.82	10,679	8,757	856.86	10,679	19,863
855.84	10,679	8,970	856.88	10,679	20,077
855.86	10,679	9,184	856.90	10,679	20,290
855.88	10,679	9,398	856.92	10,679	20,504
855.90	10,679	9,611	856.94	10,679	20,717
855.92	10,679	9,825	856.96	10,679	20,931
855.94	10,679	10,038	856.98	10,679	21,144
855.96	10,679	10,252	857.00	10,679	21,358
855.98	10,679	10,465			
856.00	10,679	10,679			
856.02	10,679	10,893			

Summary for Pond P4: Mine Ponds

Inflow Area = 60.830 ac, 0.87% Impervious, Inflow Depth = 2.12" for 25-yr event
 Inflow = 115.55 cfs @ 12.23 hrs, Volume= 10.755 af
 Outflow = 18.63 cfs @ 13.06 hrs, Volume= 10.755 af, Atten= 84%, Lag= 49.9 min
 Primary = 18.63 cfs @ 13.06 hrs, Volume= 10.755 af

Routing by Stor-Ind method, Time Span= 0.05-168.00 hrs, dt= 0.05 hrs
 Starting Elev= 832.00' Surf.Area= 22,977 sf Storage= 61,614 cf
 Peak Elev= 838.78' @ 13.06 hrs Surf.Area= 53,083 sf Storage= 310,325 cf (248,711 cf above start)

Plug-Flow detention time= 1,030.6 min calculated for 9.340 af (87% of inflow)
 Center-of-Mass det. time= 830.1 min (1,683.3 - 853.1)

Volume	Invert	Avail.Storage	Storage Description
#1	826.00'	441,657 cf	Custom Stage Data (Prismatic) Listed below (Recalc)
Elevation (feet)	Surf.Area (sq-ft)	Inc.Store (cubic-feet)	Cum.Store (cubic-feet)
826.00	3,651	0	0
830.00	10,445	28,192	28,192
832.00	22,977	33,422	61,614
834.00	29,257	52,234	113,848
836.00	39,283	68,540	182,388
838.00	49,027	88,310	270,698
840.00	59,479	108,506	379,204
841.00	65,426	62,453	441,657

Device	Routing	Invert	Outlet Devices
#1	Primary	839.00'	8.0' long x 4.0' breadth Broad-Crested Rectangular Weir Head (feet) 0.20 0.40 0.60 0.80 1.00 1.20 1.40 1.60 1.80 2.00 2.50 3.00 3.50 4.00 4.50 5.00 5.50 Coef. (English) 2.38 2.54 2.69 2.68 2.67 2.67 2.65 2.66 2.66 2.68 2.72 2.73 2.76 2.79 2.88 3.07 3.32
#2	Device 5	838.50'	20.0' long Sharp-Crested Rectangular Weir 0 End Contraction(s)
#3	Device 5	838.20'	3.5' long x 0.30' rise Sharp-Crested Rectangular Weir X 2.00 2 End Contraction(s)
#4	Device 5	832.00'	3.0" Vert. Orifice/Grate X 4.00 C= 0.600
#5	Primary	832.00'	24.0" Round Culvert L= 118.0' CPP, square edge headwall, Ke= 0.500 Inlet / Outlet Invert= 832.00' / 831.00' S= 0.0085 '/' Cc= 0.900 n= 0.013, Flow Area= 3.14 sf

Primary OutFlow Max=18.49 cfs @ 13.06 hrs HW=838.78' (Free Discharge)
 1=Broad-Crested Rectangular Weir (Controls 0.00 cfs)
 5=Culvert (Passes 18.49 cfs of 35.15 cfs potential flow)
 2=Sharp-Crested Rectangular Weir (Weir Controls 9.48 cfs @ 1.72 fps)
 3=Sharp-Crested Rectangular Weir (Orifice Controls 6.57 cfs @ 3.18 fps)
 4=Orifice/Grate (Orifice Controls 2.44 cfs @ 12.42 fps)

Pond P4: Mine Ponds

Hydrograph

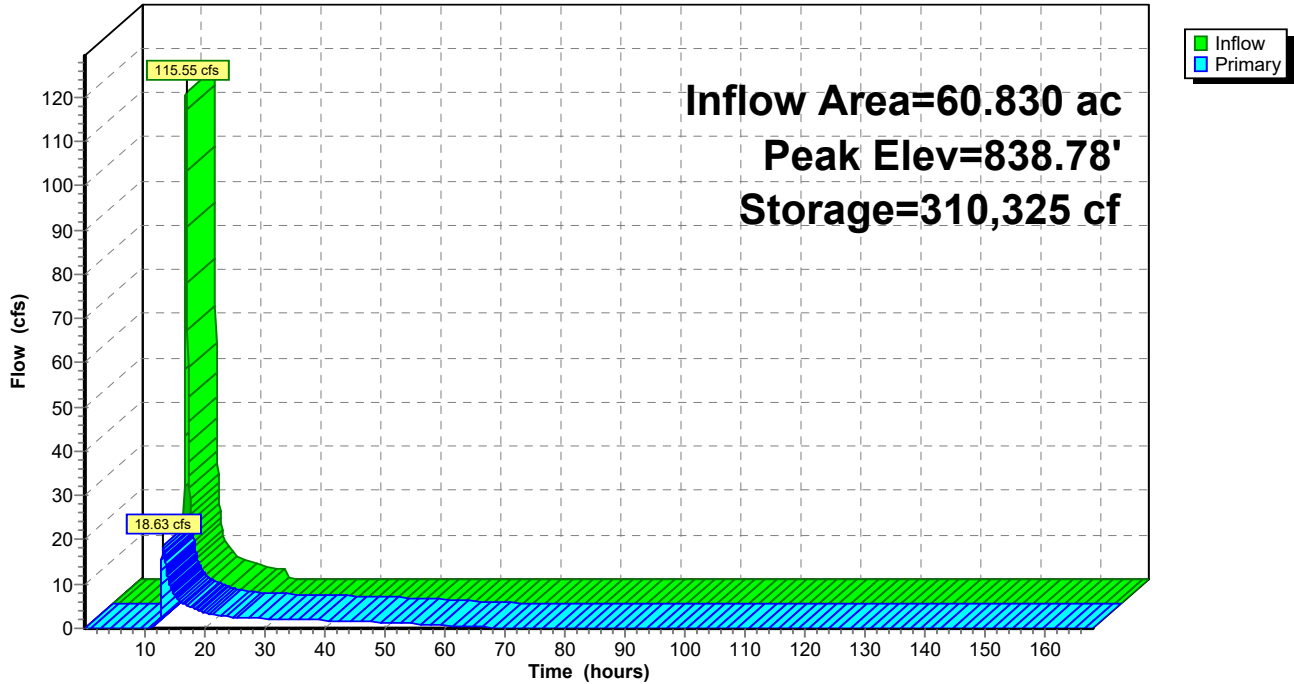

Pond P4: Mine Ponds

Stage-Discharge

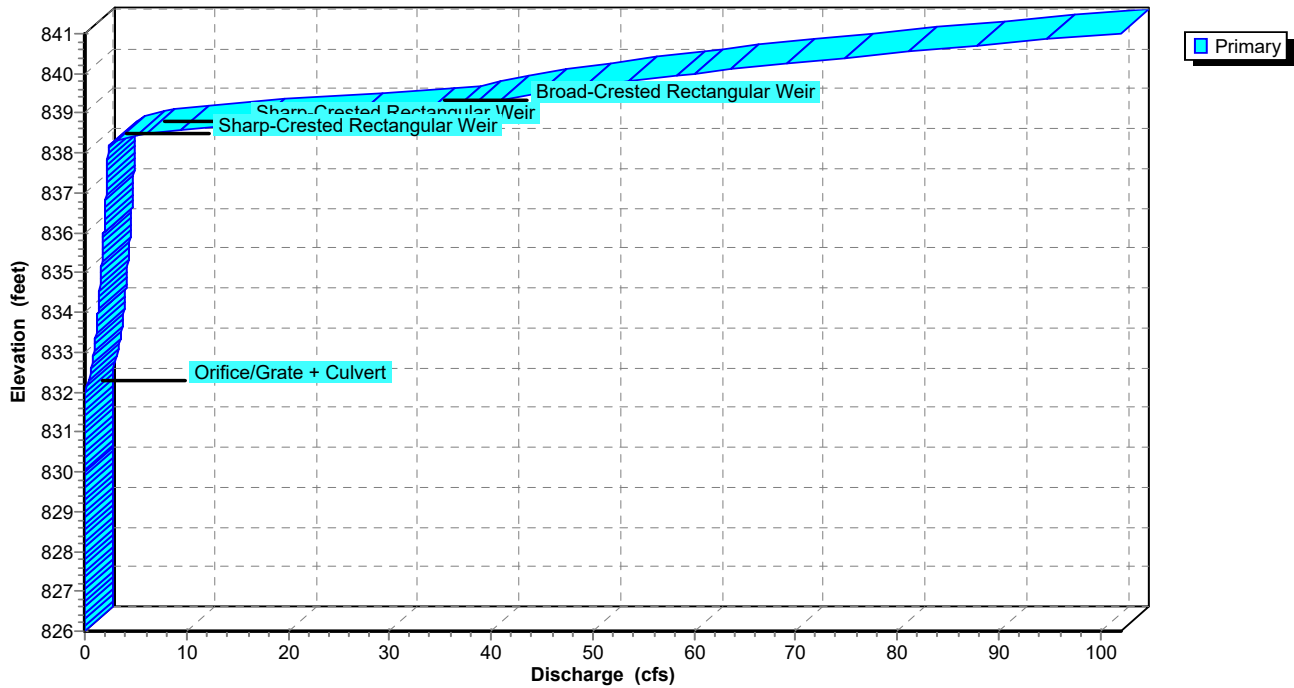

Pond P4: Mine Ponds

Stage-Area-Storage

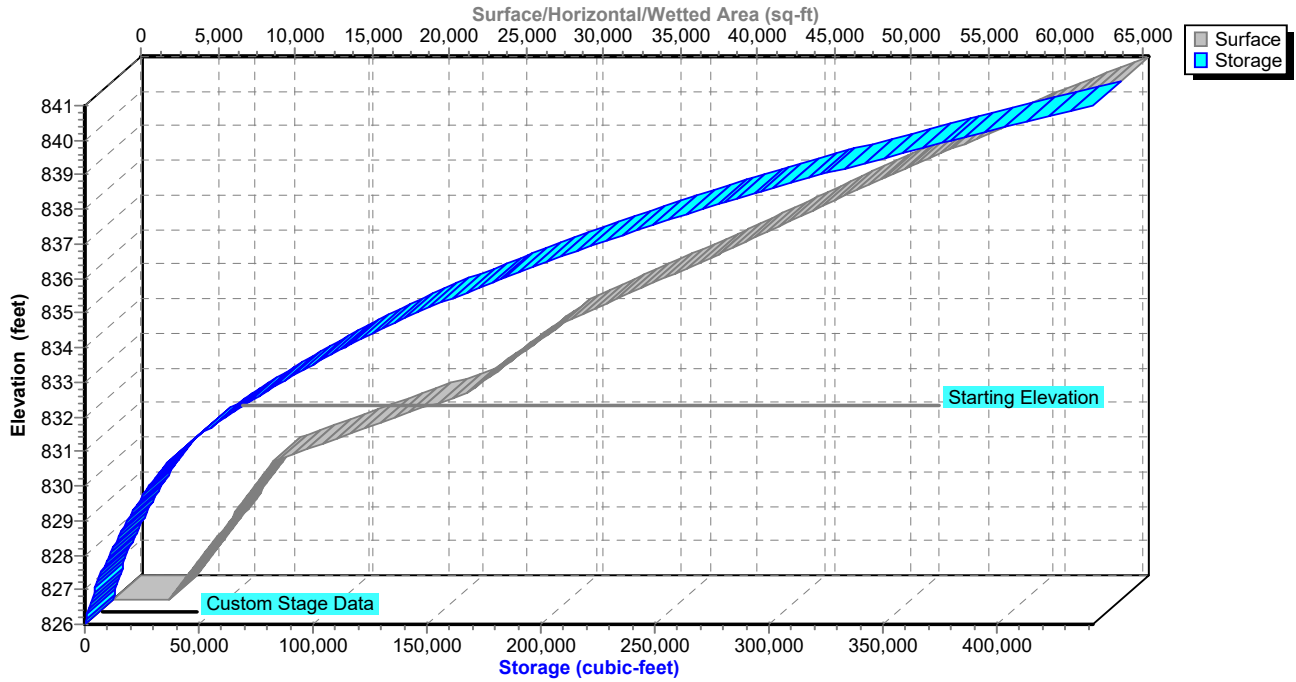

Hydrograph for Pond P4: Mine Ponds

Time (hours)	Inflow (cfs)	Storage (cubic-feet)	Elevation (feet)	Primary (cfs)
0.05	0.00	61,614	832.00	0.00
5.05	0.00	61,614	832.00	0.00
10.05	0.80	62,923	832.06	0.05
15.05	6.68	298,047	838.54	7.50
20.05	2.98	287,159	838.33	3.49
25.05	0.04	277,243	838.13	2.32
30.05	0.00	237,052	837.29	2.15
35.05	0.00	200,023	836.44	1.96
40.05	0.00	166,497	835.58	1.76
45.05	0.00	136,873	834.74	1.53
50.05	0.00	111,651	833.92	1.27
55.05	0.00	91,394	833.20	0.98
60.05	0.00	76,555	832.62	0.67
65.05	0.00	67,567	832.25	0.31
70.05	0.00	64,418	832.12	0.10
75.05	0.00	63,077	832.06	0.05
80.05	0.00	62,377	832.03	0.03
85.05	0.00	62,012	832.02	0.01
90.05	0.00	61,821	832.01	0.01
95.05	0.00	61,722	832.00	0.00
100.05	0.00	61,670	832.00	0.00
105.05	0.00	61,643	832.00	0.00
110.05	0.00	61,629	832.00	0.00
115.05	0.00	61,622	832.00	0.00
120.05	0.00	61,618	832.00	0.00
125.05	0.00	61,616	832.00	0.00
130.05	0.00	61,615	832.00	0.00
135.05	0.00	61,615	832.00	0.00
140.05	0.00	61,614	832.00	0.00
145.05	0.00	61,614	832.00	0.00
150.05	0.00	61,614	832.00	0.00
155.05	0.00	61,614	832.00	0.00
160.05	0.00	61,614	832.00	0.00
165.05	0.00	61,614	832.00	0.00

Stage-Discharge for Pond P4: Mine Ponds

Elevation (feet)	Primary (cfs)	Elevation (feet)	Primary (cfs)
826.00	0.00	833.80	1.22
826.15	0.00	833.95	1.28
826.30	0.00	834.10	1.33
826.45	0.00	834.25	1.38
826.60	0.00	834.40	1.43
826.75	0.00	834.55	1.47
826.90	0.00	834.70	1.52
827.05	0.00	834.85	1.56
827.20	0.00	835.00	1.60
827.35	0.00	835.15	1.64
827.50	0.00	835.30	1.68
827.65	0.00	835.45	1.72
827.80	0.00	835.60	1.76
827.95	0.00	835.75	1.80
828.10	0.00	835.90	1.84
828.25	0.00	836.05	1.87
828.40	0.00	836.20	1.91
828.55	0.00	836.35	1.94
828.70	0.00	836.50	1.98
828.85	0.00	836.65	2.01
829.00	0.00	836.80	2.04
829.15	0.00	836.95	2.08
829.30	0.00	837.10	2.11
829.45	0.00	837.25	2.14
829.60	0.00	837.40	2.17
829.75	0.00	837.55	2.20
829.90	0.00	837.70	2.23
830.05	0.00	837.85	2.26
830.20	0.00	838.00	2.29
830.35	0.00	838.15	2.32
830.50	0.00	838.30	3.07
830.65	0.00	838.45	5.20
830.80	0.00	838.60	9.45
830.95	0.00	838.75	16.97
831.10	0.00	838.90	26.49
831.25	0.00	839.05	36.19
831.40	0.00	839.20	38.13
831.55	0.00	839.35	41.00
831.70	0.00	839.50	44.69
831.85	0.00	839.65	48.99
832.00	0.00	839.80	53.48
832.15	0.13	839.95	58.36
832.30	0.40	840.10	63.62
832.45	0.54	840.25	69.18
832.60	0.65	840.40	74.91
832.75	0.75	840.55	81.22
832.90	0.83	840.70	87.76
833.05	0.91	840.85	94.63
833.20	0.98	841.00	102.01
833.35	1.05		
833.50	1.11		
833.65	1.17		

Stage-Area-Storage for Pond P4: Mine Ponds

Elevation (feet)	Surface (sq-ft)	Storage (cubic-feet)	Elevation (feet)	Surface (sq-ft)	Storage (cubic-feet)
826.00	3,651	0	833.80	28,629	108,059
826.15	3,906	567	833.95	29,100	112,389
826.30	4,161	1,172	834.10	29,758	116,799
826.45	4,415	1,815	834.25	30,510	121,319
826.60	4,670	2,496	834.40	31,262	125,952
826.75	4,925	3,216	834.55	32,014	130,698
826.90	5,180	3,974	834.70	32,766	135,556
827.05	5,434	4,770	834.85	33,518	140,527
827.20	5,689	5,604	835.00	34,270	145,612
827.35	5,944	6,477	835.15	35,022	150,808
827.50	6,199	7,387	835.30	35,774	156,118
827.65	6,454	8,336	835.45	36,526	161,541
827.80	6,708	9,323	835.60	37,278	167,076
827.95	6,963	10,349	835.75	38,030	172,724
828.10	7,218	11,412	835.90	38,782	178,485
828.25	7,473	12,514	836.05	39,527	184,358
828.40	7,727	13,654	836.20	40,257	190,342
828.55	7,982	14,832	836.35	40,988	196,435
828.70	8,237	16,049	836.50	41,719	202,639
828.85	8,492	17,303	836.65	42,450	208,951
829.00	8,747	18,596	836.80	43,181	215,373
829.15	9,001	19,927	836.95	43,911	221,905
829.30	9,256	21,297	837.10	44,642	228,547
829.45	9,511	22,704	837.25	45,373	235,298
829.60	9,766	24,150	837.40	46,104	242,159
829.75	10,020	25,634	837.55	46,835	249,129
829.90	10,275	27,156	837.70	47,565	256,209
830.05	10,758	28,722	837.85	48,296	263,399
830.20	11,698	30,406	838.00	49,027	270,698
830.35	12,638	32,232	838.15	49,811	278,111
830.50	13,578	34,198	838.30	50,595	285,641
830.65	14,518	36,305	838.45	51,379	293,289
830.80	15,458	38,553	838.60	52,163	301,055
830.95	16,398	40,942	838.75	52,947	308,938
831.10	17,338	43,472	838.90	53,730	316,939
831.25	18,278	46,144	839.05	54,514	325,057
831.40	19,217	48,956	839.20	55,298	333,293
831.55	20,157	51,909	839.35	56,082	341,647
831.70	21,097	55,003	839.50	56,866	350,118
831.85	22,037	58,238	839.65	57,650	358,706
832.00	22,977	61,614	839.80	58,434	367,413
832.15	23,448	65,096	839.95	59,218	376,237
832.30	23,919	68,648	840.10	60,074	385,182
832.45	24,390	72,272	840.25	60,966	394,260
832.60	24,861	75,965	840.40	61,858	403,471
832.75	25,332	79,730	840.55	62,750	412,817
832.90	25,803	83,565	840.70	63,642	422,296
833.05	26,274	87,471	840.85	64,534	431,910
833.20	26,745	91,447	841.00	65,426	441,657
833.35	27,216	95,494			
833.50	27,687	99,612			
833.65	28,158	103,800			



STORMWATER POLLUTION PREVENTION PLAN
It's Greener Now, Inc. – Padua Ridge Gravel Mine Town of Dix, New York

APPENDIX B

ANNUAL COMPREHENSIVE SITE COMPLIANCE EVALUATION AND INSPECTION REPORT



Annual Comprehensive Site Compliance Evaluation and Inspection Report

Comprehensive Site Compliance Evaluation and Inspection Reports must be completed at least once each year after at least three (3) consecutive days of no precipitation to ensure that adequate pollution prevention measures are being implemented and that the measures are protecting the surface water of the State. The assessment area must include all areas where industrial materials or activities are exposed to storm water and areas that have been exposed to spills or leaks within the past 3 years.

1. Are potential pollutant sources identified in the SWPPP accurate?

yes no If no, explain: _____

2. Does the facility drainage map accurately reflect current conditions at the facility?

yes no If no, explain: _____

3. Are industrial materials, residue or trash which could contaminate or be washed away in storm water present on the ground at the facility (good housekeeping)?

yes no If yes, explain: _____

4. Are leaks or spills from industrial equipment, drums, barrels, tanks or similar containers observed to be present onsite?

yes no If yes, explain: _____

5. Are unauthorized non-stormwater discharges or allowable non-storm water discharges that are not certified observed to be present?

yes no If yes, explain: _____



STORMWATER POLLUTION PREVENTION PLAN
It's Greener Now, Inc. – Padua Ridge Gravel Mine Town of Dix, New York

6. Is there any visual evidence of off-site tracking of industrial materials or sediment from where vehicles enter or exit the site?

yes no If yes, explain: _____

7. Is there any visual evidence of tracking, blowing of raw, final or waste materials from exposed areas to areas of no exposure observed?

yes no If yes, explain: _____

8. Is there any visual evidence of or the potential for pollutants to enter the storm water drainage system at this site?

yes no If yes, explain: _____

9. Evaluate the results of the past year's visual and analytical monitoring – are there any problem areas at the site?

yes no If yes, explain: _____

10. Observe all SPDES outfalls / discharge locations - do existing BMP's, structural measures, sediment controls and other storm water management practices appear to be effective / adequate?

yes no If no, explain: _____

11. Does the SWPPP need to be amended?

yes no

If yes, the SWPPP must be amended as soon as practicable and all necessary changes are to be implemented within 12 weeks.



APPENDIX C

MONTHLY STORMWATER MANAGEMENT FEATURE INSPECTION REPORT FORM



STORMWATER POLLUTION PREVENTION PLAN
 It's Greener Now, Inc. – Padua Ridge Gravel Mine Town of Dix, New York

Monthly Storm Water Management Feature Inspection Report Form

Fill out a separate form for each month.

Facility: Padua Ridge Gravel Mine			Permit ID:	
Inspector's Name and Title:				
Date of Inspection:				
Feature/Area	Sediment Depth	Sheen	Integrity	Erosion
Silt Fence				
Hay bales				
Berms				
Ponds				
Drainage ditches				
Material stockpiles				
Aggregate stockpiles				
Aggregate bins				
Conveyors				
Heavy Equipment Storage				
Detail all features and areas that require corrective measures and/or maintenance:				
Status of corrective measures and/or maintenance identified in previous Inspection Report Forms:				
Inspector's Signature:				



STORMWATER POLLUTION PREVENTION PLAN
It's Greener Now, Inc. – Padua Ridge Gravel Mine Town of Dix, New York

APPENDIX D

QUARTERLY VISUAL MONITORING FORM



Department of Environmental Conservation

Quarterly Visual Monitoring Form Multi-Sector GP-0-17-004

All facilities covered under the MSGP must perform Quarterly Visual Monitoring. Please see the permit Part IV.E for additional requirements. This form is part of the facilities records and should be retained onsite with the facility's Stormwater Pollution Prevention Plan. Please do not submit this form to the Department.

SPDES ID Number NYR00 Facility Name

Outfall Number 001 Examiner's Name Examiner's Title

Quarter/Year Rainfall Amount Qualifying Storm? Runoff Source?

Date/Time Collected Date/Time Examined

1. Does the stormwater appear to be colored? Yes No

If yes, describe

2. Is the stormwater clear or transparent? Yes No

If yes, which of the following best describes the clarity of the stormwater: Clear Milky Opaque

3. Can you see a rainbow sheen effect on the water surface? Yes No

If yes, which best describes the sheen? Rainbow Sheen Floating Oil Globules

4. Does the sample have an odor? Yes No

If yes, describe

5. Is there something floating on the surface of the sample? Yes No

If yes, describe

6. Is there something suspended in the water column of the sample? Yes No

If yes, describe

7. Is there something settled on the bottom of the sample?..... Yes No

If yes, describe

8. Is there foam or material forming on the top of the sample surface?..... Yes No

If yes, describe

Detail any concerns, corrective actions taken and any other indicators of pollution present in the sample:

Stormwater Examiner's Signature



APPENDIX E

DISCHARGE MONITORING REPORT FORM



STORMWATER POLLUTION PREVENTION PLAN
It's Greener Now, Inc. – Padua Ridge Gravel Mine Town of Dix, New York

APPENDIX F

ANNUAL CERTIFICATION REPORT

SECTION IV: ANNUAL DRY WEATHER FLOW INSPECTION (Permit Part IV.C)

- 1. Was the annual dry weather flow inspection performed during this reporting period? Yes No
- 2. Were any non-stormwater discharges or indicators of non-stormwater discharges identified? (If no, proceed to Section V) Yes No
- 3. Was the source of the non-stormwater discharge identified? (If no, proceed to question 5) Yes No
- 4. Is the source an allowable non-stormwater discharge (i.e., discharge covered by another SPDES permit or an allowable non-stormwater discharge covered in Part I.B.2 of the MSGP)? Yes No
- 5. Were corrective actions taken to eliminate the unauthorized non-stormwater discharge? (Part IV.C.3) Yes No
- 6. Were corrective actions successful in eliminating the unauthorized non-stormwater discharge? Yes No

SECTION V: STORMWATER MONITORING - BENCHMARK PARAMETERS (Part IV.F.1.a)

- 1. Is benchmark monitoring required at the facility? (If no, proceed to Section VI) Yes No
- 2. Were there any monitoring problems? (Answer "Yes" if storm event criteria was not met or if the laboratory indicated quality assurance/quality control problems). Use Section VIII to explain any monitoring problems. Yes No
- 3. Were any of the sampling results from the reporting year higher than the benchmark cut-off concentrations listed in the permit? (If yes, answer questions 3a and 3b) Yes No

3a. Describe all exceedances and their causes.

3b. Describe the short- and long-term corrective actions taken to address the exceedance(s). Include all changes to existing BMPs and any new BMPs implemented. Specify the SWPPP modifications.

SECTION VI: STORMWATER MONITORING - COMPLIANCE MONITORING (Part IV.F.1.b & Part IV.F.1.d)

1. Is compliance monitoring required at the facility? (If no, proceed to Section VII) Yes No
2. Were there any monitoring problems? (Answer "Yes" if storm event criteria was not met or if the laboratory indicated quality assurance/quality control problems). Use Section VIII to explain any monitoring problems. Yes No
3. Were any of the sampling results from this year higher than the effluent limitations listed in the permit? (If yes, answer questions 3a and 3b.) Yes No

3a. Describe all exceedances and their causes.

3b. Describe the short- and long-term corrective actions taken to address the exceedance(s). Include all changes to existing BMPs and any new BMPs implemented. Specify the SWPPP modifications.

SECTION VII: STORMWATER MONITORING - DISCHARGES TO IMPAIRED WATERBODIES:

1. Is monitoring required for discharges to impaired waterbodies?(Part IV.F.1.c) (If no, proceed to Section VIII) Yes No
2. Were there any monitoring problems? (Answer "Yes" if storm event criteria was not met or if the laboratory indicated quality assurance/quality control problems) Use Section VIII to explain any monitoring problems. Yes No
3. Were any of the quarterly sampling results from the reporting year higher than the benchmark cut-off concentrations or effluent limitations listed in the permit? (If yes, answer questions 3a, 3b and 3c.) Yes No

3a. Describe all exceedances and their causes.

[Empty text box for describing exceedances and causes]

3b. Describe the short- and long-term corrective actions taken to address the exceedance(s). Include all changes to existing BMPs and any new BMPs implemented. Specify the SWPPP modifications.

[Empty text box for describing corrective actions]

3c. Did the follow-up quarterly sample show the corrective and follow up actions to be successful? Yes No

SECTION VIII: SUMMARY:

Describe any facility changes and problems identified during inspections, quarterly visual observations or monitoring. List actions taken to improve the quality of the stormwater discharge from the facility.

[Empty text box for summary section]

CERTIFICATION

I certify under penalty of law that this document and all attachments were prepared under my direction or supervision in accordance with a system designed to assure that qualified personnel properly gathered and evaluated the information submitted. Based on my inquiry of the person or persons who manage the system, or those persons directly responsible for gathering the information, the information submitted is, to the best of my knowledge and belief, true, accurate, and complete. I am aware that there are significant penalties for submitting false information, including the possibility of fine and imprisonment for knowing violations.

[Grid for Owner/Operator First Name (please print or type)]

[Grid for MI]

[Grid for Date]

[Grid for Owner/Operator Last Name (please print or type)]

[Signature line for Owner/Operator Signature]

Owner/Operator Signature



STORMWATER POLLUTION PREVENTION PLAN
It's Greener Now, Inc. – Padua Ridge Gravel Mine Town of Dix, New York

APPENDIX G
SPDES MULTI-SECTOR GENERAL PERMIT
GP-0-17-004



Department of
Environmental
Conservation

NEW YORK STATE DEPARTMENT OF ENVIRONMENTAL CONSERVATION
SPDES MULTI-SECTOR GENERAL PERMIT
FOR STORMWATER DISCHARGES ASSOCIATED WITH INDUSTRIAL ACTIVITY

Permit No. GP-0-17-004

Issued Pursuant to Article 17, Titles 7, 8 and Article 70
of the Environmental Conservation Law

Effective Date: March 01, 2018

Expiration Date: February 28, 2023

Modification Effective Date: July 23, 2020

March 4, 2020 – Modifications consistent with the January 23, 2019 order and March 27, 2019 modified order of the Albany County Supreme Court.

John J. Ferguson
Chief Permit Administrator

3-2-20

Authorized Signature

Date

Address: NYSDEC
Division of Environmental Permits
625 Broadway, 4th Floor
Albany, N.Y. 12233-1750

Preface

The Clean Water Act (CWA)¹ requires that *stormwater discharges associated with industrial activity* from a *point source* to *waters of the United States* are unlawful, unless authorized by a *National Pollutant Discharge Elimination System (NPDES)* permit. New York's *State Pollutant Discharge Elimination System (SPDES)* is a NPDES-approved program with permits issued in accordance with the *Environmental Conservation Law (ECL)*.

Coverage under the Multi-Sector General Permit for *Stormwater Discharges Associated with Industrial Activity (MSGP)* can be obtained by facilities, that conduct industrial activities identified within 40 CFR Part 122.26(b)(14)(i) through (ix) and (xi), with *stormwater discharges to surface waters of the State from a point source*.

To obtain coverage under this permit, an eligible facility must submit a Notice of Intent (NOI) form. Blank NOI forms are available by calling (518) 402-8111 or can be downloaded from the *Department's* website at: <http://www.dec.ny.gov>

Be sure to review and understand the requirements that apply to your facility. This permit includes general requirements applicable to all facilities with permit coverage (Parts I through VI) and industry specific requirements in Part VII which are applicable to 29 different industrial activities.

This MSGP, identified as GP-0-17-004, is effective on March 01, 2018 and will expire on February 28, 2023.

NOTE

All italicized words within this *SPDES General Permit* are defined in Part VIII. Acronyms and Definitions

¹ Also known as the Federal Water Pollution Control Act or Federal Water Pollution Control Act Amendments of 1972 (Pub.L. 92-500, as amended Pub. L. 92-217, Pub. L. 95-576, Pub. L. 96-483 and Pub. L. 97-117, 33 U.S.C. 1251 et.seq.)

Table of Contents

PART I – COVERAGE UNDER THIS PERMIT	1
A. APPLICABILITY	1
B. ELIGIBILITY	1
1. <i>Stormwater Discharges Authorized</i>	1
2. <i>Non-Stormwater Discharges Authorized</i>	2
C. ACTIVITIES WHICH ARE INELIGIBLE FOR COVERAGE UNDER THIS GENERAL PERMIT	2
D. PERMIT AUTHORIZATION	3
1. <i>How to Obtain Authorization</i>	3
2. <i>Submitting the Notice of Intent</i>	4
3. <i>Modifying the Notice of Intent</i>	5
4. <i>Change of Owner or Operator</i>	5
5. <i>Conditional Exclusion for No Exposure</i>	6
E. TERMINATING COVERAGE	6
F. DEADLINES FOR SUBMITTAL OF NOIS AND NOTS AND CHANGES TO THE NOI	7
PART II – EFFLUENT LIMITATIONS	9
A. NON-NUMERIC TECHNOLOGY BASED EFFLUENT LIMITS	9
1. <i>Minimize Exposure</i>	9
2. <i>Good Housekeeping</i>	10
3. <i>Maintenance</i>	10
4. <i>Spill Prevention and Response Procedures</i>	11
5. <i>Erosion and Sediment Controls</i>	12
6. <i>Management of Runoff</i>	12
7. <i>Salt Storage Piles or Piles Containing Salt</i>	12
8. <i>Employee Training</i>	13
9. <i>Non-Stormwater Discharges</i>	14
10. <i>Waste, Garbage and Floatable Debris</i>	14
11. <i>Dust Generation and Vehicle Tracking of Industrial Materials</i>	14
12. <i>Secondary Containment</i>	14
B. NUMERIC EFFLUENT LIMITATIONS.....	15
C. WATER QUALITY BASED EFFLUENT LIMITATIONS	15
1. <i>Maintaining Water Quality Standards</i>	15
2. <i>Impaired Waters</i>	16
D. BEST MANAGEMENT PRACTICES SELECTION AND DESIGN CONSIDERATIONS	16
PART III – STORMWATER POLLUTION PREVENTION PLANS	18
A. CONTENTS OF THE SWPPP	18
1. <i>Pollution Prevention Team</i>	18
2. <i>General Site Description</i>	18
3. <i>Potential Pollutant Sources</i>	19
4. <i>Spills and Releases</i>	20
5. <i>General Location Map</i>	20
6. <i>Site Map</i>	20
7. <i>Stormwater Controls</i>	22
8. <i>Monitoring and Sampling Data</i>	26
9. <i>Copy of Permit Requirements</i>	26
10. <i>Inspection Schedule & Documentation</i>	26
11. <i>Corrective Action Documentation</i>	26
B. SWPPP PREPARER	26

C.	SIGNATURE AND <i>STORMWATER</i> POLLUTION PREVENTION PLAN AVAILABILITY.....	27
D.	SPECIAL SWPPP REQUIREMENTS.....	27
E.	KEEPING SWPPPs CURRENT.....	28
PART IV – INSPECTIONS AND MONITORING.....		30
A.	COMPREHENSIVE SITE COMPLIANCE INSPECTION & EVALUATION.....	30
1.	<i>Scope of the Compliance Inspection & Evaluation</i>	30
2.	<i>Compliance Inspection & Evaluation report</i>	31
B.	ROUTINE INSPECTIONS OF BMPs.....	32
C.	ANNUAL DRY WEATHER FLOW INSPECTION.....	32
D.	COLLECTION AND ANALYSIS OF SAMPLES.....	33
1.	<i>When to Sample</i>	33
2.	<i>Sample Analysis</i>	33
3.	<i>Storm event data</i>	33
4.	<i>Secondary Containment Screening and Sampling</i>	34
E.	QUARTERLY VISUAL MONITORING.....	34
F.	MONITORING REQUIREMENTS.....	35
1.	<i>Types of Pollutant Monitoring</i>	35
2.	<i>Frequency and Timing of Monitoring</i>	37
3.	<i>Monitoring Requirements</i>	38
G.	MONITORING WAIVERS.....	39
PART V - CORRECTIVE ACTIONS.....		42
A.	FOR <i>STORMWATER DISCHARGES</i>	42
B.	FOR <i>NON-STORMWATER DISCHARGES</i>	42
C.	CORRECTIVE ACTION DOCUMENTATION.....	43
PART VI – REPORTING AND RETENTION OF RECORDS.....		44
A.	REPORTING TO THE <i>DEPARTMENT</i>	44
1.	<i>Annual Certification Report (ACR)</i>	44
2.	<i>Discharge Monitoring Report (DMR)</i>	44
3.	<i>Additional reporting</i>	45
4.	<i>Mailing Address</i>	45
B.	MONITORING REPORTING SUBMISSION DEADLINES.....	46
C.	RETENTION OF RECORDS.....	47
1.	<i>Administrative Records</i>	47
2.	<i>Monitoring Activities</i>	47
PART VII – SECTOR SPECIFIC PERMIT REQUIREMENTS.....		48
SECTOR A – <i>TIMBER PRODUCTS</i>		49
SECTOR B – <i>PAPER AND ALLIED PRODUCTS MANUFACTURING</i>		53
SECTOR C – <i>CHEMICAL AND ALLIED PRODUCTS MANUFACTURING</i>		54
SECTOR D – <i>ASPHALT PAVING & ROOFING MATERIALS & LUBRICANT MANUFACTURERS</i>		58
SECTOR E – <i>GLASS, CLAY, CEMENT, CONCRETE AND GYPSUM PRODUCTS</i>		61
SECTOR F – <i>PRIMARY METALS</i>		64
SECTOR G – <i>METAL MINING (ORE MINING & DRESSING)</i>		68
SECTOR H – <i>(RESERVED)</i>		78
SECTOR I – <i>OIL & GAS EXTRACTION AND REFINING</i>		79
SECTOR J – <i>MINERAL MINING & DRESSING</i>		83
SECTOR K – <i>HAZARDOUS WASTE TREATMENT, STORAGE OR DISPOSAL FACILITIES</i>		91
SECTOR L – <i>LANDFILLS, LAND APPLICATION SITES AND NON-COMPLIANT LANDFILLS</i>		96
SECTOR M – <i>AUTOMOBILE SALVAGE YARDS</i>		108
SECTOR N – <i>SCRAP RECYCLING & WASTE RECYCLING FACILITIES</i>		115

SECTOR O – STEAM ELECTRIC GENERATING STATIONS	126
SECTOR P – LAND TRANSPORTATION AND/OR WAREHOUSING	131
SECTOR Q – WATER TRANSPORTATION	135
SECTOR R – SHIP & BOAT BUILDING OR REPAIR YARDS	140
SECTOR S – AIR TRANSPORTATION	144
SECTOR T – TREATMENT WORKS	150
SECTOR U – FOOD & KINDRED PRODUCTS.....	152
SECTOR V – TEXTILE MILLS, APPAREL & OTHER FABRIC PRODUCTS	154
SECTOR W – FURNITURE & FIXTURES	157
SECTOR X – PRINTING & PUBLISHING	158
SECTOR Y – RUBBER, PLASTICS & MISCELLANEOUS MANUFACTURING INDUSTRIES.....	161
SECTOR Z – LEATHER TANNING AND FINISHING	164
SECTOR AA - FABRICATED METAL PRODUCTS.....	167
SECTOR AB – TRANSPORTATION EQUIPMENT, INDUSTRIAL & COMMERCIAL MACHINERY	173
SECTOR AC – ELECTRONIC, ELECTRICAL EQUIPMENT & COMPONENTS, PHOTOGRAPHIC & OPTICAL GOODS	174
APPENDIX A – DEFINITIONS AND ACRONYMS.....	175
ACRONYMS.....	175
DEFINITIONS	176
APPENDIX B - SECTORS OF INDUSTRIAL ACTIVITY COVERED BY THIS PERMIT	185
APPENDIX C - SECTORS SUBJECT TO BENCHMARK MONITORING REQUIREMENTS.....	190
APPENDIX D - COMPLIANCE MONITORING REQUIREMENTS - INDUSTRIAL ACTIVITIES SUBJECT TO EFFLUENT LIMITATION GUIDELINES	192
APPENDIX E - ADDITIONAL INFORMATION FOR NEW <i>DISCHARGES</i>	193
APPENDIX F - LIST OF DEC REGIONAL OFFICES	195
APPENDIX G – POLLUTANT(S) OF CONCERN FOR IMPAIRED WATERBODIES REFERENCE TABLE.....	196
APPENDIX H – STANDARD PERMIT CONDITIONS.....	198
1. DUTY TO COMPLY.....	198
2. CONTINUATION OF THE EXPIRED GENERAL PERMIT	198
3. ENFORCEMENT.....	198
4. NEED TO HALT OR REDUCE ACTIVITY NOT A DEFENSE.....	198
5. DUTY TO MITIGATE.....	198
6. DUTY TO PROVIDE INFORMATION	198
7. OTHER INFORMATION	199
8. SIGNATORY REQUIREMENTS	199
9. PENALTIES FOR FALSIFICATION OF DOCUMENTATION/PENALTIES RELATED TO MONITORING DEVICES	200
10. OIL AND HAZARDOUS SUBSTANCE LIABILITY.....	200
11. PROPERTY RIGHTS	200
12. SEVERABILITY.....	201
13. REQUIRING AN INDIVIDUAL PERMIT OR AN ALTERNATIVE GENERAL PERMIT	201
14. STATE/ENVIRONMENTAL LAWS	201
15. PROPER OPERATION AND MAINTENANCE	202
16. INSPECTION AND ENTRY.....	202
17. DEFINITIONS.....	202
18. REOPENER CLAUSE.....	202

Part I – Coverage under this Permit

A. Applicability

1. Coverage under this permit can be obtained in all areas of New York State where the *Department* implements CWA §402, where facilities:
 - a. Conduct industrial activities identified within 40 CFR Part 122.26(b)(14)(i) through (ix) and (xi);
 - b. Have a primary *industrial activity* that has a Standard Industrial Classification (SIC) code listed in Appendix B; and
 - c. Have *stormwater discharges to surface waters of the State* from a *point source*.
2. An industrial facility that meets the criteria in Part I.A.1 that is owned and operated by a *municipality* covered by a *Municipal Separate Storm Sewer System (MS4)* Permit does not need coverage under this MSGP permit provided that the *MS4*:
 - a. Includes the facility in the *MS4's Stormwater* Management Program Plan;
 - b. Implements the plan in accordance with the *MS4* Permit; and
 - c. Completes all the applicable monitoring, corrective actions and reporting requirements specified in the MSGP. The deadlines for reporting are specified in the *MS4* permit.

B. Eligibility

Any *stormwater discharges* that are ineligible for coverage under Part I.C of this permit are not authorized by this permit and the *owner or operator* must either apply for a separate SPDES permit to cover those ineligible *discharges* or take steps necessary to make the *discharges* eligible for coverage under this permit.

1. *Stormwater Discharges Authorized*

Subject to compliance with the terms and conditions of this permit, the following *stormwater discharges* are authorized by this permit.

- a. *Stormwater discharges* associated with industrial activities whose primary *industrial activity* has a Standard Industrial Classification (SIC) code listed in Appendix B.
- b. *Discharges* subject to numeric effluent limitations listed in Part IV.F.3.e or Appendix D.

- c. *Discharges* to impaired waterbodies that meet the requirements of Part II.C.2.
- d. This permit also provides permit coverage to facilities in Sectors J and L for construction activities pursuant to 40 CFR 122.26(b)(14)(x).
- e. *Stormwater discharges associated with industrial activity* that are mixed with stormwater *discharges* authorized under a different *SPDES* general permit or an *individual SPDES permit* provided that all *discharges* are in compliance with the terms and conditions of the various permits;
- f. *Stormwater discharges associated with industrial activity* which are authorized by this permit may be combined with other sources of stormwater which are not classified as associated with *industrial activity* pursuant to 40 CFR 122.26(b)(14), provided that the combined *discharge* is in compliance with this permit and has not been designated by the Department as requiring an individual *SPDES* Permit.
- g. *Stormwater discharges associated with industrial activity* listed in Part I.C.2 are eligible for coverage if the Department makes a determination that coverage under this general permit will not result in backsliding as specified in 6 NYCRR 750-1.10.

2. **Non-Stormwater Discharges Authorized**

Subject to compliance with the terms and conditions of this permit, only the following non-*stormwater discharges are authorized* by this permit provided that the SWPPP contains the documentation specified in Part III.A.7.f.

- a. Non-*stormwater discharges* listed in Part 750-1.2(a)(29)(vi), with the following exception:
 - o *Discharges* from firefighting activities are authorized only when the firefighting activities are emergencies/unplanned.
- b. Incidental windblown mist from cooling towers that collect on rooftops or adjacent portions of the facility, but not intentional *discharges* from cooling tower (e.g.; "piped" cooling tower blowdown or drains).

C. **Activities which are Ineligible for Coverage under this General Permit**

The following are **not** authorized by this permit:

1. *Discharges* from *industrial activity* that are mixed with sources of non-*stormwater* other than those expressly authorized under this permit.
2. Unless otherwise determined by the Department to be eligible under Part I.B.g, *stormwater discharges from industrial activity* where:

- a. an *individual SPDES permit* authorizing such *discharges* has been revoked, suspended or denied;
 - b. the facility has failed to renew an expired *individual SPDES permit* which authorized such *discharges*; or
 - c. the *discharge* is covered by another SPDES permit.
3. *Discharges from industrial activity* which are subject to an *effluent limitation guideline* addressing *stormwater* which is not specifically listed in Table IV-3 or Appendix D (or a combination of *stormwater* and process water);
 4. *Discharges from industrial activity from construction activities*, except *stormwater discharges* from portions of a construction site at facilities covered under Sectors J & L or that can be classified as an *industrial activity* under 40 CFR 122.26(b)(14)(i) through (ix) or (xi).
 5. *Discharges from industrial activities* that may adversely affect an endangered or threatened species, or its critical habitat, unless the *owner or operator* has obtained a permit issued pursuant to Title 6 of the Official Compilation of Codes, Rules and Regulations of the State of New York (NYCRR) Part 182 for the facility or the *Department* has issued a letter of non-jurisdiction for the facility.
 6. *Discharges* occurring on federal lands from *industrial activity* from either: inactive mining, inactive landfills, or inactive oil and gas operations where an *owner or operator* cannot be identified.
 7. *Discharges from industrial activity* to impaired waterbodies at facilities that fail to maintain eligibility in accordance with Part II.C.2.
 8. *Discharges* of hazardous substances (as listed in 6 NYCRR Part 597) or petroleum.
 9. *Discharges of industrial waste and other wastes to Surface Waters of the State* that are classified as AA-Special fresh surface waters as defined in 6 NYCRR Part 800 to 941.

D. Permit Authorization

1. How to Obtain Authorization

- a. To obtain authorization under this permit, the *owner or operator* of an eligible facility must:

(1) Develop and implement a *Stormwater Pollution Prevention Plan* (SWPPP) or update the existing SWPPP, in accordance with the

requirements in Part III and applicable sections of Part VII prior to submitting the NOI; and

- (2) Submit a complete Notice of Intent in accordance with Part I.D.2 and signed in accordance with Appendix H.8. The NOI certifies that the facility is eligible for coverage according to Part I.B, and provides information on the facility's industrial activities and related *discharges*.
 - If more than one activity listed in Appendix B is being performed at a facility, all SIC codes must be included in the NOI submitted to the *Department* to gain or renew coverage under MSGP.
- b. New *stormwater discharges associated with industrial activity* which require any other *Uniform Procedures Act* permits (*Environmental Conservation Law*, 6 NYCRR Part 621) cannot be covered under this permit until the other required permits are obtained (see Appendix E). In addition to the requirements in Part I.D.1.a, new dischargers must:
 - (1) Satisfy any project review pursuant to the State Environmental Quality Review Act ("SEQRA"), when SEQRA is applicable (see Appendix E). See the Department's website (<http://www.dec.ny.gov/>) for more information; and
 - (2) Obtain all necessary Department permits subject to the Uniform Procedures Act ("UPA") (see 6 NYCRR Part 621), unless otherwise notified by the Department pursuant to 6 NYCRR 621.3(a)(4) (see Appendix E).
 - (3) Submit a report including the information specified in Appendix E with the NOI. A copy of this report must be retained with the SWPPP.

2. Submitting the Notice of Intent

- a. An *owner or operator* of a facility meeting the eligibility requirements in Part I.B must submit a complete NOI, which is signed in accordance with Appendix H.8, to the *Department*.
 - (1) Prior to December 20, 2020, the *owner or operator* may elect to submit the Notice of Intent by mailing a paper form to the address below or by using the *Department's* online NOI.
 - (2) Beginning December 21, 2020 and in accordance with the EPA's *NPDES* Electronic Reporting Rule, the *owner or operator* must submit the NOI electronically using the *Department's* online NOI. Both versions of the NOI are located on the *Department's* website <http://www.dec.ny.gov/>.

- b. An *owner or operator* who submits a complete NOI will be authorized to *discharge stormwater* under the terms and conditions of this permit, unless otherwise notified by the Department, Thirty (30) calendar days after the date the *Department* receives a complete NOI (electronic or paper).
- c. The paper NOI is to be submitted to the following address:

MSGP Permit Coordinator
NYSDEC, Division of Water
Bureau of Water Permits
625 Broadway
Albany, NY 12233-3505

3. *Modifying the Notice of Intent*

After gaining authorization under this permit, an *owner or operator* must notify the Department of any corrections or updates to the information provided in the original NOI. All modifications must be reported. Stormwater Discharges associated with industrial activity or outfalls not included in the most recent NOI that is on file at the Department are not authorized unless and until the corrections or updates have been received by the Department.

In order to modify the original NOI, an *owner or operator* must submit corrections or updated information, by submitting:

- a. Changes electronically using the Departments electronic NOI; or
- b. A completed paper NOI.

Modifications to the original NOI become effective on the date the *Department* receives the electronic NOI or a complete paper NOI.

4. *Change of Owner or Operator*

When the *owner or operator* of a facility changes, the original *owner or operator* should notify the new *owner or operator* in writing of the possible requirement to have coverage under this permit.

- a. The original *owner or operator* must submit the Notice of Termination to end coverage under this permit for their facility in accordance with Part I.E; and,
- b. The new *owner or operator* shall refer to Part I of this permit to determine if they need coverage under this permit.
- c. The original *owner or operator* will continue to be responsible for compliance with all permit conditions and fees until the NOT has been received.

5. Conditional Exclusion for No Exposure

- a. Facilities may qualify for a "Conditional Exclusion for No Exposure" when all industrial activities and materials are completely sheltered from exposure to rain, snow, snowmelt and/or runoff. Facilities qualifying for this exclusion are not required to obtain coverage under this permit.
 - (1) Facilities with uncovered parking areas for vehicles awaiting maintenance may be eligible for this waiver if only routine maintenance is performed inside and all other *No Exposure* criteria are met.
- b. Facilities accepting or repairing disabled vehicles and/or vehicles that have been involved in accidents are not eligible for the Conditional Exclusion for *No Exposure*.
- c. To obtain the "Conditional Exclusion of No Exposure", the *owner or operator* must submit a complete No Exposure Certification to the *Department* using forms provided by the *Department*. This certification must be submitted once every 5 years and is non-transferable.
 - (1) Facilities discharging industrial waste and other wastes to AA-Special waters, must submit their No Exposure Certification to the Department by June 23, 2020
- d. Facilities must maintain the condition of *no exposure*. The *no exposure* exclusion ceases to apply when industrial activities or materials become exposed. The *Department* reserves the right to require permit coverage when *stormwater discharges* from the facility are likely to have an adverse impact on water quality.

E. Terminating Coverage

To terminate permit coverage, the *owner or operator* must submit a complete Notice of Termination (NOT) which is signed in accordance with Appendix H.8. The *owner or operator* continues to be responsible for meeting permit requirements and payment of annual fees until a complete NOT is received by the *Department*. The *owner or operator* must submit an NOT to terminate coverage under this permit when one or more of the following conditions are met:

1. When all *stormwater discharges* associated with *industrial activity* authorized by this permit are eliminated;
2. If all *stormwater discharges* are conveyed to a sanitary sewer, treatment works or a combined sewer system and the *owner or operator* of such system has accepted responsibility or approved connection for the *discharge*;
3. All industrial activities covered under this *SPDES* permit cease AND all materials, equipment or other potential *pollutants*, including but not limited to, residue in soils are removed;

4. When a different *SPDES* authorization for all *discharges* covered under this permit becomes effective; or
5. When the *owner or operator* of the *stormwater discharges* associated with *industrial activity* at a facility changes. (See Part I.D.4)
6. Facilities that meet the requirements for No Exposure as specified in Part I.D.5 are not required to submit a Notice of Termination form to terminate MSGP coverage.
 - a. MSGP coverage will terminate automatically upon submission of a complete No Exposure Certification form to the Department for facilities that do not discharge to AA-Special waters.
7. MSGP coverage will terminate automatically on July 23, 2020 for facilities that discharge industrial waste and other wastes to AA-Special waters.

F. Deadlines for submittal of NOIs and NOTs and Changes to the NOI

1. New *dischargers* or other owners or operators of facilities who intend to obtain coverage under this general permit shall submit a complete NOI according to the following schedule:
 - a. For electronic NOIs - at least thirty (30) calendar days before *industrial activity* begins at the facility; or
 - b. For paper NOIs - at least thirty (30) calendar days before *industrial activity* begins at the facility.
2. Facilities with effective coverage on September 30, 2017, under the *SPDES* General Permit for *Stormwater Discharges Associated with Industrial Activity* (GP-0-12-001), are eligible for continued coverage under this permit (GP-0-17-004) on an interim basis for up to one-hundred twenty (120) calendar days from the effective date of the permit. During this interim period, an *owner or operator* must:
 - a. Update the facility's SWPPP to comply with the requirements of this permit prior to submitting the NOI; and,
 - b. Submit a complete NOI, signed in accordance with Appendix H.8. The complete NOI must be received within ninety (90) calendar days from the date this permit becomes effective.
3. When the *owner or operator* of a facility which is covered by this permit changes, the previous *owner or operator* must submit an NOT in accordance with Part I.E. The new *owner or operator* shall refer to Part I of this permit to determine if they need coverage under this permit.

4. An Owner or Operator must promptly notify the *Department* of any changes or corrections to the submitted NOI by submitting changes according to the following procedures:
 - a. For electronic NOIs - If there is an electronic NOI on file with the Department, submit the changes/updates to the NOI electronically;
 - b. For Paper NOIs - submit a new fully completed NOI. An incomplete NOI will not be accepted by the Department.

Stormwater discharges from industrial activities or outfalls not included in previously submitted NOIs are not authorized until a complete NOI is received.

Part II – Effluent Limitations

Effluent limits are required to *minimize* the *discharge* of *pollutants*. The term “*minimize*” means reduce and/or eliminate to the extent achievable using *control measures* (including *Best Management Practices* (BMPs) selected and designed in accordance with Part II.D) that are technologically available and economically practicable and achievable in light of best industry practice. *Control measures* are selected to meet the limits (non-numeric, numeric and water quality based) contained in this Part.

A. Non-Numeric Technology Based Effluent Limits

The Owner or Operator must comply with the following non-numeric effluent limits as well as any sector-specific non-numeric effluent limits in Part VII.

1. Minimize Exposure

The *owner or operator* must *minimize* the exposure of manufacturing, processing, and material storage areas to rain, snow, snowmelt, and runoff in order to *minimize pollutant discharges* by either locating these industrial materials and activities inside or protecting them with storm resistant coverings. This includes areas used for loading and unloading, storage, disposal, cleaning, maintenance, and fueling operations. Unless not technologically possible or not economically practicable and achievable in light of best industry practices, the *owner or operator* must also:

- a. Use grading, berming, or curbing to prevent runoff of contaminated flows and divert run-on away from these areas;
- b. Locate materials, equipment, and activities so that leaks and spills are contained in existing containment and diversion systems (confine the storage of leaky or leak-prone vehicles and equipment awaiting maintenance to protected areas);
- c. Clean up spills and leaks promptly using dry methods (e.g., absorbents) to prevent the *discharge of pollutants*;
- d. Store leaky vehicles and equipment indoors or, if stored outdoors, use drip pans and absorbents;
- e. Use spill/overflow protection equipment;
- f. Perform all vehicle and/or equipment cleaning operations indoors, under cover, or in bermed areas that prevent runoff and run-on and also that capture any overspray; and ensure that all washwater drains to a proper collection system (i.e., not the *stormwater* drainage system);

- g. Drain fluids from equipment and vehicles that will be decommissioned, and, for any equipment and vehicles that will remain unused for extended periods of time, inspect at least monthly for leaks; and
- h. *Minimize* exposure of chemicals by replacing with a less toxic alternative.

Note: The *discharge* of vehicle and equipment washwater, including tank cleaning operations, is not authorized by this permit. These wastewaters must be covered under a separate *SPDES* permit, *discharged* to a sanitary sewer in accordance with applicable industrial pretreatment requirements, or disposed of otherwise in accordance with applicable law.

2. *Good Housekeeping*

The *owner or operator* must keep clean all exposed areas that are potential sources of *pollutants*. The *owner or operator* must perform good housekeeping measures in order to *minimize pollutant discharges*, including but not limited to, the following:

- a. Sweep or vacuum at regular intervals or, alternatively, wash down the area and collect and/or treat, and properly dispose of the washdown water;
- b. Store materials in appropriate containers;
- c. Keep all dumpster lids closed when not in use. For dumpsters and roll off boxes that do not have lids and could leak, ensure that *discharges* have a control (e.g., secondary containment, treatment); and,
- d. Prevent the discharge of waste, garbage and floatable debris by keeping exposed areas free of such materials, or by intercepting them before they are *discharged*;
 - o Plastic Materials Requirements: Facilities that handle pre-production plastic must implement *Best Management Practices* to eliminate *discharges* of plastic in *stormwater*. Examples of plastic material required to be addressed as *stormwater pollutants* include plastic resin pellets, powders, flakes, additives, regrind, scrap, waste and recycling.

3. *Maintenance*

- a. In order to *minimize pollutant discharges* and achieve the effluent limits in this permit, the *owner or operator* must maintain all industrial equipment and systems and *control measures* in effective operating condition. This includes:
 - (1) Performing inspections and preventive maintenance of *stormwater* drainage, source controls, treatment systems, and plant equipment and systems that could fail and result in contamination of *stormwater*;

- (2) Maintaining non-structural *control measures* (e.g., keep spill response supplies available, personnel appropriately trained);
 - (3) Inspecting and maintaining baghouses quarterly during periods of operation, or in accordance with manufacturers recommendations, to prevent the escape of dust from the system and immediately removing any accumulated dust at the base of the exterior baghouse; and,
 - (4) Cleaning catch basins when the depth of debris reaches two-thirds of the sump depth and keeping the debris surface at least six inches below the lowest outlet pipe.
- b. Routine maintenance shall be performed to ensure BMPs are operating properly. When a BMP is not functioning to its designed effectiveness and is in need of repair or replacement:
- (1) Maintenance shall be performed before the next anticipated storm event, or as necessary to maintain the continued effectiveness of stormwater controls. If maintenance prior to the next anticipated storm event is impracticable, maintenance must be scheduled and accomplished as soon as practicable, but not more than 12 weeks after completion of the most recent routine facility inspection or the comprehensive site inspection, unless permission for a later date is granted in writing by the Department; and,
 - (2) All reasonable steps shall be taken to prevent or minimize the discharge of pollutants until the final repair or replacement is implemented, including cleaning up any contaminated surfaces so that the material will not be discharged during subsequent storm events.

4. Spill Prevention and Response Procedures

- a. The *owner or operator* must *minimize* the potential for leaks, spills and other releases that may be exposed to *stormwater* and develop plans for effective response to such spills if or when they occur in order to *minimize pollutant discharges*. At a minimum, the *owner or operator* must:
- (1) Plainly label containers (e.g., “Used Oil,” “Spent Solvents,” “Fertilizers and Pesticides”) that could be susceptible to spillage or leakage to encourage proper handling and facilitate rapid response if spills or leaks occur;
 - (2) Implement procedures for material storage and handling, including the use of secondary containment and barriers between material storage and traffic areas, or a similarly effective means designed to prevent the *discharge of pollutants* from these areas;

- (3) Where practicable, protect industrial materials and activities with a storm resistant shelter to prevent exposure to rain, snow, snowmelt, or runoff;
 - (4) Develop training on the procedures for stopping, containing, and cleaning up leaks, spills, and other releases. As appropriate, execute such procedures as soon as possible;
 - (5) Keep spill kits on-site, located near areas where spills may occur or where a rapid response can be made; and
 - (6) Develop procedures for notification of the appropriate facility personnel, emergency response agencies, and regulatory agencies when a leak, spill, or other release occurs. If possible, one of these individuals should be a member of the *stormwater* pollution prevention team (see Part III.A.1). Any spills must be reported in accordance with Part VI.A.3.
- b. Measures for cleaning up spills or leaks must be consistent with applicable petroleum bulk storage, chemical bulk storage or hazardous waste management regulations at 6 NYCRR Parts 596-599, 613 and 370-373.
 - c. This permit does not relieve the *owner or operator* of any reporting or other requirements related to spills or other releases of petroleum or hazardous substances. Any spill of a hazardous substance must be reported in accordance with 6 NYCRR 597.4. Any spill of petroleum must be reported in accordance with 6 NYCRR 613.6 or 17 NYCRR 32.3.

5. Erosion and Sediment Controls

The *owner or operator* must stabilize exposed areas and control runoff using structural and/or non-structural *control measures* to *minimize* onsite erosion and sedimentation. Erosion and Sediment Controls must be in accordance with the New York State Standards & Specification for Erosion & Sediment Control (2016). Where erosion and sediment control practices are not designed in conformance with the design criteria included in the technical standard, the *owner or operator* must demonstrate equivalence to the technical standard.

6. Management of Runoff

The *owner or operator* must divert, infiltrate, reuse, contain, or otherwise reduce *stormwater* runoff, to *minimize pollutants* in the *discharges*.

7. Salt Storage Piles or Piles Containing Salt

In order to *minimize pollutant discharges* the *owner or operator* must enclose or cover storage piles of salt, or piles containing salt, used for deicing, maintenance of paved surfaces, or for other commercial or industrial purposes. The *owner or operator* must implement appropriate measures

(e.g., good housekeeping, diversions, containment) to *minimize* exposure resulting from adding to or removing materials from the pile.

8. *Employee Training*

- a. The *owner or operator* must train all employees who work in areas where industrial materials or activities are exposed to *stormwater*, or who are responsible for implementing activities necessary to meet the conditions of this permit (e.g., inspectors, maintenance personnel), including all members of the *Stormwater Pollution Prevention Team*.
- b. At a minimum, all training must be conducted annually.
- c. The *owner or operator* must ensure the following personnel understand the requirements of this permit and their specific responsibilities with respect to those requirements:
 - (1) Personnel who are responsible for the design, installation, maintenance, and/or repair of *control measures*;
 - (2) Personnel responsible for the storage and handling of chemicals and materials that could become contaminants found in *stormwater discharges*;
 - (3) Personnel who are responsible for conducting and documenting monitoring and inspections as required in Part IV; and,
 - (4) Personnel who are responsible for taking and documenting corrective actions as required in Part V.
- d. Personnel identified in Part II.A.8.c must be trained in the following subjects if the subject is appropriate to the scope of their SWPPP responsibilities.
 - (1) An overview of what is in the SWPPP and the purpose of the SWPPP;
 - (2) Spill response procedures, good housekeeping, maintenance requirements and material management practices;
 - (3) How to recognize unauthorized *discharges*;
 - (4) The location of all controls on the site required by this permit, and how to evaluate their condition and maintenance needs;
 - (5) The proper procedures to follow with respect to permit's pollution prevention requirements, including sampling and reporting; and

(6) When and how to conduct inspections, record applicable findings, and take corrective actions.

9. Non-Stormwater Discharges

The *owner or operator* must eliminate non-stormwater discharges not authorized by a *SPDES* permit in accordance with Part I.B.2.

10. Waste, Garbage and Floatable Debris

The *owner or operator* must ensure that waste, garbage, and floatable debris are not discharged to *surface waters of the state* by keeping exposed areas free of such materials or by intercepting them before they are discharged.

11. Dust Generation and Vehicle Tracking of Industrial Materials

The *owner or operator* must minimize generation of dust and off-site tracking of raw, final, or waste materials in order to minimize the pollutant discharges.

12. Secondary Containment

The *owner or operator* must ensure that compliance is maintained with all applicable regulations including, but not limited to, those involving releases, registration, handling and storage of petroleum, chemical bulk and hazardous waste storage facilities (6 NYCRR 596-599, 613 and 370-373).

Where it is not feasible to eliminate discharges from handling and storage areas, the *owner or operator* must implement the following BMPs:

a. Loading and unloading areas shall be operated to minimize spills, leaks or the discharge of pollutants in stormwater. Protection such as roofs, overhangs or door skirts to enclose trailer ends at truck loading/unloading docks shall be provided as appropriate.

(1) During deliveries, have staff familiar with spill prevention and response procedures present to ensure that any leaks/spills are immediately contained and cleaned up; and

b. Use of spill and overflow protection (e.g., drip pans, and/or other containment devices placed beneath fuel oil connectors to contain potential spillage during deliveries or from leaks at the connectors).

c. All spilled or leaked substances must be removed from secondary containment systems as soon as practical and for Chemical Bulk Storage (CBS) storage areas within 24 hours of the *owner or operator* discovering the spill, unless authorization is received from the *Department*.

(1) The containment system must be thoroughly cleaned to remove any residual contamination which could cause contamination of stormwater and the resulting discharge of pollutants to waters of the State.

- (2) Following spill cleanup the affected area must be completely flushed with clean water three times and the water removed after each flushing for proper disposal in an on-site or off-site wastewater treatment plant designed to treat and permitted to *discharge* such wastewater.
- (3) The *owner or operator* shall test the first batch of *stormwater* following the spill cleanup to determine *discharge* acceptability. If the water contains no *pollutants* it may be *discharged*, otherwise it must be disposed of as noted above. (See Part IV.F.1.e for the list of parameters to be sampled.)
- d. *Stormwater* must be removed from a secondary containment system before it compromises the system's capacity. Each *discharge* may only proceed with the prior approval of the facility representative responsible for ensuring *SPDES* permit compliance. Bulk storage secondary containment drainage systems must be locked in a closed position except when the *owner or operator* is in the process of draining accumulated *stormwater*. Transfer area secondary containment drainage systems must be locked in a closed position during all transfers and must not be reopened unless the transfer area is clean of contaminants. *Stormwater discharges* from secondary containment systems should be avoided during periods of precipitation. A logbook shall be maintained on site noting, for each *discharge*:
- Screening method;
 - Results of screening;
 - Date time and volume; and,
 - Supervising personnel.
- e. Prohibited *Discharges* - In all cases, any *discharge* which contains a visible sheen, foam, or odor, or may cause or contribute to a violation of water quality is prohibited.

B. Numeric Effluent Limitations

The *owner or operator* of facilities listed in an industrial category subject to one or more of the *effluent limitations guidelines* identified in Appendix D, must meet the numeric effluent limits specified in the referenced Sector in Part VII.

C. Water Quality Based Effluent Limitations

1. Maintaining Water Quality Standards

- a. The *Department* expects that compliance with the other conditions of this permit will control *discharges* necessary to meet applicable water quality standards. It shall be a violation of the *Environmental Conservation Law (ECL)* for any *discharge* authorized by this general permit to either cause or contribute to a violation of water quality standards as contained in 6 NYCRR Parts 700-705.

- b. If there is evidence indicating that the *stormwater discharges* authorized by this permit are causing, have the reasonable potential to cause, or are contributing to a violation of the *water quality standards*; the *owner or operator* must take appropriate corrective action in accordance with Part V of this permit. To address the *water quality standard* violation the *owner or operator* may need to provide additional information, include and implement appropriate controls in the SWPPP to correct the problem, or obtain an *individual SPDES permit*. Failure to complete the required corrective action is a violation of this permit.
- c. In all cases, any *discharge* which contains a visible sheen, foam, or odor, or may cause or contribute to a violation of water quality is prohibited.

2. Impaired Waters

- a. *Discharges* to an *impaired waterbody* are not eligible for coverage under this permit if the cause of impairment is a *pollutant* of concern included in the *benchmarks* and/or numeric *effluent limitations* to which the facility is subject unless the facility:
 - (1) Prevents all exposure to *stormwater* of the *pollutant(s)* for which the waterbody is impaired; or
 - (2) Documents that the *pollutant* for which the waterbody is impaired is not present on-site; or
 - (3) Provides additional information in the SWPPP to *minimize* the *pollutant* of concern causing the impairment as specified in Part III.D.2.
- b. If conditions at the facility conform with Part II.C.2.a(1) or (2) all analysis and documentation that supports eligibility must be maintained with the SWPPP.

D. Best Management Practices Selection and Design Considerations

The *owner or operator* must consider the following when selecting and designing *BMPs*:

- a. How to prevent *stormwater* from interacting with and contacting *pollutants* and *pollutant* sources;
- b. The use of *BMPs* in series or combination;
- c. Assessment of the type of *pollutant*, the quantity and nature of the *pollutant(s)*, and their potential to impact the water quality of receiving waters;

- d. Opportunities to combine the dual purposes of water quality protection and local flood control benefits, including physical impacts of high flows on streams (e.g., bank erosion, impairment of aquatic habitat, etc.);
- e. Opportunities to offset the impact of *impervious areas* of the facility on groundwater recharge and base flows in local streams, taking into account the potential for groundwater contamination (i.e., *hotspots*);
- f. Opportunities to attenuate flow using open vegetated swales and natural depressions;
- g. Conservation and/or restoration of the riparian buffers of streams and rivers; and,
- h. The use of treatment interceptors (e.g., swirl separators and sand filters).

Part III – Stormwater Pollution Prevention Plans

The SWPPP documents the practices and procedures to ensure compliance with the conditions of this permit, including the selection, design, installation and maintenance of *control measures* selected to meet *effluent limitations* in Parts II and VII.

The *owner or operator* is responsible for the implementation of the SWPPP.

Note: The SWPPP requirements of this general permit may be fulfilled by incorporating by reference other plans or documents such as an Erosion and Sediment Control (ESC) plan, a Mined Land Use Plan, a Spill Prevention Control and Countermeasure (SPCC) plan developed for the facility or *BMP* programs otherwise required for the facility provided that the incorporated plan(s) meet or exceed the SWPPP content requirements of Part III.A and the applicable activity-specific requirements in Part VII. All plans incorporated by reference into the SWPPP become enforceable under this permit; however, this enforcement is limited only to those aspects of these other plans that are specifically referenced to provide information or practices required for the SWPPP.

A. Contents of the SWPPP

All SWPPPs shall include, at a minimum:

1. Pollution Prevention Team

Identify the individuals (by name or title) and their role, in assisting the *owner or operator* in developing, implementing, maintaining and revising the facility's SWPPP.

2. General Site Description

A written description of:

- a. Industrial activities occurring in each drainage area.
- b. The name of the nearest receiving water(s), including intermittent streams and wetlands (mapped and federally regulated wetlands) that may receive *discharges* from the facility.
- c. If *stormwater* is *discharged* to an *MS4*, the SWPPP must identify the *MS4* operator and the receiving water to which the *MS4 discharges*.
- d. The flow path of *stormwater* within the facility, and the general path of *stormwater* flows between the facility and the nearest surface waterbody(ies) and/or location(s) where *stormwater* enters an *MS4*, if applicable.

- e. The run-on from adjacent properties, if present. The *owner or operator* may include an evaluation of how the quantity or quality of the *stormwater* running onto the facility impacts the facility's *stormwater discharges*.
- f. Any *discharges* that are currently covered by another *SPDES* permit at the facility (e.g., process wastewater, sanitary wastewater, non-contact cooling water, etc.)
- g. Size of the property in acres.
- h. Provide an estimate of the percent imperviousness of the site using the following formula:

$$\frac{(\text{Area of Roofs} + \text{Area of Paved and Other Impervious Surfaces}) \times 100}{\text{Total Area of Facility}}$$
- i. Locations of sensitive areas (e.g. *impaired waters*; listed threatened & endangered species or their critical habitat; etc.)

3. **Potential Pollutant Sources**

The SWPPP shall identify each area at the facility where industrial materials or activities are exposed to *stormwater* or from which authorized non-*stormwater discharges* originate, including any potential *pollutant* sources for which the facility has reporting requirements under the Emergency Planning and Community Right-To-Know Act (EPCRA), Section 313.

- a. Industrial materials or activities include: industrial machinery; raw materials; intermediate products; byproducts; final products or waste products; and, material handling activities which includes storage, loading and unloading, transportation or conveyance of any raw material, intermediate product, final product or waste product.
- b. For each separate area identified, the description must include:
 - (1) **Activities** - A list of the activities occurring in the area (e.g., material storage, equipment fueling and cleaning, cutting steel beams, etc.); and
 - (2) **Pollutants** - A list of the associated *pollutant(s)* or *pollutant* parameter(s) (e.g., crankcase oil, iron, biochemical oxygen demand, pH, etc.) for each activity. The *pollutant* list must include all *significant materials* that have been handled, treated, stored or disposed in a manner to allow exposure to *stormwater* for a period of three years before being covered under this permit.
 - (3) **Potential for presence in stormwater** - For each area of the facility that generates *stormwater discharges associated with industrial activity* a prediction of the direction of flow, and the likelihood of the *industrial*

activity to contaminate the *stormwater discharge*. Factors to consider include the toxicity of chemicals; quantity of chemicals used, produced or *discharged*; the likelihood of contact with *stormwater*; and history of *reportable* leaks or spills of toxic or hazardous *pollutants*.

4. *Spills and Releases*

- a. The SWPPP must clearly identify areas where potential spills or releases can contribute to *pollutants* in *stormwater discharges* and their accompanying drainage points.
- b. For areas that are exposed to precipitation or that otherwise drain to a *stormwater* conveyance to be covered under this permit, the SWPPP must include a list of *reportable* spills or releases² of petroleum and hazardous substances or other *pollutants*, including unauthorized *non-stormwater discharges*, that may adversely affect water quality that occurred during the three-year period prior to the date of the submission of a NOI. The list must be updated when *reportable* spills or releases occur.
- c. Following any spill or release, the *owner or operator* must evaluate the adequacy of the BMPs identified in the facility's SWPPP. If the BMPs are inadequate, the SWPPP must be updated to identify new BMPs that will prevent reoccurrence and improve the emergency response to such releases.
- d. Document when training occurs on the procedures for stopping, containing, and cleaning up leaks, spills, and other releases.
- e. Define and document the appropriate facility personnel, emergency response agencies, and regulatory agencies to be notified when a leak, spill, or other release occurs.

5. *General Location Map*

A general location map (e.g., USGS quadrangle or other map) with enough detail to identify the location of the facility and the receiving waters and locations where *stormwater* enters an *MS4*, if applicable, within one mile of the facility.

6. *Site Map*

A site map identifying the following:

- a. Property boundaries and size in acres;
- b. Location and extent of significant structures (including materials shelters), and impervious surfaces;

² This may also include releases of petroleum or hazardous substances that are not in excess of reporting quantities but which may still cause or contribute to significant water quality impairment. For example, the reportable quantity for ammonia is listed to be 100 pounds and releases well below this threshold will cause water quality impairment and must be addressed.

- c. Location of each *outfall* labeled with the *outfall* identification, including *outfalls* with *discharges* authorized under other *SPDES* permits;
- d. The approximate outline of the drainage area to each *outfall*;
- e. Locations of haul and access roads;
- f. Rail cars and tracks;
- g. Arrows showing direction of *stormwater* flow;
- h. Location of all receiving waters in the immediate vicinity of the facility, indicating if any of the waters are impaired and, if so, whether the waters have *TMDLs* established for them;
- i. Location of *MS4s* and where the *stormwater discharges* to them;
- j. Location of all *stormwater* conveyances including ditches, pipes, and swales;
- k. Locations where *stormwater* flows have significant potential to cause erosion;
- l. Location and source of run-on from adjacent property containing significant quantities of *pollutants* and/or volume of concern to the facility;
- m. Locations of the following areas where such areas are exposed to precipitation or *stormwater* run-on:
 - Fueling stations;
 - Vehicle and equipment maintenance and/or cleaning areas;
 - Loading/unloading areas;
 - Locations used for the treatment, storage or disposal of wastes;
 - Liquid storage tanks;
 - Processing and storage areas;
 - Locations where significant materials, fuel or chemicals are stored and transferred;
 - Locations where vehicles and/or machinery are stored when not in use
 - Transfer areas for substances in bulk;
 - Locations of potential *pollutant* sources identified under Part III.A.3;
 - Location and description of non-*stormwater discharges* listed in Part I.B.2;
 - Locations where major spills or leaks identified under Part III.A.4 have occurred;
 - Locations of all *stormwater* monitoring points;

- Locations of all existing structural *BMPs*.

7. *Stormwater Controls*

The SWPPP must document in writing the location and type of *BMPs* installed and implemented at the facility to achieve the non-numeric effluent limits in Part II.A and where applicable in Part VII, and the sector specific numeric *effluent limitations* in Part VII. The SWPPP shall describe how each *BMP* is being implemented for all the potential *pollutant* sources identified in Part III.A.3.

If the *owner or operator* determines that any of the *BMPs* described in Part II.A, or any sector-specific *BMPs* in Part VII, are not appropriate for the facility, a written explanation of why they are not appropriate shall be included in the SWPPP. If new or innovative *BMPs* not listed in this permit are being used, descriptions of them shall be included in this section of the SWPPP.

- a. **Good Housekeeping** - The SWPPP must describe all good housekeeping practices that are being implemented by the *owner or operator* including those described in Part II.A.2 to *minimize pollutant discharges* from all exposed areas that are potential sources of *pollutants*.
- b. **Facility inspections** - The SWPPP must describe procedures for scheduling, completing and recording results of routine and comprehensive site inspections at frequencies meeting or exceeding those specified in Part IV of this permit.
- c. **Maintenance and Repair**
 - (1) The SWPPP must describe a preventative maintenance program that includes timely inspection, maintenance and repairs of all industrial equipment and systems.
 - (2) The SWPPP must describe a preventative maintenance program that includes timely inspection, maintenance and repairs of structural and non-structural *BMPs*.
 - (3) The SWPPP must describe inspection and maintenance procedures for baghouses to prevent the escape of dust from the system and the immediate removal of accumulated dust at the base of the exterior baghouse.
 - (4) The SWPPP must include procedures for catch basin cleaning.
- d. **Spill Prevention and Response Procedures**
 - (1) The SWPPP must describe the procedures that will be followed for cleaning up spills or leaks. The procedures and necessary spill response equipment must be made available to those employees who may cause or detect a spill or leak.

- (2) The SWPPP must describe procedures for notification of the appropriate facility personnel, emergency response agencies, and regulatory agencies when a leak, spill, or other release occurs. If possible, one of these individuals should be a member of the *stormwater* pollution prevention team (see Part III.A.1).
- e. **Employee Training and Education** - The SWPPP must describe the *stormwater* training program required for individuals conducting *industrial activity* at the facility. The description must include:
- (1) The specific training given (see Part II.A.8.d)
 - (2) The target audience (e.g. employees in positions responsible for specific tasks, club members performing engine repair, etc.).
 - (3) Identify periodic dates for such training (e.g., annually, every six months during the months of July and January). An annual signed and dated employee training log must be kept in the SWPPP.
- f. **Document Non-Stormwater Discharges** - Non-*stormwater discharges* listed in Part I.B.2 must have the following information documented:
- (1) **Discharge Certification** - The SWPPP must include a certification that all *discharges* have been tested or evaluated for the presence of non-*stormwater discharges*. A copy of the certification must be included in the SWPPP at the facility. The certification must include:
 - (a) The date of any testing and/or evaluation;
 - (b) Identification of potential significant sources of non-*stormwater discharges* at the site;
 - (c) A description of the results of any test and/or evaluation for the presence of non-*stormwater discharges*;
 - (d) A description of the evaluation criteria or testing method used; and
 - (e) A list of the *outfalls* or on-site drainage points that were directly observed during the test.
 - (2) **Detail Non-Stormwater Discharges** - The sources of non-*stormwater discharges* listed in Part I.B.2 are authorized *discharges* under this permit provided the *owner or operator* includes the following information in the SWPPP:

- (a) Identification of each authorized non-*stormwater* source (flows from emergency/unplanned firefighting activities do not need to be identified);
 - (b) The location where the non-*stormwater discharge* is likely to occur;
 - (c) Descriptions of appropriate BMPs for each source; and
 - (d) If mist blown from cooling towers is included as one of the authorized non-*stormwater discharges* from the facility, the *owner or operator* must specifically evaluate the potential for the *discharges* to be contaminated by chemicals used in the cooling tower and must select and implement BMPs to control such *discharges* so that the levels of cooling tower chemicals in the *discharges* would not cause or contribute to a violation of an applicable water quality standard.
- g. The SWPPP must describe *BMPs* selected to eliminate *discharges* of solid materials, including waste, garbage and floating debris, to *surface waters of the State*, except as authorized by a permit issued under section 404 of the CWA.
 - h. The SWPPP must describe *BMPs* selected to *minimize* off-site vehicle tracking of raw, final, or waste materials or sediments, and the generation of dust. Tracking or blowing of raw, final, or waste materials from areas of *no exposure* to exposed areas must be *minimized*.
 - i. The SWPPP must describe *BMPs* selected to stabilize exposed areas and contain runoff using structural and/or non-structural *control measures* to *minimize* onsite erosion and sedimentation, and the resulting *discharge* of *pollutants*.
 - (1) The SWPPP shall identify areas at the facility which, due to topography, land disturbance (e.g., construction) or other factors, have potential for significant soil erosion.
 - (2) The SWPPP must identify structural, vegetative, and/or stabilization *BMPs* that will be implemented to limit erosion.
 - (3) Velocity dissipation devices (or equivalent measures) must be placed at *discharge* locations and along the length of any *outfall* channel if they are necessary to provide a non-erosive flow velocity from the structure to a water course.
 - (4) The SWPPP must contain adequate details to demonstrate that controls conform to the New York Standards and Specifications for

Erosion and Sediment Control (2016), or equivalent. This document is available at: <http://www.dec.ny.gov>

- j. The SWPPP shall describe the traditional *stormwater* management practices (permanent structural *BMPs*) that currently exist or that are planned for the facility. These types of *BMPs* are typically used to divert, infiltrate, reuse, or otherwise reduce *pollutants* in *stormwater discharges* from the site. Examples of *BMPs* that could be used include but are not limited to: *stormwater* detention structures (including wet ponds); green infrastructure practices; *stormwater* retention structures; flow attenuation by use of open vegetated swales and natural depressions; and onsite infiltration of runoff.

The SWPPP shall provide that all *stormwater* management practices that the *owner or operator* determines to be reasonable and appropriate, or are required by a *State* or local authority, shall be implemented and maintained. Factors for the *owner or operator* to consider when selecting appropriate *BMPs* should include:

(1) The industrial materials and activities that are exposed to *stormwater*, and the associated *pollutant* generating potential of those materials and activities; and

(2) The beneficial and potential detrimental effects on surface water quality, ground water quality, receiving water base flow (dry weather stream flow), and physical integrity of receiving waters. Structural measures shall be placed on upland soils, avoiding wetlands and floodplains, if possible. Structural *BMPs* may require a separate permit under section 404 of the CWA before installation begins.

- k. The SWPPP must document that all storage piles of salt used for deicing or other commercial or industrial purposes are enclosed or covered to prevent exposure to precipitation, except during active operations to add or remove materials from the pile.

For a salt storage facility, the SWPPP must document all good housekeeping measures in place to assure that salt spilled during transfer and spilled or tracked along haul and access roads is removed and returned to the covered storage pile.

- l. The SWPPP must document the location and type of *BMPs* installed and implemented at the facility to achieve the non-numeric effluent limits stipulated in Part II.A and any relevant sector-specific section(s) of Part VII of this permit.

- m. The SWPPP must document the location and type of BMPs installed and implemented at the facility to achieve and address any applicable effluent limitations based in the activity-specific section(s) of Part VII, which are summarized in the table in Appendix D of this permit.

8. Monitoring and Sampling Data

The SWPPP must include:

- a. A summary of existing *stormwater discharge* sampling data taken at the facility;
- b. Chain of Custody Records for samples collected and transported to an approved laboratory;
- c. Laboratory reports of results of sample analysis;
- d. Quarterly Visual Monitoring Reports;
- e. Copies of semi-annual *Discharge Monitoring Reports (DMRs)*;
- f. Copies of *Annual Certification Reports (ACR)*;
- g. A summary of all *stormwater* sampling data collected during the term of this permit;
- h. Any monitoring waivers that have been claimed.

9. Copy of Permit Requirements

The *owner or operator* must maintain a copy of the permit with the SWPPP. The NOI Authorization Letter and all NOIs (including modifications) must be maintained with the SWPPP.

10. Inspection Schedule & Documentation

The SWPPP shall contain the schedule for conducting inspections and all documentation resulting from the inspection.

11. Corrective Action Documentation

The SWPPP shall contain all corrective action documentation as detailed in Part V.C.

B. SWPPP Preparer

- 1. The Owner or Operator shall have a *qualified person* prepare the SWPPP. . This plan does not necessarily have to be developed or certified by a licensed Professional Engineer; however all components of the SWPPP that involve the practice of engineering, as defined by the NYS Education Law (see Article 145), shall be prepared by, or under the direct supervision of a professional engineer licensed to practice in the State of New York.

2. Erosion and Sediment Control plans needed to stabilize exposed areas and control runoff per Part II.A.5 or to meet sector specific requirements shall be prepared by, a *qualified person* who is knowledgeable in the principles and practices of erosion and sediment control.
3. The design of post-construction *stormwater* management controls as defined in the SPDES General Permit for *Stormwater Discharges from Construction Activity (GP-0-15-002)*, needed to manage runoff per Part II.A.6 or meet sector specific requirements shall be prepared by a *qualified professional*.

C. Signature and Stormwater Pollution Prevention Plan Availability

1. Signature/Location - The SWPPP shall be signed in accordance with Appendix H.8 and retained on-site at the facility in accordance with Parts III.A.9 and VI.C. For inactive facilities, the SWPPP may be kept at the nearest office of the *owner or operator*. Failure to keep a copy of the SWPPP as specified above is a violation of the permit.
2. Availability
 - a. The *owner or operator* must make a copy of the SWPPP available to the *Department* for review at the time of an on-site inspection.
 - b. The *owner or operator* must furnish a copy of the SWPPP within five (5) business days of a *Department* request in accordance with Appendix H.6.
 - c. The *owner or operator* must make a copy of the SWPPP available to the public within fourteen (14) days of receipt of a written request. Copying of documents will be done at the requester's expense. (Note: A facility may withhold justifiable portions of the SWPPP from public review that contain trade secrets, confidential commercial information or critical infrastructure information in accordance with 6 NYCRR 616.7 and 750-1.22).

D. Special SWPPP Requirements

The following additional requirements are applicable for each special circumstance:

1. *Stormwater discharges* into or through *MS4s*.
 - a. Facilities covered by this permit must comply with applicable requirements in municipal *stormwater* management programs developed under the *SPDES* permit issued for the *discharge* from the *MS4* that receives the facility's *discharge*, provided that the *owner or operator* has been notified of such conditions.
 - b. *Owners or operators* that *discharge* through an *MS4*, or a municipal system designated by the *Department* shall make their SWPPP available to the municipal operator of the *MS4* upon request.

2. *Stormwater discharges associated with industrial activity to impaired waterbodies.*

Facilities that are discharging to an *impaired waterbody* and the cause of the impairment is a *pollutant* of concern included in the *benchmarks* and/or numeric effluent limitations (see Appendix G) to which the facility is subject must include the following in their SWPPP:

- a. Identification of Impaired Waterbody – Identify any *impaired waterbody* that may receive *stormwater discharges associated with industrial activity* from the facility and the cause of the waterbody's impairment.
- b. Pollutant(s) of Concern – A list of *pollutant(s)* or *pollutant parameter(s)* that have been handled, treated, stored or disposed of in a manner that would create the reasonable potential for the *pollutant* of concern causing the impairment to be *discharged*.
- c. Potential for Presence in Stormwater – Identify each area of the facility that generates *stormwater discharges associated with industrial activity* with a reasonable potential to *discharge* the *pollutant(s)* of concern. Factors to consider include the likelihood of the *industrial activity* producing the *pollutant(s)* of concern to have contact with *stormwater* and a history of *reportable* leaks or spills that could result in the *pollutant(s)* of concern being *discharged* to the *impaired waterbody*.
- d. Stormwater Controls – The SWPPP shall include a description of the type and location of existing and planned *BMPs* selected for each of the areas where the *pollutant(s)* of concern are exposed to *stormwater*. *BMPs* shall be selected to *minimize* the *pollutant(s)* of concern from being *discharged* to the *impaired waterbody* and should take into consideration all *stormwater* controls listed in Part III.A.7. The SWPPP shall describe how each *BMP* will be implemented for all the areas where the *pollutant(s)* of concern will be exposed to *stormwater*.

E. Keeping SWPPPs Current

The *owner or operator* shall amend the SWPPP whenever:

1. There is a change in design, construction, operation, or maintenance at the facility which may have an effect on the potential for the *discharge* of *pollutants* from the facility which has not otherwise been addressed in the SWPPP; or
2. It is found to be ineffective in eliminating or significantly minimizing *pollutants* from sources identified under Part III.A.3 or is otherwise not achieving the goals or requirements of this permit. The SWPPP shall be modified, and additional monitoring and analysis shall be completed as follows:

a. SWPPP Modifications

- (1) Maps or description of industrial activities – If the SWPPP has been found to be inaccurate or incomplete, modifications must be completed to correct the deficiencies identified.
- (2) *Stormwater* controls - The modification must identify the corrective actions needed and include a schedule for the implementation with a final date no later than 12 weeks unless the *Department* approves additional time in writing.
- (3) Additional inspections monitoring and/or analysis - If the results of inspections, monitoring and/or analysis reveal a violation of this permit, a failure to maintain eligibility for coverage under this permit or a failure to comply with the *benchmarks* or other action levels in this permit, additional inspections, monitoring and/or laboratory analysis of *stormwater* samples may be required. Such requirements are set forth in the applicable Parts.

Part IV – Inspections and Monitoring

A. Comprehensive Site Compliance Inspection & Evaluation

The *owner or operator* shall conduct a comprehensive site compliance inspection at least once per year. The inspections must be done by a *qualified person* who may be either a facility employee or outside consultant hired by the facility. The inspector must be familiar with the *industrial activity*, the *BMPs*, the SWPPP, and must possess the skills to assess conditions at the facility that could impact *stormwater* quality and assess the effectiveness of the *BMPs* that have been chosen to control the quality of the *stormwater discharges*. If more frequent inspections are conducted, the SWPPP must specify the frequency of inspections.

1. Scope of the Compliance Inspection & Evaluation

- a. Inspections must include all areas where industrial materials or activities are exposed to *stormwater*, as identified in Part III.A.3, and areas where unauthorized discharges spills and leaks have occurred within the past three years. At a minimum the inspection shall identify or include:
 - (1) Industrial materials, residue or trash on the ground that could contaminate or be washed away in *stormwater*;
 - (2) Leaks or spills from industrial equipment, drums, barrels, tanks or similar containers;
 - (3) Examination of all *outfall* locations, to determine the presence of unauthorized non-*stormwater discharges* or authorized non-*stormwater discharges* that are not certified in accordance with Part III.A.7(f)(1);
 - (4) Off-site tracking of industrial materials or sediment where vehicles enter or exit the site;
 - (5) Tracking of material away from the area where it originates including from areas of *no exposure* to exposed areas;
 - (6) Evidence of, or the potential for, *pollutants* entering or discharging from the drainage system;
 - (7) Inspection of areas found to be the source of *pollutants* observed during visual and analytical monitoring done during the year;
 - (8) *Stormwater* BMPs identified in the SWPPP must be observed to ensure that they are operating correctly.

- b. If the Comprehensive Site Compliance Inspection indicates the presence of *stormwater* pollution (e.g., color, odor, floating solids, settled solids, suspended solids, foam, oil sheen, or other indicators), the *owner or operator* must, implement corrective actions in Part V.

2. **Compliance Inspection & Evaluation report**

- a. A compliance inspection & evaluation report must be made and retained as part of the SWPPP for a period of at least five (5) years from the date of the report. At a minimum, the report must include:
 - (1) The scope of the inspection (Part IV.A.1),
 - (2) The name(s) of the person(s) conducting the inspection,
 - (3) The date(s) of the inspection,
 - (4) Weather information at the time of the inspection,
 - (5) Major observations relating to the implementation of the SWPPP, including:
 - (a) The location(s) of *discharges of pollutants* from the site;
 - (b) The location(s) of previously unidentified *discharges of pollutants* from the site;
 - (c) Any evidence of, or the potential for, pollutants entering the drainage system;
 - (d) The source of any discharges and actions taken to address newly identified authorized non-stormwater discharges or elimination of non-authorized discharges;
 - (e) Location(s) of BMPs that need to be maintained;
 - (f) Location(s) of BMPs that failed to operate as designed or proved inadequate for a particular location;
 - (g) Location(s) where additional BMPs are needed that did not exist at the time of inspection;
 - (h) Any incidents of noncompliance. Where an inspection does not identify any incidents of noncompliance, the report shall contain a certification that the facility is in compliance with the SWPPP and this permit;

- (i) Observations regarding the physical condition of and around all outfalls, including any flow dissipation devices; and evidence of pollutants in discharges and/or the receiving water; and,
 - (j) The required corrective actions to be implemented in accordance with Part V.
- b. Credit as a Routine Facility Inspection - Where compliance inspection schedules overlap with routine inspections required under Part IV.B, the comprehensive site compliance inspection may be used as one of the routine inspections.

B. Routine Inspections of BMPs

1. In addition to or as part of the comprehensive site inspection, a *qualified person* must perform routine inspections which include all areas of the facility where industrial materials or activities are exposed to precipitation or *stormwater runoff*. The inspection frequency shall be on a quarterly basis or as specified in the facility's applicable industrial sector in Part VII.
2. The routine inspection must evaluate the performance of *stormwater* BMPs described in the SWPPP.
3. The routine inspection shall be documented and shall be kept with the SWPPP.
4. Any deficiencies in the implementation and/or adequacy of the BMPs must be documented. The required corrective actions must be implemented in accordance with Part V.

C. Annual Dry Weather Flow Inspection

In addition to or as part of the Comprehensive Site Compliance Inspection (Part IV.A), a qualified person must perform an annual dry weather flow inspection and update the non-stormwater discharge certifications (Part III.A.7.f (1)). The requirements and procedures for the annual dry weather flow inspection are applicable to all facilities covered under this permit, regardless of the facility's sector of industrial activity.

1. The *owner or operator* must perform and document at least one dry weather flow inspection each year after at least three (3) consecutive days of no precipitation. The annual dry weather flow inspection shall be conducted to determine the presence of non-stormwater *discharges* to the stormwater drainage system.
2. The annual dry weather flow inspection shall be documented in an inspection report which must include the *outfall* locations, the inspection date and time, inspector name, description of *discharges* identified, the source of any

discharges and actions taken to address any newly identified allowable non-stormwater *discharges* or elimination of non-authorized *discharges*.

3. If a non-stormwater discharge not previously certified in accordance with Part III.A.7.f (1) is discovered the *owner or operator* must implement corrective actions in Part V.B.
4. The dry weather flow inspection report and updated non-stormwater discharge documentation required by Part III.A.7.f (1) must be retained on-site with the SWPPP.

D. Collection and analysis of samples

Samples must be collected as follows:

1. When to Sample

A sample must be taken of the *stormwater discharge* resulting from a *qualifying storm event* with at least 0.1 inch of precipitation (defined as a *measurable storm event*), providing the interval from the preceding measurable storm is at least 72 hours. Each outfall must be sampled except for any outfall for which the facility has claimed a representative outfall waiver in accordance with Part IV.G.3. In the case of snowmelt, samples must be taken during a period with a *discharge* from the site.

The sample must be taken during the first 30 minutes (or as soon as practical, but not to exceed one hour) of the *discharge* at the *outfall*. If the sampled *discharge* mixes with non-*stormwater* water, the *owner or operator* must attempt to sample the *stormwater discharge* prior to mixing.

2. Sample Analysis

- a. Monitoring and analysis must be conducted according to test procedures approved under 40 CFR Part 136, or equivalent, unless other test procedures have been specified in this permit.
- b. Any laboratory test or sample analysis required by this permit for which the *State Commissioner of Health* issues certificates of approval pursuant to section 502 of the Public Health Law shall be conducted by a laboratory that has been issued a certificate of approval (ELAP certified).
- c. The laboratory sample analysis reports must be kept with the SWPPP.

3. Storm event data

The storm event must be documented using the Storm Event Data Form provided by the *Department*. The Storm Event Data Form must be kept with the SWPPP.

4. Secondary Containment Screening and Sampling

Prior to each *discharge*³ from a secondary containment system the *stormwater* must be screened for contamination. (Note: All *stormwater* must be inspected for visible evidence of contamination.) Additional screening methods shall be developed by the *owner or operator* as part of the overall BMP Plan (e.g., the use of volatile gas meters to detect the presence of gross levels of gasoline or volatile organic compounds). If the screening indicates contamination, the *owner or operator* must collect and analyze a representative sample⁴ of the *stormwater*. If the sample contains no *pollutants*, the *stormwater* may be *discharged*. Otherwise it must either be disposed of in an onsite or off-site wastewater treatment plant designed to treat and permitted to *discharge* such wastewater. The first discharge following any cleaned up spill or leak must be sampled regardless of the screening results.

E. Quarterly Visual Monitoring

The requirements and procedures for quarterly visual monitoring are applicable to all facilities covered under this permit, regardless of the facility's *industrial activity*

1. The monitoring must be made at least once in each of the following quarters:
 - January 1st through March 31st,
 - April 1st through June 30th,
 - July 1st through September 30th, and
 - October 1st through December 31st
2. All samples must be collected from *discharges* resulting from a *qualifying storm event*, in accordance with Part IV.D.1.
3. The *owner or operator* must perform and document quarterly visual monitoring of a *stormwater discharge* associated with *industrial activity* from each *outfall* on the *Department* provided form and included with the SWPPP unless:
 - a. A waiver is submitted in accordance with Part IV.G, or
 - b. There is no *discharge* from a *qualifying storm event* during a monitoring period. If no *qualifying storm event* resulted in runoff from the facility during a monitoring quarter, documentation must be included with the

³ Note: Discharge includes stormwater discharges and snow and ice removal. If applicable, a representative sample of snow and/or ice should be collected and allowed to melt prior to assessment.

⁴ If the stored substance is gasoline or aviation fuel then sample for oil & grease, benzene, ethylbenzene, naphthalene, toluene and total xylenes (EPA method 602). If the stored substance is kerosene, diesel fuel, fuel oil, or lubricating oil then sample for oil & grease and polynuclear aromatic hydrocarbons (EPA method 610). In all cases an estimated discharge volume and pH monitoring is required.

SWPPP. If a visual examination was performed and the storm event was later determined not to be a measurable storm event, the visual examination must be included with the SWPPP.

4. When the *outfall discharges* directly to the *surface waters of the State*, the *discharge* must be inspected to see whether *BMPs* are effective in preventing significant impacts to receiving waters.
5. Laboratory sample analysis is not necessary to fulfill the visual monitoring requirements.
6. If the visual monitoring indicates the presence of *stormwater* pollution (e.g., color, clarity, odor, floating solids, settled solids, suspended solids, foam, oil sheen, or other indicators), the *owner or operator* must implement corrective actions in Part V.

F. Monitoring Requirements

The monitoring requirements that apply to a facility depends on the types of industrial activities generating *stormwater* runoff. The *owner or operator* must review this Part and Part VII as well as Appendices C, D, E and G of this permit to determine which monitoring requirements apply to each individual *outfall*.

- At facilities where more than one *industrial activity* occurs, monitoring requirements apply for all parameters specific to those industrial activities.
- Where more than one numeric limitation for a specific parameter applies to a *discharge*, compliance with the more restrictive limitation is required.
- Where monitoring requirements for a monitoring period overlap (e.g., need to monitor TSS twice/year for numeric effluent limitation monitoring and also twice/year for *benchmark monitoring*), a single sample will satisfy both monitoring requirements.

1. Types of Pollutant Monitoring

- a. *Benchmark Monitoring* is intended to provide a guideline for the *owner or operator* to determine the overall effectiveness of the SWPPP in controlling the *discharge* of *pollutants* to receiving waters. The requirements for *benchmark monitoring* apply to *discharges* associated with specific industrial activities identified in Part VII (summarized in Appendix C).
- b. *Numeric Effluent Limitation* Monitoring – Activity specific effluent limitations specified in Part VII (summarized in Appendix D).
- c. *Discharges* to Impaired Waterbodies – If a facility *discharges* to an *impaired waterbody* and the cause of impairment is a *pollutant* of concern included in the benchmarks and/or numeric effluent limitations to which

the facility is subject to in Part VII, the facility is required to conduct the additional sampling requirements detailed in Part IV.F.2 for that particular *pollutant(s)* only. The compliance monitoring for *discharges* to impaired waterbodies is in addition to any applicable sector specific *Benchmark Monitoring* in Part IV.F.1.a and Numeric Effluent Limit Monitoring in Part IV.F.1.b. A summary of the applicable benchmarks and/or numeric effluent limits associated with the *pollutant* of concern to an *impaired waterbody* and their applicable sector is located in Appendix G.

- d. Coal Pile Runoff Monitoring - Facilities with *discharges* of *stormwater* from coal storage piles must comply with the limitations and monitoring requirements of Table IV.3 for all *discharges* containing the coal pile runoff, regardless of the facility's sector of *industrial activity*.
- e. Secondary Containment at Storage and Transfer Areas - Unless the *discharge* from any containment system outlet is permitted by an *individual SPDES permit* as an *outfall* with explicit effluent and monitoring requirements, the *owner or operator* shall monitor the outlet as follows:
 - (1) Storage Area Secondary Containment Systems - The volume of each *discharge* from each outlet must be monitored. A representative sample shall be collected of the first *discharge* following any cleaned up spill or leak. The sample must be analyzed for pH, the substance(s) stored within the containment area and any other *pollutants* the *owner or operator* knows or has reason to believe are present.
 - (2) Transfer Area Secondary Containment Systems - The first *discharge* following any spill or leak must be sampled for flow, pH, the substance(s) transferred in that area and any other *pollutants* the *owner or operator* knows or has reason to believe are present.

2. Frequency and Timing of Monitoring

The monitoring requirements for each type of monitoring are provided in Table IV.1 below:

Table IV.1 Monitoring Requirements			
Type of Monitoring	Applicability	Frequency	Reported to the Department
Quarterly Visual Monitoring	All Facilities	Quarterly	No
<i>Benchmark Monitoring, Numeric Effluent Limitation Monitoring, Coal Pile Runoff</i>	Sector Specific	Semi-Annual	Yes
Secondary Containment at Storage and Transfer Areas	Sector Specific	As needed	No
<i>Discharges to Impaired Waterbodies</i>	Waterbody Specific	Quarterly	Yes

The monitoring periods for required monitoring are provided in the Table IV.2 below:

Table IV.2 Monitoring Periods	
Monitoring Frequency	Monitoring Periods
Semi-Annual	Period 1 - January 1 st through June 30 th
	Period 2 - July 1 st through December 31 st
Quarterly	Quarter 1 – January 1 st through March 31 st
	Quarter 2 – April 1 st through June 30 th
	Quarter 3 – July 1 st through September 30 th
	Quarter 4 – October 1 st through December 31 st

- a. If a facility's permit coverage was effective less than two months from the end of a monitoring period, monitoring begins with the next monitoring period.
- b. If a facility is inactive for an entire monitoring period, it may claim a waiver in accordance with Part IV.G.

3. *Monitoring Requirements*

- a. The *owner or operator* must perform and document monitoring of *stormwater discharges* associated with *industrial activity* from each *outfall* during the monitoring periods listed in Table IV.2 unless:
 - (1) A waiver applicable to the specific type of monitoring is submitted in accordance with Part IV.G, or
 - (2) There is no *discharge* from a *qualifying storm event* during a monitoring period. If no *qualifying storm event* resulted in runoff from the facility during a monitoring period, documentation must be included with the SWPPP.

If a monitoring sample is collected during a storm event that is later determined not to be a qualifying storm event, the results should be included with the SWPPP.
- b. Collection and analysis of samples must be done in accordance with Part IV.D.
- c. Evaluation of Results of Analysis - The *owner or operator* must refer to the tables found in the individual sectors in Part VII for *benchmark monitoring cut-off concentrations* and numeric effluent limitations.
 - (1) An exceedance of a Benchmark cut-off concentration is not a permit violation. The exceedance(s) requires the *owner or operator* to evaluate potential sources of *stormwater* contaminants at the facility and perform corrective actions in accordance with Part V.
 - (2) An exceedance of a Numeric *Effluent Limitation* is a permit violation. If there is an exceedance of one or more parameters the *owner or operator* must perform corrective actions in accordance with Part V.
- d. Recording and Reporting Results
 - (1) Results of Benchmark and Numeric Effluent Limitation monitoring, (including coal pile runoff monitoring), must be reported to the *Department* using a *Discharge Monitoring Report (DMR)* and included with the SWPPP.
 - (2) Results of monitoring of *discharges* from secondary containment systems must be included with the SWPPP, but are not reported to the *Department*.
- e. For monitoring of Coal Pile Runoff, the *owner or operator* must refer to Table IV.3 for numeric effluent limitations.

Table IV.3			
Numeric Limitations for Coal Pile Runoff			
Parameter	Limit	Monitoring Frequency	Sample Type
Total Suspended Solids (TSS)	50 mg/l, daily max	Semi-Annual	Grab
pH	6.0 - 9.0 min. and max	Semi-Annual	Grab

- (1) The coal pile runoff must not be diluted with *stormwater* or other flows in order to meet this limitation.
- (2) If a facility is designed, constructed and operated to treat the volume of coal pile runoff that is associated with a 10-year, 24-hour rainfall event, any untreated overflow of coal pile runoff from the treatment unit is not subject to the 50 mg/L limitation for total suspended solids.

G. Monitoring Waivers

Unless stated otherwise, the following waivers may be applied to any monitoring required under this permit.

1. Adverse Climatic Conditions Waiver - Adverse weather conditions are those that are dangerous or create inaccessibility for personnel. This waiver may be claimed if the only qualifying storm event(s) in a monitoring period created dangerous conditions for personnel, created conditions which made the sample location inaccessible or made collection of a sample impossible. Examples of these conditions include but are not limited to local flooding, high winds and electrical storms. This waiver may not be claimed to indicate that samples were not collected due to inconvenient timing of storms or other failures to collect *stormwater* samples.

If the Adverse Climatic Conditions Waiver is claimed, an Adverse Climatic Conditions Waiver Form must be signed and submitted to the *Department* with any associated *ACR* or *DMR* in accordance with Appendix H.8 and included with the SWPPP.

2. Inactive and unstaffed sites - An annual Comprehensive Site Inspection (Part IV.A) can be waived at a facility that is inactive and unstaffed for the entire monitoring period if no industrial materials or activities are exposed to *stormwater*. Facilities covered under Sector J are not required to meet the requirement that no materials are exposed to *stormwater*; however adequate *stormwater* controls must be in place to prevent migration of contaminated *stormwater* to surface water. To claim this waiver, the *owner or operator* must:

- a. Maintain a certification with the SWPPP stating the dates the site is inactive and unstaffed;
 - b. Perform and document a Comprehensive Site Inspection prior to shut down. The inspection report must be included in the SWPPP. The certification must include the results of this inspection; and,
 - c. Complete an Inactive or Unstaffed Waiver Form. When this waiver is being claimed, the waiver form must be signed and submitted with each ACR or DMR and be included with the SWPPP.
3. Representative outfalls - If a facility has two or more *outfalls* that have substantially identical *discharges*, the *owner or operator* may sample the *discharge* of one of the *outfalls* and report that the analytical data also applies to the substantially identical *outfall(s)*. Whether or not *discharges* are substantially identical is determined by the similarity of the industrial activities and exposed materials occurring within the drainage area of each *outfall*.
- a. The *owner or operator* must collect a sample from the anticipated "worst case" *outfall*. This is determined by looking at the following indicators:
 - (1) Size of drainage area;
 - (2) Level of *industrial activity*;
 - (3) Amount of exposed industrial materials.
 - b. A representative *outfall* waiver may not be claimed at *outfalls* with *discharges* associated with different industrial activities. This representative *outfall* waiver applies to quarterly visual monitoring and *benchmark monitoring*. It cannot be claimed for compliance monitoring for *discharges* subject to *effluent limitation guidelines* or to *discharges* to *impaired waters*.
 - c. When this waiver is being claimed, the *owner or operator* must submit a completed Representative Outfall Waiver Form with the NOI and keep it with the SWPPP.
 - d. If there is an event that triggers corrective actions at an *outfall* that represents other substantially identical *outfalls*:
 - (1) corrective actions must be completed for all *outfalls* covered by the waiver;

- (2) The representative outfall waiver is suspended and quarterly visual monitoring and benchmark monitoring of the substantially identical outfalls shall commence immediately; and,
- (3) Unless otherwise notified by the Department, the representative outfall waiver again applies when:
 - (a) The results of two consecutive monitoring periods reported to the Department show that all outfall have had no exceedances of benchmark monitoring cut-off concentrations for all parameters; and,
 - (b) The owner or operator submits a new Representative Outfall Waiver Form to the Department.

Part V - Corrective Actions

Failure to document and take the necessary corrective actions are violations of the permit. Continued exceedance of benchmark cut-off concentrations and/or numeric effluent limitations may identify facilities that would be more appropriately covered under an *individual SPDES permit*. If there is an exceedance of either a benchmark or numeric effluent limit at an outfall where a representative outfall waiver has been claimed, the waiver no longer applies and corrective actions must be performed on all outfalls covered by the waiver (Part IV.G.3.d).

A. For Stormwater Discharges

When the visual examination indicates the presence of pollution or when the benchmark or numeric effluent limit sample results indicate exceedances of the *pollutants*, the *owner or operator* must:

1. Inspect the facility for potential sources of *stormwater* contamination and/or causes of the exceedance to numeric limits;
5. Implement additional non-structural and/or structural BMPs to address any sources of contamination that are identified to prevent recurrence within the following timeframes:
 - a. The implementation must be completed before the next anticipated storm event, if practicable, but not more than 12 weeks after discovery.
 - b. If implementation will take longer than 12 weeks, the *owner or operator* must submit a proposed schedule for completion of the project and obtain a written approval from the *Regional Water Engineer (Appendix F)*
6. Revise the facility's SWPPP in accordance with Part III.E; and,
7. Continue efforts to implement additional BMPs at the facility if corrective actions do not result in achieving *benchmark monitoring cut-off concentrations* and/or numeric effluent limitations.

B. For Non-Stormwater Discharges

1. If a non-*stormwater discharge* is discovered the *owner or operator* must:
 - a. Identify its source and determine whether it is an authorized *discharge*.
 - (1) Upon determination that the *discharge* is not covered under this permit or another SPDES permit, the *owner or operator* shall notify the Regional Water Engineer (Appendix F), of the unauthorized *discharge* and begin immediate actions to eliminate the *discharge*. These actions must be documented in the SWPPP.

- b. Upon determination that the *discharge* is an authorized non-*stormwater discharge* identified in Part I.B.2 that were not previously certified in accordance with Part III.A.7.f (1), the *owner or operator* shall update the discharge certification and keep with the SWPPP.

C. Corrective Action Documentation

Owners or operators must document the existence of any of the conditions listed in Parts V.A or V.B within 24 hours of becoming aware of such condition. Unless required by Part VI.A.2.b or as requested by the Department, the corrective action documentation is not required to be submitted and should be kept with the facility's SWPPP. Include the following information in your documentation:

- a. A description of the condition triggering the need for corrective actions. For any spills or leaks, include the following information: a description of the incident including material, date/time, amount, location, and reason for spill, and any leaks, spills or other releases that resulted in discharges of pollutants to waters of the state, through stormwater or otherwise;
- b. Date the condition was identified;
- c. The date when each corrective action was initiated and completed (or is expected to be completed);
- d. A description of the corrective actions to minimize or prevent the discharge of pollutants. For any spills or leaks, include response actions, the date/time clean-up completed, notifications made, and staff involved. Also include any control measures taken to prevent the reoccurrence of such releases (see Part II.A.4); and
- e. A statement, signed and certified in accordance with Appendix H.8.

Part VI – Reporting and Retention of Records

A. Reporting to the *Department*

1. *Annual Certification Report (ACR)*

- a. An *owner or operator* of a facility must submit an ACR, which is signed in accordance with Appendix H.8, to the *Department*.
 - (1) Prior to December 20, 2020, the *owner or operator* may elect to submit the ACR by mailing a paper form to the address listed in Part VI.A.4 or by using the *Department's* online ACR.
 - (2) Beginning December 21, 2020 and in accordance with the EPA's *NPDES* Electronic Reporting Rule, the *owner or operator* must submit the ACR electronically using the *Department's* online ACR. Both versions of the ACR are located on the *Department's* website (<http://www.dec.ny.gov/>).
- b. The ACR is the primary mechanism for reporting compliance with permit conditions to the *Department*. Every facility covered by this general permit must complete and submit an ACR form in accordance with the deadlines below:
 - (1) Owners or operators must complete and submit an ACR covering January 1 to December 31. This ACR must be received by the Department on an annual basis by January 28 of the following calendar year except:
 - (a) For facilities whose initial permit coverage is effective prior to October 1 of a calendar year, the initial ACR will cover the effective coverage date to December 31. This initial ACR must be received by the Department by January 28 of the following calendar year. Subsequent ACRs must be submitted in accordance with Part VI.A.1.b.(1).
 - (b) For facilities whose initial permit coverage is effective after October 1 of a calendar year, the initial ACR will cover January 1 to December 31 of the following calendar year. This initial ACR must be received by the Department by January 28 of the next year. Subsequent ACRs must be submitted in accordance with Part VI.A.1.b.(1).

2. *Discharge Monitoring Report (DMR)*

- a. The owner or operator with Benchmark and/or Numeric Effluent Limitation monitoring requirements shall electronically submit the results of the analysis using EPA's electronic DMR reporting system. All DMRs must be

received by the Department 28 days after the end of the monitoring period. Monitoring periods can be found in Table IV.1.

- b. Using forms provided by the Department, the owner or operator must report the following information when there is an exceedance of a numeric effluent limit (non-compliance event) or exceedance of a benchmark cutoff concentration of the impairing POC for discharges to impaired waterbodies:

- (1) Description of the exceedance and its cause

- (2) Corrective actions taken to address the exceedance

- (3) Preventative (long term) corrective actions taken including any SWPPP modifications to prevent a future exceedance.

- (4) Corrective actions taken for all outfalls claiming the representative outfall waiver.

3. Additional reporting

- a. In addition to filing the ACRs and DMRs with the Department, and upon request of the MS4 Operator, owners or operators with at least one stormwater discharge associated with industrial activity through the MS4, must submit signed copies of ACRs and DMRs for those outfalls to the MS4 Operator.
- b. Any spill of a hazardous substance must be reported in accordance with 6 NYCRR 597.4. Any spill of Petroleum must be reported in accordance with 6 NYCRR 613.6 or 17 NYCRR 32.3. Notification must be reported to the NYSDEC Spills hotline (1-800-457-7362) within two hours after discovery. Additional notifications may be required for Federal level notification through the National Response Center (NRC) at 1-800-424-8802. Where a release of Hazardous Substances or Petroleum enters an MS4, the *owner or operator* shall also notify the *owner* of the MS4 within 2 hours after discovery.

4. Mailing Address

Paper submissions of reports or waivers allowed by this permit or regulation must be submitted to:

Stormwater Compliance Coordinator
NYSDEC, Bureau of Water Compliance
625 Broadway
Albany, New York 12233-3506

B. Monitoring Reporting Submission Deadlines

Every facility covered by this general permit must complete and submit all applicable monitoring reports by the submission deadlines listed in the table below.

Table VI.1 Monitoring/Report Submission Deadlines	
Monitoring type	Submission Deadline
Visual Monitoring	Retain documentation on-site with SWPPP.
Comprehensive Site Compliance Inspection	Retain documentation on-site with SWPPP.
<i>Annual Certification Report</i>	Report must be received in the <i>Department's</i> Central Office no later than January 28 of the year following the reporting period. (See Part VI.A.1)
Benchmark Monitoring, Coal Pile Run-off, Numeric <i>Effluent Limitation</i> Monitoring	<u>Period 1</u> - <i>DMR</i> must be received electronically using EPA's electronic reporting system no later than July 28 following the end of reporting Period 1 - January 1 to June 30.
	<u>Period 2</u> - <i>DMR</i> must be received electronically using EPA's electronic reporting system no later than January 28 following the end of reporting Period 2 - July 1 to December 31.
Monitoring for Bulk Storage and Loading/Unloading Areas	Retain documentation on-site with SWPPP.
<i>Discharge</i> from Secondary Containment	Retain logbook of <i>discharges</i> , including the screening method, results of screening; date, time and volume of each <i>discharge</i> ; and the personnel supervising each <i>discharge</i> .
Monitoring for <i>Discharges</i> to Impaired Waterbodies	<i>DMR</i> must be received electronically using EPA's electronic reporting system no later than 28 days following the end of the reporting period. See Tables IV.1 and IV.2
Non-Compliance Event Form for Exceedances of Numeric Effluent Limits	Results of the exceedance(s) and corrective action(s) taken must be reported on the Non-Compliance Event Form provided by the Department with the submission of the <i>DMR</i> which reports the exceedance. (Part VI.A.2.b)
Corrective Action Documentation for facilities that do not discharge to an impaired waterbody	Retain documentation on-site with SWPPP. (Part V.C)
Corrective Action Form for facilities that have an exceedance of a Benchmark cut-off concentration to an impaired waterbody	Results of the exceedance(s) and corrective action(s) taken must be reported on the Corrective Action Form provided by the Department with the submission of the <i>DMR</i> which reports the exceedance. (Part VI.A.2.b)

C. Retention of Records

All records required by this permit must be retained to meet the timeframes specified below:

1. Administrative Records

The *owner or operator* must retain a copy of the NOI, NOT, Acknowledgment Letters and the SWPPP, for a period of at least five (5) years from the date that the *Department* receives a complete NOT submitted in accordance with Part I.E of this permit.

2. Monitoring Activities

The *owner or operator* shall retain records of all monitoring information for a period of at least 5 years from the date of the sample, measurement, report or application. This period may be extended by written request of the *Department*, provided that the extension is necessary to implement the provisions of this Part or *ECL* and that the reason or reasons for the extension are provided in the request.

- a. The monitoring information shall include:
 - (1) Records of all data used to complete the application for the permit;
 - (2) Copies of all reports required by this permit.
- b. Data to include with the records of monitoring information:
 - (1) The date, exact place, and time of sampling or measurements;
 - (2) The individual(s) who performed the sampling or measurements;
 - (3) The date(s) analyses were performed;
 - (4) The individual(s) who performed the analyses;
 - (5) The analytical techniques or methods used;
 - (6) The results of such analyses; and
 - (7) Quality assurance/quality control documentation.
- c. When records are stored electronically, the records must be preserved in a manner that reasonably assures their integrity and are acceptable to the *Department*. Such records must also be in a format which is accessible to the *Department*.
- d. The *owner or operator* shall make available to the *Department* for inspection and copying or furnish to the *Department* within 25 business days of receipt of a *Department* request for such information, any information retained in accordance with Part VI.C.2.a and b.

Part VII – Sector Specific Permit Requirements

The *owner or operator* must comply with the additional requirements of Part VII that apply to the specific *industrial activity* located at the *owner or operator's* facility. These requirements are in addition to the general requirements specified in the previous sections of this permit. The industry specific requirements are broken down into sections referred to as industrial sectors A through AC.

If the facility has more than one *industrial activity* meeting the description(s) of more than one sector occurring on-site, those industrial activities are considered to be *co-located*. *Stormwater discharges* from *co-located industrial activities* are authorized by this permit, provided that the *owner or operator* complies with any and all of the requirements applicable to each *industrial activity* at the facility. The monitoring and SWPPP terms and conditions of this permit are additive for *industrial activities* being conducted at a facility.

Examples of common *co-located industrial activities* include, but are not limited to:

- Timber Products (Sector A) and vehicle maintenance (Sector P)
- Auto salvage (Sector M) and auto recycling (Sector N)
- Mineral mining (Sector J) and maintenance of vehicles and equipment (Sector P)
- Mineral mining (Sector J) and asphalt manufacturing (Sector D)
- Mineral mining (Sector J) and concrete manufacturing (Sector E)
- Transfer stations accepting recyclables (Sector N) and maintenance of vehicles used in local trucking without storage (Sector P)
- Manufacturers of food and kindred products (Sector U) and maintenance of vehicles used in local or long distance trucking (Sector P)

Sector A – Timber Products

Applicability	<p>The requirements listed under this section apply to <i>stormwater discharges</i> associated with <i>industrial activity</i> from facilities generally classified under SIC Major Group 24 that are engaged in the following activities:</p> <ul style="list-style-type: none"> • Cutting timber and pulpwood (those that have log storage or handling areas); • Log sorting and log storage activities; • Mills, including merchant, lath, shingle, cooperage stock, planing, plywood and veneer; • Producing lumber and wood materials (including processing logs into woodchips); • Wood preserving; • Manufacturing wood buildings or mobile homes; and, • Manufacturing finished articles made entirely of wood or related materials, except for wood kitchen cabinet manufacturers (SIC Code 2434), which are addressed under Sector W. <p>The requirements of this section do <u>not</u> apply to active timber harvesting sites including the felling, skidding, preparation, loading and the incidental stacking and temporary storage of harvested timber on the harvest site prior to its initial transport to intermediate storage areas or other processing areas. An active harvest site is "considered to be an area where harvesting operations are actually on-going. Processing, sorting, or storage areas are not exempt if the site was used to store timber that was harvested from other sites.</p>	
Special Conditions	Prohibition of Non-Stormwater discharges	<p><i>Discharges of stormwater</i> from areas where there may be contact with chemical formulations sprayed to provide surface protection are not authorized by this permit. These <i>discharges</i> must be covered under a separate SPDES permit.</p>
	Authorized Non-Stormwater Discharges	<p><i>Discharges</i> from the spray down of lumber and wood product (wet decking) storage yards where no chemical additives are used in the spray down waters and no chemicals are applied to the wood during storage provided that such components are identified in the SWPPP in accordance with Part III.B.7.f <i>Discharges from Wet Decking</i> are subject to the Numeric <i>Effluent Limitations</i> in Table VII-A-1.</p>

SWPPP Requirements in Addition to Part III	
Site Map	<p>The site map shall identify where any of the following may be exposed to precipitation/surface runoff:</p> <ul style="list-style-type: none"> • Processing areas; • Treatment chemical storage areas; • Treated wood and residue storage areas; • Wet decking areas; • Dry decking areas; • Untreated wood and residue storage areas; and, • Treatment equipment storage areas.
Summary of Potential Pollutant Sources	<p>Where information is available, facilities that have used chlorophenolic, creosote, or chromium-copper-arsenic formulations for wood surface protection or wood preserving activities on-site in the past shall identify in the inventory the following:</p> <ul style="list-style-type: none"> • Areas where contaminated soils, treatment equipment, and stored materials still remain; and, • The management practices employed to <i>minimize</i> the contact of these materials with <i>stormwater</i> runoff.
Additional Non-Numeric Effluent Limits	
<p>The description of <i>stormwater</i> management controls shall address the following areas of the site: log, lumber and other wood product storage areas; residue storage areas; loading and unloading areas; material handling areas; chemical storage areas; and equipment/vehicle maintenance, storage and repair areas.</p> <p>Facilities that surface protect and/or preserve wood products shall address specific BMPs for wood surface protection and preserving activities. The SWPPP shall address the following minimum components:</p>	
Discharges to Copper Impaired Waters	<p>If the facility discharges to a Copper <i>Impaired waterbody</i>, the owner or operator shall prevent the exposure of copper sources and copper containing materials or processes to <i>stormwater</i>. These materials shall be protected by a storm-resistant shelter to prevent exposure to rain, snow, snowmelt, and/or runoff.</p>

<p style="text-align: center;">Good Housekeeping Measures</p>	<p>Good housekeeping measures in storage areas, loading and unloading areas, and material handling areas shall be designed to:</p> <p>(a) Limit the <i>discharge</i> of wood debris;</p> <p>(b) <i>Minimize</i> the leachate generated from decaying wood materials;</p> <p>(c) <i>Minimize</i> the generation of dust; and</p>										
<p style="text-align: center;">Erosion and Sediment Control Plan</p>	<p>The <i>Stormwater</i> Pollution Prevention Plan (SWPPP) shall include details of temporary and permanent structural and vegetative measures that will be used to control erosion and sedimentation from areas at the facility, including but not limited to log storage areas, haul roads and areas where vehicles are maintained.</p> <p>The design, installation, inspection, maintenance and repair of erosion and sediment controls shall conform to the New York Standards and Specifications for Erosion and Sediment Control, 2016, or equivalent</p>										
<p style="text-align: center;">Inspections</p>	<p>Inspections at processing areas, transport areas, and treated wood storage areas of facilities performing wood surface protection and preservation activities shall be performed monthly to assess the usefulness of practices in minimizing the deposit of treatment chemicals on unprotected soils and in areas that will come in contact with <i>stormwater discharges</i>.</p>										
<p style="text-align: center;">Numeric Effluent Limitations</p>	<p>The following limitations shall be met by existing and new facilities:</p> <p><u>Wet deck storage area runoff</u> - <i>Non-stormwater discharges</i> from areas used for the storage of logs where water, without chemical additives, is intentionally sprayed or deposited on logs to deter decay or infestation by insects are required to meet the following effluent limitations:</p> <table border="1" style="width: 100%; border-collapse: collapse;"> <tr> <th colspan="2" style="text-align: center;">Table VII-A-1 Sector A – Numeric Effluent Limitations</th> </tr> <tr> <td colspan="2">Wet Decking <i>Discharges</i> at Log Storage and Handling Areas (SIC 2411) Subject to the <i>Point Source</i> Category Provisions of 40CFR Part 429 Subpart I.</td> </tr> <tr> <th style="width: 30%; text-align: center;">Parameter</th> <th style="text-align: center;">Effluent Limitations</th> </tr> <tr> <td>pH</td> <td style="text-align: center;">6.0 – 9.0 s.u.</td> </tr> <tr> <td>Debris (woody material such as bark, twigs, branches, heartwood, or sapwood)</td> <td>No <i>discharge</i> of debris that will not pass through a 2.54 cm (1") diameter round opening.</td> </tr> </table>	Table VII-A-1 Sector A – Numeric Effluent Limitations		Wet Decking <i>Discharges</i> at Log Storage and Handling Areas (SIC 2411) Subject to the <i>Point Source</i> Category Provisions of 40CFR Part 429 Subpart I.		Parameter	Effluent Limitations	pH	6.0 – 9.0 s.u.	Debris (woody material such as bark, twigs, branches, heartwood, or sapwood)	No <i>discharge</i> of debris that will not pass through a 2.54 cm (1") diameter round opening.
Table VII-A-1 Sector A – Numeric Effluent Limitations											
Wet Decking <i>Discharges</i> at Log Storage and Handling Areas (SIC 2411) Subject to the <i>Point Source</i> Category Provisions of 40CFR Part 429 Subpart I.											
Parameter	Effluent Limitations										
pH	6.0 – 9.0 s.u.										
Debris (woody material such as bark, twigs, branches, heartwood, or sapwood)	No <i>discharge</i> of debris that will not pass through a 2.54 cm (1") diameter round opening.										

Benchmarks	Timber product facilities are required to monitor their <i>stormwater discharges</i> for the <i>pollutants</i> of concern listed in the appropriate section of Table VII-A-2.	
	Table VII-A-2 Sector A – Benchmark Monitoring Requirements	
	Pollutants of Concern	Benchmark Monitoring Cutoff Concentration
	General Sawmills and Planning Mills (SIC 2421)	
	Chemical Oxygen Demand (COD)	120 mg/L
	Total Suspended Solids (TSS)	100 mg/L
	Total Nitrogen (TN) *	6 mg/L
	Total Recoverable Zinc	110 ug/L
	Wood Preserving Facilities (SIC 2491)	
	Total Recoverable Arsenic	150 ug/L
	Total Recoverable Chromium	1.8 mg/L
	Total Recoverable Copper	12 ug/L
	Log Storage and Handling Facilities (SIC 2411)	
	Total Suspended Solids (TSS)	100 mg/L
	Hardwood Dimension and Flooring Mills; Special Products Sawmills, not elsewhere classified; Millwork, Veneer, Plywood and Structural Wood; Wood Containers; Wood Buildings and Mobile Homes; Reconstituted Wood Products; and Wood Products Facilities not elsewhere classified (SIC Codes 2426, 2429, 2431-2439 (except 2434), 2448, 2449, 2451, 2452, 2493, and 2499).	
	Chemical Oxygen Demand (COD)	120 mg/L
	Total Suspended Solids (TSS)	100 mg/L
* Total Nitrogen is calculated as the sum of ammonia, nitrate-nitrite and organic nitrogen.		

Sector B – Paper and Allied Products Manufacturing

Applicability	<p>The requirements listed under this section apply to <i>stormwater discharges associated with industrial activity</i> from facilities classified as paper and allied products manufacturing under SIC Major Group 26 that are engaged in the following activities:</p> <ul style="list-style-type: none"> • Manufacture of pulps from wood and other cellulose fibers and from rags; • Manufacture of paper and paperboard into converted products, such as paper coated off the paper machine, paper bags, paper boxes and envelopes; and, • Manufacture of bags of plastic film and sheet. 										
Numeric Effluent Limitations	No Numeric Effluent Limits specified for this sector.										
Benchmarks	<p>Paperboard mills are required to monitor their <i>stormwater discharges</i> for the <i>pollutants</i> of concern listed in Table VII-B-1.</p> <table border="1" style="width: 100%; border-collapse: collapse;"> <thead> <tr> <th colspan="2" style="text-align: center;">Table VII-B-1.</th> </tr> <tr> <th colspan="2" style="text-align: center;">Sector B - Benchmark Monitoring Requirements</th> </tr> <tr> <th style="text-align: left;"><i>Pollutants</i> of Concern</th> <th style="text-align: left;"><i>Benchmark Monitoring</i> Cutoff Concentration</th> </tr> </thead> <tbody> <tr> <td colspan="2">Paperboard Mills (SIC 2631)</td> </tr> <tr> <td>Chemical Oxygen Demand (COD)</td> <td style="text-align: center;">120 mg/L</td> </tr> </tbody> </table>	Table VII-B-1.		Sector B - Benchmark Monitoring Requirements		<i>Pollutants</i> of Concern	<i>Benchmark Monitoring</i> Cutoff Concentration	Paperboard Mills (SIC 2631)		Chemical Oxygen Demand (COD)	120 mg/L
Table VII-B-1.											
Sector B - Benchmark Monitoring Requirements											
<i>Pollutants</i> of Concern	<i>Benchmark Monitoring</i> Cutoff Concentration										
Paperboard Mills (SIC 2631)											
Chemical Oxygen Demand (COD)	120 mg/L										

Sector C – Chemical and Allied Products Manufacturing

Applicability	<p>The requirements listed under this section apply to <i>stormwater discharges associated with industrial activity</i> from facilities engaged in manufacturing the following products and generally described by the SIC code shown:</p> <ul style="list-style-type: none">a. Basic industrial inorganic chemicals (including SIC Code 281);b. Plastic materials and synthetic resins, synthetic rubbers, and cellulosic and other manmade fibers, except glass (including SIC Code 282);c. Medicinal chemicals and pharmaceutical products, including the grading, grinding and milling of botanicals (including SIC Code 283);d. Soap and other detergents, including facilities producing glycerin from vegetable and animal fats and oils; specialty cleaning, polishing, and sanitation preparations; surface active preparations used as emulsifiers, wetting agents, and finishing agents, including sulfonated oils; and perfumes, cosmetics, and other toilet preparations (including SIC Code 284);e. Paints (in paste and ready-mixed form); varnishes; lacquers; enamels and shellac; putties, wood fillers, and sealers; paint and varnish removers; paint brush cleaners; and allied paint products (including SIC Code 285);f. Industrial organic chemicals (including SIC Code 286);g. Nitrogen and phosphorous based fertilizers, mixed fertilizer, pesticides, and other agricultural chemicals (including SIC Code 287);h. Industrial and household adhesives, glues, caulking compounds, sealants, and linoleum, tile, and rubber cements from vegetable, animal, or synthetic plastics materials; explosives; printing ink, including gravure ink, screen process and lithographic inks ; miscellaneous chemical preparations, such as fatty acids, essential oils, gelatin (except vegetable), sizes, bluing, laundry sours, and writing and stamp pad ink; industrial compounds, such as boiler and heat insulating compounds; and chemical supplies for foundries (including SIC Code 289); andi. Ink and paints, including china painting enamels, India ink, drawing ink, platinum paints for burnt wood or leather work, paints for china painting, artists' paints and artists' water colors (SIC Code 3952, limited to those listed; for others in SIC Code 3952 not listed above, see Sector Y).j. Petroleum refineries listed under SIC Code 2911. Contaminated <i>stormwater discharges</i> from petroleum refining or drilling operations that are subject to nationally established BAT or <i>BPT</i> guidelines found at 40 CFR Part 419 are not authorized by this permit.
----------------------	---

Prohibitions	<p><u>Prohibition of non-stormwater discharges</u> - In addition to the general prohibition of non-stormwater discharges in Part I.C.1, the following discharges not covered by this permit include, but are not limited to:</p> <ul style="list-style-type: none"> • Inks, paints, or substances (hazardous, nonhazardous, etc.) resulting from an on-site spill, including materials collected in drip pans; • Washwaters from material handling and processing areas; or • Washwaters from drum, tank, or container rinsing and cleaning.
SWPPP Requirements in Addition to Part III	
Site Map	<p>The site map shall identify where any of the following may be exposed to precipitation/surface runoff:</p> <ul style="list-style-type: none"> • Processing and storage areas; • Access roads, rail cars and tracks; • Areas where substances are transferred in bulk; and, • Operating machinery
Summary of Potential Pollutant Sources	<p>A description of the following sources and activities that have potential <i>pollutants</i> associated with them:</p> <ul style="list-style-type: none"> • Loading, unloading and transfer of chemicals; • Outdoor storage of salt, pallets, coal, drums, containers, fuels, fueling stations; • Vehicle and equipment maintenance/cleaning areas; • Areas where the treatment, storage or disposal (on-site or off-site) of waste/wastewater occur; • Storage tanks and other containers; • Processing and storage areas; • Access roads, rail cars and tracks; • Areas where the transfer of substances in bulk occurs; and, • Areas where machinery operates.

Additional Non-Numeric Effluent Limits		
Good Housekeeping Measures	At a minimum, the SWPPP shall include:	
	<p>(a) A schedule for regular pickup and disposal of garbage and waste materials, or adopt other appropriate measures to reduce the potential for the <i>discharge</i> of <i>stormwater</i> that has come into contact with garbage or waste materials; and</p> <p>(b) Routine inspections of the condition of drums, tanks and containers for potential leaks</p>	
Numeric Effluent Limitations	The following <i>effluent limitations</i> shall be met by existing and new <i>discharges</i> with phosphate fertilizer manufacturing runoff. The provisions of this paragraph are applicable to <i>stormwater discharges</i> from the phosphate subcategory of the fertilizer manufacturing <i>point source</i> category (40 CFR 418.10, Subpart A). The term contaminated <i>stormwater</i> runoff shall mean precipitation runoff, that during manufacturing or processing, comes into contact with any raw materials, intermediate product, finished product, by-products or waste product.	
	The concentration of <i>pollutants</i> in <i>stormwater discharges</i> shall not exceed the <i>effluent limitations</i> in Table VII-C-1.	
	Table VII-C-1. Sector C - Numeric Effluent Limitation	
	Parameter	Effluent Limitations
		<i>Daily Maximum</i> <i>30-day Average</i>
	Phosphate Subcategory of the Fertilizer Manufacturing Point Source Category (40 CFR 418.10) - applies to precipitation runoff that, during manufacturing or processing, comes into contact with any raw materials, intermediate product, finished product, by-products or waste product (SIC 2874)	
	Total Phosphorus (as P)	105 mg/L 35 mg/L
	Fluoride	75 mg/L 25 mg/L
Benchmarks	Agricultural chemical manufacturing facilities; industrial inorganic chemical facilities; soaps, detergents, cosmetics, and perfume manufacturing facilities; and plastics, synthetics, and resin manufacturing facilities are required to monitor their <i>stormwater discharges</i> for the <i>pollutants</i> of concern listed in Table VII-C-2 below.	
	Table VII-C-2 Sector C - Benchmark Monitoring Requirement	
	Pollutants of Concern	Benchmark Monitoring Cutoff Concentration

	Agricultural Chemicals (SIC 2873-2879)	
	Total Nitrogen (TN)	6 mg/L
	Total Recoverable Iron	1 mg/L
	Total Recoverable Lead	69 ug/L
	Total Recoverable Zinc	110 ug/L
	Total Phosphorus	2 mg/L
	Industrial Inorganic Chemicals (SIC 2812-2819)	
	Total Recoverable Aluminum	750 ug/L
	Total Recoverable Iron	1 mg/L
Benchmarks (Continued)	Table VII-C-2 (Continued) Sector C - Benchmark Monitoring Requirement	
	<i>Pollutants of Concern</i>	<i>Benchmark Monitoring Cutoff Concentration</i>
	Industrial Inorganic Chemicals (SIC 2812-2819) (Continued)	
	Total Nitrogen (TN)	6 mg/L
	Soaps, Detergents, Cosmetics, and Perfumes (SIC 2841-2844)	
	Total Nitrogen (TN)	6 mg/L
	Total Recoverable Zinc	110 ug/L
	Plastics, Synthetics, and Resins (SIC 2821-2824)	
	Total Recoverable Zinc	110 ug/L
	Petroleum Refineries (SIC 2911)	
	Oil and Grease	100 mg/L
	Benzene	50 ug/L
	Ethylbenzene	50 ug/L
	Toluene	50 ug/L
	Xylene	50 ug/L
	Total Recoverable Lead	69 ug/L
	Total Recoverable Zinc	110 ug/L
	* Total Nitrogen is calculated as the sum of ammonia, nitrate-nitrite and organic nitrogen.	

Sector D – Asphalt Paving & Roofing Materials & Lubricant Manufacturers

Applicability	<p>The requirements listed under this section apply to <i>stormwater discharges associated with industrial activity</i> from facilities engaged in the following activities: manufacturing asphalt paving and roofing materials, including those facilities commonly identified by SIC Codes 2951 and 2952; portable asphalt plants (also commonly identified by SIC Code 2951); and manufacturing miscellaneous products of petroleum and coal, including those facilities classified as SIC Code 2992 and 2999. This section applies to mobile asphalt plants.</p>
Limitations on Coverage	<p>The following <i>stormwater discharges associated with industrial activity</i> are not authorized by this section of the permit:</p> <ol style="list-style-type: none"> a. <i>Stormwater discharges</i> from petroleum refining facilities, including those that manufacture asphalt or asphalt products that are classified as SIC Code 2911; b. <i>Stormwater discharges</i> from oil recycling facilities; and c. <i>Stormwater discharges</i> associated with fats and oils rendering. d. <i>Stormwater discharges</i> mixed with asphalt release agents.
Prohibitions	<p>In addition to the general prohibitions of non-<i>stormwater discharges</i> in Part I.C.1, the following <i>discharges</i> are not covered by this permit include but are not limited to:</p> <ul style="list-style-type: none"> • Contact & Noncontact cooling water • Floor and equipment wash water • Wastewater from vehicle and internal vehicle wash-out • Cooling tower and boiler blow downs • Vehicle and equipment maintenance fluids. <p>These <i>discharges</i> must be covered under a separate <i>SPDES</i> permit</p>
SWPPP Requirements in Addition to Part III	
Site Map	<p>Identify where asphalt release agents are stored, used, recycled and disposed</p>

Additional Non-Numeric Effluent Limits	
Inspections	<p>The SWPPP shall provide for monthly routine facility inspections as part of the maintenance program at:</p> <ul style="list-style-type: none"> • Material storage and handling areas; • Liquid storage tanks, hoppers or silos; • Vehicle and equipment maintenance, cleaning, and fueling areas; • Material handling vehicles; • Spray racks; and, • Equipment and processing areas
Non Structural BMPs	<p>The SWPPP shall include:</p> <ul style="list-style-type: none"> • Procedures to <i>minimize</i> the exposure of raw and waste materials to surface runoff and precipitation. If possible, store the equivalent one day's volume of materials indoors • Procedures to <i>minimize</i> the potential of any outdoor storage of fluids/drums/totes from coming in contact with precipitation/runoff. Fluid containers with valves must be maintained in a closed and locked position • A schedule of regular inspections of equipment for leaks, spills, malfunctioning, worn or corroded parts or equipment; • A preventive maintenance program for manufacturing equipment; • Provisions for drip pans or equivalent measures to be placed under any leaking piece of stationary equipment until the leak is repaired. The drip pans shall be inspected for leaks and potential overflow and all liquids properly disposed of in accordance with local, <i>State</i>, and federal requirements.

Structural BMPs	<p>The SWPPP shall document considerations of the following <i>BMPs</i> (or their equivalents):</p> <ul style="list-style-type: none"> • Provide an impermeable pad under asphalt spray and vehicle wash racks, with sump to collected excess runoff • Containment or diversion structures such as dikes, berms, culverts, trenches, elevated concrete pads, and grading installed where appropriate to <i>minimize</i> contact of <i>stormwater</i> runoff with outdoor processing equipment or stored materials; • Diversion of runoff away from manufacturing areas, storage areas and asphalt spray racks via dikes, berms, containment trenches, culverts and surface grading; • Installation of a sump/pump with each containment pit, and <i>discharge</i> collected fluids to a sanitary sewer system or collect for proper disposal 																					
Numeric Effluent Limitations	<table border="1" style="width: 100%; border-collapse: collapse;"> <thead> <tr> <th colspan="3" style="text-align: center;">Table VII-D-1 Sector D - Numeric Effluent Limitation</th> </tr> <tr> <th style="width: 35%; text-align: center;">Parameter</th> <th colspan="2" style="text-align: center;">Effluent Limitations</th> </tr> <tr> <td></td> <th style="text-align: center;"><i>Daily Maximum</i></th> <th style="text-align: center;"><i>30-day Average</i></th> </tr> </thead> <tbody> <tr> <td colspan="3"><i>Discharges from areas where production of asphalt paving and roofing emulsions occurs (SIC 2951, 2952) Subject to the Point Source Category Provisions of 40 CFR Part 443 Subpart A.</i></td> </tr> <tr> <td>Total Suspended Solids (TSS)</td> <td style="text-align: center;">23 mg/L</td> <td style="text-align: center;">15 mg/L</td> </tr> <tr> <td>Oil & Grease</td> <td style="text-align: center;">15 mg/L</td> <td style="text-align: center;">10 mg/L</td> </tr> <tr> <td>pH</td> <td colspan="2" style="text-align: center;">6.0 to 9.0 SU</td> </tr> </tbody> </table>	Table VII-D-1 Sector D - Numeric Effluent Limitation			Parameter	Effluent Limitations			<i>Daily Maximum</i>	<i>30-day Average</i>	<i>Discharges from areas where production of asphalt paving and roofing emulsions occurs (SIC 2951, 2952) Subject to the Point Source Category Provisions of 40 CFR Part 443 Subpart A.</i>			Total Suspended Solids (TSS)	23 mg/L	15 mg/L	Oil & Grease	15 mg/L	10 mg/L	pH	6.0 to 9.0 SU	
Table VII-D-1 Sector D - Numeric Effluent Limitation																						
Parameter	Effluent Limitations																					
	<i>Daily Maximum</i>	<i>30-day Average</i>																				
<i>Discharges from areas where production of asphalt paving and roofing emulsions occurs (SIC 2951, 2952) Subject to the Point Source Category Provisions of 40 CFR Part 443 Subpart A.</i>																						
Total Suspended Solids (TSS)	23 mg/L	15 mg/L																				
Oil & Grease	15 mg/L	10 mg/L																				
pH	6.0 to 9.0 SU																					
Benchmarks	<p>Asphalt paving and roofing materials manufacturing facilities are required to monitor their <i>stormwater discharges</i> for the <i>pollutant</i> of concern listed in Table VII-D-2.</p> <table border="1" style="width: 100%; border-collapse: collapse;"> <thead> <tr> <th colspan="2" style="text-align: center;">Table VII-D-2 Sector D - Benchmark Monitoring Requirement</th> </tr> <tr> <th style="width: 40%; text-align: center;"><i>Pollutants of Concern</i></th> <th style="text-align: center;"><i>Benchmark Monitoring Cut-off Concentration</i></th> </tr> </thead> <tbody> <tr> <td colspan="2">Asphalt Paving and Roofing Materials (SIC 2951, 2952)</td> </tr> <tr> <td>Total Suspended Solids (TSS)</td> <td style="text-align: center;">100 mg/L</td> </tr> </tbody> </table>	Table VII-D-2 Sector D - Benchmark Monitoring Requirement		<i>Pollutants of Concern</i>	<i>Benchmark Monitoring Cut-off Concentration</i>	Asphalt Paving and Roofing Materials (SIC 2951, 2952)		Total Suspended Solids (TSS)	100 mg/L													
Table VII-D-2 Sector D - Benchmark Monitoring Requirement																						
<i>Pollutants of Concern</i>	<i>Benchmark Monitoring Cut-off Concentration</i>																					
Asphalt Paving and Roofing Materials (SIC 2951, 2952)																						
Total Suspended Solids (TSS)	100 mg/L																					

Sector E – Glass, Clay, Cement, Concrete and Gypsum Products

Applicability	<p>The requirements listed under this section apply to <i>stormwater discharges</i> associated with <i>industrial activity</i> from facilities generally classified under SIC Major Group 32 that are engaged in either manufacturing the following products or performing the following activities:</p> <ul style="list-style-type: none"> • Flat, pressed, or blown glass or glass containers; • Hydraulic cement; • Clay products including tile and brick; • Pottery and porcelain electrical supplies; • Concrete products; • Gypsum products; • Non-clay refractories; • Minerals and earths , ground or otherwise treated; • Lime manufacturing; • Cut stone and stone products; • Asbestos products; and, • Mineral wool and mineral wool insulation products.
Prohibitions Non - Stormwater discharges	<p>Facilities engaged in production of ready-mix concrete, concrete block, brick or similar products shall include in the certification a description of measures that ensure that process wastewater that results from washing of trucks, mixers, transport buckets, forms or other equipment are <i>discharged</i> in accordance with a separate SPDES permit or are recycled.</p>
Additional SWPPP Requirements	
Site Map	<p>The site map shall identify the locations of the following, if applicable:</p> <ul style="list-style-type: none"> • Bag house or other dust control device; • Recycle/sedimentation pond, clarifier or other device used for the treatment of process wastewater and the areas that drain to the treatment device.
Additional Non-Numeric Effluent Limits	
Inspections	<p>The inspection shall take place while the facility is in operation and shall include all of the following areas that are exposed to <i>stormwater</i>:</p> <ul style="list-style-type: none"> • Material handling areas • Aboveground storage tanks • Hoppers or silos, • Dust collection/containment systems • Truck wash down/equipment cleaning areas

Good Housekeeping

Facilities shall prevent or *minimize* the *discharge* of:

- Spilled cement;
- Aggregate (including sand or gravel);
- Kiln dust;
- Fly ash;
- Settled dust; and
- Other *significant materials* in *stormwater* from paved portions of the site that are exposed to *stormwater*.

Measures used to *minimize* the presence of these materials may include regular sweeping, or other equivalent measures.

The SWPPP shall indicate the frequency of sweeping or equivalent measures. The frequency shall be determined based upon consideration of the amount of *industrial activity* occurring in the area and frequency of precipitation, but shall not be less than once per week if cement, aggregate, kiln dust; fly ash, or settled dust are being handled or processed.

Facilities shall prevent the exposure of fine granular solids (such as cement, kiln dust, etc.) to *stormwater*. Where practicable, these materials shall be stored in enclosed silos or hoppers, buildings, or under other covering.

Numeric Effluent Limitations	<p>The following limitations shall be met by existing and new facilities: Cement manufacturing facility, material storage runoff, including hydraulic cement product manufacturers (SIC 3241). Any <i>discharge</i> composed of runoff that derives from the storage of materials including raw materials, intermediate products, finished products, and waste materials that are used in or derived from the manufacture of cement shall not exceed the limitations in Table VII-E-1.</p> <p>Runoff from the storage piles shall not be diluted with other <i>stormwater</i> runoff or flows to meet these limitations.</p> <p>Any untreated overflow from facilities designed, constructed and operated to treat the volume of material storage pile runoff that is associated with a 10-year, 24-hour rainfall event shall not be subject to the TSS or pH limitations.</p> <p>Facilities subject to these numeric <i>effluent limitations</i> must be in compliance with these limits upon commencement of coverage and for the entire term of this permit.</p>		
	Table VII-E-1 Sector E - Numeric Effluent Limitation		
	Parameter	Effluent Limitations	
		Daily Maximum	30-day Average
	Cement Manufacturing Facility, Material Storage Runoff: Any <i>discharge</i> composed of runoff that derives from the storage of materials including raw materials, intermediate products, finished products, and waste materials that are used in or derived from the manufacture of cement. Subject to the <i>Point Source</i> Category Provisions of 40 CFR Part 411 Subpart C.		
	Total Suspended Solids (TSS)	50 mg/L	NA
	pH	6.0 to 9.0 SU	
Benchmarks	<p>Clay product manufacturers (SIC 3245-3259, SIC 3261-3269) and concrete and gypsum product manufacturers (SIC 3271-3275) are required to monitor their <i>stormwater discharges</i> for the <i>pollutants</i> of concern listed in Table VII-E-2.</p>		
	Table VII-E-2 Sector E - Benchmark Monitoring Requirement		
	Pollutants of Concern	Benchmark Monitoring Cut-off Concentration	
	Clay Product Manufacturers (SIC 3245-3259, 3261-3269)		
	Total Recoverable Aluminum	750 ug/L	
	Concrete and Gypsum Product Manufacturers (SIC 3271-3275)		
	Total Suspended Solids (TSS)	100 mg/L	
	pH	6.0 to 9.0 su	
Total Recoverable Iron	1 mg/L		

Sector F – Primary Metals

Applicability	<p>The requirements listed under this section apply to <i>stormwater discharges associated with industrial activity</i> from the following types of facilities in the primary metal industry, and generally described by the SIC code shown:</p> <ul style="list-style-type: none">a. Steel works, blast furnaces, and rolling and finishing mills, including: steel wire drawing and steel nails and spikes; cold-rolled steel sheet, strip, and bars; and steel pipes and tubes (SIC Code 331);b. Iron and steel foundries, including: gray and ductile iron, malleable iron, steel investment, and steel foundries not elsewhere classified (SIC Code 332);c. Primary smelting and refining of nonferrous metals, including: primary smelting and refining of copper, and primary production of aluminum (SIC Code 333);d. Secondary smelting and refining of nonferrous metals (SIC Code 334);e. Rolling, drawing, and extruding of nonferrous metals, including: rolling, drawing, and extruding of copper; rolling, drawing and extruding of nonferrous metals except copper and aluminum; and drawing and insulating of nonferrous wire (SIC Code 335);f. Nonferrous foundries (castings), including: aluminum die-castings, nonferrous die-castings, except aluminum, aluminum foundries, copper foundries, and nonferrous foundries, except copper and aluminum (SIC Code 336); andg. Miscellaneous primary metal products, not elsewhere classified, including: metal heat treating, and primary metal products, not elsewhere classified (SIC Code 339). <p>Activities covered include, but are not limited to, <i>stormwater discharges</i> associated with coking operations, sintering plants, blast furnaces, smelting operations, rolling mills, casting operations, heat treating, extruding, drawing, or forging of all types of ferrous and nonferrous metals, scrap, and ore.</p>
----------------------	---

SWPPP Requirements in Addition to Part III	
Site Map	<p>The site map shall identify where any of the following activities may be exposed to precipitation/surface runoff:</p> <ul style="list-style-type: none"> • Storage or disposal of wastes such as spent solvents/baths, sand, slag/dross; • Liquid storage tanks/drums; • Processing areas including pollution control equipment (e.g., baghouses); • Storage areas of raw materials such as coal, coke, scrap, sand, fluxes, refractories, or metal in any form. <p>Indicate sources where an accumulation of significant amounts of particulate matter could occur from such sources as:</p> <ul style="list-style-type: none"> • Furnace or oven emissions <p>Losses from coal/coke handling operations, etc. which could result in a <i>discharge of pollutants</i> to surface waters</p>
Summary of Potential Pollutant Sources	<p>The inventory of materials handled at the site that potentially may be exposed to precipitation/runoff shall include areas where deposition of particulate matter from process air emissions or losses during material handling activities are possible.</p>
Additional Non-Numeric Effluent Limits	
Inspections	<p>Inspections shall be conducted at least quarterly, and shall address all potential sources of <i>pollutants</i>, including (if applicable):</p> <ul style="list-style-type: none"> • Air pollution control equipment (e.g., baghouses, electrostatic precipitators, scrubbers, and cyclones) shall be inspected for any signs of degradation (e.g., leaks, corrosion, or improper operation) that could limit their efficiency and lead to excessive emissions. The <i>owner or operator</i> shall consider monitoring air flow at inlets/outlets, or equivalent measures, to check for leaks (e.g., particulate deposition) or blockage in ducts; • All process or material handling equipment (e.g., conveyors, cranes, and vehicles) shall be inspected for leaks, drips, or the potential loss of materials; and • Material storage areas (e.g., piles, bins or hoppers for storing coke, coal, scrap, or slag, as well as chemicals stored in tanks/drums) shall be examined for signs of material losses due to wind or <i>stormwater</i> runoff.
Discharges to Copper Impaired Waters	<p>If the facility discharges to a Copper Impaired waterbody, the owner or operator shall prevent the exposure of copper sources and copper containing materials or processes to <i>stormwater</i>. These materials shall be protected by a storm-resistant shelter to prevent exposure to rain, snow, snowmelt, and/or runoff.</p>

<p style="text-align: center;">Good Housekeeping</p>	<p>The SWPPP shall document considerations of the following <i>BMPs</i> (or their equivalents):</p> <ul style="list-style-type: none"> (a) Establishment of a cleaning/maintenance program for all impervious areas of the facility where particulate matter, dust, or debris may accumulate, especially areas where material loading/unloading, storage, handling, and processing occur. (b) Paving of areas where vehicle traffic or material storage occurs, but where vegetative or other stabilization methods are not practicable. Sweeping programs shall be instituted in these areas as well. (c) Use of stormwater management devices such as sediment traps, vegetative buffer strips, filter fabric fence, sediment filtering boom, gravel outlet protection, or other equivalent measures, that effectively trap or remove sediment for unstabilized areas of the facility where sweeping is not practical.
<p style="text-align: center;">BMPs Outside Storage Areas</p>	<p><i>BMPs</i> for outside material storage such as foundry returns, scrap metal, turnings, fines, ingots, bars, pigs, wire, where practicable:</p> <ul style="list-style-type: none"> • Confine storage to designated and labeled areas outside of drainage pathways and away from surface waters. • Provide temporary cover (e.g., tarps) for the storage area. • <i>Minimize</i> material storage through effective inventory and shipping controls. • <i>Minimize</i> run-on from adjacent properties with diversion dikes, berms, curbing, surface grading or other equivalent measures. • Stabilize areas with exposed soil with diversion dikes, berms, curbing, concrete pads, etc.
<p style="text-align: center;">Numeric Limits</p>	<p>No Numeric Effluent Limits specified for this sector.</p>
<p style="text-align: center;">Benchmarks</p>	<p>Primary metals facilities are required to monitor their <i>stormwater discharges</i> for the <i>pollutants</i> of concern listed in Table VII-F-1 below.</p>

Table VII-F-2	
Sector F - Benchmark Monitoring Requirement	
Pollutants of Concern	Benchmark Monitoring Cut-off Concentration
Steel Works, Blast Furnaces, and Rolling and Finishing Mills (SIC 3312-3317)	
Total Recoverable Aluminum	750 ug/L
Total Recoverable Zinc	110 ug/L
Iron and Steel Foundries (SIC 3321-3325)	
Total Recoverable Aluminum	750 ug/L
Total Suspended Solids (TSS)	100 mg/L
Total Recoverable Copper	12 ug/L
Total Recoverable Iron	1 mg/L
Total Recoverable Zinc	110 ug/L
Rolling, Drawing, and Extruding of Nonferrous Metals (SIC 3351-3357)	
Total Recoverable Copper	12 ug/L
Total Recoverable Zinc	110 ug/L
Nonferrous Foundries (SIC 3363-3369)	
Total Recoverable Copper	12 ug/L
Total Recoverable Zinc	110 ug/L

Sector G – Metal Mining (Ore Mining & Dressing)

Applicability	<p>The requirements listed under this section apply to <i>stormwater discharges associated with industrial activity</i> from active, temporarily inactive and inactive metal mining and ore dressing facilities including mines abandoned on federal lands, as classified under SIC Major Group 10. Coverage is required for facilities that <i>discharge stormwater</i> that has come into contact with, or is contaminated by, any overburden, raw material, intermediate product, finished product, byproduct, or waste product located on the site of the operation. SIC Major Group 10 includes establishments primarily engaged in mining of ores, developing mines, or exploring for metallic minerals (ores) and also includes ore dressing and beneficiating operations, whether performed at <i>co-located</i>, dedicated mills or at separate mills, such as custom mills. For the purposes of this section, the term "metal mining" includes any of the separate activities listed above. Covered <i>discharges</i> include:</p> <p style="margin-left: 40px;">a. All <i>stormwater discharges</i> from inactive metal mining facilities; and</p> <p style="margin-left: 40px;">b. <i>Stormwater discharges</i> from the following areas of active and temporarily inactive metal mining facilities:</p> <ul style="list-style-type: none"> • waste rock/overburden piles if composed entirely of <i>stormwater</i> and not combining with mine drainage; • topsoil piles; • off-site haul/access roads; • on-site haul/access roads constructed of waste rock/overburden if composed entirely of <i>stormwater</i> and not combining with mine drainage; • on-site haul/access roads not constructed of waste rock/overburden/spent ore except if mine drainage is used for dust control; • runoff from tailings dams/dikes when not constructed of waste rock/tailings and no process fluids are present; • runoff from tailings dams/dikes when constructed of waste rock/tailings and no process fluids are present if composed entirely of <i>stormwater</i> and not combining with mine drainage; • concentration building if no contact with material piles; • mill site if no contact with material piles; office/administrative building and housing if mixed with <i>stormwater</i> from industrial area; • chemical storage area; • docking facility if no excessive contact with waste product that would otherwise constitute mine drainage; • explosive storage; • fuel storage; • vehicle/equipment maintenance area/building; • parking areas (if necessary); • power plant; • truck wash areas if no excessive contact with waste product that would otherwise constitute mine drainage; • unreclaimed, disturbed areas outside of active mining area; • reclaimed areas released from reclamation bonds prior to December 17, 1990; and, partially/inadequately reclaimed areas or areas not released from reclamation bonds
----------------------	---

<p style="text-align: center;">Limitations on Coverage</p>	<p><i>Stormwater discharges</i> from active metal mining facilities that are subject to the <i>effluent limitation guidelines</i> for the Ore Mining and Dressing <i>Point Source</i> Category (40 CFR Part 440) are not authorized by this permit.</p> <p>Note: <i>Discharges</i> that come in contact with overburden/waste rock are subject to 40 CFR Part 440, providing: the <i>discharges</i> drain to a <i>point source</i> (either naturally or as a result of intentional diversion), and they combine with mine drainage that is otherwise regulated under 40 CFR Part 440.</p> <p><i>Discharges</i> from overburden/waste rock can be covered under this permit if they are composed entirely of <i>stormwater</i> and do not combine with sources of mine drainage that are subject to 40 CFR Part 440 and meet other eligibility criteria in Paragraph I.C.2</p>
<p style="text-align: center;">Prohibitions</p>	<p>In addition to the general prohibition of non-<i>stormwater discharges</i> in Part I.C.1, the following <i>discharges</i> not covered by this permit include, but are not limited to: adit drainage or contaminated springs or seeps</p>
<p style="text-align: center;">Non-Stormwater discharges</p>	<p><u>Certification of discharge testing</u> - The <i>owner or operator</i> must test or evaluate for the presence of specific mining-related, non-<i>stormwater discharges</i> such as seeps or adit <i>discharges</i> or <i>discharges</i> subject to <i>effluent limitations guidelines</i>, such as mine drainage or process water. Alternatively (if applicable), the <i>owner or operator</i> may certify in the SWPPP that a particular <i>discharge</i> comprised of commingled <i>stormwater</i> and non-<i>stormwater</i> is covered under a separate <i>SPDES</i> permit; and that permit subjects the non-<i>stormwater</i> portion to <i>effluent limitations</i> prior to any commingling. This certification shall identify the non-<i>stormwater discharges</i>, the applicable <i>SPDES</i> permit(s), the <i>effluent limitations</i> placed on the non-<i>stormwater discharge</i> by the permit(s), and the points at which the limitations are applied</p>

Definitions

The following definitions are only for this section of the general permit:

- "*Active metal mining facility*" means a place where work or other activity related to the extraction, removal, or recovery of metal ore is being conducted. For surface mines, this definition does not include any land where grading has returned the earth to a desired contour and reclamation has begun.
- "*Active phase*" means activities including each step from extraction through production of a salable product.
- "*Exploration and construction phase*" entails exploration and land disturbance activities to determine the financial viability of a site. Construction includes the building of site access roads, buildings and removal of overburden and waste rock to expose mineable minerals.
- "*Final Stabilization*" means that all soil-disturbing activities at the site have been completed and a uniform, perennial vegetative cover with a density of eighty (80) percent has been established or equivalent stabilization measures (such as the use of permanent landscape mulches, riprap, or washed/crushed stone) have been employed on all unpaved areas and areas not covered by permanent structures.
- "*Inactive metal mining facility*" means a site or portion of a site where metal mining and/or milling occurred in the past but is not an active facility as defined above, and where the inactive portion is not covered by an active mining permit issued by the applicable (federal or *State*) governmental agency.
- "*Mining operation*" typically consists of three phases, any one of which individually qualifies as a "mining activity." The phases are the exploration and construction phase, the active phase, and the reclamation phase.
"*Reclamation phase*" means activities undertaken, in compliance with applicable mined land reclamation requirements, following the cessation of the *Active Phase*, intended to return the land to an appropriate post-mining land use in order to meet applicable Federal and *State* reclamation requirements.
- "*Temporarily inactive metal mining facility*" means a site or portion of a site where metal mining and/or milling occurred in the past but currently are not being actively undertaken, and the facility is covered by an active mining permit issued by the applicable (federal or *State*) government agency

<p style="text-align: center;">Erosion & Sediment Control Plan</p>	<p>A comprehensive <i>Construction Stormwater</i> Pollution Prevention Plan (Construction SWPPP) addressing the storm water run-on and run-off control systems needed during the mines construction, operation and reclamation phases must be prepared prior to the <i>commencement of any construction activity</i> that will result in a land disturbance of one or more acres of land. The plan must be prepared in accordance to the New York Standards and Specifications for Erosion and Sediment Control, 2016, and the New York State <i>Stormwater</i> Management Design Manual, 2015 or equivalent.</p> <p><i>Stormwater discharges</i> from earth-disturbing activities conducted during the <i>Exploration and Construction Phase</i> prior to active mining activities are covered under this permit. For such earth-disturbing activities, you must comply with all applicable requirements in Parts I - VII of the MSGP except for the technology-based effluent limits in Part VII.G and Part II.A, the inspection and monitoring requirements in Part VII.G and Part IV.</p> <p>Once the <i>Exploration and Construction phase</i> are completed you must comply with “all applicable parts of the permit”</p>
<p>SWPPP Requirements in Addition to Part III</p>	
<p style="text-align: center;">General Site Description for Active & Temporarily Inactive Mines</p>	<p>A description of the mining and associated activities taking place at the site that can potentially affect <i>stormwater discharges</i> covered by this permit. The description shall include:</p> <ul style="list-style-type: none"> • Total acreage within the mine site; • Estimate of the number of acres of disturbed land; • Estimate of the total amount of land proposed to be disturbed throughout the life of the mine; and, <p>General description of the location of the site relative to major transportation routes and communities.</p>
<p style="text-align: center;">General Site Description for Inactive Mines</p>	<p>The SWPPP shall briefly describe the mining and associated activities that took place at the site that can potentially affect the <i>stormwater discharges</i> covered by this permit. The following must be included:</p> <ul style="list-style-type: none"> • Approximate dates of operation; • Total acreage within the mine and/or processing site; • Estimate of acres of disturbed earth; • Activities currently occurring on-site (e.g., reclamation); • General description of site location with respect to transportation routes and communities

<p style="text-align: center;">Site Map All Facilities</p>	<p>The site map shall identify the locations of the following, as appropriate:</p> <ul style="list-style-type: none"> • mining/milling site boundaries; • access and haul roads; • an outline of the drainage areas of each <i>stormwater outfall</i> within the facility, and an indication of the types of <i>discharges</i> from the drainage areas; • equipment storage, fueling and maintenance areas; • materials handling areas; • outdoor manufacturing, storage or material disposal areas; storage areas for chemicals and explosives; • areas used for storage of overburden, materials, soils or wastes; • location of mine drainage (where water leaves mine) or any other process water; • tailings piles/ponds, both proposed and existing; • heap leach pads; • points of <i>discharge</i> from the property for mine drainage/process water; • surface waters; and • boundary of tributary areas that are subject to <i>effluent limitations</i> guidelines
<p style="text-align: center;">Summary of Potential Pollutant Sources All Facilities</p>	<p>For each area of the mine/mill site where <i>stormwater discharges</i> associated with industrial activities occur, the types of <i>pollutants</i> likely to be present in significant amounts must be identified (e.g., heavy metals, sediment). The following factors must be considered: the mineralogy of the ore and waste rock (e.g., acid forming); toxicity and quantity of chemicals used, produced or <i>discharged</i>; the likelihood, if any, of contact with <i>stormwater</i>; vegetation of site; history of <i>reportable</i> leaks/spills of toxic or hazardous <i>pollutants</i>. A summary of any existing ore or waste rock/overburden characterization data and test results for potential generation of acid rock shall also be included. If the ore or waste rock/overburden characterization data are updated due to a change in the ore type being mined, the SWPPP shall be updated with the new data</p>
<p>Additional Non-Numeric Effluent Limits</p>	
<p style="text-align: center;">Employee Training</p>	<p>Employee training shall be conducted at least annually at active mining and temporarily inactive sites.</p>

<p style="text-align: center;">Inspections</p>	<ul style="list-style-type: none"> • Inactive Mines: Annual site compliance evaluations may be impractical for inactive mining sites due to remote location/inaccessibility of the site, in which case the <i>owner or operator</i> must conduct the evaluation at least once every three years. The SWPPP must be documented to explain why annual compliance evaluations are not possible. If the evaluations will be conducted more often than every three years, the frequency of evaluations must be specified. • Active mining sites must be inspected at least monthly. Temporarily inactive sites must be inspected at least quarterly unless adverse weather conditions make the site inaccessible
<p style="text-align: center;">Discharges to Copper Impaired Waters</p>	<p>If the facility discharges to a Copper Impaired waterbody, the owner or operator shall prevent the exposure of copper sources and copper containing materials or processes to <i>stormwater</i>. These materials shall be protected by a storm-resistant shelter to prevent exposure to rain, snow, snowmelt, and/or runoff.</p>
<p>Each of the following <i>BMPs</i> shall be considered and documented in the SWPPP. The potential <i>pollutants</i> identified for the type of mining activity (above) shall determine the priority and appropriateness of the <i>BMPs</i> selected. If it is determined that one or more of these <i>BMPs</i> are not appropriate for the facility, the plan must explain why it is not appropriate. If <i>BMPs</i> are implemented or planned but are not listed here (e.g., substituting a less toxic chemical for a more toxic one), descriptions of them must be included in the SWPPP</p>	

BMPs
All Facilities

The measures to consider include:

- **Diversion of flow away from areas susceptible to erosion and potential pollutant sources:** A description of how and where *stormwater* will be diverted away from potential *pollutant* sources to prevent *stormwater* contamination and/or erosion. *BMP* options may include the following: interceptor dikes and swales; diversion dikes, curbs and berms; pipe slope drains; subsurface drains; drainage/*stormwater* conveyance systems (channels or gutters, open top box culverts and waterbars; rolling dips and road sloping; roadway surface water deflector and culverts); or equivalent measures.
- **Methods to control runoff** (such as check dams; rock outlet protection; level spreaders; grass swales; pipe slope drains; earth dikes; gradient terraces) The potential *pollutant* sources for the type of mine (above) must be considered when determining reasonable and appropriate measures for managing runoff
- **Stabilization methods to prevent or minimize contact with pollutants and/or erosion** (such as entrance stabilization; temporary or permanent seeding; Vegetative buffer strips; Protection of trees; Topsoiling; Soil Conditioning; Contouring; Mulching; Geotextiles (matting, netting, or blankets); Riprap; Gabions; Retaining walls; Capping (where capping of a potential *stormwater* pollution source is necessary, the source being capped and materials and procedures used to cap the contaminant source must be identified)
- **Structural methods for controlling sediment** (such as silt fences; gravel or stone filter berms; brush barriers; sediment traps; other controls such as waterway crossings or wind breaks; or other equivalent measures).
- **Treatment** - If treatment of a *stormwater discharge* is necessary to protect water quality, include a description of the type and location of *stormwater* treatment that will be used. *Stormwater* treatments include the following: chemical or physical systems; oil/water separators; artificial wetlands; etc

The design, installation, maintenance and repair of erosion and sediment controls shall conform to the most current version of the New York Standards and Specifications for Erosion and Sediment.

Numeric Effluent Limitations

The following *effluent limitations* shall be met by existing and new *discharges* from active, temporarily inactive and inactive metal mining and ore dressing facilities including mines abandoned on federal lands, as classified under SIC Major Group 10.

**Table VII-G-1
Sector G – Numeric Effluent Limitations**

Parameter	Effluent Limitations	
	<i>Daily Maximum</i>	<i>30-day Average</i>
Total Mercury	50 ng/L*	

*Mercury Analysis shall be by EPA Method 1631

**Table VII-G-2
Additional Monitoring Requirements for Discharges from Waste Rock and Overburden Piles From Active Ore Mining or Dressing Facilities**

Type of Ore Mined	Pollutants of Concern		
	TSS (mg/l)	pH (SU)	Metals, Total Recoverable
Iron Ore	X	X	Iron, Dissolved
Titanium Ore	X	X	Iron, Nickel (H), Zinc (H)
Copper, Lead, Zinc, Gold, Silver and Molybdenum	X	X	Arsenic, Cadmium (H), Copper (H), Lead (H), Mercury, Zinc (H).

(H) indicates that hardness must also be measured when this *pollutant* is measured.

The above monitoring must be compared to *benchmark monitoring cut-off concentrations* in Table VII-G-3

Discharges from waste rock and overburden piles at active ore mining and dressing facilities Active ore mining and dressing facilities with *discharges* from waste rock and overburden piles must perform analytic monitoring for the parameters listed in Table VII-G-3.

Facilities must also monitor for the parameters listed in Table VII-G-2. However, the *Department* may notify the facility that additional monitoring must be performed to accurately characterize the quality and quantity of *pollutants discharged* from the waste rock/overburden piles.

**Table VII-G-3
Sector G - Benchmark Monitoring Requirements**

Benchmarks

<i>Pollutants of Concern</i>	<i>Benchmark Monitoring Cut-off Concentration</i>
<i>Discharges From Waste Rock and Overburden Piles from Active Ore Mining or Dressing Facilities</i> Iron Ores; Copper Ores; Lead and Zinc Ores; Gold and Silver Ores; Ferroalloy Ores Except Vanadium; Miscellaneous Metal Ores (SIC Codes 1011, 1021, 1031, 1041, 1044, 1061, 1081, 1094, 1099)	
Total Suspended Solids (TSS)	100 mg/L
Chemical Oxygen Demand (COD)	120 mg/L
Turbidity (NTUs)	50 NTUs
pH	6.0 – 9.0 SU
Hardness (as CaCO3)	No Benchmark Value
Total Recoverable Antimony	636 ug/L
Total Recoverable Arsenic	150 ug/L
Total Recoverable Beryllium	130 ug/L
Total Recoverable Cadmium	1.8 ug/L

	Total Recoverable Copper	12 ug/L
	Total Recoverable Iron	1.0 mg/L
	Total Recoverable Lead	69 ug/L
	Total Recoverable Manganese	1.0 mg/L
	Total Recoverable Nickel	0.42 mg/L
	Total Recoverable Selenium	5 ug/L
	Total Recoverable Silver	3.0 ug/L
	Total Recoverable Zinc	110 ug/L
	* Total Nitrogen is calculated as the sum of ammonia, nitrate-nitrite and organic nitrogen	

Table VII-G-4
Applicability of the Multi-Sector General Permit to Stormwater Runoff From Active Mining and Dressing Sites, Temporarily Inactive Sites, and Sites Undergoing Reclamation

Discharge/Source of Discharge	Note/Comment
Storage Piles	
Waste rock/overburden Storage Piles	Applicable if composed entirely of <i>stormwater</i> and not combining with mine drainage. See note below
Topsoil Storage Piles	Applicable
Roads constructed of waste rock or spent ore	
Onsite haul roads	Applicable if composed entirely of <i>stormwater</i> and not combining with mine drainage. See note below
Off Site haul and access roads	Applicable
Roads not constructed of waste rock or spent ore	
Onsite haul roads	Applicable except if mine drainage is used for dust control
Off Site haul and access roads	Applicable
Milling & Concentrating	
Runoff from tailings dams and dikes when constructed of waste rock/tailings	Applicable except if process fluids are present and only if composed entirely of <i>stormwater</i> and not combining with mine drainage. See Note below
Runoff from tailings dams/dikes when not constructed of waste rock and tailings	Except if process fluids are present
Concentration building	If <i>stormwater</i> only and no contact with piles
Mill site	If <i>stormwater</i> only and no contact with piles

Ancillary Areas	
Office and administrative building and housing	If mixed with <i>stormwater</i> from the industrial area
Chemical Storage Areas	Applicable
Docking facility	Except if excessive contact with waste product that would otherwise constitute mine drainage
Explosive storage	Applicable
Fuel storage (oil tanks/coal piles)	Applicable
Vehicle and equipment maintenance area/building	Applicable
Parking areas	But coverage unnecessary if only employee and visitor-type parking
Power Plant - Truck wash area	Except when excessive contact with waste product that would otherwise constitute mine drainage

Table VII-G-4 (Continued) Applicability of the Multi-Sector General Permit to Stormwater Runoff From Active Mining and Dressing Sites, Temporarily Inactive Sites, and Sites Undergoing Reclamation	
Discharge/Source of Discharge	Note/Comment
Reclamation-related areas	
Any disturbed area (unreclaimed)	Only if not in active mining area
Reclaimed areas released from reclamation bonds prior to Dec. 17, 1990	Applicable
Partially/inadequately reclaimed areas or areas not released from reclamation bond	Applicable
<p>Note: <i>Stormwater</i> runoff from these sources are subject to the <i>SPDES</i> program for <i>stormwater</i> unless mixed with <i>discharges</i> subject to the 40 CFR Part 440 that are not regulated by another permit prior to mixing. <i>Nonstormwater discharges</i> from these sources are subject to <i>SPDES</i> permitting and may be subject to the <i>effluent limitation guidelines</i> under 40 CFR Part 440. <i>Discharges</i> from overburden/waste rock and overburden/waste rock related areas are not subject to 40 CFR Part 440 unless: (1) it drains naturally (or is intentionally diverted) to a <i>point source</i>; and (2) combines with "mine drainage" that is otherwise regulated under the Part 440 regulations. For such sources, coverage under this permit would be available if the <i>discharge</i> composed entirely of <i>stormwater</i> does not combine with other sources of mine drainage that are not subject to 40 CFR Part 440, as well as meeting other eligibility criteria contained in Section I.C. of the permit. Permit applicants bear the initial responsibility for determining the applicable technology-based standard for such <i>discharges</i>. DEC recommends that permit applicants contact the relevant <i>SPDES</i> permit issuance authority for assistance to determine the nature and scope of the "active mining area" on a mine-by-mine basis, as well as to determine the appropriate permitting mechanism for authorizing such <i>discharges</i>.</p>	

Sector H – (Reserved)

Sector I - Oil & Gas Extraction and Refining

Applicability	<p>The requirements listed under this section apply to <i>stormwater discharges</i> associated with <i>industrial activity</i> from oil and gas extraction listed under SIC Major Group 13 which have had a <i>discharge</i> of a <i>reportable</i> quantity (RQ) of oil or a hazardous substance for which notification is required under 40 CFR 110.6, 40 CFR 117.21 or 40 CFR 302.6. These include oil and gas exploration, production, processing, or treatment operations, or transmission facilities that <i>discharge stormwater</i> contaminated by contact with or that has come into contact with any overburden raw material, intermediate products, finished products, by-products or waste products located on the site of such operations. Industries in SIC Major Group 13 include the extraction and production of crude oil and natural gas; the production of hydrocarbon liquids and natural gas from coal; and associated oilfield service, supply and repair industries.</p>
Prohibitions Non -Stormwater discharges	<p>Contaminated <i>stormwater discharges</i> from petroleum refining or drilling operations that are subject to nationally established BAT or BPT guidelines found at 40 CFR Part 419 and 40 CFR Part 435 respectively are not authorized by this permit..</p> <p>Oil and gas drilling operations utilizing <i>high volume hydraulic fracturing</i> (HVHF) techniques are not eligible for coverage under this permit.</p> <p>In addition to the general prohibition of non-<i>stormwater discharges</i> in Part I.C.1, the following <i>discharges</i> not covered by this permit include, but are not limited to <i>discharges</i> of vehicle and equipment washwater, including tank cleaning operations. Alternatively, washwater <i>discharges</i> must be authorized under a separate SPDES permit, or be <i>discharged</i> to a sanitary sewer in accordance with applicable industrial pretreatment requirements.</p>
Additional SWPPP Requirements	
Site Map	<p>The site map shall identify where any of the following may be exposed to precipitation/surface runoff:</p> <ul style="list-style-type: none"> • <i>Reportable quantity (RQ) releases</i>; • Locations used for the treatment, storage or disposal of wastes; • Processing areas and storage areas; • Chemical mixing areas; • Construction and drilling areas; • All areas subject to the effluent guidelines requirement of "No <i>Discharge</i>" in accordance with 40 CFR 435.32 and the structural controls to achieve compliance with the "No <i>Discharge</i>" requirement

Summary of Potential Pollutant Sources	<p>The plan shall include a description of the potential <i>pollutant</i> sources from the following activities:</p> <ul style="list-style-type: none"> • Chemical, cement, mud or gel mixing activities • Drilling activities • Equipment cleaning and rehabilitation activities. <p>The plan must include information about the RQ release which triggered the permit application requirements, including:</p> <ul style="list-style-type: none"> • Nature of the release (e.g., spill of oil from a drum storage area); • Amount of oil or hazardous substance released; • Amount of substance recovered; • Date of the release; • Cause of the release (e.g., poor handling techniques and lack of containment in the area); • Areas affected by the release, including land and waters; procedure to cleanup release; • Actions or procedures implemented to prevent or improve response to a release; and remaining potential contamination of <i>stormwater</i> from release (taking into account human health risks, the control of drinking water intakes, and the designated uses of the receiving water). 	
Additional Non-Numeric Effluent Limits		
Good Housekeeping	Vehicle & Equipment Storage Areas	<p>The storage of vehicles and equipment awaiting or having completed maintenance must be confined to designated areas (delineated on the site map). The plan must describe <i>BMPs</i> that prevent or <i>minimize</i> contamination of the <i>stormwater</i> runoff from these areas (e.g., drip pans under equipment, indoor storage, use of berms and dikes); or other equivalent <i>BMPs</i>.</p>
	Materials & Chemical Storage Areas	<p>Storage units of all chemicals and materials must be maintained in good condition so as to prevent contamination of <i>stormwater</i>. Hazardous materials must be plainly labeled</p>
	Chemical Mixing Areas	<p>The plan must describe <i>BMPs</i> that prevent or <i>minimize</i> contamination of the <i>stormwater</i> runoff from chemical mixing areas</p>

Erosion & Sediment Controls	Unless covered by the SPDES General Permit for <i>Stormwater Discharges from Construction Activity (GP-0-15-002)</i> , the additional erosion control requirement for well drilling are as follows	
Erosion & Sediment Controls (Continued)	Site Description	Each plan shall provide a description of the following: <ul style="list-style-type: none"> • A description of the nature of the exploration activity • Estimates of the total area of the site and the area of the site that is expected to be disturbed due to the exploration activity • An estimate of the <i>runoff coefficient</i> of the site • A site map indicating drainage patterns and approximate slopes • The name of all receiving water(s).
	Vegetative Controls	<p>The SWPPP shall include a description of vegetative practices designed to preserve existing vegetation where attainable and revegetate open areas as soon as practicable after grade drilling. Such practices may include:</p> <ul style="list-style-type: none"> • Temporary or permanent seeding • Mulching • Sod stabilization • Vegetative buffer strips • Tree protection practices <p>The <i>owner or operator</i> shall initiate appropriate vegetative practices on all disturbed areas within 14 calendar days of the last activity at that disturbed area.</p> <p>The <i>owner or operator</i> shall comply with the New York State Standards and Specifications for Erosion and Sediment Control, 2016, or equivalent.</p>
	Sediment Control Measures	Off-site vehicle tracking of sediments shall be <i>minimized</i>
	Inspections	The SWPPP shall include procedures for inspection of all erosion controls on the site at least once every seven calendar days.

<p style="text-align: center;">Routine Inspections</p>	<p>All equipment and areas addressed in the SWPPP shall be inspected at a minimum of six month intervals.</p> <p>Equipment and vehicles which store, mix (including all on-site and off-site mixing tanks) or transport chemicals/hazardous materials (including those transporting supplies to oil field activities) will be inspected at least quarterly.</p> <p>For temporarily or permanently inactive oil and gas extraction facilities within Major SIC Group 13, which are remotely located and unstaffed, the inspections shall be performed at least annually</p>												
<p style="text-align: center;">Numeric Effluent Limitations</p>	<p>No Numeric Effluent Limits specified for this sector.</p>												
<p style="text-align: center;">Benchmarks</p>	<p>Oil and gas extraction facilities (SIC Major Group 13) and petroleum refineries (SIC 2911) covered under this section are required to monitor their <i>stormwater discharges</i> for the <i>pollutants</i> of concern listed in Table VII-I-1.</p> <table border="1" data-bbox="329 913 1474 1318"> <thead> <tr> <th colspan="2" data-bbox="329 913 1474 1014" style="text-align: center;"> Table VII-I-2 Sector I - Benchmark Monitoring Requirement </th> </tr> <tr> <th data-bbox="329 1014 667 1073" style="text-align: center;"><i>Pollutants of Concern</i></th> <th data-bbox="667 1014 1474 1073" style="text-align: center;"><i>Benchmark Monitoring Cut-off Concentration</i></th> </tr> </thead> <tbody> <tr> <td colspan="2" data-bbox="329 1073 1474 1136" style="text-align: center;">Oil and Gas Extraction (SIC Major Group 13)</td> </tr> <tr> <td data-bbox="329 1136 667 1199">Total Suspended Solids (TSS)</td> <td data-bbox="667 1136 1474 1199" style="text-align: center;">100 mg/l</td> </tr> <tr> <td data-bbox="329 1199 667 1262">Chlorides</td> <td data-bbox="667 1199 1474 1262" style="text-align: center;">860 mg/l</td> </tr> <tr> <td data-bbox="329 1262 667 1318">pH</td> <td data-bbox="667 1262 1474 1318" style="text-align: center;">6.0 to 9.0 su</td> </tr> </tbody> </table>	Table VII-I-2 Sector I - Benchmark Monitoring Requirement		<i>Pollutants of Concern</i>	<i>Benchmark Monitoring Cut-off Concentration</i>	Oil and Gas Extraction (SIC Major Group 13)		Total Suspended Solids (TSS)	100 mg/l	Chlorides	860 mg/l	pH	6.0 to 9.0 su
Table VII-I-2 Sector I - Benchmark Monitoring Requirement													
<i>Pollutants of Concern</i>	<i>Benchmark Monitoring Cut-off Concentration</i>												
Oil and Gas Extraction (SIC Major Group 13)													
Total Suspended Solids (TSS)	100 mg/l												
Chlorides	860 mg/l												
pH	6.0 to 9.0 su												

Sector J - Mineral Mining & Dressing

Applicability	<p>The requirements listed under this section apply to <i>stormwater discharges</i> associated with <i>industrial activity</i> from active and inactive mineral mining and dressing facilities as identified by the SIC Major Group 14. The types of activities that <i>owner or operators</i> under Sector J are primarily engaged in are:</p> <ul style="list-style-type: none"> • Exploring for minerals (e.g., stone, sand, clay, chemical and fertilizer minerals, non-metallic minerals, etc.) • Developing mines and the mining of minerals • Mineral dressing • Nonmetallic mineral services. <p>Most <i>stormwater discharges</i> subject to an existing <i>effluent limitation</i> guideline in 40 CFR Part 436 are not authorized by this permit, except for mine dewatering <i>discharges</i> composed entirely of <i>stormwater</i> or ground water seepage from construction sand and gravel, industrial sand, and crushed stone mining facilities.</p>
Limitations of Coverage	<p><i>Stormwater discharges</i> from soils disturbance associated with <i>mining</i> except for reclamation activities where the pre-approved, post-mining use would otherwise require post construction <i>stormwater</i> controls under the <i>SPDES General Permit for Stormwater Discharges from Construction Activity (GP-0-15-002)</i>.</p>
Prohibitions	<p>In addition to the general prohibitions of non-<i>stormwater discharges</i>, the following <i>discharges</i> not covered by this permit include, but are not limited to:</p> <ul style="list-style-type: none"> • Mineral wash water • Transport (slurry) water • Wet scrubber blowdown • Contact cooling water • Noncontact cooling water • Floor and equipment washing • Water used for dust suppression (except as indicated below) • Cooling tower and boiler blowdowns • Vehicle and equipment maintenance fluids • Intake water treatment backwashes. • <i>Stormwater discharges</i> subject to an existing <i>effluent limitation</i> guideline in 40CFR Part 436, except for mine dewatering <i>discharges</i> composed entirely of <i>stormwater</i> or <i>groundwater</i> seepage from construction sand and gravel, industrial sand, and rushed stone mining facilities. <p>These <i>discharges</i> must be covered under a separate <i>SPDES</i> permit.</p>

**Non-Stormwater
discharges**

In addition to the *discharges* described in Part I.B.2, the *discharge* of clean water applied to roadways for dust control may be authorized by this permit provided that *BMPs* are in place to limit application rates thus preventing erosion and minimizing surface runoff.

Definitions

The following definitions are only for this section of the general permit:

"Haulageway" means all roads utilized for mining purposes, together with that area of land over which material is transported, that are located within the permitted area.

"Mine" means any excavation from which a mineral is to be produced for sale or exchange, or for commercial, industrial or municipal use; all haulageways and all equipment above, on or below the surface of the ground used in connection with such excavation, and all lands included in the life of the mine review by the *Department*.

"Mining Activity or Activities" means the activities associated with mining and reclamation including the exploration and land disturbance to determine the financial viability of a site, construction of haulageways, buildings and structures associated with *mining*.

"Mining" means the extraction of overburden and minerals from the earth; the preparation and processing of minerals, including any activities or processes or parts thereof for the extraction or removal of minerals from their original location and the preparation, washing, cleaning, crushing, stockpiling or other processing of minerals at the mine location so as to make them suitable for commercial, industrial, or construction use; exclusive of manufacturing processes, at the mine location; the removal of such materials through sale or exchange, or for commercial, industrial or municipal use; and the disposition of overburden, tailings and waste at the mine location. "Mining" shall not include the excavation, removal and disposition of minerals from construction projects, exclusive of the creation of water bodies, or excavations in aid of agricultural activities.

"Reclamation" means the activities associated with conditioning of the affected land to make it suitable for any uses or purposes consistent with the pre-approved, post mining use.

Note: The following definitions are not intended to supercede the definitions of active and inactive mining facilities established by 40 CFR 122.26(b)(14)(iii).

"Active Mineral Mining Facility" means a place where work or other activity related to the extraction, removal or recovery of minerals is being conducted. This definition does not include any land where grading has returned the earth to a desired contour and reclamation has begun.

"Inactive Mineral Mining Facility" means a site or portion of a site where mineral mining and/or dressing occurred in the past but is not an active facility as defined above, and where the inactive portion is not covered by an active permit issued by the applicable *State* or Federal government agency.

"Mine Dewatering" means any water that is impounded or that collects in the mine and is pumped, drained or otherwise removed from the mine through the efforts of the mine operator. This term shall also include wet pit overflows caused solely by direct rainfall and/or ground water seepage.

"Process Generated Wastewater" means if a mine is also used for treatment of process generated waste water, *discharges* of commingled water from the facilities shall be deemed *discharges* of process generated waste water.

	<p>"<i>Temporarily Inactive Mineral Mining Facility</i>" means a site or portion of a site where mineral mining and/or dressing occurred in the past but currently are not being actively undertaken, and the facility is covered by an active mining permit issued by the applicable <i>State</i> or Federal government agency.</p> <p>"<i>Final Stabilization</i>" means that a site or portion of a site has implemented all applicable Federal and State (6NYCRR §422.3) reclamation requirements.</p>	
SWPPP Requirements in addition to Part III		
Site Map	<p>Document on your site map the locations of the following:</p> <ul style="list-style-type: none"> • Mining or milling site boundaries • Access and haul roads, • Outline of the drainage areas or each <i>stormwater outfall</i> within the facility with indications of the types of <i>discharges</i> from the drainage areas • Location(s) of all permitted <i>discharges</i> covered under an <i>individual SPDES permit</i> • Outdoor equipment storage, fueling, and maintenance areas • Materials handling areas • Outdoor manufacturing, outdoor storage, and material disposal areas • Outdoor chemicals and explosives storage areas • Overburden, materials, soils, or waste storage areas • Location of mine drainage dewatering or other process water • Surface waters • Boundary of tributary areas that are subject to <i>effluent limitations guidelines</i> • Location(s) of reclaimed areas 	
Additional Non-Numeric Effluent Limits		
Erosion and Sediment Control Plan	<p>An erosion and sediment control (ESC) plan must be developed and implemented for <i>mining activities</i> that result in a soil disturbance with the potential for <i>stormwater discharge to surface waters of the State</i>. <u>Areas draining internal to the mine that do not have the potential to discharge to surface waters of the State and areas that have achieved final stabilization are not subject to these requirements.</u> This plan shall include details of temporary and permanent structural and vegetative measures that will be used to control erosion and sedimentation. The design, installation, inspection, maintenance and repair of erosion and sediment controls shall conform to the New York Standards and Specifications for Erosion and Sediment Control, 2016 and New York State Revegetation Procedures Manual: Surface Mining Reclamation, or their equivalents.</p>	
	ESC Inspections	<p>The <i>owner or operator</i> shall have a <i>qualified person</i> conduct site inspections in areas with the potential to <i>discharge to surface waters of the State</i> as follows:</p> <ul style="list-style-type: none"> • All erosion and sediment control practices in areas <u>with potential for stormwater discharge to surface</u>

		<p><u>water</u>, to ensure integrity and effectiveness to ensure that practices are constructed as indicated in the SWPPP.</p> <ul style="list-style-type: none"> • All areas of disturbance in areas with potential for <i>stormwater discharge</i> to surface water that have not achieved <i>final stabilization</i>; • All points of <i>discharge</i> to natural surface waterbodies located within, or immediately adjacent to, the property boundaries of the <i>mine</i>. • All points of <i>discharge</i>.
<p>Erosion and Sediment Control Plan</p>	<p>ESC Inspection Frequency</p>	<p>For sites where soil disturbance activities are on-going, the <i>qualified person</i> shall conduct a site inspection at least once every seven (7) calendar days. Where soil disturbance activities have been temporarily suspended (e.g. winter shutdown) and <i>temporary stabilization</i> has been applied to all disturbed areas or if runoff is unlikely due to winter conditions (e.g., site is covered with snow, ice, or the ground is frozen), the <i>qualified person</i> shall conduct a site inspection at least once every thirty (30) calendar days.</p>

	<p style="text-align: center;">ESC Inspection Reports</p>	<p>At a minimum, the inspection report shall include and/or address the following:</p> <ul style="list-style-type: none"> • Date and time of inspection; • Name and title of person(s) performing inspection; • A description of the weather and soil conditions (e.g. dry, wet, saturated) at the time of the inspection; • A description of the condition of the runoff at all points of <i>discharge</i> from the site. • Identify any <i>discharges</i> of sediment or other <i>pollutants</i> from the site, including <i>discharges</i> from conveyance systems (i.e. pipes, culverts, ditches, etc.) and overland flow; • A description of the condition of all natural surface water bodies located within, or immediately adjacent to, the property boundaries of the construction site which receive runoff from disturbed areas. This shall include identification of any <i>discharges</i> of sediment to the surface water body; • Identification of all <i>BMPs</i> and erosion and sediment control practices that need repair or maintenance • Identification of all <i>BMPs</i> and erosion and sediment control practices that were not installed properly or are not functioning as designed and need to be reinstalled or replaced; • Description and sketch of areas that are disturbed at the time of the inspection and areas that have been stabilized (temporary and/or final) since the last inspection; • Corrective action(s) that must be taken to install, repair, replace or maintain erosion and sediment control practices; and to correct deficiencies identified with the construction of the post-construction <i>stormwater</i> management practice(s)
	<p style="text-align: center;">ESC Inspection Follow-Up</p>	<p>Within one (1) business day of the completion of an inspection, the <i>qualified person</i> shall notify the <i>owner or operator</i> and appropriate contractor of any corrective actions that need to be taken. The <i>owner or operator</i> shall begin implementing the corrective actions within one (1) business day of this notification and shall complete the corrective actions within seven (7) calendar days unless otherwise notified by the <i>Department</i>.</p>

<p style="text-align: center;">Routine Inspections</p>	<p>All <i>BMPs</i> (other than Erosion & Sediment Controls) at the facility shall be inspected quarterly for evidence of actual or potential <i>discharges</i> of contaminated <i>stormwater</i> and shall include the following areas:</p> <ul style="list-style-type: none"> • Chemical handling and storage areas • Vehicle & equipment maintenance areas • Fueling areas • Other potential sources of pollution <p>Temporarily or permanently inactive facilities shall be inspected annually.</p>															
<p style="text-align: center;">Numeric Effluent Limitations</p>	<p>The following <i>effluent limitations</i> shall be met by existing and new <i>discharges</i> from <i>Mine Dewatering</i> activities at construction sand and gravel; industrial sand; and crushed stone mining facilities (SIC 1422–1429, 1442, 1446) in accordance with 40 CFR 436:</p> <p style="text-align: center;">Table VII-J-1. Sector J - Numeric Effluent Limitations</p> <table border="1" data-bbox="329 863 1472 1205"> <thead> <tr> <th data-bbox="329 863 664 926" rowspan="2">Parameter</th> <th colspan="2" data-bbox="664 863 1472 926">Effluent Limitations</th> </tr> <tr> <th data-bbox="664 926 998 982">Daily Maximum</th> <th data-bbox="998 926 1472 982">30-day Average</th> </tr> </thead> <tbody> <tr> <td colspan="3" data-bbox="329 982 1472 1079">Mine Dewatering Activities at Construction Sand and Gravel; Industrial Sand; and Crushed Stone Mining Facilities (SIC 1422–1429, 1442, 1446) Subject to the <i>Point Source</i> Category Provisions of 40CFR Part 436 Subparts B, C & D</td> </tr> <tr> <td data-bbox="329 1079 664 1146">Total Suspended Solids (TSS)</td> <td data-bbox="664 1079 998 1146">45 mg/L</td> <td data-bbox="998 1079 1472 1146">25 mg/L</td> </tr> <tr> <td data-bbox="329 1146 664 1205">pH</td> <td colspan="2" data-bbox="664 1146 1472 1205">6.0 to 9.0 SU</td> </tr> </tbody> </table>		Parameter	Effluent Limitations		Daily Maximum	30-day Average	Mine Dewatering Activities at Construction Sand and Gravel; Industrial Sand; and Crushed Stone Mining Facilities (SIC 1422–1429, 1442, 1446) Subject to the <i>Point Source</i> Category Provisions of 40CFR Part 436 Subparts B, C & D			Total Suspended Solids (TSS)	45 mg/L	25 mg/L	pH	6.0 to 9.0 SU	
Parameter	Effluent Limitations															
	Daily Maximum	30-day Average														
Mine Dewatering Activities at Construction Sand and Gravel; Industrial Sand; and Crushed Stone Mining Facilities (SIC 1422–1429, 1442, 1446) Subject to the <i>Point Source</i> Category Provisions of 40CFR Part 436 Subparts B, C & D																
Total Suspended Solids (TSS)	45 mg/L	25 mg/L														
pH	6.0 to 9.0 SU															
<p style="text-align: center;">Benchmarks</p>	<p>Sand and gravel mining facilities (SIC 1442, 1446) and facilities manufacturing dimension, crushed stone and nonmetallic minerals (except fuels (SIC 1411, 1422-1429, 1481, 1499) are required to monitor their <i>stormwater discharges</i> for the <i>pollutants</i> of concern listed in Table VII-J-2.</p> <p style="text-align: center;">Table VII-J-2 Sector J - Benchmark Monitoring Requirement</p> <table border="1" data-bbox="329 1514 1472 1890"> <thead> <tr> <th data-bbox="329 1514 831 1583"><i>Pollutants of Concern</i></th> <th data-bbox="831 1514 1472 1583"><i>Benchmark Monitoring Cut-off Concentration</i></th> </tr> </thead> <tbody> <tr> <td colspan="2" data-bbox="329 1583 1472 1646">Sand and Gravel Mining (SIC 1442, 1446)</td> </tr> <tr> <td data-bbox="329 1646 831 1709">Total Nitrogen</td> <td data-bbox="831 1646 1472 1709">6 mg/L</td> </tr> <tr> <td data-bbox="329 1709 831 1772">Total Phosphorous (TP)</td> <td data-bbox="831 1709 1472 1772">2 mg/L</td> </tr> <tr> <td data-bbox="329 1772 831 1835">Total Suspended Solids (TSS)</td> <td data-bbox="831 1772 1472 1835">100 mg/L</td> </tr> <tr> <td data-bbox="329 1835 831 1890">Total Recoverable Iron</td> <td data-bbox="831 1835 1472 1890">1 mg/L</td> </tr> </tbody> </table>		<i>Pollutants of Concern</i>	<i>Benchmark Monitoring Cut-off Concentration</i>	Sand and Gravel Mining (SIC 1442, 1446)		Total Nitrogen	6 mg/L	Total Phosphorous (TP)	2 mg/L	Total Suspended Solids (TSS)	100 mg/L	Total Recoverable Iron	1 mg/L		
<i>Pollutants of Concern</i>	<i>Benchmark Monitoring Cut-off Concentration</i>															
Sand and Gravel Mining (SIC 1442, 1446)																
Total Nitrogen	6 mg/L															
Total Phosphorous (TP)	2 mg/L															
Total Suspended Solids (TSS)	100 mg/L															
Total Recoverable Iron	1 mg/L															

Benchmarks (Continued)	Table VII-J-2 (Continued) Sector J - Benchmark Monitoring Requirement	
	<i>Pollutants of Concern</i>	<i>Benchmark Monitoring Cut-off Concentration</i>
	Sand and Gravel Mining (SIC 1442, 1446) (Continued)	
	Total Recoverable Zinc	110 ug/L
	Dimension and Crushed Stone and Nonmetallic Minerals (except fuels) (SIC 1411, 1422-1429, 1481, 1499)	
	Total Suspended Solids (TSS)	100 mg/L
	* Total Nitrogen is calculated as the sum of ammonia, nitrate-nitrite and organic nitrogen	

Sector K – Hazardous Waste Treatment, Storage or Disposal Facilities

Applicability	<p>The requirements listed under this section apply to <i>stormwater discharges associated with industrial activity</i> from facilities that treat, store, or dispose of hazardous wastes, including those that are operating under interim status or a permit under Subtitle C of RCRA (<i>Industrial Activity Code "HZ"</i>). Disposal facilities that have been properly closed and capped, and have no <i>significant materials</i> exposed to <i>stormwater</i>, are considered inactive and do not require permits.</p>
Prohibitions	<p>In addition to the general non-<i>stormwater</i> prohibition in Part I.C.1, the <i>discharges</i> not covered by this permit include, but are not limited to:</p> <ul style="list-style-type: none"> • Leachate • Gas collection condensate • Drained free liquids • Contaminated ground water • Laboratory-derived wastewater • Contact washwater from washing truck, railcar and equipment exteriors and surface areas that have come in direct contact with solid waste or daily cover at the landfill facility. <p>These <i>discharges</i> must be covered under a separate <i>SPDES</i> permit</p>
Definitions	<p><i>The following definitions are only for this section of the general permit:</i></p> <p><i>"Contaminated groundwater"</i> means water below the land surface in the zone of saturation which has been contaminated by activities associated with waste disposal.</p> <p><i>"Contaminated stormwater"</i> means <i>stormwater</i> that comes in direct contact with landfill wastes, the waste handling and treatment areas, or landfill wastewater as defined below. Some specific areas of a landfill that may produce contaminated <i>stormwater</i> include, but are not limited to: the open face of an active landfill with exposed waste (including areas with daily cover); the areas around wastewater treatment operations; trucks, equipment or machinery that has been in direct contact with the waste; and waste dumping areas.</p> <p><i>"Drained free liquids"</i> means aqueous wastes drained from waste containers (e.g., drums, etc.) prior to landfilling.</p>

Definitions (Continued)

"*Land treatment facility*" means a facility or part of a facility at which solid waste, including hazardous waste, is applied onto or incorporated into the soil surface. Such facilities are disposal facilities if the waste will remain after closure.

"*Landfill*" means a disposal facility or part of a facility where solid waste, including hazardous waste, is placed in or on land, and which is not a pile, a land treatment facility, a surface impoundment, an underground injection well, a salt dome formation, a salt bed formation, an underground mine, a cave, or a corrective action management unit.

"*Landfill wastewater*" as defined in 40 CFR Part 445 (Landfills *Point Source Category*) means all wastewater associated with, or produced by, landfilling activities except for sanitary wastewater, noncontaminated *stormwater*, contaminated ground water, and wastewater from recovery pumping wells. Landfill wastewater includes, but is not limited to, leachate, gas collection condensate, drained free liquids, laboratory derived wastewater, contaminated *stormwater* and contact washwater from washing truck, equipment, and railcar exteriors and surface areas that have come in direct contact with solid waste at the landfill facility.

"*Leachate*" means a liquid, including any suspended components or dissolved compounds in the liquid, which has been in contact with or passed through solid waste, including hazardous waste.

"*Noncontaminated stormwater*" means *stormwater* that does not come into direct contact with landfill wastes, the waste handling and treatment areas, or landfill wastewater as defined above. Noncontaminated *stormwater* includes *stormwater* that flows off the final cover of the landfill, runoff from intermediate cover that has not come in contact with leachate or waste and runoff from inactive portions of the landfill which are segregated from active portions of the landfill.

"*Pile*" means any noncontainerized accumulation of solid, nonflowing hazardous waste that is used for treatment or storage and that is not a containment building.

"*Surface impoundment*" or "*impoundment*" means a facility or part of a facility which is a natural topographical depression, human-made excavation, or diked area formed primarily of earthen materials (although it may be lined with human-made materials), which is designed to hold an accumulation of liquid wastes or wastes containing free liquids, and which is not an injection well. Examples of surface impoundments are holding, storage, settling, and aeration pits, ponds and lagoons.

Numeric Effluent Limitations

As set forth at 40 CFR Part 445 Subpart A, the numeric limitations in Table VII-K-1 apply to contaminated *stormwater discharges* from hazardous waste landfills subject to the provisions of RCRA Subtitle C at 40 CFR Parts 264 (Subpart N) and 265 (Subpart N) except for any of the facilities described in subdivisions "a" through "d" of this subsection:

- a. Landfills operated in conjunction with other industrial or commercial operations when the landfill only receives wastes generated by the industrial or commercial operation directly associated with the landfill;
- b. Landfills operated in conjunction with other industrial or commercial operations when the landfill receives wastes generated by the industrial or commercial operation directly associated with the landfill and also receives other wastes provided the other wastes received for disposal are generated by a facility that is subject to the same provisions in 40 CFR Subchapter N as the industrial or commercial operation or the other wastes received are of similar nature to the wastes generated by the industrial or commercial operation;
- c. Landfills operated in conjunction with Centralized Waste Treatment (CWT) facilities subject to 40 CFR Part 437 so long as the CWT facility commingles the landfill wastewater with other nonlandfill wastewater for *discharge*. A landfill directly associated with a CWT facility is subject to this part if the CWT facility *discharges* landfill wastewater separately from other CWT wastewater or commingles the wastewater from its landfill only with wastewater from other landfills; or
- d. Landfills operated in conjunction with other industrial or commercial operations when the landfill receives wastes from public service activities so long as the company owning the landfill does not receive a fee or other remuneration for the disposal service.

**Table VII-K-1.
Sector K - Numeric Effluent Limitations**

Parameter	Effluent Limitations	
	Daily Maximum	30-day Average
Hazardous Waste Treatment, Storage, or Disposal Facilities (Industrial Activity Code "HZ") Subject to the <i>Point Source</i> Category Provisions of 40 CFR Part 445 Subpart A.		
Biochemical Oxygen Demand (BOD5)	220 mg/L	56 mg/L
Total Suspended Solids (TSS)	88 mg/L	27 mg/L
Ammonia	10 mg/L	4.9 mg/L

	Alpha Terpineol	0.042 mg/L	0.019 mg/L
	Aniline	0.024 mg/L	0.015 mg/L
	Benzoic Acid	0.119 mg/L	0.073 mg/L
	Naphthalene	0.059 mg/L	0.022 mg/L
	p-Cresol	0.024 mg/L	0.015 mg/L
	Phenol	0.048 mg/L	0.029 mg/L
	Pyridine	0.072 mg/L	0.025 mg/L
	Arsenic (Total)	1.1 mg/L	0.54 mg/L
Numeric Effluent Limitations (Continued)	Table VII-K-1 (Continued) Sector K - Numeric Effluent Limitations		
	Parameter	Effluent Limitations	
		Daily Maximum	30-day Average
	Hazardous Waste Treatment, Storage, or Disposal Facilities (Industrial Activity Code "HZ") Subject to the <i>Point Source</i> Category Provisions of 40 CFR Part 445 Subpart A. (Continued)		
	Chromium (Total)	1.1 mg/L	0.46 mg/L
	Zinc (Total)	0.535 mg/L	0.296 mg/L
	Total Mercury*	50 ng/L	
	pH	6.0 to 9.0 SU	
	*Mercury analysis shall be by EPA Method 1631		
	Benchmarks	<p><i>Owner or operators</i> with hazardous waste treatment, storage or disposal facilities (TSDFs) are required to monitor their <i>stormwater discharges</i> for the <i>pollutants</i> of concern listed in Table VII-K-2. These <i>benchmark monitoring cut-off concentrations</i> apply to <i>stormwater discharges associated with industrial activity</i> other than contaminated <i>stormwater discharges</i> from landfills subject to the <i>numeric effluent limitations</i> set forth in Table VII-K-1.</p>	
Table VII-K-2 Sector K - Benchmark Monitoring Requirement			
Pollutants of Concern		Benchmark Monitoring Cut-off Concentration	
Hazardous Waste Treatment, Storage, or Disposal Facilities (Industrial Activity Code "HZ")			
Total Nitrogen (TN)		6 mg/L	
Total Suspended Solids (TSS)		100 mg/L	
Chemical Oxygen Demand (COD)		120 mg/L	
Total Recoverable Magnesium		64 ug/L	
Total Recoverable Arsenic	150 ug/L		

	Total Recoverable Cadmium	1.8 ug/L
	Total Cyanide	22 ug/L
	Total Recoverable Lead	69 ug/L
	Total Recoverable Selenium	5 ug/L
	Total Recoverable Silver	3.0 ug/L
	* Total Nitrogen is calculated as the sum of ammonia, nitrate-nitrite and organic nitrogen	

Sector L – Landfills, Land Application Sites and Non-Compliant Landfills

Applicability	<p>The requirements listed under this section apply to <i>stormwater discharges associated with industrial activity</i> from waste disposal at landfills, land application sites, construction and demolition debris landfills, and non-compliant landfills (Industrial Activity Code "LF") that receive or have received <i>industrial wastes</i> (waste that is received from <i>industrial activities</i> at any of the facilities described under 40 CFR Part 122.26(b)(14) categories (i) - (xi)). The requirements listed under this section are intended to apply to initial, as well as ongoing <i>construction activities</i> at landfills. [Note: Non-compliant landfills are solid waste disposal units that are not in compliance with <i>State/federal</i> criteria established under RCRA Subtitle D.] Landfills that have been closed in accordance with 6 NYCRR Part 360 are not required to maintain <i>SPDES</i> permit coverage for <i>stormwater discharges</i> provided that the landfill is or has been maintained under a post closure care program.</p>
Special Conditions	<p>The SWPPP must address the <i>stormwater</i> run-on and run-off control systems needed during the landfill’s construction, operation and closure phases prior to commencement of any soils disturbance of one or more acres of land. The plan must be prepared in accordance with the New York Standards and Specifications for Erosion and Sediment Control, (2016) and the New York State <i>Stormwater</i> Management Design Manual, 2015. If alternative erosion and sediment controls or <i>stormwater</i> management practices are proposed, the <i>owner or operator</i> must demonstrate equivalence to these <i>technical standards</i>.</p> <p>The SWPPP must be kept current and must address effective <i>stormwater</i> controls for all appurtenances and components associated with the landfill, including but not limited to, haul roads, paved areas, associated buildings and structures, landfill surfaces, perimeter ditches and berms.</p>
Prohibitions	<p>In addition to the general non-<i>stormwater</i> prohibition in Part I.C.1, the <i>discharges</i> not covered by this permit include, but are not limited to:</p> <ul style="list-style-type: none"> • Leachate • Gas collection condensate • Drained free liquids • Contaminated ground water • Laboratory wastewater • Contact wash water from washing truck, railcar and equipment exteriors and surface areas that have come in direct contact with solid waste or daily cover at the landfill facility. <p>These <i>discharges</i> must be covered under a separate <i>SPDES</i> permit.</p>
Non-Stormwater discharges	<p><u>Non-<i>stormwater</i> discharge test certification</u> - The <i>discharge</i> test and certification must also be conducted for the presence of leachate and vehicle washwater.</p>

Definitions

The following definitions are only for this section of the general permit:

"*Contaminated groundwater*" means water below the land surface in the zone of saturation which has been contaminated by activities associated with waste disposal.

"*Contaminated stormwater*" means *stormwater* that comes in direct contact with landfill wastes, the waste handling and treatment areas, or landfill wastewater as defined below. Some specific areas of a landfill that may produce contaminated *stormwater* include, but are not limited to: the open face of an active landfill with exposed waste (including areas with daily cover); the areas around wastewater treatment operations; trucks, equipment or machinery that has been in direct contact with the waste; and waste dumping areas.

"*Drained free liquids*" means aqueous wastes drained from waste containers (e.g., drums, etc.) prior to landfilling.

"*Land application facility*" means a site where solid waste is applied to the soil surface or injected into the upper layer of the soil to improve soil quality or provide plant nutrients. Solid waste suitable for this purpose includes, but is not limited to, certain food processing waste, sewage treatment plant sludge and septage.

"*Landfill*" means land or a disposal facility or part of one where solid waste or its residue after treatment is intentionally placed and which is not a land application facility, surface impoundment, injection well or waste pile.

"*Landfill wastewater*" as defined in 40 CFR Part 445 (Landfills *Point Source* Category) means all wastewater associated with, or produced by, landfilling activities except for sanitary wastewater, noncontaminated *stormwater*, contaminated *groundwater*, and wastewater from recovery pumping wells. Landfill wastewater includes, but is not limited to, leachate, gas collection condensate, drained free liquids, laboratory-derived wastewater, contaminated *stormwater* and contact washwater from washing truck, equipment, and railcar exteriors and surface areas that have come in direct contact with solid waste at the landfill facility.

"*Leachate*" means any solid waste in the form of a liquid, including any suspended components in the liquid, that results from contact with or passage through solid waste.

"*Noncontaminated stormwater*" means *stormwater* that does not come into direct contact with landfill wastes, the waste handling and treatment areas, or landfill wastewater as defined above. Noncontaminated *stormwater* includes *stormwater* that flows off the final cover of the landfill, runoff from intermediate cover that has not come in contact with leachate or waste and runoff from portions of the landfill where waste has not yet been disposed of and which are segregated from active portions of the landfill.

"*Surface impoundment*" means a solid waste management facility or part of one that is a natural topographical depression, excavation, or diked area formed primarily of earthen materials (although it may be lined with synthetic materials), that is designed to hold solid waste in semisolid or liquid form and that is not an injection

	well. Examples of surface impoundments are holding, storage, settling, and aeration pits, ponds and lagoons.
SWPPP Requirements in addition to Part III	
SWPPP Preparer	All SWPPPs that require post-construction <i>stormwater</i> management controls shall be prepared by a <i>qualified professional</i> .
Site Map	<p>The site map shall identify where any of the following may be exposed to precipitation/surface runoff:</p> <ul style="list-style-type: none"> • Active and closed landfill cells or trenches • Active and closed land application areas • Locations where open dumping is occurring or has occurred • Locations of any known leachate breakouts or other areas where uncontrolled leachate may commingle with runoff • Leachate collection and handling systems

Summary of Potential Pollutant Sources

The SWPPP shall also include a description of potential *pollutant* sources associated with any of the following:

- Fertilizer, herbicide and pesticide application
- Earth/soil moving
- Waste hauling and loading/unloading
- Outdoor storage of *significant materials* including daily, interim and final cover material stockpiles, as well as, temporary waste storage areas
- Exposure of active and inactive landfill and land application areas
- Uncontrolled leachate flows
- Failure or leaks from leachate collection and treatment systems

Additional Non-Numeric Effluent Limits

Good Housekeeping	<p>The SWPPP shall describe and provide for implementation of <i>BMPs</i> that prevent or <i>minimize</i> the potential of any residual fluids from coming in contact with precipitation/runoff. The SWPPP shall document considerations of the following <i>BMPs</i> (or their equivalents):</p> <ul style="list-style-type: none"> • Protected storage areas for pesticides, herbicides, fertilizer and other significant materials. • A schedule of regular inspections of equipment for leaks, spills, malfunctioning, worn or corroded parts or equipment; • Frequent sweeping of haul and access roads and the use of dry absorbent or wet vacuum cleanup methods, to contain or dispose/recycle residual liquids originating from recyclable containers; • Prohibit the practice of allowing wash water from tipping floors or other processing areas from discharging to the storm sewer system; • A preventive maintenance program for processing equipment; • The plan shall address measures and controls to <i>minimize</i> contact of residual liquids and particulate matter from materials stored indoors or under cover from coming in contact with surface runoff. • Disconnect or seal off all floor drains connected to the storm sewer system • Drums containing liquids, especially oil and lubricants, should be stored: indoors; in a bermed area; in overpack containers or spill pallets; or in similar containment devices; and • Drip pans or equivalent measures shall be placed under any leaking piece of stationary equipment until the leak is repaired. The drip pans shall be inspected for leaks and potential overflow and all liquids properly disposed of in accordance with RCRA requirements.
Good Housekeeping (Continued)	<p>The SWPPP shall document considerations of the following <i>BMPs</i> (or their equivalents):</p> <ul style="list-style-type: none"> • Containment or diversion structures such as dikes, berms, culverts, trenches, elevated concrete pads, and grading installed where appropriate to <i>minimize</i> contact of <i>stormwater</i> runoff with outdoor processing equipment or stored materials; • Diversion of runoff away from storage areas via dikes, berms, containment trenches, culverts and surface grading; • Covers over containment bins, dumpsters, roll-off boxes • Permanent or semi-permanent covers over areas where materials are transferred, stored or stockpiled; • Sediment traps, vegetated swales and strips, catch basin filters and sand filters to facilitate settling or filtering of sediments

Spill Prevention & Response	<p>The SWPPP shall include <i>BMPs</i> to <i>minimize stormwater</i> contamination at loading/unloading areas, and from equipment or container failures. The plan may refer to applicable portions of other existing plans such as SPCC plans required under 40 CFR Part 112. The SWPPP must:</p> <ul style="list-style-type: none"> • Describe spill prevention and response measures to address areas that are potential sources of fluid leaks or spills; • Provide for immediate containment and clean up of spills/leaks. If malfunctioning equipment is responsible for the spill/leak, repairs shall also be conducted as soon as possible; • Specify cleanup procedures including the use of dry absorbents. Where dry absorbent cleanup methods are used, an adequate supply of dry absorbent material shall be maintained on-site. Used absorbent material shall be disposed of properly; • Drip pans or equivalent measures shall be placed under any leaking piece of stationary equipment until the leak is repaired. The drip pans shall be inspected for leaks and potential overflow and all liquids properly disposed of in accordance with RCRA requirements <p>The SWPPP shall document considerations of the following <i>BMPs</i> (or their equivalents):</p> <ul style="list-style-type: none"> • Store drums containing liquids, especially oil and lubricants indoors; in a bermed area; in overpack containers or spill pallets; or in similar containment devices; • Install overfill prevention devices on all fuel pumps or tanks; • Install an alarm and/or pump shut off system should be installed on outdoor equipment with hydraulic reservoirs exceeding 150 gallons in order to prevent draining the tank contents in the event of a line break. Alternatively, the equipment may have a secondary containment system capable of containing the contents of the hydraulic reservoir plus adequate freeboard for precipitation
Preventative Maintenance Program	<p>The <i>owner or operator</i> shall maintain:</p> <ul style="list-style-type: none"> • All containers used for outdoor chemical/<i>significant materials</i> storage to prevent leaking • All elements of leachate collection and treatment systems to prevent commingling of leachate with <i>stormwater</i> • The integrity and effectiveness of any intermediate or final cover (including making repairs to the cover as necessary to <i>minimize</i> the effects of settlement, sinking, and erosion).

Erosion and Sediment Control Plan	<p>An erosion and sediment control (ESC) plan must be developed and implemented for all activities associated with the landfill construction, operation or closure that result in a soil disturbance with the potential for <i>stormwater discharge to surface waters of the State</i>. <u>Stormwater runoff that is handled as leachate and from areas that have achieved final stabilization are not subject to these requirements.</u> This plan shall include details of temporary and permanent structural and vegetative measures that will be used to control erosion and sedimentation for all areas that result in a soil disturbance. The design, installation, inspection, maintenance and repair of erosion and sediment controls shall conform to the New York Standards and Specifications for Erosion and Sediment Control, 2016, or equivalent.</p> <p>If any phase of the landfill construction or closure will result in the disturbance of five (5) or more acres of land at any one time, the <i>owner or operator</i> must obtain approval from the Regional Office <i>stormwater</i> contact person prior to disturbing more than five acres.</p>	
	ESC Inspections	<p>The <i>owner or operator</i> shall have a <i>qualified person</i> conduct site inspections of erosion and sediment controls in areas with <u>potential to discharge to surface water</u> as follows:</p> <ul style="list-style-type: none"> • All erosion and sediment control practices and all post-construction <i>stormwater</i> management practices in areas <u>with potential for stormwater discharge to surface water</u>, to ensure integrity and effectiveness to ensure that practices are constructed as indicated in the SWPPP addressing the operation phase; • All areas of disturbance in areas with potential for <i>stormwater discharge to surface water</i> that have not achieved <i>final stabilization</i>; • All points of <i>discharge</i> to natural surface waterbodies located within, or immediately adjacent to, the property boundaries of the <i>construction activity</i>; and, • All points of <i>discharge</i>.
	ESC Inspection Frequency	<p>For sites where soil disturbance activities are on-going, the <i>qualified person</i> shall conduct a site inspection at least once every seven (7) calendar days.</p> <p>Where soil disturbance activities are on-going and the <i>owner or operator</i> has received authorization to disturb greater than five (5) acres of soil at any one time, the <i>qualified person</i> shall conduct at least two (2) site inspections every seven (7) calendar days. The two (2) inspections shall be separated by a minimum of two (2) full calendar days.</p> <p>Where soil disturbance activities have been temporarily suspended (e.g. winter shutdown) and <i>temporary stabilization</i> measures have been applied to all disturbed areas, the <i>qualified person</i> shall conduct a site inspection at least once every thirty (30) calendar days.</p>

Erosion and Sediment Control Plan	ESC Inspection Reports	<p>At a minimum, the inspection report shall include and/or address the following:</p> <ul style="list-style-type: none"> • Date and time of inspection; • Name and title of person(s) performing inspection; • A description of the weather and soil conditions (e.g. dry, wet, saturated) at the time of the inspection; • A description of the condition of the runoff at all points of <i>discharge</i> from the site. • Identify any <i>discharges</i> of sediment or other <i>pollutants</i> from the site, including <i>discharges</i> from conveyance systems (i.e. pipes, culverts, ditches, etc.) and overland flow; • A description of the condition of all natural surface water bodies located within, or immediately adjacent to, the property boundaries of the site which receive runoff from disturbed areas. This shall include identification of any <i>discharges</i> of sediment to the surface water body; • Identification of all <i>BMPs</i> and erosion and sediment control practices that need repair or maintenance • Identification of all <i>BMPs</i> and erosion and sediment control practices that were not installed properly or are not functioning as designed and need to be reinstalled or replaced; • Description and sketch of areas that are disturbed at the time of the inspection and areas that have been stabilized (temporary and/or final) since the last inspection; • Corrective action(s) that must be taken to install, repair, replace or maintain erosion and sediment control practices; and to correct deficiencies identified with the construction of the post-construction <i>stormwater</i> management practice(s) • Digital photographs, with date stamp, that clearly show the condition of all practices that have been identified as needing corrective actions. The <i>qualified person</i> shall attach paper color copies of the digital photographs to the inspection report being maintained onsite within seven (7) calendar days of the date of the inspection. The <i>qualified person</i> shall also take digital photographs, with date stamp, that clearly show the condition of the practice(s) after the corrective action has been completed. The <i>qualified person</i> shall attach paper color copies of the digital photographs to the inspection report that documents the completion of the corrective action work within seven (7) calendar days of that inspection • An inspection report shall be completed and signed by the <i>qualified person</i> for each inspection. All inspection reports shall be maintained on site with the SWPPP.
	ESC Inspection Follow-Up	<p>Within one (1) business day of the completion of an inspection, the <i>qualified person</i> shall notify the <i>owner or operator</i> and appropriate contractor of any corrective actions that need to be</p>

		<p>taken. The <i>owner or operator</i> shall begin implementing the corrective actions within one (1) business day of this notification and shall complete the corrective actions within seven (7) calendar days unless otherwise notified by the <i>Department</i>.</p>
<p style="writing-mode: vertical-rl; transform: rotate(180deg);">Post Construction Stormwater Management Controls</p>	<p><i>Stormwater</i> runoff from all <i>impervious areas</i> that is not handled as leachate shall be captured and treated by post-construction <i>stormwater</i> management controls. The design, construction and maintenance of all post-construction <i>stormwater</i> management controls shall conform to the New York State <i>Stormwater</i> Management Design Manual, 2015. If alternative post construction controls are proposed, the <i>owner or operator</i> must demonstrate equivalence to this technical standard.</p>	
		<p>At a minimum, the post-construction <i>stormwater</i> management practice component of the SWPPP shall include the following:</p> <ol style="list-style-type: none"> a. Identification, dimensions, material specifications and installation details of all post-construction <i>stormwater</i> management practices to be constructed; b. A site map/construction drawing(s) at a scale of 1" = 50' or less, showing the specific location and size of each post-construction <i>stormwater</i> management practice; c. A <i>Stormwater</i> Modeling and Analysis Report that includes: <ol style="list-style-type: none"> 1. Map(s) showing pre-development conditions, including watershed/subcatchment boundaries, flow paths/routing, and design points; 2. Map(s) showing post-development conditions, including watershed/subcatchments boundaries, flow paths/routing, design points and post-construction <i>stormwater</i> management practices; 3. Results of <i>stormwater</i> modeling (i.e. hydrology and hydraulic analysis) for the required storm events. Include supporting calculations (model runs), methodology, and a summary table that compares pre and post-development runoff rates and volumes for the different storm events; 4. Summary table, with supporting calculations, which demonstrate that each post-construction <i>stormwater</i> management practice has been designed in conformance with the sizing criteria included in the 2015 New York State <i>Stormwater</i> Management Design Manual; 5. Identification of any sizing criteria that is not required based on the waiver criteria included in the 2015 New York State <i>Stormwater</i> Management Design Manual; and 6. Identification of any elements of the design that are not in conformance with the 2015 New York State <i>Stormwater</i> Management Design Manual. Include the identification of and justification for any deviations from the 2015 New York State <i>Stormwater</i> Management Design Manual; d. Soil test results (test pit, borings); e. Infiltration test results, when required; and f. An operations and maintenance plan that includes inspection and maintenance schedules and actions to ensure continuous and effective operation of each post-construction <i>stormwater</i> management practice. The plan shall identify the entity that will be responsible for the long term operation and maintenance of each practice and a description of applicable easements, vegetative requirements, access and safety issues, and testing and disposal of sediments as they are removed.

Post Construction Stormwater Management Controls (Continued)	<p>Enhanced Phosphorus Removal Standards – Landfills that are located in the following watersheds shall prepare a SWPPP that includes post-construction <i>stormwater</i> management practices designed in conformance with the Enhanced Phosphorus Removal Standards included in the applicable version of the New York State <i>Stormwater</i> Management Design Manual.</p> <ul style="list-style-type: none"> • New York City East of Hudson Drinking Water Supply Watershed • Onondaga Lake Watershed • Greenwood Lake Watershed • Oscawana Lake Watershed
Routine Inspections	<p>All <i>BMPs</i> (other than Erosion & Sediment Controls) at facilities shall be inspected by a <i>qualified person</i> for evidence of actual or potential <i>discharges</i> of contaminated <i>stormwater</i> and shall include the following areas:</p> <ul style="list-style-type: none"> • Chemical handling and storage areas • Vehicle & Equipment Maintenance Areas • Fueling Areas • Active land application areas • Areas used for storage of materials/wastes that are exposed to precipitation • Leachate collection and treatment systems • Locations where equipment and waste trucks enter and exit the site • Other potential sources of pollution <p>Temporarily or permanently inactive facilities shall be inspected annually</p>
Routine Inspection Frequencies	<p><u>Operating landfills</u>, non-compliant landfills, and land application sites shall be inspected at least once every seven days.</p> <p><u>Inspections of inactive sites</u> - Inactive landfills, non-compliant landfills, and land application sites shall be inspected at least quarterly. A <i>qualified person</i> shall inspect landfill stabilization and structural erosion <i>control measures</i> and leachate collection and treatment systems, and all closed land application areas</p>
Employee Training	<p>Training and Education – Staff must be trained in prevention of contamination to <i>stormwater</i>. In addition to the requirements in Part III, training topics must include</p> <ul style="list-style-type: none"> • Identification of material that is not accepted at the facility • How to identify and remedy leaky containers • Dry clean up methods. <p>The <i>owner or operator</i> must educate incoming drivers on:</p> <ul style="list-style-type: none"> • Materials not accepted by the facility • Preventing contamination to <i>stormwater</i> from leaky vehicles • Prohibition of non-<i>stormwater discharges</i>, including but not limited to waste water from truck washout.

Numeric Effluent Limitations

As set forth at 40 CFR Part 445 Subpart B, the numeric *effluent limitations* in Table VII-L-1 apply to:

1. contaminated *stormwater discharges* from municipal solid waste landfills (MSWLFs) that have not been closed in accordance with 40 CFR 258.60; and,
2. contaminated *stormwater discharges* from those landfills that are subject to the provisions of 40 CFR Part 257 except for *discharges* from any of the facilities described in subdivisions "a" through "d" of this subsection:
 - a. Landfills operated in conjunction with other industrial or commercial operations when the landfill receives only wastes generated by the industrial or commercial operation directly associated with the landfill;
 - b. Landfills operated in conjunction with other industrial or commercial operations when the landfill receives wastes generated by the industrial or commercial operation directly associated with the landfill and also receives other wastes provided the other wastes received for disposal are generated by a facility that is subject to the same provisions in 40 CFR Subchapter N as the industrial or commercial operation or the other wastes received are of a nature similar to the wastes generated by the industrial or commercial operation;
 - c. Landfills operated in conjunction with centralized waste treatment (CWT) facilities subject to 40 CFR Part 437 so long as the CWT facility commingles the landfill wastewater with other non-landfill wastewater for *discharge*. A landfill directly associated with a CWT facility is subject to this part if the CWT facility *discharges* landfill wastewater separately from other CWT wastewater or commingles the wastewater from its landfill only with wastewater from other landfills; or
 - d. Landfills operated in conjunction with other industrial or commercial operations when the landfill receives wastes from public service activities so long as the company owning the landfill does not receive a fee or other remuneration for the disposal service

**Table VII-L-1.
Sector L - Numeric Effluent Limitations**

Parameter	Effluent Limitations	
	Daily Maximum	30-day Average
Landfills (Industrial Activity Code "LF") That Are Subject to the <i>Point Source</i> Category Provisions of 40 CFR Part 445 Subpart B.		
Biochemical Oxygen Demand (BOD5)	140 mg/L	37 mg/L
Total Suspended Solids (TSS)	88 mg/L	27 mg/L
Ammonia	10 mg/L	4.9 mg/L
Alpha Terpineol	0.033 mg/L	0.016 mg/L
Benzoic Acid	0.12 mg/L	0.071 mg/L
p-Cresol	0.025 mg/L	0.014 mg/L

	Phenol	0.026 mg/L	0.015 mg/L
	Zinc (Total)	0.20 mg/L	0.11 mg/L
	pH	6.0 to 9.0 SU	
Benchmarks	Landfill and land application sites are required to monitor their <i>stormwater discharges</i> for the <i>pollutants</i> of concern listed in Table VII-L-2. These <i>benchmark monitoring cut-off concentrations</i> apply to <i>stormwater discharges associated with industrial activity</i> other than contaminated <i>stormwater discharges</i> from landfills subject to the numeric <i>effluent limitations</i> set forth in Table VII-L-1.		
	Table VII-L-2 Sector L - Benchmark Monitoring Requirements		
	Pollutants of Concern	Benchmark Monitoring Cut-off Concentration	
	Landfills, Land Application Sites and Non-Compliant Landfills (Industrial Activity Code "LF").		
	Total Suspended Solids (TSS)	100 mg/L	
	Total Nitrogen (TN)*	6 mg/L	
	Total Phosphorus (TP)	2 mg/L	
	Total Recoverable Iron	1 mg/L	
	Landfills, Land Application Sites and Non-Compliant Landfills, Except Municipal Solid Waste Landfill Areas Closed in Accordance With 40 CFR 258.60 (Industrial Activity Code "LF")		
	Total Suspended Solids (TSS)	100 mg/L	
	Total Recoverable Iron	1 mg/L	
	* Total Nitrogen is calculated as the sum of ammonia, nitrate-nitrite and organic nitrogen		

Sector M - Automobile Salvage Yards

Applicability	<p>The requirements listed under this section apply to <i>stormwater discharges associated with industrial activity</i> from facilities engaged in dismantling or wrecking used motor vehicles for parts recycling/resale and for scrap (SIC Code 5015).</p>
Prohibitions Non -Stormwater discharges	<p>In addition to the general prohibition of non-<i>stormwater discharges</i> in Part I.C.1, the following <i>discharges</i> not covered by this permit include, but are not limited to:</p> <ul style="list-style-type: none"> • <i>Discharges</i> of vehicle, equipment, and floor wash water <p>All wash water <i>discharges</i> must be authorized under a separate <i>SPDES</i> permit or <i>discharged</i> to a sanitary sewer in accordance with applicable industrial pretreatment requirements.</p>
SWPPP Requirements in addition to Part III	
Site Map	<p>The site map must identify where any of the following may be exposed to precipitation/surface runoff:</p> <ul style="list-style-type: none"> • Vehicle storage areas; • Dismantling areas • Parts storage areas (e.g., engine blocks, tires, hub caps, batteries, hoods, mufflers) • Liquid storage tanks and drums for fuel and other fluids • Location of each <i>discharge</i> and monitoring poin <p>An estimation (in acres) of the total area used for <i>industrial activity</i> including, but not limited to:</p> <ul style="list-style-type: none"> • Dismantling • Storage • Maintenance of used motor vehicle parts
Summary of Potential Pollutant Sources	<p>The <i>owner or operator</i> must assess the potential for the following activities to contribute <i>pollutants</i> to <i>stormwater discharges</i>:</p> <ul style="list-style-type: none"> • Vehicle storage areas • Dismantling areas • Parts storage areas (e.g., engine blocks, tires, hub caps, batteries, and hoods) • Fueling stations

Additional Non-Numeric Effluent Limits

Good Housekeeping Measures

Vehicle Dismantling & Maintenance Areas

The SWPPP must describe *BMPs* that prevent or *minimize* contamination of *stormwater* runoff from all areas used for vehicle dismantling and maintenance. The SWPPP shall document considerations of the following *BMPs* (or their equivalents):

- Inspect all incoming vehicles for leaks and take appropriate actions to prevent the release of automobile fluids to the ground;
- Remove fuel, refrigerants and the battery as soon as possible;
- Vehicle draining and dismantling activities must be conducted in a bermed area, constructed of concrete or other surfaces that allows equivalent protection to *groundwater*;
- The dismantling area should also be covered;
- Promptly transfer any drained fluids to segregated storage containers that are properly labeled and in good condition (e.g, anti-freeze, gasoline, used oil, transmission fluid, brake fluids, window washer fluid) for reuse or recycling;
- Drain and collect all fluids to the maximum extent practicable in accordance with best available industry standards from engines, radiators, transmissions, heater core, brake fluid reservoirs, differentials, hoses, fuel tanks, air conditioning units and window washing fluids before crushing or storage over bare ground;
- When pulling parts from vehicles in the yard, employ a catch sled or tray to recover the majority of fluids which will be released.
- Place drip pans, large plastic sheets, or canvas under vehicles or equipment during maintenance and dismantling activities.
- Where drip pans are used, care should be taken to prevent accidental spills.
- Properly store batteries for recycling or resale;
- Store cracked batteries in a non-leaking covered container;
- Do not pour liquid waste down floor drains, sinks, or outdoor storm drain inlets;
- Plug floor drains that are connected to the storm or sanitary sewers;
- Vehicle dismantling activities shall include removal of lead acid batteries, other lead parts such as tire weights and battery cable ends, mercury switches, other mercury containing parts for recycling;
- Recover air conditioner refrigerants using EPA certified recycling equipment;
- Maintain an organized inventory of materials used in the maintenance shop;
- Nonhazardous substances that are contaminated with a hazardous substance are considered to be a hazardous substance;
- Dispose of greasy rags, air filters, and degreasers properly;
- Label and track the recycling of waste material (e.g., used oil, spent solvents, batteries);
- Drain oil and transmission filters before disposal or recycling;
- Inspect the maintenance area regularly for proper implementation of *control measures*;
- Use dry cleanup methods and prohibit the practice of hosing down the shop floor;
- Recycle mineral spirits and solvents;
- Provide treatment of *stormwater discharges* with devices such as oil-water separators;
- Train employees on proper waste control and disposal procedures

<p style="text-align: center;">Vehicle Parts and Equipment Storage Areas</p>	<p>The SWPPP must describe <i>BMPs</i> that prevent or <i>minimize</i> contamination of the <i>stormwater</i> runoff from vehicle, parts and equipment storage areas. The SWPPP shall document considerations of the following <i>BMPs</i> (or their equivalents):</p> <ul style="list-style-type: none"> • Use drip pans under all vehicles and equipment waiting for maintenance and during maintenance; • using dry-absorbents or other cleanup practices to collect and dispose of or recycle spilled or leaking fluids or use mercury spill kits for spills from storage of mercury switches • Use large plastic or metal bins with secure lids to store oily parts (e.g., small engine parts); • Install curbing, berms or dikes around storage areas; • Confine storage of parts, equipment and vehicles to designated areas; • Cover all parts storage areas with a permanent cover (e.g., roofs) or temporary cover (e.g., canvas tarps); • Store used batteries within non-leaking secondary containment or by other equivalent means to prevent leaks of acid into <i>stormwater discharges</i>; • Inspect the storage yard for filling drip pans and other problems regularly; and • Train employees on procedures for storage and inspection items.
<p style="text-align: center;">Vehicle, Equipment, and Parts Cleaning Areas</p>	<p>The SWPPP must describe <i>BMPs</i> that prevent or <i>minimize</i> contamination of <i>stormwater</i> from all areas used for vehicle, equipment, and parts cleaning. The SWPPP shall document considerations of the following <i>BMPs</i> (or their equivalents):</p> <ul style="list-style-type: none"> • Avoid washing parts or equipment outside; • Designate an area for cleaning activities; • Install curbing, berms or dikes around cleaning areas; • Consider using detergent-based or water-based cleaning systems in place of organic solvent degreasers; • Use phosphate-free biodegradable detergents; • Contain steam cleaning wash waters* or <i>discharge</i> under an applicable <i>SPDES</i> permit; • Inspect cleaning area regularly; • Train employees on proper washing procedures <p>*Wash waters from vehicle, equipment, and parts cleaning areas are process wastewaters that are not authorized <i>discharges</i> under this section.</p>

<p style="text-align: center;">Liquid Storage Areas</p>	<p>The SWPPP must describe <i>BMPs</i> that prevent or <i>minimize</i> contamination of the <i>stormwater</i> runoff from all areas used for liquid storage. The SWPPP shall document considerations of the following <i>BMPs</i> (or their equivalents):</p> <ul style="list-style-type: none"> • Maintain good integrity of all storage containers; • Provide containment and a roof over liquid storage areas; • Inspect storage tanks to detect potential leaks and perform preventive maintenance; • Inspect piping systems (pipes, pumps, flanges, couplings, hoses, and valves) for failures or leaks; • Train employees on proper filling and transfer procedures
<p style="text-align: center;">Inspections</p>	<p>Routine facility inspections conducted by qualified facility personnel identified in Part IV.B shall include, but is not limited to the following:</p> <ul style="list-style-type: none"> • All incoming vehicles upon arrival at the site for leakage; • Outdoor storage of vehicles, parts or equipment for leakage at least quarterly; • Outdoor storage of fluids in tanks or containers for leakage at least quarterly; • Prior to crushing, spot check vehicles for removal of fluids, battery, mercury switches, lead battery connectors, lead tire balance weights, PCB capacitors, etc.
<p style="text-align: center;">Employee Training</p>	<p>The SWPPP must include details about an employee training program. Training must be conducted annually at a minimum; however, more frequent training may be necessary at facilities with high employee turnover. Employee training must, at a minimum, address the following areas when applicable to a facility:</p> <ul style="list-style-type: none"> • Used oil management • Spill prevention and response • Purpose, function and maintenance of erosion and sediment control practices; • Good housekeeping practices; • Used battery management; • Removal of parts containing mercury, • Lead and PCBs, • Proper handling (i.e., collection, storage, and disposal) of all fluids • Identification of unpermitted <i>discharges</i> from floor drains, sinks, or outdoor storm drain inlets. • Condition and maintenance needs of <i>stormwater</i> controls • Sump maintenance (regular pumping, use of pads around perimeter to prevent unwanted hazardous materials from entering, etc..) • Condition and maintenance needs for oil water separators, filters and screens used to remove sludges and solids before they reach waste sumps. • Prohibition of the practice of hosing down the shop floor

	<ul style="list-style-type: none"> • Use of dry cleanup methods, and/or collecting the <i>stormwater</i> runoff from the maintenance area
Management of runoff	<p>The SWPPP must consider management practices, such as berms or drainage ditches on the property line that may be used to prevent run-on from neighboring properties. Berms must be considered for uncovered outdoor storage of oily parts, engine blocks, and aboveground liquid storage. The <i>owner or operator</i> shall consider the installation of detention ponds, filtering devices, and oil/water separators.</p> <p>Consider using green infrastructure practices such as vegetated swales and constructed wetlands to reduce export of metals in <i>stormwater</i>.</p>
Minimize Exposure	<p>Minimizing exposure prevents <i>pollutants</i>, including waste metal, spare parts, engine blocks and other debris, from coming into contact with precipitation and can reduce the need for <i>BMPs</i> to treat contaminated <i>stormwater</i> runoff. Examples of <i>BMPs</i> for exposure minimization include:</p> <ul style="list-style-type: none"> • Covering materials or activities with temporary structures (e.g., tarps) when wet weather is expected • Moving materials or activities to existing or new permanent structures (e.g., buildings, silos, sheds). • Consolidating processing activities to an area that is covered and bermed with impermeable concrete surface equipped with a drain, where all fluids are drained.
Erosion & Sediment Control Plan	<p>The SWPPP must include an Erosion and Sediment Control plan (ESC plan) addressing the storm water run-on and run-off control systems in all areas of the facility. The ESC plan must be developed by a <i>qualified person</i> and implemented by the <i>owner or operator</i>. The plan must be prepared in accordance the New York Standards and Specifications for Erosion and Sediment control, 2016, or equivalent. Consider using sediment traps, vegetated swales and strips, catch basin filters and sand filters to facilitate settling or filtering of sediments.</p>
Spill & Leak Prevention	<ul style="list-style-type: none"> • As indicated in Part II.A.4, the <i>discharge</i> of hazardous substances or petroleum in the <i>stormwater discharge(s)</i> from the facility shall be prevented or <i>minimized</i> in accordance with the <i>stormwater</i> pollution prevention plan for the facility.

	<ul style="list-style-type: none"> • Any spill of petroleum must be reported in accordance with 6 NYCRR Part 613.8. Any spill of a hazardous substance must be reported in accordance with 6 NYCRR Part 595.3. • Notification must be reported to the DEC Spill hotline (1-800- 457-7362) within two hours of identifying a release. Spills or leaks outside of containment areas shall be cleaned up immediately and spills or leaks within containment shall be controlled immediately and cleaned up as stated in Part II.A.4. • After clean up from a spill, absorbents must be promptly placed in containers for proper disposal. • All vehicles that are intended to be dismantled must be properly drained of all fluids prior to being dismantled or crushed, or other equivalent means must be taken to prevent leaks or spills of fluids including motor oil, transmission fluid, fuel and antifreeze. • Use mercury spill kits for spills from storage of mercury switches
Guidance in Development of SWPPPs	<p><i>Owner or operators</i> operating facilities engaged in dismantling or wrecking used motor vehicles for parts recycling/resale and for scrap (SIC Code 5015) must review the following guidance documents to ensure that operating practices meet regulatory requirements and follow pollution prevention measures which will <i>minimize</i> waste and promote environmental compliance.</p> <p>a. NYSDEC’s <u>Environmental Compliance and Pollution Prevention Guide for Automobile Recyclers</u> , January 2003</p> <p>b. <u>Auto Recyclers Guide to a Cleaner Environment - Best Management Practices</u>, April 2001, prepared by the Monroe County Small Business Pollution Prevention Task Force and NYSDEC</p> <p>c. Industrial Fact Sheet Series for Activities Covered by EPA’s MSGP <u>Sector M: Automobile Salvage Yards (PDF)</u> (EPA 833-F-06-028) http://cfpub.epa.gov/npdes/stormwater/swsectors.cfm</p> <p>d. Other helpful information for Vehicle Dismantlers is also available on the <i>Department’s</i> web site at http://www.dec.ny.gov/chemical/8505.html</p>
N u m e r . . .	

	No Numeric Effluent Limits specified for this sector.	
Benchmarks	Automobile salvage yards are required to monitor their <i>stormwater discharges</i> for the <i>pollutants</i> of concern listed in Table VII-M-1.	
	Table VII-M-1 Sector M - Benchmark Monitoring Requirement	
	Pollutants of Concern	Benchmark Monitoring Cut-off Concentration
	Automobile Salvage Yards (SIC 5015)	
	Total Suspended Solids (TSS)	100 mg/L
	Oil & Grease	15 mg/L
	Benzene	50 ug/L
	Ethylbenzene	50 ug/L
	Toluene	50 ug/L
	Xylene	50 ug/L
	Total Recoverable Aluminum	750 ug/L
	Total Recoverable Iron	1 mg/L
Total Recoverable Lead	69 ug/L	

Sector N – Scrap Recycling & Waste Recycling Facilities

Applicability	<p>The requirements listed under this section apply to <i>stormwater discharges associated with industrial activity</i> from facilities engaged in:</p> <ul style="list-style-type: none"> • Processing, reclaiming and wholesale distribution of scrap (including, but not limited to facilities with activities described by SIC code 5093) • Waste recycling facilities, including recycling facilities commonly referred to as material recovery facilities (MRFs). • Transfer stations with recycling activities, including the collection of source-separated recyclables • Ship dismantling, marine salvaging, and marine wrecking of ships for scrap (SIC 4499). Other activities listed under SIC 4499 are covered in Sector Q. <p>Vehicle salvage yards engaged in reclaiming and wholesale distribution of used motor vehicle parts (SIC code 5015) are included in Sector M.</p>
Prohibitions Non -Stormwater discharges	<p>In addition to the general non-<i>stormwater</i> prohibition in Part I.C.1, non-<i>stormwater discharges</i> from turnings containment areas are not covered by this permit. <i>Discharges</i> from containment areas in the absence of a storm event are prohibited unless covered by a separate <i>SPDES</i> permit</p> <p>Battery re-claimers engaged in breaking up of used lead-acid batteries are not eligible for coverage under this permit.</p> <p>All wash water <i>discharges</i> must be authorized under a separate <i>SPDES</i> permit or <i>discharged</i> to a sanitary sewer in accordance with applicable industrial pretreatment requirements.</p>
Special Conditions	<p>If any vehicle dismantling activities occur at this facility, the <i>owner or operator</i> must also comply with applicable industry specific requirements outlined in Sector M - Automobile Salvage Yards</p>

Subsector Definitions	N-1	Recycling activities at transfer stations, landfills and other facilities engaged in the collection of source-separated recyclables such as aluminum and tin cans; plastic and glass containers; newspapers and cardboard from institutional, commercial/non-industrial and residential sources.
	N-2	Recycling activities at transfer stations, landfills and other facilities that receive a mixed wastestream of non-recyclable and recyclable wastes.
	N-3	Scrap and waste recycling (non-liquid wastes). Individual scrap and waste recycling facilities may process one or more types of recyclable materials, including but not limited to ferrous and nonferrous metals, paper, plastic, cardboard, glass, animal hides. Activities at facilities included in this subsector typically include scrap waste stockpiling; material processing; segregating processed materials into uniform grades; and collecting non-recyclable materials for disposal
	N-4	Facilities included in other Sector N subsectors that operate a shredder
	N-5	Facilities engaged in the reclaiming and recycling of liquid wastes such as used oil, antifreeze, mineral spirits, industrial solvents and liquid wastes.
	N-6	Facilities engaged in dismantling ships, marine salvaging, and marine wrecking of ships for scrap

SWPPP Requirements in Addition to Part III

In addition to the requirements of Part III, all facilities covered under Sector N are required to comply with following general requirements as well as the requirements applicable to each applicable subsector. Included in each section below, are lists of *BMP* options that, along with any functional equivalents, shall be considered for implementation. *Discharges* of precipitation from containment areas containing used oil shall also be in accordance with applicable sections of 40 CFR Part 112.

At a minimum the *owner or operator* must evaluate the applicability of the *BMPs* in this section. Per Part III.E, if the *owner or operator* concludes that any of the following *BMPs* are not appropriate for the facility, a written explanation of why any of these *BMPs* are not appropriate shall be included in the SWPPP.

<p style="text-align: center;">Site Map</p>	<p>The site map shall identify the locations where the following activities or sources may be exposed to precipitation/surface runoff:</p> <ul style="list-style-type: none"> • Locations of haul and access roads • Scrap and waste material storage areas • Outdoor scrap and waste processing equipment • Areas where materials are sorted, transferred, stockpiled • Containment areas. 	
Additional Non-Numeric Effluent Limits		
<p style="text-align: center;">Discharges to Copper Impaired Waters</p>	<p>If the facility discharges to a Copper Impaired waterbody, the owner or operator shall prevent the exposure of copper sources and copper containing materials or processes to <i>stormwater</i>. These materials shall be protected by a storm-resistant shelter to prevent exposure to rain, snow, snowmelt, and/or runoff.</p>	
Best Management Practices		
<p style="text-align: center;">BMPs – All Facilities</p>	<p>Inbound Waste Control Program</p>	<p>The SWPPP shall include a program to control materials received for processing:</p> <ul style="list-style-type: none"> • Notify suppliers/public which scrap materials will not be accepted at the facility or are only accepted under certain conditions • Develop and implement procedures to inspect inbound shipments of recyclable materials • Develop and distribute educational material targeting the public and/or commercial drivers of inbound vehicles; • Training targeted for personnel engaged in the inspection and acceptance of inbound recyclable materials.
	<p>Particulates</p>	<p>The plan shall address <i>BMPs</i> to <i>minimize</i> contact of particulate matter from materials stored indoors or under cover from coming in contact with surface runoff. The SWPPP shall document considerations of the following <i>BMPs</i> (or their equivalents):</p> <ul style="list-style-type: none"> • Good housekeeping measures, including frequent sweeping of haul and access roads and the use of dry absorbent or wet vacuum clean up methods, to contain or dispose/recycle residual liquids originating from recyclable containers

		<ul style="list-style-type: none"> • Good housekeeping measures to prevent the accumulation of particulate matter and fluids, particularly in high traffic areas.
BMPs – All Facilities (Continued)	Stockpiled materials, processed materials and Non Recyclable Wastes	<p>The SWPPP must describe <i>BMPs</i> to <i>minimize</i> contact of <i>stormwater</i> runoff with stockpiled materials, processed materials and non-recyclable wastes. The SWPPP shall document considerations of the following <i>BMPs</i> (or their equivalents):</p> <ul style="list-style-type: none"> • Store the equivalent one day's volume of recyclable materials indoors; • Containment or diversion structures such as dikes, berms, culverts, trenches, elevated concrete pads, and grading installed where appropriate to <i>minimize</i> contact of <i>stormwater</i> runoff with outdoor processing equipment or stored materials; • Diversion of runoff away from storage areas via dikes, berms, containment trenches, culverts and surface grading; • Cover containment bins, dumpsters, roll off boxes; • Permanent or semi permanent covers over areas where materials are transferred, stored or stockpiled; • Install a sump/pump with each containment pit, and <i>discharge</i> collected fluids to a sanitary sewer system; • Sediment traps, vegetated swales and strips, catch basin filters and sand filters to facilitate settling or filtering of sediments;
	Residual Liquids & Fluids	<p>The plan shall address <i>BMPs</i> to <i>minimize</i> contact of residual liquids and particulate matter from materials stored indoors or under cover from coming in contact with surface runoff. The SWPPP shall document considerations of the following <i>BMPs</i> (or their equivalents):</p> <ul style="list-style-type: none"> • Prohibit the practice of allowing washwater from tipping floors or other processing areas from discharging to the storm sewer system • Disconnect or seal off all floor drains connected to the storm sewer system; • Drums containing liquids, especially oil and lubricants, should be stored: indoors; in a bermed area; in overpack containers or spill pallets; or in similar containment devices; • Drip pans or equivalent measures shall be placed under any leaking piece of stationary equipment until the leak is repaired. The drip pans shall be inspected for leaks and potential overflow and all liquids properly disposed of in accordance with RCRA requirements

		<ul style="list-style-type: none"> Liquid wastes, including used oil, shall be stored in materially compatible and non leaking containers, and be disposed or recycled in accordance with all requirements under the Resource Recovery and Conservation Act (RCRA), and <i>State</i> or local requirements
<p>Facilities with activities described by subsector definitions must comply with the applicable requirements in this section in addition to the general Sector N requirements (above), and the requirements of Part III.</p>		
N-1 & N-2	Inbound Waste Control Program	<p>Provide totally enclosed drop off containers for the public whenever possible. When determined to be impractical, the SWPPP must describe the measures implemented to either prevent the <i>discharge</i> of contaminated <i>stormwater</i> from containers, or the containers should be subject to screening and monitoring required in Part IV.F.1.</p>
N-3 & N-4	Inbound Recycleable & Waste Control Program	<p>Facilities must develop and implement a program to control what is received at the facility. Such plan shall include:</p> <ul style="list-style-type: none"> Provisions for information/education flyers, brochures and pamphlets to suppliers of scrap and recyclable waste materials on: <ul style="list-style-type: none"> Draining and proper recycling/disposal of residual fluids prior to delivery to the facility when applicable (e.g., from vehicles and equipment engines, radiators, and transmissions, oil filled transformers, and individual containers or drums); Removal and proper collection, recycling and/or disposal of mercury switches, mercury containing parts, lead tire weights, lead battery cable ends air conditioning refrigerants, and small PCB capacitors from vehicles; and Removal and proper collection/disposal of PCB capacitors, ballasts, CFCs/HCFCs, mercury switches, mercury containing components and other sources of potential contaminants from appliances Procedures to require certification by suppliers of inbound shipments of recyclable materials that the items identified above were completed Procedures to inspect inbound shipments of recyclable materials to ensure that the items identified above were completed
	Lead Battery Program	<p>Facilities accepting lead acid batteries must develop and implement a scrap lead acid battery program The plan shall address measures and controls for the proper handling, storage and disposal of scrap lead acid batteries. The SWPPP shall document decisions relating to the following <i>BMP</i> options:</p>

		<ul style="list-style-type: none"> • Segregate scrap lead acid batteries from other scrap materials; • A description of procedures and/or measures for the proper handling, storage and disposal of cracked or broken batteries; • A description of measures to collect and dispose of leaking lead acid battery fluid; • A description of measures to <i>minimize</i> and, whenever possible, eliminate exposure of scrap lead acid batteries to precipitation or runoff; and, • A description of employee training for the management of scrap batteries
<p style="text-align: center;">N-3 & N-4 (Continued)</p>	<p style="text-align: center;">Residual Fluids</p>	<p>Install oil/water separators, sumps and dry adsorbents for areas where potential sources of residual fluids are stockpiled (e.g., automotive engine storage areas)</p> <p>The plan shall implement measures necessary to <i>minimize</i> contact of surface runoff with residual cutting fluids. The SWPPP shall document considerations of the following <i>BMPs</i> (or their equivalents):</p> <ul style="list-style-type: none"> • Store all turnings exposed to cutting fluids under some form of permanent or semi-permanent cover. <i>Stormwater discharges</i> from these areas are permitted provided the runoff is first treated by an oil/water separator or its equivalent. Procedures to collect, handle, and dispose or recycle residual fluids that may be present shall be identified in the plan • Establish dedicated containment areas for all turnings that have been exposed to cutting fluids. <i>Stormwater</i> runoff from these areas can be <i>discharged</i> provided: <ul style="list-style-type: none"> ○ The containment areas are constructed of either concrete, asphalt or other equivalent type of impermeable material; ○ There is a drainage collection system for runoff generated from containment areas; ○ There is a schedule to maintain the oil/water separator (or its equivalent); and ○ Procedures are identified and implemented for the proper disposal or recycling of collected residual fluids.
	<p style="text-align: center;">Scrap & Recyclable Waste Processing Areas</p>	<p>The SWPPP shall include <i>BMPs</i> to <i>minimize</i> surface runoff from coming in contact with scrap processing equipment. In the case of processing equipment that generate visible amounts of particulate residue (e.g., shredding facilities), the plan shall describe measures to <i>minimize</i> the contact of residual fluids and accumulated particulate matter with runoff (i.e., through good housekeeping, preventive maintenance,</p>

		<p>etc.). The SWPPP shall document considerations of the following <i>BMPs</i> (or their equivalents):</p> <ul style="list-style-type: none"> • Provide <i>stormwater</i> containment within a 30 foot perimeter of the following fixed equipment: shears, balers, shredders, grinders, screeners and conveyors; • Oil/water separators or sumps; • Catch basin filters or sand filters; • Use and maintenance of silt and/or other fencing around light material processing to prevent migration lightweight materials such as foam by wind and <i>stormwater</i> runoff. • using dry-absorbents or other cleanup practices to collect and dispose of or recycle spilled or leaking fluids or use mercury spill kits for spills from storage of mercury switches
N-4	Auto Shredders	<p>At minimum, the SWPPP shall document considerations of the following <i>BMPs</i> (or their equivalents):</p> <ul style="list-style-type: none"> • Use and maintenance of silt and/or other fencing around shredder fluff or other light material processing to prevent migration lightweight materials such as foam by wind and <i>stormwater</i> runoff. • The ground in the entire shredder and downstream area shall be covered by asphalt or concrete, and drainage shall be controlled • Ground surface must be cleaned/swept at the end of each shift to prevent dirt and debris from being tracked to other areas
N-5	Indoor Storage Areas	<p>The plan shall include <i>BMPs</i> to <i>minimize/eliminate</i> contact between residual liquids from waste materials stored indoors and surface runoff. The following Non-Structural <i>BMPs</i> must be implemented:</p> <ul style="list-style-type: none"> (i) Development and implementation of procedures for material handling (including labeling and marking); and (ii) Keep a sufficient supply of dry absorbent materials or a wet vacuum system to collect spilled or leaked materials. (iii) The use of mercury spill kits for spills from storage of mercury switches

		<p>The SWPPP must document decisions relating to consideration of the following Structural <i>BMPs</i>:</p> <ul style="list-style-type: none"> (i) An appropriate containment structure, such as trenches, curbing, gutters or other equivalent measures; and (ii) A drainage system, including appurtenances (e.g., pumps or ejectors, or manually operated valves), to handle <i>discharges</i> from diked or bermed areas. Drainage shall be <i>discharged</i> to an appropriate treatment facility, sanitary sewer system, or otherwise disposed of properly. <i>Discharges</i> from these areas may require coverage under a separate <i>SPDES</i> permit or industrial user permit under the pretreatment program
	<p>Truck & Rail Car Transfer Areas, Outdoor Stockpiles & Storage Areas</p>	<p>Required: Maintain sufficient supply of absorbent materials or a wet vacuum system to collect spills.</p> <p>The SWPPP must document decisions relating to consideration of the following Structural <i>BMPs</i>:</p> <ul style="list-style-type: none"> (i) Appropriate containment structures (e.g., dikes, berms, curbing, pits) to store the volume of the largest single tank, with sufficient extra capacity for precipitation; (ii) Drainage control and other diversionary structures; and (iii) For storage tanks, provide corrosion protection and/or leak detection systems

N-6	Vessel Breaking/Scraping Activities	<p>The following SWPPP special conditions have been established for facilities that are engaged in dismantling ships, marine salvaging, and marine wrecking ships for scrap.</p> <p>Scraping of vessels shall be accomplished ashore beyond the range of mean high tide, whenever practicable. If this activity must be conducted while a vessel is afloat or grounded in <i>State</i> waters, then the <i>owner or operator</i> must employ <i>BMPs</i> to <i>minimize</i> the amount of <i>pollutants</i> released</p> <p>The following <i>BMPs</i> shall be implemented during those periods when vessels (ships, barges, yachts, etc.) are brought to the facility's site for recycling, scrapping and storage prior to scrapping:</p> <ol style="list-style-type: none"> 1. Fixed or floating platforms sufficiently sized and constructed to catch and prevent scrap materials and <i>pollutants</i> from entering <i>waters of the State</i> (or equivalent measures approved by the <i>Department</i>) shall be used as work surfaces when working on or near the water surface. These platforms shall be cleaned as required to prevent <i>pollutants</i> from entering <i>State</i> waters and at the end of each work shift. All scrap metals and <i>pollutants</i> shall be collected in a manner to prevent releases (containerization is recommended). 2. There shall be no <i>discharge</i> of oil or oily wastewater at the facility. Drip pans and other protective devices shall be required for all oil and oily waste transfer operations to catch incidental spillage and drips from hose nozzles, hose racks, drums or barrels. Drip pans and other protective devices shall be inspected and maintained to prevent releases. Oil and oily waste must be disposed at a permitted facility and adequate documentation of off site disposition shall be retained for review by the board upon request. 3. During the storage/breaking/scrapping period, oil containment boom(s) shall be deployed either around the vessel being scrapped, or across the mouth of the facility's wet slip, to contain <i>pollutants</i> in the event of a spill. Booms must be inspected, maintained, and repaired as needed. Oil, grease and fuel spills shall be prevented from reaching <i>State</i> waters. Cleanup shall be carried out promptly after an oil, grease, and/or fuel spill is detected. 4. Paint and solvent spills shall be immediately cleaned up to prevent <i>pollutants</i> from reaching storm drains, deck drains, and <i>State</i> waters 5. Contaminated bilge and ballast water shall not be <i>discharged</i> to waters of the <i>State</i>. If it becomes necessary to dispose of contaminated bilge and ballast waters during a vessel breaking activity, the wastewater must be disposed at a permitted facility and adequate
-----	--	---

		documentation of off site disposition shall be retained for review by the board upon request.											
Spill & Leak Prevention	<p>The SWPPP shall include measures to <i>minimize stormwater</i> contamination at loading/unloading areas, and from equipment or container failures. The plan may refer to applicable portions of other existing plans such as SPCC plans required under 40 CFR Part 112</p> <ul style="list-style-type: none"> • Describe spill prevention and response measures to address areas that are potential sources of fluid leaks or spills. Include measures used for any release of mercury from switches, anti-lock brake systems, and switch storage areas • Provide for immediate containment and clean up of spills/leaks. If malfunctioning equipment is responsible for the spill/leak, repairs shall also be conducted as soon as possible • Specify cleanup procedures, including the use of dry absorbents. Where dry absorbent cleanup methods are used, an adequate supply of dry absorbent material shall be maintained on site. Used absorbent material shall be disposed of properly. • Place drip pans or equivalent measures under any leaking piece of stationary equipment until the leak is repaired. The drip pans shall be inspected for leaks and potential overflow and all liquids properly disposed of in accordance with RCRA requirements <p>The SWPPP shall document considerations of the following <i>BMPs</i> (or their equivalents):</p> <ul style="list-style-type: none"> • Store drums containing liquids, especially oil and lubricants, indoors; in a bermed area; in overpack containers or spill pallets; or in similar containment devices • Install overfill prevention devices on all fuel pumps or tanks • Install an alarm and/or pump shut off system on outdoor equipment with hydraulic reservoirs exceeding 150 gallons in order to prevent draining the tank contents in the event of a line break. Alternatively, the equipment may have a secondary containment system capable of containing the contents of the hydraulic reservoir plus adequate freeboard for precipitation. 												
Numeric Effluent Limitations	<p style="text-align: center;">Table VII N-1 Sector N – Numeric Effluent Limitations (Subsector N4 Only)</p> <table border="1" style="width: 100%; border-collapse: collapse;"> <thead> <tr> <th rowspan="2" style="width: 30%; text-align: center;">Parameter</th> <th colspan="2" style="text-align: center;">Effluent Limitations</th> </tr> <tr> <th style="text-align: center;">Daily Maximum</th> <th style="text-align: center;">30 Day - Average</th> </tr> </thead> <tbody> <tr> <td style="text-align: center;">Total Mercury*</td> <td style="text-align: center;">50 ng/L</td> <td></td> </tr> <tr> <td style="text-align: center;">PCBs</td> <td style="text-align: center;">200 ng/L per Aroclor**</td> <td></td> </tr> </tbody> </table> <p>*Mercury Analysis shall be by EPA Method 1631 ** Required for Aroclors 1016, 1221, 1232, 1242, 1248, 1254 and 1260. If 65 ng/L per Aroclor or more is detected, <i>owner or operator</i> shall make adjustments to their <i>BMPs</i></p>		Parameter	Effluent Limitations		Daily Maximum	30 Day - Average	Total Mercury*	50 ng/L		PCBs	200 ng/L per Aroclor**	
Parameter	Effluent Limitations												
	Daily Maximum	30 Day - Average											
Total Mercury*	50 ng/L												
PCBs	200 ng/L per Aroclor**												

Benchmarks	<p>Scrap recycling and waste recycling facilities; and facilities engaged in dismantling ships, marine salvaging, and marine wrecking ships for scrap are required to monitor their <i>stormwater discharges</i> for the <i>pollutants</i> of concern as follows:</p> <p><u>Subsector N-1</u>: Facilities engaged <i>only</i> in activities limited to the description of Sector N-1 are not required to complete <i>benchmark monitoring</i> and analysis</p> <p><u>Subsectors N-2, N-3, N-4, N-5 and N-6</u>: Facilities in these subsectors must complete the benchmark analysis in Table VII-N-2 below,</p> <p><u>Subsector N-4</u>: In addition to the parameters in Table-N-2, Subsector N-4 facilities must also complete benchmark analysis for the parameters in Table VII-N-3 for <i>outfalls</i> discharging <i>stormwater</i> from drainage areas where shredder operations and storage areas.</p>	
	Table VII N-2 Sector N - Benchmark Monitoring Requirement	
	Pollutants of Concern	Benchmark Monitoring Cut-off Concentration
	Scrap Recycling and Waste Recycling Facilities (nonsource-separated facilities only) (SIC 5093) and Facilities Engaged in Dismantling Ships, Marine Salvaging, and Marine Wrecking - Ships For Scrap (SIC 4499, limited to list)	
	Total Suspended Solids (TSS)	100 mg/L
	Chemical Oxygen Demand (COD)	120 mg/L
	Oil and Grease	15 mg/L
	Total Recoverable Aluminum	750 ug/L
	Total Recoverable Cadmium	1.8 ug/L
	Total Chromium	1.8 mg/L
	Total Recoverable Copper	12 ug/L
	Total Recoverable Iron	1 mg/L
	Total Recoverable Lead	69 ug/L
	Total Recoverable Zinc	110 ug/L
	Table VII N-3 Additional Subsector N4 – Benchmark Monitoring Requirements	
Pollutant of Concern	Benchmark Monitoring Cut-off Concentration	
Benzene	50 ug/L	
Ethylbenzene	50 ug/L	
Toluene	50 ug/L	
Xylene	50 ug/L	

Sector O – Steam Electric Generating Stations

Applicability	<p>The requirements listed under this section apply to <i>stormwater discharges associated with industrial activity</i> from steam electric power generating facilities using coal, natural gas, oil, nuclear energy, or other sources of energy to produce a steam source, including coal handling areas; <i>stormwater discharges</i> from coal pile runoff subject to numeric <i>effluent limitations</i> are eligible for coverage under this permit, but are subject to <i>effluent limitations</i> established by 40 CFR 423; and dual fuel co-generation facilities.</p>
Prohibitions Non -Stormwater discharges	<p><i>Stormwater discharges</i> not covered by this permit include: ancillary facilities (e.g., fleet centers, gas turbine stations, and substations) that are not contiguous to a steam electric power generating facility; and heat capture co-generation facilities.</p> <p>In addition to the general non-<i>stormwater</i> prohibition in Part I.C.1, non-<i>stormwater discharges</i> subject to <i>effluent limitation guidelines</i> are also not covered by this permit.</p>
SWPPP Requirements in addition to Part III	
Site Map	<p>The site map shall identify the locations of any of the following activities or sources that may be exposed to precipitation/surface runoff:</p> <ul style="list-style-type: none"> • Storage tanks, scrap yards, general refuse areas; • Short and long term storage of general materials (including, but not limited to: supplies, construction materials, plant equipment, oils, fuels, used and unused solvents, cleaning materials, paint, water treatment chemicals, fertilizer, and pesticides); • Landfills; • Construction sites; and • Stock pile areas (such as coal or limestone piles).
Additional Non-Numeric Effluent Limits	
Inspections	<p><u>Comprehensive site compliance evaluation</u> - As part of the evaluation, qualified facility personnel shall inspect the following areas on a monthly basis:</p> <ul style="list-style-type: none"> • Coal handling areas • Loading/unloading areas • Switchyards • Fueling areas • Bulk storage areas • Ash handling areas • Areas adjacent to disposal ponds and landfills • Maintenance areas • Liquid storage tanks; and, • Long term and short term material storage areas

Good Housekeeping Measures	
Fugitive Dust Emissions	<p>The SWPPP shall describe and provide for implementation of measures that prevent or <i>minimize</i> fugitive dust emissions from coal handling areas. The SWPPP shall document procedures to <i>minimize</i> off-site tracking of coal dust such as installing specially designed tires, or washing vehicles in a designated area before they leave the site, and controlling the wash water.</p>
Delivery Vehicles	<p>The SWPPP must describe and provide for implementation of measures that prevent or <i>minimize</i> contamination of <i>stormwater</i> runoff from delivery vehicles arriving on the plant site. At a minimum the SWPPP shall include:</p> <ul style="list-style-type: none"> • Procedures for the inspection of delivery vehicles arriving on the plant site, and ensure overall integrity of the body or container; and • Procedures to deal with leakage/spillage from vehicles or containers
Fuel Oil Unloading Areas	<p>The SWPPP must describe and provide for implementation of measures that prevent or <i>minimize</i> contamination of precipitation/surface runoff from fuel oil unloading areas. At a minimum, the SWPPP must document consideration of the following measures (or their equivalents):</p> <ul style="list-style-type: none"> • Use containment curbs in unloading areas; • Station personnel familiar with spill prevention and response procedures present during deliveries to ensure that any leaks/spills are immediately contained and cleaned up; and • Use spill and overflow protection (e.g., drip pans, drip diapers, and/or other containment devices placed beneath fuel oil connectors) to contain potential spillage during deliveries or from leaks at the connectors.
Chemical Loading & Unloading Areas	<p>The SWPPP must describe and provide for implementation of measures that prevent or <i>minimize</i> contamination of precipitation/surface runoff from Chemical loading and unloading areas. At a minimum, the SWPPP must document consideration of the following measures (or their equivalents):</p> <ul style="list-style-type: none"> • Use containment curbs in unloading areas; • Station personnel familiar with spill prevention and response procedures to ensure that any leaks/spills are immediately contained and cleaned up; and • Where practicable, load and unload in covered areas and store chemicals indoors.

<p style="text-align: center;">Miscellaneous loading/unloading areas</p>	<p>The SWPPP shall describe and provide for implementation of measures that prevent or <i>minimize</i> the contamination of <i>stormwater</i> runoff from loading and unloading areas.</p> <p>The SWPPP shall document considerations of the following <i>BMPs</i> (or their equivalents):</p> <ul style="list-style-type: none"> • Covering the loading area; • Grading, berming, or curbing around the loading area to divert run-on; • Locating the loading/unloading equipment and vehicles so that leaks are contained in existing containment and flow diversion systems
<p style="text-align: center;">Liquid Storage</p>	<p>The SWPPP shall describe and provide for implementation of measures that prevent or <i>minimize</i> contamination of <i>stormwater</i> runoff from aboveground liquid storage tanks. At a minimum the SWPPP must document consideration of the following measures (or their equivalents):</p> <ul style="list-style-type: none"> • Use of protective guards around tanks; • Use of containment curbs; • Use of spill and overflow protection; and • Use of dry cleanup methods.
<p style="text-align: center;">Large Bulk Storage Fuel Tanks</p>	<p>The SWPPP shall describe and provide for implementation of measures that prevent or <i>minimize</i> contamination of <i>stormwater</i> runoff from large bulk fuel storage tanks. At a minimum, the SWPPP must document consideration of containment berms (or their equivalent). The <i>owner or operator</i> shall also comply with applicable <i>State</i> and federal laws, including Spill Prevention Control and Countermeasures (SPCC).</p>
<p style="text-align: center;">Spill Reduction Measure</p>	<p>The SWPPP shall describe and provide for implementation of measures to reduce the potential for an oil/chemical spill, or reference the appropriate section of their SPCC plan. At a minimum, the structural integrity of all aboveground tanks, pipelines, pumps and other related equipment shall be visually inspected on a weekly basis. All repairs deemed necessary based on the findings of the inspections shall be completed immediately to reduce the incidence of spills and leaks occurring from such faulty equipment.</p>
<p style="text-align: center;">Oil bearing equipment in switchyards</p>	<p>The SWPPP shall describe and provide for implementation of measures to prevent or <i>minimize</i> contamination of surface runoff from oil bearing equipment in switchyard areas. The SWPPP shall document consideration of the use of level grades and gravel surfaces to retard flows and limit the spread of spills, and the collection of <i>stormwater</i> runoff in perimeter ditches.</p>

Residue Hauling Vehicles	All residue hauling vehicles shall be inspected for proper covering over the load, adequate gate sealing and overall integrity of the container body. Vehicles without load coverings or adequate gate sealing, or with leaking containers or beds must be repaired as soon as practicable.
Ash Loading Areas	The SWPPP shall describe and provide for implementation of procedures to reduce or control the tracking of ash/residue from ash loading areas. Where practicable, clear the ash building floor and immediately adjacent roadways of spillage, debris and excess water before departure of each loaded vehicle.
Landfills, Scrapyards, Surface Impoundments, General Refuse Sites	The plan must address and include appropriate <i>BMPs</i> for landfills, scrapyards, surface impoundments, non-compliant landfills and general refuse sites.
Vehicle Maintenance Areas	For vehicle maintenance activities performed on the plant site, the SWPPP shall specify the applicable <i>BMPs</i> outlined in Sector P.
Material Storage Areas	<p>The SWPPP shall describe and provide for implementation of measures that prevent or <i>minimize</i> contamination of <i>stormwater</i> runoff from material storage areas (including areas used for temporary storage of miscellaneous products, and construction materials stored in lay down areas). The SWPPP shall document considerations of the following <i>BMPs</i> (or their equivalents):</p> <ul style="list-style-type: none"> • Flat yard grades; • Runoff collection in graded swales or ditches; erosion protection measures at steep <i>outfall</i> sites (e.g., concrete chutes, riprap, stilling basins); • Covering lay down areas storing materials indoors; and • Covering materials temporarily with polyethylene, polyurethane, polypropylene, or hypalon. • <i>Minimize stormwater</i> run-on by constructing an enclosure or berming around the area.
Numeric Effluent Limitations	<i>Owner or operators with point sources</i> of coal pile runoff associated with steam electric power generation must monitor these <i>stormwater discharges</i> for the presence of TSS and for pH at least annually in accordance with Part IV.F.3.f (Table IV.3).

	Table VII-O-1 Sector O – Numeric Effluent Limitations		
	Parameter	Effluent Limitation	
		Daily Maximum	30-Day Average
	PCBs	200 ng/L per Aroclor*	
	* Required for Aroclors 1016, 1221, 1232, 1242, 1248, 1254 and 1260. If 65 ng/L per Aroclor or more is detected, <i>owner or operator</i> shall make adjustments to their <i>BMPs</i>		
Benchmarks	Steam electric power generating facilities are required to monitor their <i>stormwater discharges</i> for the <i>pollutant</i> of concern listed in Table VII-O-2.		
	Table VII-O-2 Sector O - Benchmark Monitoring Requirement		
	Pollutants of Concern	Benchmark Monitoring Cut-off Concentration	
	Steam Electric Generating Facilities (Industrial Activity Code "SE")		
	Oil & Grease	15 mg/L	
	Total Recoverable Iron	1 mg/L	

Sector P – Land Transportation and/or Warehousing

Applicability	<p>The requirements listed under this section apply to <i>stormwater discharges associated with industrial activity</i> from land transportation and/or warehousing facilities (generally identified by SIC Codes 4011, 4013, 4111-4173, 4212-4231, 4311 and 5171), that have vehicle and equipment maintenance shops (vehicle and equipment rehabilitation, mechanical repairs, painting, fueling and lubrication) and/or equipment cleaning operations. Transfer stations that have vehicle and equipment maintenance shops are covered under this sector in addition to the applicable Sector N subsector requirements.</p>
Prohibitions Non - Stormwater discharges	<p>The <i>discharge</i> of vehicle/equipment wash waters, including tank cleaning operations, are not authorized by this permit and must be covered under a separate <i>SPDES</i> permit or <i>discharged</i> to a sanitary sewer in accordance with applicable industrial pretreatment requirements.</p>
SWPPP Requirements in addition to Part III	
Site Map	<p>The site map shall identify the locations of any of the following activities or sources:</p> <ul style="list-style-type: none"> • Fueling stations; • Vehicle/equipment maintenance or cleaning areas; • Storage areas for vehicle/equipment with actual or potential fluid leaks; • Loading/unloading areas; • Areas where treatment, storage or disposal of wastes occur; liquid storage tanks; • Processing areas; • Storage areas; and • All monitoring areas
Summary of Potential Pollutant Sources	<p>The plan shall describe and assess the potential for the following to contribute <i>pollutants</i> to <i>stormwater discharges</i>:</p> <ul style="list-style-type: none"> • On-site waste storage or disposal; • Dirt/gravel parking areas for vehicles awaiting maintenance; and, • Fueling areas

Additional Non-Numeric Effluent Limits	
Inspections	<p>The following areas /activities shall be included in all inspections:</p> <ul style="list-style-type: none"> • Storage area for vehicles /equipment awaiting maintenance; • Fueling areas; • Indoor and outdoor vehicle/equipment maintenance areas; • Material storage areas; • Vehicle/equipment cleaning areas; and • Loading/unloading areas
Employee Training	<p>Employee training shall take place, at a minimum, annually (once per calendar year) and must address the following, as applicable:</p> <ul style="list-style-type: none"> • Used oil and spent solvent management; • Fueling procedures; • General good housekeeping practices; • Proper painting procedures; and • Used battery management
Good Housekeeping Measures	
Vehicle & Equipment Storage Areas	<p>The storage of vehicles and equipment awaiting maintenance with actual or potential fluid leaks must be confined to designated areas (delineated on the site map). The SWPPP shall document considerations of the following <i>BMPs</i> (or their equivalents):</p> <ul style="list-style-type: none"> • The use of drip pans under vehicles and equipment; • Indoor storage of vehicles and equipment; • Installation of berms or dikes; • Use of absorbents; • Roofing or covering storage areas; and • Cleaning pavement surface to remove oil and grease.
Fueling Areas	<p>The SWPPP shall describe and provide for implementation of measures that prevent or <i>minimize</i> contamination of the <i>stormwater</i> runoff from fueling areas. The SWPPP shall document consideration of the following measures (or their equivalents):</p> <ul style="list-style-type: none"> • Covering the fueling area; • Using spill/overflow protection and cleanup equipment; • Minimizing <i>stormwater</i> run-on/runoff to the fueling area; • Using dry cleanup methods; and • Treating and/or recycling collected <i>stormwater</i> runoff

<p style="text-align: center;">Material Storage Areas</p>	<p>Storage vessels of all materials (e.g., for used oil/oil filters, spent solvents, paint wastes, hydraulic fluids) must be maintained in good condition, so as to prevent contamination of <i>stormwater</i>, and plainly labeled (e.g., "used oil," "spent solvents," etc.). The SWPPP shall document considerations of the following <i>BMPs</i> (or their equivalents):</p> <ul style="list-style-type: none"> • Indoor storage of the materials; • Installation of berms/dikes around the areas, minimizing runoff of <i>stormwater</i> to the areas; • Using dry cleanup methods; and • Treating and/or recycling the collected <i>stormwater</i> runoff
<p style="text-align: center;">Vehicle & Equipment Cleaning Areas</p>	<p>The SWPPP shall describe and provide for implementation of measures that prevent or <i>minimize</i> contamination of <i>stormwater</i> runoff from all areas used for vehicle/equipment cleaning. The SWPPP shall document considerations of the following <i>BMPs</i> (or their equivalents):</p> <ul style="list-style-type: none"> • Performing all cleaning operations indoors; • Covering the cleaning operation; • Ensuring that all wash waters drain to a proper collection system (i.e., not the <i>stormwater</i> drainage system unless <i>SPDES</i> permitted); and, • Treating and/or recycling the collected <i>stormwater</i> runoff
<p style="text-align: center;">Vehicle & Equipment Maintenance Areas</p>	<p>The SWPPP shall describe and provide for implementation of measures that prevent or <i>minimize</i> contamination of the <i>stormwater</i> runoff from all areas used for vehicle/equipment maintenance. The SWPPP shall document considerations of the following <i>BMPs</i> (or their equivalents):</p> <ul style="list-style-type: none"> • Performing maintenance activities indoors; using drip pans; • Keeping an organized inventory of materials used in the shop; • Draining all parts of fluids prior to disposal; • Prohibiting wet clean up practices where the practices would result in the <i>discharge of pollutants</i> to <i>stormwater</i> drainage systems; • Using dry cleanup methods; • Treating and/or recycling collected <i>stormwater</i> runoff; and, • Minimizing runoff/runoff of <i>stormwater</i> to maintenance areas
<p style="text-align: center;">Locomotive Sanding (loading sand for traction) Areas</p>	<p>The SWPPP must describe measures that prevent or <i>minimize</i> contamination of the <i>stormwater</i> runoff from areas used for locomotive sanding. The SWPPP shall document considerations of the following <i>BMPs</i> (or their equivalents):</p> <ul style="list-style-type: none"> • Covering sanding areas; • Minimizing <i>stormwater</i> runoff/runoff; or • Appropriate sediment removal practices to <i>minimize</i> the off-site transport of sanding material by <i>stormwater</i>.

Numeric Effluent Limitations	No Numeric Effluent Limits specified for this sector.	
Benchmarks	Land transportation and/or warehousing facilities are required to monitor their <i>stormwater discharges</i> for the <i>pollutant</i> of concern listed in Table VII-P-1.	
	Table VII-P-1 Sector P - Benchmark Monitoring Requirement	
	<i>Pollutants of Concern</i> <i>Benchmark Monitoring Cut-off Concentration</i>	
	Land Transportation and /or Warehousing Facilities (SIC Codes 4011, 4013, 4111-4173, 4212-4231, 4311 and 5171)	
	Oil & Grease	15 mg/L
	Chemical Oxygen Demand (COD)	120 mg/L
	Benzene	50 ug/L
	Ethylbenzene	50 ug/L
Toluene	50 ug/L	
Xylene	50 ug/L	

Sector Q – Water Transportation

Applicability	<p>The requirements listed under this section apply to <i>stormwater discharges</i> associated with <i>industrial activity</i> from water transportation facilities (generally identified by SIC Major Group 44), that have vehicle (vessel) maintenance shops and/or equipment cleaning operations. The water transportation industry includes facilities engaged in foreign or domestic transport of freight or passengers in deep sea or inland waters; marine cargo handling operations; ferry operations; towing and tugboat services; and marinas, including: boat yards, storage and incidental repair; and yacht basins. The retail sale of fuel alone at marinas, without any other vessel maintenance or equipment cleaning operations, is not considered to be grounds for coverage under the storm water regulations.</p>
Prohibitions Non -Stormwater discharges	<p>In addition to the general non-<i>stormwater</i> prohibition in Part I.C.1, the following <i>discharges</i> not covered by this permit include, but are not limited to:</p> <ul style="list-style-type: none"> • Bilge and ballast water • Sanitary wastes • Pressure wash water • Cooling water originating from vessels.
SWPPP Requirements in addition to Part III	
Site Map	<p>The site map shall identify the locations where any of the following activities may be exposed to precipitation/surface runoff:</p> <ul style="list-style-type: none"> • Fueling; • Engine maintenance/repair; • Vessel maintenance/repair, pressure washing; • Painting; • Sanding; • Blasting; • Welding; • Metal fabrication; • Loading/unloading areas; • Locations used for the treatment, storage or disposal of wastes; • Liquid storage tanks; • Liquid storage areas (e.g., paint, solvents, resins); and, • Material storage areas (e.g., blasting media, aluminum, steel, scrap iron).
Summary of Potential Pollutant Sources	<p>The SWPPP shall describe the following additional sources and activities that have potential <i>pollutants</i> associated with them:</p> <ul style="list-style-type: none"> • Outdoor manufacturing or processing activities (i.e., welding, metal fabricating); • Significant dust or particulate generating processes (e.g., abrasive blasting, sanding, painting).

Additional Non-Numeric Effluent Limits	
Good Housekeeping Measures	
Pressures Washing Areas	<p><i>Discharge</i> of waste water from pressuring washing to remove marine growth from vessels must be permitted by a separate <i>SPDES</i> permit. Facilities that pressure wash vessels must include the following information in the SWPPP:</p> <ul style="list-style-type: none"> • Measures to collect or contain the <i>discharge</i> from the pressure washing area; • Method for the removal of the visible solids; • Methods of disposal of the collected solids; and, • Location where the <i>discharge</i> will be released
Blasting & Painting Areas	<p>The SWPPP shall describe and provide for implementation of standard operating practices for blasting and painting activities. The SWPPP shall document consideration of the prohibition of uncontained blasting/painting over open water, or the prohibition of blasting/painting during windy conditions which can render containment ineffective</p> <p>The SWPPP must describe and provide for implementation of measures to prevent spent abrasives, paint chips, and overspray from discharging into the receiving water or the storm sewer system. <i>Stormwater</i> conveyances shall be regularly cleaned to remove deposits of abrasive blasting debris and paint chips.</p> <p>The SWPPP shall document considerations of the following <i>BMPs</i> (or their equivalents):</p> <ul style="list-style-type: none"> • Containment of all blasting/painting activities • Use of hanging plastic barriers or tarpaulins during blasting or painting operations to contain debris • Other measures to prevent or <i>minimize</i> the <i>discharge</i> of contaminants
Material Storage Areas	<p>All containerized materials (fuels, paints, solvents, waste oil, antifreeze, batteries) must be plainly labeled and stored in a protected, secure location away from drains.</p> <p>The SWPPP must:</p> <ul style="list-style-type: none"> • Describe and provide for implementation of measures to prevent or <i>minimize</i> the contamination of precipitation/surface runoff from the storage areas. • Specify which materials are stored indoors and consider containment or enclosure for materials that are stored outdoors. • Document considerations regarding implementing an inventory control plan to limit the presence of potentially hazardous materials on-site. • Evaluate the storage and disposal of spent abrasive materials generated at the facility where abrasive blasting is performed.

<p style="text-align: center;">Engine Maintenance & Repair Areas</p>	<p>The SWPPP must describe and provide for implementation of measures to prevent or <i>minimize</i> contamination of precipitation/surface runoff from all areas used for engine maintenance and repair.</p> <p>The SWPPP shall document consideration of the following measures (or their equivalent):</p> <ul style="list-style-type: none"> • Performing all maintenance activities indoors; • Maintaining an organized inventory of materials used in the shop; • Draining all parts of fluids prior to disposal; • Prohibiting the practice of hosing down the shop floor; • Specify use of dry cleanup methods; and • Treating and/or recycling <i>stormwater</i> runoff collected from the maintenance area.
<p style="text-align: center;">Material Handling Areas</p>	<p>The SWPPP must describe and provide for implementation of measures to prevent or <i>minimize</i> contamination of precipitation/surface runoff from material handling operations and areas (e.g., fueling, paint and solvent mixing, disposal of process wastewater streams from vessels).</p> <p>The SWPPP shall document consideration of the following measures (or their equivalent):</p> <ul style="list-style-type: none"> • Covering fueling areas; • Using spill/overflow protection; • Mixing paints and solvents in a designated area (preferably indoors or under a shed); and • Minimizing run-on of <i>stormwater</i> to material handling areas
<p style="text-align: center;">Dry Dock Areas</p>	<p>The SWPPP must include the following:</p> <ul style="list-style-type: none"> • Routine maintenance and cleaning of the dry dock to <i>minimize</i> the potential for <i>pollutants</i> in the <i>stormwater</i> runoff. • Procedures for cleaning the accessible areas of the dry dock prior to flooding • Final cleanup after the vessel is removed and the dock is raised • Cleanup procedures for oil, grease, or fuel spills occurring on the dry dock • Sweep rather than hose off debris /spent blasting material from the accessible areas of the dry dock prior to flooding; • Keep absorbent materials and oil containment booms readily available to contain/cleanup any spills
<p style="text-align: center;">General Yard Area</p>	<p>The plan must include a schedule for routine yard maintenance and cleanup. Scrap metal, wood, plastic, miscellaneous trash, paper, glass, industrial scrap, insulation, welding rods, packaging, etc., must be routinely removed from the general yard area.</p>
<p style="text-align: center;">Inspections</p>	<p>The following areas shall be included in all monthly inspections:</p>

	<ul style="list-style-type: none"> • Pressure washing area; • Blasting, sanding, and painting areas; • Material storage areas; • Engine maintenance and repair areas; • Material handling areas; • Drydock area; and • General yard area <p>Comprehensive Site Inspection: The <i>owner or operator</i> shall conduct regularly scheduled evaluations at least once a year and address those areas contributing to a <i>stormwater discharge</i> associated with <i>industrial activity</i> (e.g., pressure washing area, blasting/sanding areas, painting areas, material storage areas, engine maintenance/repair areas, material handling areas, and drydock area). These sources shall be inspected for evidence of, or the potential for, <i>pollutants</i> entering the drainage system</p>
Employee Training	<p>Training shall address, at a minimum, the following activities (as applicable):</p> <ul style="list-style-type: none"> • Used oil management • Spent solvent management • Disposal of spent abrasives • Disposal of vessel wastewaters • Spill prevention and control • Fueling procedures • General good housekeeping practices • Painting and blasting procedures • Used battery management
Preventive Maintenance	<p>As part of the facility's preventive maintenance program, <i>stormwater</i> management devices shall be inspected and maintained in a timely manner (e.g., oil/water separators and sediment traps cleaned to ensure that spent abrasives, paint chips and solids are intercepted and retained prior to entering the storm drainage system). Facility equipment and systems shall also be inspected and tested to uncover conditions that could cause breakdowns or failures resulting in <i>discharges</i> of <i>pollutants</i> to surface waters</p>
Numeric Effluent Limitations	<p>No Numeric Effluent Limits specified for this sector.</p>
Benchmarks	<p>Water transportation facilities are required to monitor their <i>stormwater discharges</i> for the <i>pollutants</i> of concern listed in Table VII-Q-1.</p>

Table VII-Q-1	
Sector Q - Benchmark Monitoring Requirement	
<i>Pollutants of Concern</i>	<i>Benchmark Monitoring Cut-off Concentration</i>
Water Transportation Facilities (SIC 4412-4499)	
Total Recoverable Aluminum	750 ug/L
Total Recoverable Iron	1 mg/L
Total Recoverable Lead	69 ug/L
Total Recoverable Zinc	110 ug/L

Sector R – Ship & Boat Building or Repair Yards

Applicability	The requirements listed under this section apply to <i>stormwater discharges associated with industrial activity</i> from facilities engaged in ship and boat building and repairing (SIC Code 373). (According to the U.S. Coast Guard, a vessel 65 feet or greater in length is referred to as a ship and a vessel smaller than 65 feet is a boat.)
Prohibitions Non -Stormwater discharges	<p>In addition to the general non-<i>stormwater</i> prohibition in Part I.C.1, the following <i>discharges</i> not covered by this permit include, but are not limited to:</p> <ul style="list-style-type: none"> • Bilge and ballast water • Pressure wash water • Sanitary wastes • Cooling water originating from vessels
SWPPP Requirements in addition to Part III	
Site Map	<p>The site map shall identify the locations where any of the following activities may be exposed to precipitation/surface runoff:</p> <ul style="list-style-type: none"> • Fueling; • Engine maintenance/repair; • Vessel maintenance/repair; • Pressure washing; • Painting; • Sanding; • Blasting; • Welding; • Metal fabrication; • Loading/unloading areas; • Locations used for the treatment, storage or disposal of wastes; • Liquid storage tanks; • Liquid storage areas (e.g., paint, solvents, resins); and, • Material storage areas (e.g., blasting media, aluminum, steel, scrap iron).
Summary of Potential Pollutant Sources	<p>The SWPPP shall include a description of the following additional sources and activities that have potential <i>pollutants</i> associated with them (if applicable):</p> <ul style="list-style-type: none"> • Outdoor manufacturing/processing activities (e.g., welding, metal fabricating); • Significant dust/particulate generating processes (e.g., abrasive blasting, sanding, painting).

Additional Non-Numeric Effluent Limits	
Good Housekeeping Measures	
Pressure Washing	<p><i>Discharge</i> of waste water from pressuring washing to remove marine growth from vessels must be permitted by a separate <i>SPDES</i> permit. Facilities that pressure wash vessels must include the following information in the SWPPP:</p> <ul style="list-style-type: none"> • Measures to collect or contain the <i>discharge</i> from the pressure washing area; • Method for the removal of the visible solids; • Methods of disposal of the collected solids; and, • Location where the <i>discharge</i> will be released
Blasting & Painting Areas	<p>The SWPPP must:</p> <ul style="list-style-type: none"> • Describe and provide for the implementation of measures to prevent spent abrasives, paint chips and overspray from discharging into the receiving water body or the storm sewer system. • Include provisions to contain all blasting/painting activities to prevent the <i>discharge</i> of contaminants. Consider hanging plastic barriers or tarpaulins during blasting or painting operations to contain debris. • Include a schedule for regularly cleaning storm systems to remove deposits of abrasive blasting debris and paint chips, if applicable. • Describe and provide for implementation of standard operating practices for blasting and painting activities, such as the prohibition of uncontained blasting/painting over open water or the prohibition of blasting/painting during windy conditions that can render containment ineffective.
Material Storage Areas	<p>All containerized materials (fuels, paints, solvents, waste oil, antifreeze, batteries) must be plainly labeled and stored in a protected, secure location away from drains.</p> <p>The SWPPP must:</p> <ul style="list-style-type: none"> • Describe and provide for the implementation of measures to prevent or <i>minimize</i> contamination of precipitation/surface runoff from the storage areas. • Specify which materials are stored indoors and consider containment or enclosure for materials that are stored outdoors. • Document considerations regarding implementing an inventory control plan to limit the presence of potentially hazardous materials on-site. • Evaluate the storage and disposal of spent abrasive materials generated at the facility where abrasive blasting is performed

General Yard Area	<p>The plan must include a schedule for routine yard maintenance and cleanup. Scrap metal, wood, plastic, miscellaneous trash, paper, glass, industrial scrap, insulation, welding rods, packaging, etc., must be routinely removed from the general yard area.</p>
Engine Maintenance & Repair Areas	<p>The SWPPP must describe and provide for implementation of measures to prevent or <i>minimize</i> contamination of precipitation/surface runoff from all areas used for engine maintenance and repair.</p> <p>The SWPPP shall document considerations of the following <i>BMPs</i> (or their equivalence):</p> <ul style="list-style-type: none"> • Performing all maintenance activities indoors; • Maintaining an organized inventory of materials used in the shop; • Draining all parts of fluids prior to disposal; • Prohibiting the practice of hosing down the shop floor; • Specify use of dry cleanup methods • Treating and/or recycling <i>stormwater</i> runoff collected from the maintenance area.
Material Handling Areas	<p>The SWPPP must describe and provide for implementation of measures to prevent or <i>minimize</i> contamination of precipitation/surface runoff from material handling operations and areas (e.g., fueling, paint and solvent mixing, disposal of process wastewater streams from vessels).</p> <p>The SWPPP shall document considerations of the following <i>BMPs</i> (or their equivalents):</p> <ul style="list-style-type: none"> • Covering fueling areas; • Using spill/overflow protection; • Mixing paints and solvents in a designated area (preferably indoors or under a shed); • Minimizing run-on of <i>stormwater</i> to material handling areas
Dry dock Areas	<p>The SWPPP must describe procedures for the following:</p> <ul style="list-style-type: none"> • Routine maintenance and cleaning of the dry dock to <i>minimize</i> the potential for <i>pollutants</i> in the <i>stormwater</i> runoff. • Cleaning the accessible areas of the dry dock prior to flooding • Final cleanup after the vessels are removed and the dock is raised. • Cleanup of oil, grease, or fuel spills occurring on the dry dock. <ul style="list-style-type: none"> ○ Sweep rather than hose off debris /spent blasting material from the accessible areas of the dry dock prior to flooding ○ Keep absorbent materials and oil containment booms readily available to contain/cleanup any spills.
Inspections	<p>The following areas shall be included in all monthly inspections:</p> <ul style="list-style-type: none"> • Pressure washing areas;

	<ul style="list-style-type: none"> • Blasting, sanding, and painting areas • Material storage areas • Engine maintenance/repair areas • Material handling areas • Drydock area • General yard area. <p><u>Comprehensive site compliance evaluation</u> - The <i>permittee</i> shall conduct regularly scheduled evaluations at least once a year and address those areas contributing to a <i>stormwater discharge</i> associated with <i>industrial activity</i> (e.g., pressure washing area, blasting/sanding areas, painting areas, material storage areas, engine maintenance/repair areas, material handling areas, and drydock area). These sources shall be inspected for evidence of, or the potential for, <i>pollutants</i> entering the drainage system</p>
Employee Training	<p>Training shall address, at a minimum, the following activities (as applicable):</p> <ul style="list-style-type: none"> • Used oil management • Spent solvent management • Proper disposal of spent abrasives • Proper disposal of vessel wastewaters, spill prevention and control • Fueling procedures • General good housekeeping practices • Painting and blasting procedures • Used battery management.
Preventative Maintenance	<p>As part of the facility's preventative maintenance program, <i>stormwater</i> management devices shall be inspected and maintained in a timely manner (e.g., oil/water separators and sediment traps cleaned to ensure that spent abrasives, paint chips and solids are intercepted and retained prior to entering the storm drainage system). Facility equipment and systems shall also be inspected and tested to uncover conditions that could cause breakdowns or failures resulting in <i>discharges</i> of <i>pollutants</i> to surface waters.</p>
Numeric Effluent Limitations	<p>No Numeric Effluent Limits specified for this sector.</p>
Benchmarks	<p>No <i>Benchmark Monitoring</i> or reporting is required for this sector.</p>

Sector S – Air Transportation

Applicability	<p>The requirements listed under this section apply to <i>stormwater discharges associated with industrial activity</i> from air transportation facilities including</p> <ul style="list-style-type: none"> • air transportation (scheduled and non-scheduled); • air courier services; • airports; • flying fields (except those maintained by aviation clubs); • air terminal services including air traffic control (except government); • aircraft storage at airports; • aircraft upholstery repair; • airfreight handling at airports; • airport hangar rental; • airport leasing, if operating airport; • airport terminal services; • hangar operation; • airport, aircraft service and maintenance including aircraft cleaning and janitorial service; • aircraft servicing /repairing (except on a factory basis); • vehicle maintenance shops; • material handling facilities; • equipment clearing operations; and • airport/aircraft deicing and anti-icing. [Note: For the purpose of this section, the term "deicing" is defined as the process to remove frost, snow, or ice and "anti-icing" is the process which prevents the accumulation of frost, snow, or ice.] <p>Only those portions of the facility that are either involved in vehicle maintenance (including vehicle rehabilitation, mechanical repairs, painting, fueling, and lubrication), equipment cleaning operations, or deicing/anti-icing operations are addressed under this section.</p>
Prohibitions Non -Stormwater discharges	<p>In addition to the general non-<i>stormwater</i> prohibition in Paragraph I.D.1, the following <i>discharges</i> not covered by this permit include, but are not limited to:</p> <ul style="list-style-type: none"> • aircraft, ground vehicle, runway and equipment washwaters, and • dry weather <i>discharges</i> of deicing/anti-icing chemicals. <p>These <i>discharges</i> must be covered by a separate <i>SPDES</i> permit.</p>

SWPPP Requirements in addition to Part III

<p align="center">General</p>	<p>Air transportation facilities often have more than one operator who could <i>discharge stormwater</i> associated with <i>industrial activity</i>. For the purposes of this permit Owners or Operators include the airport authority and airport tenants., tenants Tenants of the airport facility include airline passenger or cargo companies, fixed based <i>owners or operators</i> and other parties who have contracts with the airport authority to conduct business operations on airport property and whose operations result in <i>stormwater discharges</i> associated with <i>industrial activity</i>.</p> <p>SWPPPs developed for areas of the facility occupied by tenants of the airport shall be integrated with the comprehensive SWPPP for the entire airport. As applicable, the comprehensive SWPPP must clearly specify the MSGP requirements to be complied with by the:</p> <ul style="list-style-type: none"> • Airport authority for itself; • Airport authority on behalf of its tenants; • Tenants for themselves <p>For each activity that an <i>owner or operator</i> conducts on behalf of another <i>owner or operator</i>, the SWPPP must describe a process for reporting results to the latter operator and for ensuring appropriate follow-up by all affected operators.</p>
<p align="center">Site Map</p>	<p>The site map shall identify where any of the following activities may be exposed to precipitation/surface runoff:</p> <ul style="list-style-type: none"> • Aircraft and runway deicing/anti-icing operations; • Fueling stations; • Aircraft, ground vehicle and equipment maintenance/cleaning areas; • Storage areas for aircraft, ground vehicles and equipment awaiting maintenance.
<p align="center">Summary of Potential Pollutant Sources</p>	<p>A narrative description of the potential <i>pollutant</i> sources from the following activities:</p> <ul style="list-style-type: none"> • aircraft, runway, ground vehicle and equipment maintenance and cleaning; • aircraft and runway deicing/anti-icing operations (including apron and centralized aircraft deicing/anti-icing stations, runways, taxiways and ramps). <p>Facilities that conduct deicing/anti-icing operations shall maintain a record of the types (including the Material Safety Data Sheets (MSDS)) and monthly quantities of deicing/anti-icing chemicals used, either as measured amounts, or in the absence of metering, as estimated amounts. This includes all deicing/anti-icing chemicals, not just glycols and urea (e.g., potassium acetate). Tenants and fixed-base operators who conduct deicing/anti-icing operations shall provide the above information to the airport authority for inclusion in the <i>stormwater</i> pollution prevention plan for the entire facility.</p>

Additional Non-Numeric Effluent Limits	
Good Housekeeping Measures	
Aircraft, ground vehicle and equipment maintenance areas	<p>The SWPPP must describe and provide for implementation of measures that prevent or <i>minimize</i> the contamination of <i>stormwater</i> runoff from all areas used for aircraft, ground vehicle and equipment maintenance (including the maintenance conducted on the terminal apron and in dedicated hangars).</p> <p>The SWPPP must document consideration of the following measures (or their equivalents)::</p> <ul style="list-style-type: none"> • Performing maintenance activities indoors; • Maintaining an organized inventory of materials used in the maintenance areas • Draining all parts of fluids prior to disposal • Preventing the practice of hosing down the apron or hangar floor • Using dry cleanup methods • Collecting the <i>stormwater</i> runoff from the maintenance area • Providing treatment or recycling
Aircraft, ground vehicle and equipment cleaning areas	<p>The SWPPP shall include provisions that ensure that cleaning of equipment is conducted in designated areas only and clearly identify these areas on the ground and delineate them on the site map.</p> <p>The plan must describe measures that will be implemented to prevent or <i>minimize</i> the contamination of the <i>stormwater</i> runoff from cleaning areas.</p>
Aircraft, ground vehicle and equipment storage areas	<p>The storage of aircraft, ground vehicles and equipment awaiting maintenance must be confined to designated areas (delineated on the site map).</p> <p>The SWPPP shall document consideration of the following <i>BMPs</i> (or their equivalents):</p> <ul style="list-style-type: none"> • Indoor storage of aircraft and ground vehicles • Use of drip pans for the collection of fluid leaks • Perimeter drains, dikes or berms surrounding storage areas.
Material storage areas	<p>The SWPPP must describe and provide for implementation of measures that prevent or <i>minimize</i> contamination of precipitation/runoff from storage areas. Storage vessels of all materials (e.g., used oils, hydraulic fluids, spent solvents, and waste aircraft fuel) must be maintained in good condition, so as to prevent or <i>minimize</i> contamination of <i>stormwater</i>, and plainly labeled (e.g., "used oil," "Contaminated Jet A," etc.).</p> <p>The SWPPP shall document consideration of the following <i>BMPs</i> (or their equivalents):</p> <ul style="list-style-type: none"> • Indoor storage of materials • Centralized storage areas for waste materials • Installation of berms/dikes around storage areas.

Airport Fuel System and Fueling Areas	<p>The SWPPP must describe and provide for implementation of measures that prevent or <i>minimize</i> the <i>discharge</i> of fuels to the storm sewer/surface waters resulting from fuel servicing activities or other operations conducted in support of the airport fuel system.</p> <p>The SWPPP shall document considerations of the following <i>BMPs</i> (or their equivalents):</p> <ul style="list-style-type: none"> • Implementing spill and overflow practices (e.g., placing absorptive materials beneath aircraft during fueling operations) • Using dry cleanup methods • Collecting the <i>stormwater</i> runoff
Source Reductions	
<p><i>Owners or operators</i> who conduct deicing/anti-icing operations shall consider alternatives to the use of urea and glycol-based deicing/anti-icing chemicals to reduce the aggregate amount of deicing/anti-icing chemicals used and/or lessen the environmental impact. Chemical options to replace ethylene glycol, propylene glycol and urea include: potassium acetate; magnesium acetate; calcium acetate; and anhydrous sodium acetate.</p>	
Runway Deicing Operations	<p><i>Owners or operators</i> shall evaluate present application rates to ensure against excessive over application by analyzing application rates and adjusting as necessary, consistent with considerations of flight safety.</p> <p>The SWPPP shall document considerations of the following <i>BMPs</i> (or their equivalents):</p> <ul style="list-style-type: none"> • Metered application of chemicals; • Prewetting dry chemical constituents prior to application; • Installation of runway ice detection systems; • Implementing anti-icing operations as a preventive measure against ice buildup; • Product substitution; • Heating sand
Aircraft deicing/anti icing operations	<p><i>Owners or operators</i> shall determine whether excessive application of deicing/anti-icing chemicals occurs, and adjust as necessary, consistent with considerations of flight safety. This evaluation should be carried out by the personnel most familiar with the particular aircraft and flight operations in question (versus an outside entity such as the airport authority). The use of alternative deicing/anti-icing agents, as well as containment measures for all applied chemicals, shall be considered.</p> <p>The SWPPP shall document considerations of the following <i>BMPs</i> (or their equivalents) for reducing deicing fluid:</p> <ul style="list-style-type: none"> • Forced-air deicing systems • Computer-controlled fixed-gantry systems • Infrared technology • Hot water • Varying glycol content to air temperature • Enclosed-basket deicing trucks

	<ul style="list-style-type: none"> • Mechanical methods • Solar radiation • Hangar storage • Aircraft covers • Thermal blankets for MD-80s and DC-9s • Ice-detection systems • Airport traffic flow strategies • Departure slot allocation systems
Management of runoff	<p>Where deicing/anti-icing operations occur, <i>owners or operators</i> shall describe and implement a program to control or manage contaminated runoff to <i>minimize</i> the amount of <i>pollutants</i> being <i>discharged</i> from the site.</p> <p>The SWPPP shall document consideration of the following <i>BMPs</i> (or their equivalents):</p> <ul style="list-style-type: none"> • Establish a dedicated deicing facility with a runoff collection/recovery system; • Use vacuum/collection trucks; • Store contaminated <i>stormwater</i>/deicing fluids in tanks and releasing controlled amounts to a publicly owned treatment works in accordance with pretreatment program requirements • Collect contaminated runoff in a wet pond for biochemical decomposition (be aware of attracting wildlife that may prove hazardous to flight operations) • Direct runoff into vegetative swales or other infiltration measures. • Recover deicing/anti-icing materials when these materials are applied during nonprecipitation events (e.g., covering storm sewer inlets, using booms, installing absorptive interceptors in the drains, etc.) to prevent these materials from later becoming a source of <i>stormwater</i> contamination. • Recycle used deicing fluid whenever possible
Inspections	<p>The inspection frequency shall be specified in the SWPPP. At a minimum, inspections shall be conducted once per month during deicing/anti-icing season (e.g., October through April for most airports). If deicing occurs before or after this period, the inspections shall be expanded to include all months during which deicing chemicals may be used.</p> <p>If significantly or deleteriously large quantities of deicing chemicals are being spilled or <i>discharged</i>, or if water quality impacts have been reported, the inspection frequency shall be increased to weekly until such time as the chemical spills/<i>discharges</i> or impacts are reduced to acceptable levels.</p>

Comprehensive site compliance inspection	<p>The annual site compliance evaluations shall be conducted by qualified facility personnel during periods of actual deicing operations, if possible. If not practicable during active deicing or if the weather is too inclement, the evaluations shall be conducted when deicing operations are likely to occur and the materials and equipment for deicing are in place.</p>												
Numeric Effluent Limitations	<p><u>Airfield Pavement Deicing</u> For both existing and new “primary airports” (as defined at 40 CFR 449.2) with 1,000 or more annual non-propeller aircraft departures that <i>discharge stormwater</i> from airfield pavement deicing activities, there shall be no <i>discharge</i> of airfield pavement deicers containing urea. To comply with this limitation, such airports must do one of the following: (1) certify annually on the annual report that you do not use pavement deicers containing urea, or (2) meet the effluent limitation in Table VII.S-1.</p> <p><u>Aircraft Deicing</u> Airports that are both “primary airports” (as defined at 40 CFR 449.2) and new sources (“new airports”) with 1,000 or more annual non-propeller aircraft departures must meet the applicable requirements for aircraft deicing at 40 CFR 449.11(a). <i>Discharges</i> of the collected aircraft deicing fluid directly to waters of the U.S. are not eligible for coverage under this permit.</p> <p><u>Monitoring, Reporting and Recordkeeping.</u> For new and existing airports subject to the effluent limitations above, you must comply with the applicable monitoring, reporting and recordkeeping requirements outlined in 40 CFR 449.20.</p> <p style="text-align: center;">Table VII-S-1. Sector S - Numeric Effluent Limitations</p> <table border="1" data-bbox="331 1031 1505 1312"> <thead> <tr> <th data-bbox="331 1031 894 1073">Industrial Activity</th> <th data-bbox="894 1031 1122 1073">Parameter</th> <th data-bbox="1122 1031 1505 1073">Effluent Limit</th> </tr> </thead> <tbody> <tr> <td data-bbox="331 1073 894 1312">Runoff containing urea from airfield pavement deicing at existing and new primary airports with 1,000 or more annual non-propeller aircraft departures.</td> <td data-bbox="894 1073 1122 1312">Ammonia as Nitrogen</td> <td data-bbox="1122 1073 1505 1312">14.7 mg/L daily maximum</td> </tr> </tbody> </table>			Industrial Activity	Parameter	Effluent Limit	Runoff containing urea from airfield pavement deicing at existing and new primary airports with 1,000 or more annual non-propeller aircraft departures.	Ammonia as Nitrogen	14.7 mg/L daily maximum				
Industrial Activity	Parameter	Effluent Limit											
Runoff containing urea from airfield pavement deicing at existing and new primary airports with 1,000 or more annual non-propeller aircraft departures.	Ammonia as Nitrogen	14.7 mg/L daily maximum											
Benchmarks	<p>Airports that use more than 100,000 gallons of glycol-based deicing/anti-icing chemicals and/or 100 tons or more of urea on an average annual basis shall sample their <i>stormwater discharges</i> for the parameters listed in Table VII-S-12. <u>Only those outfalls from the airport facility that collect runoff from areas where deicing/anti-icing activities occur must be monitored (SIC 4512-4581).</u></p> <p style="text-align: center;">Table VII-S-2 Sector S - Benchmark Monitoring Requirement</p> <table border="1" data-bbox="331 1583 1505 1843"> <thead> <tr> <th data-bbox="331 1583 764 1633">Pollutants of Concern</th> <th data-bbox="764 1583 1505 1633">Benchmark Monitoring Cut-off Concentration</th> </tr> </thead> <tbody> <tr> <td data-bbox="331 1633 764 1696">Biochemical Oxygen Demand (BOD5)</td> <td data-bbox="764 1633 1505 1696">30 mg/L</td> </tr> <tr> <td data-bbox="331 1696 764 1749">Chemical Oxygen Demand (COD)</td> <td data-bbox="764 1696 1505 1749">120 mg/L</td> </tr> <tr> <td data-bbox="331 1749 764 1791">Total Nitrogen (TN)*</td> <td data-bbox="764 1749 1505 1791">6 mg/L</td> </tr> <tr> <td data-bbox="331 1791 764 1843">pH</td> <td data-bbox="764 1791 1505 1843">within the range 6.0 to 9.0 s.u.</td> </tr> </tbody> </table> <p>* Total Nitrogen is calculated as the sum of ammonia, nitrate-nitrite and organic nitrogen</p>			Pollutants of Concern	Benchmark Monitoring Cut-off Concentration	Biochemical Oxygen Demand (BOD5)	30 mg/L	Chemical Oxygen Demand (COD)	120 mg/L	Total Nitrogen (TN)*	6 mg/L	pH	within the range 6.0 to 9.0 s.u.
Pollutants of Concern	Benchmark Monitoring Cut-off Concentration												
Biochemical Oxygen Demand (BOD5)	30 mg/L												
Chemical Oxygen Demand (COD)	120 mg/L												
Total Nitrogen (TN)*	6 mg/L												
pH	within the range 6.0 to 9.0 s.u.												

Sector T – Treatment Works

Applicability	<p>The requirements listed under this section apply to <i>stormwater discharges associated with industrial activity</i> from treatment works treating domestic sewage or any other sewage sludge or wastewater treatment device or system, used in the storage, treatment, recycling, and reclamation of municipal or domestic sewage, including lands dedicated to the disposal of sewage sludge that are located within the confines of the facility with a design flow of 1.0 MGD or more, or required to have an approved pretreatment program under 40 CFR 403 (Industrial Activity Code "TW"). Farm lands, domestic gardens or lands used for sludge management where sludge is beneficially reused and that are not physically located within the facility, or areas that are in compliance with Section 405 of the CWA are not required to have permit coverage.</p>
Prohibitions Non - Stormwater discharges	<p>In addition to the general non-<i>stormwater</i> prohibition in Part I.C.1, the following <i>discharges</i> not covered by this permit include, but are not limited to: sanitary and industrial wastewater; and equipment/vehicle wash waters</p>
SWPPP Requirements in addition to Part III	
Site Map	<p>The site map shall identify where any of the following may be exposed to precipitation/surface runoff:</p> <ul style="list-style-type: none"> • Grit, screenings and other solids handling, storage or disposal areas • Sludge drying beds • Dried sludge piles • Compost piles • Septage or hauled waste receiving station • Storage areas for process chemicals, petroleum products, solvents, fertilizers, herbicides and pesticides
Summary of Potential Pollutant Sources	<p>A description of the potential <i>pollutant</i> sources from the following activities, as applicable:</p> <ul style="list-style-type: none"> • Grit, screenings and other solids handling, storage or disposal areas • Sludge drying beds; dried sludge piles • Compost piles • Septage or hauled waste receiving station • Access roads/rail lines.

Additional Non-Numeric Effluent Limits									
BMPs	<p>The SWPPP shall document considerations of the following <i>BMPs</i> (or their equivalents):</p> <ul style="list-style-type: none"> • Routing <i>stormwater</i> to the treatment works • Covering exposed materials, including but not limited to the following: <ul style="list-style-type: none"> ○ Grit, screenings and other solids handling, storage or disposal areas ○ Sludge drying beds ○ Dried sludge piles ○ Compost piles ○ Septage or hauled waste receiving station. 								
Inspections	<p>The following areas shall be included in all inspections:</p> <ul style="list-style-type: none"> • Access roads/rail lines, grit, screenings and other solids handling, storage or disposal areas; • Sludge drying beds • Dried sludge piles • Compost piles • Septage or hauled waste receiving station areas 								
Employee Training	<p>Employee training must, at a minimum, address the following areas when applicable to a facility:</p> <ul style="list-style-type: none"> • Petroleum product management • Process chemical management • Spill prevention and control • Fueling procedures • General good housekeeping practices • Proper procedures for using fertilizers, herbicides and pesticides 								
Numeric Effluent Limitations	No Numeric Effluent Limits specified for this sector.								
Benchmarks	<p>Treatment works are required to monitor their <i>stormwater discharges</i> for the <i>pollutants</i> of concern listed in Table VII-T-1</p> <table border="1" style="width: 100%; border-collapse: collapse;"> <thead> <tr> <th colspan="2" style="text-align: center;">Table VII-T-1 Sector T - Benchmark Monitoring Requirement</th> </tr> <tr> <th style="text-align: left;">Pollutants of Concern</th> <th style="text-align: left;">Benchmark Monitoring Cut-off Concentration</th> </tr> </thead> <tbody> <tr> <td colspan="2">Treatment Works (Industrial Activity Code "TW")</td> </tr> <tr> <td>Chemical Oxygen Demand (COD)</td> <td style="text-align: center;">120 mg/L</td> </tr> </tbody> </table>	Table VII-T-1 Sector T - Benchmark Monitoring Requirement		Pollutants of Concern	Benchmark Monitoring Cut-off Concentration	Treatment Works (Industrial Activity Code "TW")		Chemical Oxygen Demand (COD)	120 mg/L
Table VII-T-1 Sector T - Benchmark Monitoring Requirement									
Pollutants of Concern	Benchmark Monitoring Cut-off Concentration								
Treatment Works (Industrial Activity Code "TW")									
Chemical Oxygen Demand (COD)	120 mg/L								

Sector U – Food & Kindred Products

Applicability	<p>The requirements listed under this section apply to <i>stormwater discharges associated with industrial activity</i> from food and kindred products processing facilities (commonly identified by SIC Code 20), including:</p> <ul style="list-style-type: none"> • Meat products • Dairy products • Canned, frozen and preserved fruits, vegetables, and food specialties • Grain mill products • Bakery products; • Sugar and confectionery products; • Fats and oils • Beverages • Miscellaneous food preparations and kindred products and tobacco products manufacturing (SIC Code 21).
Prohibitions Non -Stormwater discharges	<p>In addition to the general non-<i>stormwater</i> prohibition in Paragraph I.D.1, the following <i>discharges</i> not covered by this permit include, but are not limited to:</p> <ul style="list-style-type: none"> • Boiler blow down • Cooling tower overflow and blow down • Ammonia refrigeration purging • Vehicle washing/clean-out operations
SWPPP Requirements in addition to Part III	
Site Map	<p>The site map shall identify the locations of the following activities if they are exposed to precipitation/surface runoff:</p> <ul style="list-style-type: none"> • Vents/stacks from cooking, drying, and similar operations • Dry product vacuum transfer lines • Animal holding pens • Spoiled product • Broken product container storage areas
Summary of Potential Pollutant Sources	<p>In addition to food and kindred products processing-related industrial activities, the plan must also describe application and storage of pest control chemicals (e.g., rodenticides, insecticides, fungicides, etc.) used on plant grounds.</p>

Additional Non-Numeric Effluent Limits		
Inspections	<p>At a minimum, the following areas, where the potential for exposure to <i>stormwater</i> exists, must be inspected:</p> <ul style="list-style-type: none"> • Loading and unloading areas for all significant materials • Storage areas, including associated containment areas • Waste management units • Vents and stacks emanating from industrial activities • Spoiled product and broken product container holding areas • Animal holding pens • Staging areas • Air pollution control equipment 	
Employee Training	The employee training program must also address pest control.	
Numeric Effluent Limitations	No Numeric Effluent Limits specified for this sector.	
Benchmarks	Grain mills and fats and oils products facilities are required to monitor their <i>stormwater discharges</i> for the <i>pollutants</i> of concern listed in Table VII-U-1.	
	Table VII-U-1 Sector U - Benchmark Monitoring Requirement	
	Pollutants of Concern Benchmark Monitoring Cut-off Concentration	
	Grain Mill Products (SIC 2041-2048)	
	Total Suspended Solids (TSS)	100 mg/L
	Total Nitrogen (TN)	6 mg/L
	Total Phosphorus (TP)	2 mg/L
	Fats and Oils Products (SIC 2074-2079)	
	Total Suspended Solids (TSS)	100 mg/L
	Biochemical Oxygen Demand (BOD5)	30 mg/L
	Chemical Oxygen Demand (COD)	120 mg/L
	Total Nitrogen (TN)*	6 mg/L
	Total Phosphorus (TP)	2 mg/L
	* Total Nitrogen is calculated as the sum of ammonia, nitrate-nitrite and organic nitrogen.	

Sector V – Textile Mills, Apparel & Other Fabric Products

Applicability	<p>The requirements listed under this section apply to <i>stormwater discharges associated with industrial activity</i> from textile mills, apparel and other fabric product manufacturing, generally described by SIC 22 and 23. Facilities in this sector are primarily engaged in the following activities:</p> <ul style="list-style-type: none"> • Textile mill products, of and regarding facilities and establishments engaged in the preparation of fiber and subsequent manufacturing of yarn, thread, braids, twine, and cordage, • Manufacturing of broad woven fabrics, narrow woven fabrics, knit fabrics, and carpets and rugs from yarn • Processes involved in the dyeing and finishing of fibers, yarn fabrics, and knit apparel • Integrated manufacturing of knit apparel and other finished articles of yarn • Manufacturing of felt goods (wool), lace goods, nonwoven fabrics , miscellaneous textiles, and other apparel products. <p>This section also covers facilities engaged in manufacturing finished leather and artificial leather products (SIC 31, except 3111).</p>
Prohibitions Non -Stormwater discharges	<p>In addition to the general non-<i>stormwater</i> prohibition in Paragraph I.D.1, the following <i>discharges</i> not covered by this permit and must be covered by a separate <i>SPDES</i> Permit include, but are not limited to:</p> <ul style="list-style-type: none"> • <i>Discharges</i> of wastewater (e.g., wastewater as a result of wet processing or from any processes relating to the production process) • Reused/recycled water • Waters used in cooling towers
SWPPP Requirements in addition to Part III	
Summary of Potential Pollutant Sources	<p>A description of the potential <i>pollutant</i> sources from industry-specific <i>significant materials</i> and industrial activities (e.g., backwinding, beaming, bleaching, backing, bonding carbonizing, carding, cut and sew operations, desizing, drawing, dyeing, flocking, fulling, knitting, mercerizing, opening, packing, plying, scouring, slashing, spinning, synthetic-felt processing, textile waste processing, tufting, turning, weaving, web forming, winging, yarn spinning, and yarn texturing.)</p>

Additional Non-Numeric Effluent Limits	
Material storage areas	<p>All containerized materials (fuels, petroleum products, solvents, dyes, etc.) must be clearly labeled and stored in a protected area, away from drains.</p> <p>The SWPPP must document considerations of the following <i>BMPs</i> (or their equivalents):</p> <ul style="list-style-type: none"> • Describe and provide for implementation of measures that prevent or <i>minimize</i> contamination of <i>stormwater</i> runoff from such storage areas. • Provide for containment or enclosure of materials that are stored outdoors. • Develop an inventory control plan to prevent excessive purchasing of potentially hazardous substances. • Ensure that empty chemical drums/containers are clean <ul style="list-style-type: none"> ○ Triple-rinsing shall be considered ○ Residuals are not subject to contact with precipitation/runoff. ○ Proper collection and storage of washwater from drum cleanings
Material handling areas	<p>The SWPPP must describe and provide for implementation of measures that prevent or <i>minimize</i> contamination of the <i>stormwater</i> runoff from materials handling operations and areas.</p> <p>The SWPPP must document considerations of the following <i>BMPs</i> (or their equivalence):</p> <ul style="list-style-type: none"> • Use of spill/overflow protection • Covering fueling areas • Covering and enclosing areas where the transfer of materials may occur. • Replacement or repair of leaking connections, valves, transfer lines and pipes that may carry chemicals, dyes, or wastewater, where applicable.
Fueling areas	<p>The SWPPP must describe and include provisions to implement measures that prevent or <i>minimize</i> contamination of the <i>stormwater</i> runoff from fueling areas.</p> <p>The SWPPP shall document considerations of the following <i>BMPs</i> (or their equivalents):</p> <ul style="list-style-type: none"> • Covering the fueling area • Using spill and overflow protection • Minimizing runoff of <i>stormwater</i> to the fueling areas • Using dry cleanup methods • Treating and/or recycling <i>stormwater</i> runoff collected from the fueling area
Inspections	<p>Inspections shall be conducted at least monthly, and shall include the following activities and areas (at a minimum):</p> <ul style="list-style-type: none"> • Transfer and transmission lines; • Spill prevention; • Good housekeeping practices;

	<ul style="list-style-type: none"> • Management of process waste products; and • All structural and nonstructural management practices.
Aboveground storage tank areas	<p>The SWPPP must describe and provide for implementation of measures that prevent or <i>minimize</i> contamination of the <i>stormwater</i> runoff from aboveground storage tank areas, including the associated piping and valves.</p> <p>The SWPPP shall document considerations of the following <i>BMPs</i> (or their equivalents):</p> <ul style="list-style-type: none"> • Regular cleanup of these areas • Preparation of a spill prevention control and countermeasure program • Spill and overflow protection • Minimizing run-on of <i>stormwater</i> from adjacent areas • Restricting access to the area • Insertion of filters in adjacent catch basins • Absorbent booms in unbermed fueling areas • Use of dry cleanup methods • Permanently sealing drains within critical areas that may <i>discharge</i> to a storm drain.
Employee Training	<p>Employee training must, at a minimum address, the following areas when applicable to a facility:</p> <ul style="list-style-type: none"> • Use of reused/recycled waters; • Solvents management; • Proper disposal of dyes; • Proper disposal of petroleum products and spent lubricants; • Spill prevention and control; • Fueling procedures; and • General good housekeeping practices.
Comprehensive Site Inspection	<p>Regularly scheduled evaluations shall be conducted at least once a year and address those areas contributing to a <i>stormwater discharge</i> associated with <i>industrial activity</i>. Inspections shall look for evidence of, or the potential for, <i>pollutants</i> entering the drainage system from the following areas, as appropriate: storage tank areas; waste disposal and storage areas; dumpsters and open containers stored outside; materials storage areas; engine maintenance and repair areas; material handling areas and loading dock areas.</p>
Numeric Effluent Limitations	<p>No Numeric Effluent Limits specified for this sector.</p>
Benchmark	<p>No <i>Benchmark Monitoring</i> or reporting is required for this sector.</p>

Sector W – Furniture & Fixtures

Applicability	<p>The requirements listed under this section apply to <i>stormwater discharges associated with industrial activity</i> from facilities involved in the manufacturing of:</p> <ul style="list-style-type: none"> • Wood kitchen cabinets (generally described by SIC Code 2434) • Household furniture (SIC 251) • Office furniture (SIC 252) • Public buildings and related furniture (SIC 253) • Partitions, shelving, lockers, and office and store fixtures (SIC 254) • Miscellaneous furniture and fixtures (SIC 259).
SWPPP Requirements in addition to Part III	
Site Map	<p>The site map shall identify where any of the following may be exposed to precipitation/surface runoff:</p> <ul style="list-style-type: none"> • Material storage areas (including tanks or other vessels used for liquid or waste storage) • Outdoor material processing areas • Areas where wastes are treated, stored or disposed • Access roads • Rail spurs.
Additional Non-Numeric Effluent Limits	
Numeric Effluent Limitations	<p>No Numeric Effluent Limits specified for this sector.</p>
Benchmarks	<p>No <i>Benchmark Monitoring</i> or reporting is required for this sector.</p>

Sector X – Printing & Publishing

Applicability	<p>The requirements listed under this section apply to <i>stormwater discharges associated with industrial activity</i> from printing and publishing facilities (generally classified under SIC Major Group 27) including the following:</p> <ul style="list-style-type: none"> • Book printing • Commercial printing and lithographics • Plate making and related services • Commercial printing • Commercial printing not elsewhere classified.
SWPPP Requirements in addition to Part III	
Site Map	<p>The site map shall identify where any of the following may be exposed to precipitation/surface runoff:</p> <ul style="list-style-type: none"> • Aboveground storage tanks • Drums and barrels permanently stored outside.
Summary of Potential Pollutant Sources	<p>The plan shall include a description of the following additional sources and activities that have potential <i>pollutants</i> associated with them, as applicable:</p> <ul style="list-style-type: none"> • Loading and unloading operations • Outdoor storage activities • Significant dust or particulate generating processes • On-site waste disposal practices (e.g., blanket wash). <p>The <i>pollutant</i> or <i>pollutant</i> parameter associated with each <i>pollutant</i> source shall be identified (e.g., oil and grease, scrap metal, etc.).</p>
Employee Training	<p>Employee training must, at a minimum, address the following areas when applicable to a facility:</p> <ul style="list-style-type: none"> • Spent solvent management • Spill prevention and control • Used oil management • Fueling procedures • General good housekeeping practices

Additional Non-Numeric Effluent Limits	
Good Housekeeping Measures	
Material storage areas	<p>All containerized materials (skids, pallets, solvents, bulk inks, and hazardous waste, empty drums, portable/mobile containers of plant debris, wood crates, steel racks, fuel oil, etc) must be clearly labeled and stored in a protected area, away from drains.</p> <p>The SWPPP shall document considerations of the following <i>BMPs</i> (or their equivalents):</p> <ul style="list-style-type: none"> • Describe and provide for implementation of measures that prevent or <i>minimize</i> contamination of <i>stormwater</i> runoff from such storage areas • Provide for containment or enclosure for those materials that are stored outdoors. • Develop an inventory control plan to prevent excessive purchasing of potentially hazardous substances.
Material handling areas	<p>The SWPPP must describe and include provisions to implement measures that prevent or <i>minimize</i> contamination of the <i>stormwater</i> runoff from materials handling operations and areas (e.g. blanket wash, mixing solvents, loading & unloading materials).</p> <p>The SWPPP shall document considerations of the following <i>BMPs</i> (or their equivalents):</p> <ul style="list-style-type: none"> • Use of spill/overflow protection • Covering fueling areas • Covering and enclosing areas where the transfer of materials may occur. • Replacement or repair of leaking connections, valves, transfer lines and pipes that may carry chemicals, dyes, or wastewater, where applicable.
Fueling areas	<p>The SWPPP must describe and include provisions to implement measures that prevent or <i>minimize</i> contamination of the <i>stormwater</i> runoff from fueling areas.</p> <p>The SWPPP shall document considerations of the following <i>BMPs</i> (or their equivalents):</p> <ul style="list-style-type: none"> • Covering the fueling area • Using spill and overflow protection • Minimizing runoff of <i>stormwater</i> to the fueling areas • Using dry cleanup methods • Treating and/or recycling <i>stormwater</i> runoff collected from the fueling area.

<p style="text-align: center;">Aboveground storage tank areas</p>	<p>The SWPPP must describe and include provisions to implement measures that prevent or <i>minimize</i> contamination of the <i>stormwater</i> runoff from aboveground storage tank areas, including the associated piping and valves.</p> <p>The SWPPP shall document considerations of the following <i>BMPs</i> (or their equivalents):</p> <ul style="list-style-type: none"> • Regular cleanup of these areas • Preparation of a spill prevention control and countermeasure program • Spill and overflow protection • Minimizing run-on of <i>stormwater</i> from adjacent areas • Restricting access to the area • Insertion of filters in adjacent catch basins • Absorbent booms in unbermed fueling areas • Use of dry cleanup methods • Permanently sealing drains within critical areas that may <i>discharge</i> to a storm drain.
<p style="text-align: center;">Numeric Effluent Limitations</p>	<p>No <i>Numeric Effluent Limits</i> specified for this sector.</p>
<p style="text-align: center;">Benchmarks</p>	<p>No <i>Benchmark Monitoring</i> or reporting is required for this sector.</p>

Sector Y – Rubber, Plastics & Miscellaneous Manufacturing Industries

Applicability	The requirements listed under this section apply to <i>stormwater discharges associated with industrial activity</i> from rubber and miscellaneous plastic products manufacturing facilities (SIC Major Group 30) and miscellaneous manufacturing industries, except jewelry, silverware, and plated ware (SIC Major Group 39, except 391).
SWPPP Requirements in addition to Part III	
Site Map	The site map shall identify where any of the following may be exposed to precipitation/surface runoff: <ul style="list-style-type: none"> • Aboveground storage tanks • Drums and barrels permanently stored outside.
Summary of Potential Pollutant Sources	The <i>owner or operator</i> shall review the use of zinc at the facility and the possible pathways through which zinc may be <i>discharged</i> in <i>stormwater</i> runoff.
Plastic Products Manufacturers	The SWPPP shall describe and provide for implementation of specific controls to <i>minimize</i> the <i>discharge</i> of plastic resin pellets, powders, flakes, additives, regrind, scrap, waste and recycling in <i>stormwater discharges</i> . The SWPPP shall document considerations of the following <i>BMPs</i> (or their equivalents): <ul style="list-style-type: none"> • Minimizing spills • Cleaning up spills promptly and thoroughly • Sweeping thoroughly • Pellet capturing • Employee education • Disposal precautions
Additional Non-Numeric Effluent Limits	
Rubber Manufacturers	The SWPPP shall describe and provide for implementation of specific controls to <i>minimize</i> the <i>discharge</i> of zinc in <i>stormwater discharges</i> from the facility. Some general <i>BMP</i> options to consider include: <ul style="list-style-type: none"> • Using chemicals that are purchased in pre-weighed, sealed polyethylene bags; • Storing materials that are in use in sealable containers

	<ul style="list-style-type: none"> • Ensuring an airspace between the container and the cover to <i>minimize</i> "puffing" losses when the container is opened • Using automatic dispensing and weighing equipment. <p>The SWPPP shall document considerations of the following <i>BMPs</i> (or their equivalents): for the following possible sources of zinc:</p>
<p>Inadequate housekeeping -</p>	<p>Evaluate the handling and storage of zinc bags at their facilities and document the consideration for the following <i>BMP</i> options:</p> <ul style="list-style-type: none"> • Employee training regarding the handling/storage of zinc bags • Indoor storage of zinc bags • Cleanup of zinc spills without washing the zinc into the storm drain • Use of 2,500-pound sacks of zinc rather than 50- to 100-pound sacks.
<p>Dumpsters</p>	<p>The SWPPP shall document considerations relating to the following <i>BMPs</i> to <i>minimize discharges</i> of zinc from dumpsters:</p> <ul style="list-style-type: none"> • Provide a cover for the dumpster • Move the dumpster to an indoor location • Provide a lining for the dumpster*. <p>* If a liner is used in an uncovered dumpster, the SWPPP must describe the measures implemented to either prevent the <i>discharge</i> of contaminated <i>stormwater</i> from the containers, or the containers should be subject to screening and monitoring required in Part IV.F.1.</p>
<p>Malfunctioning dust collectors or baghouses</p>	<p>Evaluate dust collectors/baghouses as possible sources in zinc in <i>stormwater</i> runoff. Improperly operating dust collectors/baghouses shall be replaced or repaired as appropriate.</p>
<p>Grinding operations</p>	<p>Evaluate dust generation from rubber grinding operations at their facility and, as appropriate, install a dust collection system.</p>
<p>Zinc stearate coating operations</p>	<p>Appropriate measures to prevent or clean up drips /spills of zinc stearate slurry that may be released to the storm drain. Alternate compounds to zinc stearate shall also be considered.</p>

Numeric Effluent Limits	No Numeric Effluent Limits specified for this sector.	
Benchmarks	Rubber product manufacturing facilities are required to monitor their <i>stormwater discharges</i> for the <i>pollutants</i> of concern listed in Table VII-Y-1.	
	Sector VII-Y-1 Benchmark Monitoring Requirement	
	<i>Pollutants of Concern</i>	<i>Benchmark Monitoring Cut-off Concentration</i>
	Tires and Inner Tubes; Rubber Footwear; Gaskets, Packing and Sealing Devices; Rubber Hose and Belting; and Fabricated Rubber Products Not Elsewhere Classified (SIC 3011-3069).	
	Total Recoverable Zinc	110 ug/L

Sector Z – Leather Tanning and Finishing

Applicability	<p>The requirements listed under this section apply to <i>stormwater discharges associated with industrial activity</i> from leather tanning, currying and finishing (commonly identified by SIC Code 3111).</p>
SWPPP Requirements in addition to Part III	
Site Map	<p>The site map shall identify where any of the following may be exposed to precipitation/surface runoff:</p> <ul style="list-style-type: none"> • Processing and storage areas of the beamhouse, tanyard, retan-wet finishing and dry finishing operation • Haul roads • Access roads • Rail spurs.
Summary of Potential Pollutant Sources	<p>A description of potential <i>pollutant</i> sources including (as appropriate):</p> <ul style="list-style-type: none"> • Temporary or permanent storage of fresh and brine cured hides • Chemical drums, bags, containers and aboveground tanks • Leather dust, scraps, trimmings and shavings • Spent solvents • Extraneous hide substances and hair • Empty chemical containers and bags • Floor sweepings/washings • Refuse and waste piles and sludge • Significant dust/particulate generating processes (e.g., buffing).

Additional Non-Numeric Effluent Limits		
Good Housekeeping Measures	Storage for Raw, Semi-Processed or Finished Tannery By-Products	<p>Pallets/bales of raw, semi processed or finished tannery by-products (e.g., splits, trimmings, shavings, etc.) shall be stored indoors or protected by polyethylene wrapping, tarpaulins, roofed storage area or other suitable means.</p> <p>Materials shall be placed on an impermeable surface, the area should be enclosed or bermed or other equivalent measures should be employed to prevent runoff/runoff of <i>stormwater</i></p>
	Material Storage Areas	<p>Label storage units of all materials (e.g., specific chemicals, hazardous materials, spent solvents, waste materials).</p> <p>Describe and implement measures that prevent or <i>minimize</i> contact with <i>stormwater</i>.</p>
	Buffing & Shaving Areas	<p>The SWPPP shall describe and provide for implementation of measures that prevent or <i>minimize</i> contamination of the <i>stormwater</i> runoff with leather dust from buffing/shaving areas. The SWPPP shall document considerations for dust collection enclosures, preventive inspection/maintenance programs or other appropriate preventive measures.</p>
	Receiving, Unloading & Storage Areas	<p>The SWPPP shall describe and provide for implementation of measures that prevent or <i>minimize</i> contamination of the <i>stormwater</i> runoff from receiving, unloading, and storage areas. The SWPPP shall document considerations of the following <i>BMPs</i> (or their equivalents) for exposed receiving, unloading and storage areas:</p> <ul style="list-style-type: none"> • Hides and chemical supplies protected by a suitable cover • Diversion of drainage to the process sewer • Grade berming/curbing area to prevent runoff of <i>stormwater</i>.
	Outdoor Storage of Contaminated Equipment	<p>The SWPPP shall describe and provide for implementation of measures that prevent or <i>minimize</i> contact of <i>stormwater</i> with contaminated equipment. The SWPPP shall document considerations of the following <i>BMPs</i> (or their equivalents) :</p> <ul style="list-style-type: none"> • Equipment protected by suitable cover • Diversion of drainage to the process sewer • Thorough cleaning prior to storage.

<p style="text-align: center;">Good Housekeeping Measures (Continued)</p>	<p style="text-align: center;">Waste Management</p>	<p>Describe and implement measures that prevent or <i>minimize</i> contamination of the <i>stormwater</i> runoff from waste storage areas. The SWPPP shall document considerations of the following <i>BMPs</i> (or their equivalents) :</p> <ul style="list-style-type: none"> • Inspection/maintenance programs for leaking containers or spills • Cover dumpsters • Move waste management activities indoors • Cover waste piles with temporary covering material such as tarpaulins or polyethylene • <i>Minimize stormwater</i> runoff by enclosing the area or building berms around the area.
<p style="text-align: center;">Numeric Effluent Limits</p>	<p>No Numeric Effluent Limits specified for this sector.</p>	
<p style="text-align: center;">Benchmarks</p>	<p>Leather tanning and finishing facilities are required to monitor their <i>stormwater discharges</i> for the <i>pollutants</i> of concern listed in Table VII-Z-1.</p>	
<p>Sector VII-Z-1 Benchmark Monitoring Requirement</p>		
<p><i>Pollutants of Concern</i></p>		<p><i>Benchmark Monitoring Cut-off Concentration</i></p>
<p>Leather Tanning and Finishing (SIC 3111)</p>		
<p>Total Nitrogen (TN)*</p>	<p>6 mg/L</p>	
<p>Total Recoverable Chromium</p>	<p>1.8 mg/L</p>	
<p>* Total Nitrogen is calculated as the sum of ammonia, nitrate-nitrite and organic nitrogen</p>		

Sector AA - Fabricated Metal Products

Applicability	The requirements listed under this section apply to <i>stormwater discharges associated with industrial activity</i> from the fabricated metals industry (except for electrical related industries); fabricated metal products (except machinery and transportation equipment); and jewelry, silverware, and plated ware
SWPPP Requirements in addition to Part III	
Site Map	<p>The site map shall identify where any of the following may be exposed to precipitation/surface runoff:</p> <ul style="list-style-type: none"> • Raw metal storage areas • Finished metal storage areas • Scrap disposal collection sites • Equipment storage areas • Retention and detention basins • Temporary/permanent diversion dikes or berms • Right of way or perimeter diversion devices • Sediment traps/barriers • Processing areas including outside painting areas • Wood preparation • Recycling • Raw material storage.
Summary of Potential Pollutant Sources	<p>A description of the potential <i>pollutant</i> sources from the following activities:</p> <ul style="list-style-type: none"> • Loading and unloading operations for paints, chemicals and raw materials • Outdoor storage activities for raw materials, paints, empty containers, corn cob, chemicals, scrap metals • Outdoor manufacturing or processing activities such as grinding, cutting, degreasing, buffing, brazing, etc. • On site waste disposal practices for spent solvents, sludge, pickling baths, shavings, ingots pieces, refuse and waste piles.
Additional Non-Numeric Effluent Limits	
General	All fabricated metal products facilities should implement <i>BMPs</i> in the following areas of the site:

	<ul style="list-style-type: none"> • Metal fabricating areas <ul style="list-style-type: none"> • Storage areas for raw metal • Receiving, unloading, and loading areas • Heavy equipment storage • Metal working fluid areas • Unprotected liquid storage tanks • Chemical cleaners and rinse water • Raw steel collection areas • Paints and painting equipment • Vehicle and equipment maintenance areas • Hazardous waste storage areas • Transporting chemicals to storage areas • Finished products (galvanized) • Wooden pallets and empty drums
<p style="text-align: center;">Good Housekeeping Measures</p>	<p><i>Minimize</i> exposure of potential <i>pollutant</i> sources to precipitation. Prevent <i>pollutants</i>, including debris, from coming into contact with precipitation.</p> <p>Examples of <i>BMPs</i> for exposure minimization include, but are not limited to:</p> <ul style="list-style-type: none"> • Covering materials or activities with temporary structures (e.g., tarps) when wet weather is expected • Moving materials or activities to existing or new permanent structures (e.g., buildings, silos, sheds). • Keeping a dumpster lid closed
<p style="text-align: center;">Erosion & Sediment Controls</p>	<p>An Erosion and Sediment Control plan addressing the storm water run-on and run-off control systems in all areas of the facility must be developed by a qualified person and implemented by the <i>owner or operator</i>.</p> <p>The plan must be prepared in accordance with the most current version of the New York Standards and Specifications for Erosion and Sediment.. Consider using sediment traps, vegetated swales and strips, catch basin filters and sand filters to facilitate settling or filtering of sediments. Consider using green infrastructure practices such as vegetated swales and constructed wetlands to reduce export of metals in <i>stormwater</i>.</p>
Area Specific BMPs	
<p style="text-align: center;">Metal Fabricating Areas</p>	<p>The SWPPP shall describe and provide for implementation of measures for maintaining clean, dry, orderly conditions. The SWPPP shall document considerations of the following <i>BMPs</i> (or their equivalent):</p> <ul style="list-style-type: none"> • Use of dry clean up techniques shall be considered in the plan • Sweep fabrication areas frequently to avoid heavy accumulation of steel ingots, fines, and scrap.

	<ul style="list-style-type: none"> • Absorb dust through a vacuum system to avoid accumulation on roof tops and onto the ground. • Sweep all accessible paved areas on a regular basis. • Maintain floors in a clean and dry condition using dry cleanup techniques. • Remove waste and dispose of regularly • Train employees on good housekeeping measures
Storage Areas for Raw Materials	<p>The SWPPP shall describe and provide for implementation of measures to keep these areas free of conditions that could cause spills or leakage of materials. The SWPPP shall document considerations of the following <i>BMPs</i> (or their equivalents) :</p> <ul style="list-style-type: none"> • Store materials in a covered area whenever possible • Organize storage areas so there is easy access in case of a spill. • Label stored materials to aid in identifying spill contents • <i>Minimize</i> the amount of material stored to avoid corrosive activity from long-term exposed materials • Dike or berm the area to prevent or <i>minimize</i> run-on. • Keep area neat and orderly; stack neatly on pallets or off the ground. • Cover exposed materials. • Describe & implement measures controlling or recovering scrap metals, fines, and iron dust including measures for containing materials within storage handling areas
Lubricating & Hydraulic Fluid Operations	<p>The SWPPP shall document consideration of using devices or monitoring equipment or other devices to detect and control leaks /overflows. Consider the installation of perimeter controls such as dikes, curbs, grass filter strips, or other equivalent measures.</p>
Chemical Storage Areas	<p>The SWPPP shall describe and provide for implementation of proper storage methods that prevent <i>stormwater</i> contamination and accidental spillage. The SWPPP shall document considerations of the following <i>BMPs</i> (or their equivalents):</p> <ul style="list-style-type: none"> • The plan should include a program to inspect containers, and identify proper disposal methods. • Store drums as close to operational building as possible. • Label all drums with proper warning and handling instructions. • Train forklift operators to avoid puncturing drums.

Receiving Unloading & Storage Areas	<p>The SWPPP shall describe and provide for implementation of measures to prevent spills and leaks; plan for quick remedial clean up and instruct employees on clean up techniques and procedures. The SWPPP shall document considerations of the following <i>BMPs</i> (or their equivalents):</p> <ul style="list-style-type: none"> • Confine loading/unloading activities to designated areas outside drainage pathways and away from surface waters. • Close storm drains during loading/unloading activities in surrounding areas. • Use a dead-end sump where materials could be directed. • Inspect containers for leaks or damage prior to loading/unloading. • Avoid loading/unloading materials in the rain or provide cover or other protection for loading docks. • Provide diversion berms, dikes or grassed swales around the perimeter of the area to limit run-on. • Cover loading and unloading areas and perform these activities on an impervious pad to enable easy collection of spilled materials. • Slope the impervious concrete floor or pad to collect spills and leaks and convey them to proper containment and treatment. • Provide overhangs or door skirts to enclose trailer ends at truck loading/unloading docks For rail transfer, a drip pan shall be installed within the rails to collect spillage from the tank. • For rail transfer, a drip pan shall be installed within the rails to collect spillage from the tank • Where liquid or powdered materials are transferred in bulk to/from truck or rail cars, ensure hose connection points at storage containers are inside containment areas, or drip pans are used in areas where spillage may occur which are not in a containment area. • Enclose material handling systems. • Cover materials entering and leaving areas. • Use dry cleanup methods instead of washing the areas down. • Regularly sweep area to <i>minimize</i> debris on the ground. • Provide dust control if necessary. When controlling dust, sweep and/or apply water or materials that will not impact surface or ground water. • Develop and implement spill prevention, containment, and countermeasure (SPCC) plans. • Train employees in spill prevention, control, cleanup, and proper materials management techniques
Storage of Equipment	<p>The SWPPP shall describe and provide for implementation of measures for preparing equipment for storage and the proper method to store equipment. The SWPPP shall document considerations of the following <i>BMPs</i> (or their equivalents):</p> <ul style="list-style-type: none"> • Store Paint and painting equipment to <i>minimize</i> exposure to <i>stormwater</i>.

	<ul style="list-style-type: none"> • Vehicles should be stored indoors when possible. • If stored outdoors, use gravel, concrete, or other stabilized surfaces to <i>minimize</i> or prevent heavy equipment from creating ditches or other conveyances that would cause sedimentation runoff and increase TSS loadings. • Provide covering for outdoor storage areas. • Divert drainage to the grass swales, filter strips, retention ponds, or holding tanks. • Direct drainage systems away from high traffic areas into collection systems. • Clean equipment prior to storage
Metal Working Fluid Storage Areas	<p>The SWPPP shall describe and provide for implementation of measures for storage of metal working fluids. The SWPPP shall document considerations of the following <i>BMPs</i> (or their equivalents):</p> <ul style="list-style-type: none"> • Use pumps, spigots, and funnels when transferring metal working fluid to reduce the amount of lost fluid and the risk of spilling fluids. • Fix leaking seals and gaskets to prevent leaks. • Store used metal working fluid with fine metal dust indoors. • Use tight sealing lids on all fluid containers. • Use straw, clay absorbents, sawdust, or synthetic absorbents to confine or contain any spills. • Establish recycling programs for used fluids when possible. • Conduct daily inspections of each machine to identify problems and trends and reduce fluid waste
Cleaners & rinse Water	<p>The SWPPP shall describe and provide for implementation of measures to control/cleanup spills of solvents and other liquid cleaners. The SWPPP shall document considerations of the following <i>BMPs</i> (or their equivalents):</p> <ul style="list-style-type: none"> • Control sand buildup and disbursement from sand-blasting operations; • Prevent exposure of recyclable wastes. • Substitute environmentally benign cleaners when possible. • Use drip pans and other spill devices to collect spills or solvents and other liquid cleaners • Recycle wastewater. • Store recyclable waste indoors or in covered containers. • Substitute nontoxic cleaning agents when possible.
Inspections	<p>In addition to Inspections required in Part IV. Metal fabricators shall at a minimum include the following areas for inspection:</p> <ul style="list-style-type: none"> • Raw metal storage areas • Finished product storage areas • Material and chemical storage areas • Recycling areas • Loading and unloading areas • Equipment storage areas • Paint areas • Vehicle fueling and maintenance areas.
Employee Training	<p>In addition to training provided per Part II.A.8 At minimum, personnel must be trained to:</p> <ul style="list-style-type: none"> • Control <i>pollutants</i> at the source

	<ul style="list-style-type: none"> • Recognize unpermitted <i>discharges</i>. • Recognize a <i>reportable</i> spill • Implementation of spill containment and notification • Use dry clean up methods • Maintain an organized work environment to allow immediate access to spills • Properly store and label equipment and solvents and other materials 	
Comprehensive Site Inspection	<p>In addition to the requirements contained in Part IV.A, the site compliance evaluation shall also include inspections of:</p> <ul style="list-style-type: none"> • Areas associated with the storage of raw metals • Storage of spent solvents and chemicals • Outdoor paint areas • Roof drainage. <p>Potential <i>pollutants</i> include chromium, zinc, lubricating oil, solvents, aluminum, oil and grease, methyl ethyl ketone, steel and other related materials.</p>	
Numeric Effluent Limit	No Numeric Effluent Limits specified for this sector.	
Benchmarks	Metal fabricating facilities are required to monitor their <i>stormwater discharges</i> for the <i>pollutants</i> of concern listed in Table VII AA 1.	
	Sector VII-AA-1 Benchmark Monitoring Requirement	
	Pollutants of Concern	Benchmark Monitoring Cut-off Concentration
	Fabricated Metal Products Except Coating (SIC 3411 3471, 3482 3499, 3911 3915)	
	Total Nitrogen (TN)*	6 mg/L
	Total Recoverable Aluminum	750 ug/L
	Total Recoverable Iron	1 mg/L
	Total Recoverable Zinc	110 ug/L
	Fabricated Metal Coating & Engraving (SIC 3479)	
	Total Nitrogen (TN)*	6 mg/L
	Total Recoverable Zinc	110 ug/L
* Total Nitrogen is calculated as the sum of ammonia, nitrate-nitrite and organic nitrogen		

Sector AB – Transportation Equipment, Industrial & Commercial Machinery

Applicability	The requirements listed under this section apply to <i>stormwater discharges associated with industrial activity</i> from transportation equipment, industrial or commercial machinery manufacturing facilities (commonly described by SIC Major Group 35 (except SIC Code 357 - computer and office equipment covered by Sector AC), and SIC Major Group 37 (except SIC Code 373 - ship and boat building and repair cover by Sector R)).
Prohibitions - Non - Stormwater	Facilities that <i>discharge</i> wastewater, other than solely domestic wastewater, to the sanitary sewer system, must notify the <i>owner or operator</i> of the sanitary sewer and associated treatment works of its <i>discharge</i> . In such cases, a copy of a notification letter must be attached to the SWPPP .
SWPPP Requirements in addition to Part III	
Site Map	The site map shall identify where any of the following may be exposed to precipitation/surface runoff: <ul style="list-style-type: none"> • Vents and stacks from metal processing and similar operations.
Numeric Effluent Limits	No Numeric Effluent Limits specified for this sector.
Benchmarks	No <i>Benchmark Monitoring</i> or reporting is required for this sector.

Sector AC – Electronic, Electrical Equipment & Components, Photographic & Optical Goods

Applicability	<p>The requirements listed under this section apply to <i>stormwater discharges associated with industrial activity</i> from facilities that manufacture:</p> <ul style="list-style-type: none"> • Electronic and other electrical equipment and components, except computer equipment (SIC Major Group 36) • Measuring, analyzing, and controlling instruments • Photographic, medical and optical goods • Watches and clocks (SIC Major Group 38) • Computer and office equipment (SIC Code 357). 	
Additional Non-Numeric Effluent Limits		
Discharges to Copper Impaired Waters	<p>If the facility discharges to a Copper Impaired waterbody, the owner or operator shall prevent the exposure of copper sources and copper containing materials or processes to <i>stormwater</i>. These materials shall be protected by a storm-resistant shelter to prevent exposure to rain, snow, snowmelt, and/or runoff.</p>	
Numeric Effluent Limits	<p>No Numeric Effluent Limits specified for this sector.</p>	
Benchmarks	<p>Facilities under this sector are required to monitor their <i>stormwater discharges</i> for the <i>pollutants</i> of concern listed in Table VII-AC-1.</p>	
	Sector VII-AC-1 Benchmark Monitoring Requirement	
	<i>Pollutants</i> of Concern	<i>Benchmark Monitoring</i> Cut-off Concentration
	<p>Electronic and Other Electrical Equipment and Components, Except Computer Equipment (SIC Major Group 36); Measuring, Analyzing, and Controlling Instruments; Photographic, Medical and Optical Goods; Watches and Clocks (SIC Major Group 38) and Computer and Office Equipment (SIC Code 357)</p>	
	Total Suspended Solids (TSS)	100 mg/L
	Total Recoverable Copper	12 ug/L
	Total Recoverable Lead	69 ug/L

Appendix A – Definitions and Acronyms

Acronyms

ACR – Annual Certification Report
BOD5 – Biochemical Oxygen Demand (5-day test)
BMP – Best Management Practice
BAT – Best Available Technology Economically Achievable
BPT - Best Practicable Technology
CBS - Chemical Bulk Storage
CFR – Code of Federal Regulations
COD – Chemical Oxygen Demand
CWA – Clean Water Act (or the Federal Water Pollution Control Act, 33 U.S.C. §1251 et seq)
DMR – Discharge Monitoring Report
ECL - Environmental Conservation Law
ELG – Effluent Limitations Guidelines
EPA – U. S. Environmental Protection Agency
EPCRA – Emergency Planning and Community Right-to-know Act
MDL - Method Detection Limit
MGD – Million Gallons per Day
MS4 – Municipal Separate Storm Sewer System
MSGP – Multi-Sector General Permit
NOI – Notice of Intent
NOT – Notice of Termination
NPDES – National Pollutant Discharge Elimination System
NRC – National Response Center
NTU – Nephelometric Turbidity Unit
PBS - Petroleum Bulk Storage
PQL - Practical Quantitation Limit
RCRA – Resource Conservation and Recovery Act
RQ – Reportable Quantity
SIC – Standard Industrial Classification
SPCC – Spill Prevention, Control, and Countermeasure
SWPPP – Stormwater Pollution Prevention Plan
TMDL – Total Maximum Daily Load
TSS – Total Suspended Solids
USGS – United States Geological Survey

Definitions

Note: Additional definitions are provided within the Part VII industrial sectors for definitions that are specific for those industries.

Annual Certification Report (ACR) - is the primary mechanism for reporting to the *Department*. Every facility covered by this general permit must complete and submit an *ACR* form in accordance with the submission deadlines in Part VI.B -Table VI.1.

Alternative General Permit - is a general permit different from the MSGP that covers some or all of the authorized discharges.

Best Management Practices (BMPs) - means schedules of activities, prohibitions of practices, maintenance procedures, and other management practices to prevent or reduce the pollution of waters of the *State*. *BMPs* also include treatment requirements (if determined necessary by the *owner or operator*), operating procedures, and practices to control plant site runoff, spillage and leaks, sludge or waste disposal, or drainage from raw material storage.

Benchmark Monitoring – means sampling and analyses of *stormwater discharges* for parameters specified in Part VII for specific sectors.

Benchmark Monitoring Cut-off Concentrations – means *pollutant* levels that are intended to provide a guideline for the *owner or operator* to determine the overall effectiveness of the SWPPP in controlling the *discharge* of *pollutants* to receiving waters. The *benchmark* concentrations do not constitute direct *effluent limitations*. Therefore, a *benchmark* exceedance is not a permit violation in and of itself. It does, however, signal the need for the *owner or operator* to evaluate potential sources of *stormwater* contaminants at the facility.

Best Practicable Control Technology Currently Available (BPT) – means the first level of technology-based standards established by the CWA to control *pollutants discharged* to waters of the U.S. BPT effluent limitations guidelines are generally based on the average of the best existing performance by plants within an industrial category or subcategory.

Co-located Industrial Activities - occurs when a facility has industrial activities included in more than one industrial sector. *Stormwater discharges* from co-located activities must comply with requirements for all relevant sectors.

Commence (Commencement of) Construction Activities - means the initial disturbance of soils associated with clearing, grading or excavation activities; or other construction related activities that disturb or expose soils such as demolition, stockpiling of fill material, and the initial installation of erosion and sediment control practices required in the SWPPP. See definition for “*Construction Activity(ies)*” also.

Construction Activity(ies) - means any clearing, grading, excavation, filling, demolition or stockpiling activities that result in soil disturbance. Clearing activities can include, but are not limited to, logging equipment operation, the cutting and skidding of trees, stump removal and/or brush root removal. Construction activity does not include routine maintenance that is performed to maintain the original line and grade, hydraulic capacity, or original purpose of a facility.

Construction SWPPP – as defined per the NYSDEC SPDES General Permit for *Stormwater* Discharges from Construction Activity, GP-0-15-002.

Control Measure - refers to any BMP *stormwater* control or other method (including *non-numeric effluent limitations*) used to prevent or reduce the *discharge* of *pollutants* to *waters of the United States*.

Corrective Action - any action taken, or required to be taken, to (1) repair, modify, or replace any control measure used at the site; (2) clean up and dispose of spills, releases, or other deposits found on the site; and (3) remedy a permit violation.

Department - means the New York State *Department* of Environmental Conservation as well as meaning the *Department's* designated agent.

Discharge(s) - means any addition of any *pollutant* to *waters of the State* through an outlet or *point source*.

Discharge Monitoring Report (DMR) - means a report submitted by the *owner or operator* to the *Department* summarizing the effluent monitoring results obtained by the *owner or operator* over periods of time as specified in the *SPDES* permit.

Environmental Conservation Law (ECL) - means chapter 43-B of the Consolidated Laws of the State of New York, entitled the *Environmental Conservation Law*.

Effluent Limitation - means any restriction on quantities, quality, rates and concentrations of chemical, physical, biological, and other constituents of effluents that are *discharged* into waters of the *State*.

Effluent Limitation Guideline (ELG) - means toxic or pretreatment *effluent limitations* contained in 40 CFR Parts 405 to 471 (see 6 NYCRR 750-1.24 of this Part).

General SPDES permit - means a *SPDES* permit issued pursuant to 6 NYCRR Part 750-1.21 authorizing a category of *discharges*.

Final Stabilization - means that all soil disturbance activities have ceased and a uniform, perennial vegetative cover with a density of eighty (80) percent over the entire pervious surface has been established; or other equivalent stabilization measures, such as permanent landscape mulches, rock rip-rap or washed/crushed stone have been

applied on all disturbed areas that are not covered by permanent structures, concrete or pavement.

Groundwater - means waters in the saturated zone. The saturated zone is a subsurface zone in which all the interstices are filled with water under pressure greater than that of the atmosphere. Although the zone may contain gas-filled interstices or interstices filled with fluids other than water, it is still considered saturated.

High Volume Hydraulic Fracturing – means the stimulation of a well using 300,000 gallons or more of water as the primary carrier fluid or base fluid in the hydraulic fracturing fluid for well completion.

Hotspot – Area where land use or activities generate highly contaminated runoff, with concentrations of *pollutants* in excess of those typically found in stormwater.

Impaired Water (or “Impaired Waterbody” or “Impaired Waterbodies”) - A water is impaired if it is determined that it does not meet applicable water quality standards, which are adopted for each water class to protect the best uses designated for that class. Impaired waters are those waters 1) identified on the 2016 New York State Section 303(d) List of *Impaired/TMDL* Waters, or 2) designated as an Integrated Reporting Category (IRC) 4a or 4b waters. An IRC 4a water is an impaired water for which a TMDL to address the impairing *pollutant/cause* has been established. An IRC 4b water is an impaired water where a TMDL is not necessary because other required control measures are expected to result in restoration in a reasonable period of time.

Impervious Area (Cover) - means all impermeable surfaces that cannot effectively infiltrate rainfall. This includes paved, concrete and gravel surfaces (i.e. parking lots, driveways, roads, runways and sidewalks); building rooftops and miscellaneous impermeable structures such as patios, pools, and sheds

Individual SPDES Permit - means a *SPDES* "permit" issued to a single facility in one location in accordance with this Part (as distinguished from a general *SPDES* permit).

Industrial Activity - the 11 categories of industrial activities included in the definition of "*stormwater discharges associated with industrial activity.*"

Industrial Waste - means any liquid, gaseous, solid or waste substance, or a combination thereof, resulting from any process of industry, manufacturing, trade, or business or from the development or recovery of any natural resources, that may cause or might reasonably be expected to cause pollution of the waters of the State in contravention of the standards adopted pursuant to the Environmental Conservation Law, article 17.

Measurable Storm Event - a storm event with at least 0.1 inch of precipitation that produces runoff.

Method Detection Limit - means the level at which the analytical procedure referenced is capable of determining with a 99 percent probability that the substance is present. The precision at this level is plus or minus 100 percent.

Minimize – means reduce and/or eliminate to the extent achievable using *control measures* (including *BMPs*) that are technologically available and economically practicable and achievable in the light of best industry practice.

Municipality - means any county, town, city, village, district corporation, special improvement district, sewer authority or agency thereof.

Municipal Separate Storm Sewer System (MS4)- a conveyance or system of conveyances (including roads with drainage systems, municipal streets, catch basins, curbs, gutters, ditches, man-made channels, or storm drains):

1. Owned or operated by a *State*, city, town, borough, county, parish, district, association, or other public body (created by or pursuant to *State* law) having jurisdiction over disposal of sewage, *industrial wastes*, *stormwater*, or other wastes, including special districts under *State* law such as a sewer district, flood control district or drainage district, or similar entity, or an Indian tribe or an authorized Indian tribal organization, or a designated and approved management agency under section 208 of the CWA that *discharges to waters of the United States*;
2. Designed or used for collecting or conveying *stormwater*;
3. Which is not a combined sewer; and
4. Which is not part of a Publicly Owned Treatment Works (POTW) as defined at 40 CFR 122.2.

National Pollutant Discharge Elimination System (NPDES) - means the national system for the issuance of wastewater and *stormwater* permits under the Federal Water Pollution Control Act (Clean Water Act).

No exposure - all industrial materials or activities are protected by a storm-resistant shelter to prevent exposure to rain, snow, snowmelt, and/or runoff.

Other wastes - means garbage, refuse, decayed wood, sawdust, shavings, bark, sand, lime, cinders, ashes, offal, oil, tar, dyestuffs, acids, chemicals, leachate, sludge, salt and all other discarded matter not sewage or industrial waste that may cause or might reasonably be expected to cause pollution of the waters of the State in contravention of the standards adopted pursuant to the Environmental Conservation Law, article 17.

Outfall - means the terminus of a sewer system, or the point of emergence of any waterborne sewage, *industrial waste* or other wastes or the effluent therefrom, into the waters of the *State*.

Owner or Operator - means the *owner or operator* of any facility or activity subject to regulation under 6 NYCRR Part 750. In accordance with 6 NYCRR Part 750-1.6(a), when a facility or activity is owned by one person but is operated by another person, it is the operator's duty to obtain a permit

Person or Persons - means any individual, public or private corporation, political subdivision, government agency, *municipality*, partnership, association, firm, trust, estate or any other legal entity whatsoever.

Point Source - means any discernible, confined and discrete conveyance, including but not limited to any pipe, ditch, channel, tunnel, conduit, well, discrete fissure, container, rolling stock, concentrated animal feeding operation, vessel or other floating craft, or landfill leachate collection system from which *pollutants* are or may be *discharged*.

Pollutant(s) - means dredged spoil, filter backwash, solid waste, incinerator residue, sewage, garbage, sewage sludge, munitions, chemical wastes, biological materials, radioactive materials, heat, wrecked or discarded equipment, rock, sand and industrial, municipal, agricultural waste and ballast *discharged* into water; which may cause or might reasonably be expected to cause pollution of the *waters of the State* in contravention of the standards or guidance values adopted as provided in Parts 700 et seq of this Title.

Primary Industrial Activity - The operation that generates the most revenue or employs the most personnel is the operation in which the facility is primarily engaged. In situations where the vast majority of on-site activity falls within one SIC code, that activity may be the *primary industrial activity*. The primary industrial determination is based on the value of receipts or revenues or, if such information is not available for a particular facility, the number of employees or production rate for each process may be compared.

Qualified Person - A qualified person may be either a facility employee or hired consultant who is familiar with the day-to-day operations associated with their assigned responsibilities at the facility. The qualified person possesses the knowledge and skills to assess conditions, operations and activities at the facility that could impact stormwater quality and can evaluate the effectiveness of control measures being implemented as part of the requirements of the permit. The owner/operator may designate more than one individual as the qualified person.

If the control measures include Erosion and Sediment controls, then the person selected to inspect the erosion & sediment controls must be knowledgeable in the principles and practices of erosion and sediment control and must receive four (4) hours of Department endorsed training in proper erosion and sediment control principles from

a Soil and Water Conservation District, or other Department endorsed entity. After receiving the initial training, the qualified person shall receive four (4) hours of training, every three (3) years.

Note: Inspections of any post-construction *stormwater* management practices that include structural components, such as a dam for an impoundment, shall be performed by a Qualified Professional.

Qualified Professional - means a person that is knowledgeable in the principles and practices of *stormwater* management and treatment, such as a licensed Professional Engineer, Registered Landscape Architect or other *Department* endorsed individual(s). Individuals preparing SWPPPs that require the post-construction *stormwater* management practice component must have an understanding of the principles of hydrology, water quality management practice design, water quantity control design, and, in many cases, the principles of hydraulics in order to prepare a SWPPP that conforms to the *Department's* technical standard. All components of the SWPPP that involve the practice of engineering, as defined by the NYS Education Law (see Article 145), shall be prepared by, or under the direct supervision of, a professional engineer licensed to practice in the State of New York.

Qualifying Storm Event – a storm event with at least 0.1 inch of precipitation (defined as a "measurable" event), providing the interval from the preceding measurable storm is at least 72 hours. The 72-hour storm interval is waived if the preceding measurable storm did not result in a *stormwater discharge* (e.g., a storm events in excess of 0.1 inches may not result in a *stormwater discharge* at some facilities), or if the *owner or operator* is able to document that less than a 72 hour interval is representative for local storm events during the sampling period.

Reportable Quantity Release - a release of a hazardous substance at or above the established legal threshold that requires emergency notification. Refer to 40 CFR Parts 110, 177, and 302 for complete definitions and reportable quantities for which notification is required.

Runoff Coefficient - the fraction of total rainfall that will appear at the conveyance as runoff.

Run-on - sources of stormwater that drain from land located upslope or upstream from, and adjacent to, the facility.

Significant Materials - includes, but is not limited to: raw materials; fuels; materials such as solvents, detergents, and plastic pellets; finished materials such as metallic products; raw materials used in food processing or production; hazardous substances designated under section 101(14) of CERCLA; any chemical the facility is required to report pursuant to section 313 of Title III of SARA; fertilizers; pesticides; and waste products such as ashes, slag and sludge that have the potential to be released with *stormwater discharges*.

State - means the State of New York.

State Pollutant Discharge Elimination System (SPDES) - means the system established pursuant to Article 17 of the *ECL* and this Part for issuance of permits authorizing *discharges* to the waters of the *State*.

Stormwater - means that portion of precipitation that, once having fallen to the ground, is in excess of the evaporative or infiltrative capacity of soils, or the retentive capacity of surface features, which flows or will flow off the land by surface runoff to waters of the *State*.

Stormwater Discharges Associated with Industrial Activity - the *discharge* from any conveyance that is used for collecting and conveying *stormwater* and that is directly related to manufacturing, processing or raw materials storage areas at an industrial plant. The term does not include *discharges* from facilities or activities excluded from the *NPDES* program under Part 122. For the categories of industries identified in this section, the term includes, but is not limited to, *stormwater discharges* from industrial plant yards; immediate access roads and rail lines used or traveled by carriers of raw materials, manufactured products, waste material, or by-products used or created by the facility; material handling sites; refuse sites; sites used for the application or disposal of process waste waters (as defined at 40 CFR Part 401 of this chapter); sites used for the storage and maintenance of material handling equipment; sites used for residual treatment, storage, or disposal; shipping and receiving areas; manufacturing buildings; storage areas (including tank farms) for raw materials, and intermediate and final products; and areas where *industrial activity* has taken place in the past and *significant materials* remain and are exposed to *stormwater*. For the purposes of this paragraph, material handling activities include storage, loading and unloading, transportation, or conveyance of any raw material, intermediate product, final product, by-product or waste product. The term excludes areas located on plant lands separate from the plant's industrial activities, such as office buildings and accompanying parking lots as long as the drainage from the excluded areas is not mixed with *stormwater* drained from the above described areas. Industrial facilities include those that are federally, *State*, or municipally owned or operated that meet the description of the facilities listed in Appendix D of this permit. The term also includes those facilities designated under the provisions of 40 CFR 122.26(a)(1)(v).

Surface Waters of the State - shall be construed to include lakes, bays, sounds, ponds, impounding reservoirs, springs, rivers, streams, creeks, estuaries, marshes, inlets, canals, the Atlantic ocean within the territorial seas of the *State* of New York and all other bodies of surface water, natural or artificial, inland or coastal, fresh or salt, public or private (except those private waters that do not combine or effect a junction with natural surface or underground waters), which are wholly or partially within or bordering the *State* or within its jurisdiction. Waters of the *State* are further defined in 6 NYCRR Parts 800 to 941.

Technical Standards – means the New York State *Stormwater* Management Design Manual (2015) and New York State Standards and Specifications for Erosion and Sediment Control (2016).

Temporary Stabilization - means that exposed soil has been covered with material(s) as set forth in the technical standard, New York Standards and Specifications for Erosion and Sediment Control, to prevent the exposed soil from eroding. The materials can include, but are not limited to, mulch, seed and mulch, and erosion control mats (e.g. jute twisted yarn, excelsior wood fiber mats).

Total Maximum Daily Loads (TMDLs) - A TMDL is the sum of the allowable loads of a single *pollutant* from all contributing point and nonpoint sources. It is a calculation of the maximum amount of a *pollutant* that a *waterbody* can receive and still meet water quality standards, and an allocation of that amount to the *pollutant's* sources. A TMDL stipulates waste load allocations (WLAs) for *point source discharges*, load allocations (LAs) for nonpoint sources, and a margin of safety (MOS).

Waters of the United States - means:

1. All waters which are currently used, were used in the past, or may be susceptible to use in interstate or foreign commerce, including all waters that are subject to the ebb and flow of the tide;
2. All interstate waters, including interstate "wetlands";
3. All other waters, such as interstate lakes, rivers, streams (including intermittent streams), mudflats, sandflats, wetlands, sloughs, prairie potholes, wet meadows, playa lakes, or natural ponds, the use, degradation, or destruction of which would affect or could affect interstate or foreign commerce, including any such waters:
 - a. Which are or could be used by interstate or foreign travelers for recreational or other purposes;
 - b. From which fish or shellfish are or could be taken and sold in interstate or foreign commerce; or
 - c. Which are or could be used for industrial purposes by industries in interstate commerce;
 - d. All impoundments of waters otherwise defined as *waters of the United States* under this definition;
 - e. Tributaries of waters identified in paragraphs (1) through (4) of this definition;
 - f. The territorial sea; and

- g. Wetlands adjacent to waters (other than waters that are themselves wetlands) identified in paragraphs 1 through 6 of this definition.

Water Quality Standard - means such measures of purity or quality for any waters in relation to their reasonable and necessary use as promulgated in 6 NYCRR Part 700 et seq.

Appendix B - Sectors of Industrial Activity Covered by this Permit

SECTORS OF INDUSTRIAL ACTIVITY COVERED BY THIS PERMIT	
Activities Consistent with Descriptions and SIC Code or Activity Code	Activity Represented
Sector A: Timber Products	
2411	Log Storage and Handling (Wet deck storage areas are only authorized if no chemical additives are used in the spray water or applied to the logs).
2421	General Sawmills and Planning Mills
2426	Hardwood Dimension and Flooring Mills
2429	Special Product Sawmills, Not Elsewhere Classified
2431-2439 (except 2434 - see Sector W)	Millwork, Veneer, Plywood, and Structural Wood
2441, 2448, 2449	Wood Containers
2451, 2452	Wood Buildings and Mobile Homes
2491	Wood Preserving
2493	Reconstituted Wood Products
2499	Wood Products, Not Elsewhere Classified
Sector B: Paper and Allied Products	
2611	Pulp Mills
2621	Paper Mill
2631	Paperboard Mills
2652-2657	Paperboard Containers and Boxes
2671-2679	Converted Paper and Paperboard Products, Except Containers and Boxes
Sector C: Chemical and Allied Products	
2812-2819	Industrial Inorganic Chemicals
2821-2824	Plastics Materials and Synthetic Resins, Synthetic Rubber, Cellulosic and Other Manmade Fibers Except Glass
2833-2836	Medicinal Chemicals and Botanical Products; Pharmaceutical Preparations; In Vitro and In Vivo Diagnostic Substances; Biological Products, Except Diagnostic Substances
2841-2844	Soaps, Detergents, and Cleaning Preparations; Perfumes, Cosmetics, and Other Toilet Preparations
2851	Paints, Varnishes, Lacquers, Enamels, and Allied Products
2861-2869	Industrial Organic Chemicals
2873-2879	Agricultural Chemicals
2891-2899	Miscellaneous Chemical Products
2911	Petroleum Refineries
3952 (limited to list)	Inks and Paints, Including China Painting Enamels, India Ink, Drawing Ink, Platinum Paints for Burnt Wood or Leather Work, Paints for China Painting, Artist's Paints and Artist's Watercolors

SECTORS OF INDUSTRIAL ACTIVITY COVERED BY THIS PERMIT (Continued)	
Activities Consistent with Descriptions and SIC Code or Activity Code	Activity Represented
Sector D: Asphalt Paving and Roofing Materials and Lubricants	
2951, 2952	Asphalt Paving and Roofing Materials
2992, 2999	Miscellaneous Products of Petroleum and Coal
Sector E: Glass Clay, Cement, Concrete, and Gypsum Products	
3211	Flat Glass
3221, 3229	Glass and Glassware, Pressed or Blown
3231	Glass Products Made of Purchased Glass
3241	Hydraulic Cement
3251-3259	Structural Clay Products
3261-3269	Pottery and Related Products
3271-3275	Concrete, Gypsum and Plaster Products
3281	Cut Stone and Stone Products
3291-3299	Abrasive, Asbestos, and Miscellaneous Non-metallic Mineral Products
Sector F: Primary Metals	
3312-3317	Steel Works, Blast Furnaces, and Rolling and Finishing Mills
3321-3325	Iron and Steel Foundries
3331-3339	Primary Smelting and Refining of Nonferrous Metals
3341	Secondary Smelting and Refining of Nonferrous Metals
3351-3357	Rolling, Drawing, and Extruding of Nonferrous Metals
3363-3369	Nonferrous Foundries (Castings)
3398, 3399	Miscellaneous Primary Metal Products
Sector G: Metal Mining (Ore Mining and Dressing)	
1011	Iron Ores
1021	Copper Ores
1031	Lead and Zinc Ores
1041, 1044	Gold and Silver Ores
1061	Ferroalloy Ores, Except Vanadium
1081	Metal Mining Services
1094, 1099	Miscellaneous Metal Ores
Sector H: [Reserved]	
Sector I: Oil and Gas Extraction and Refining	
1311	Crude Petroleum and Natural Gas
1321	Natural Gas Liquids
1381-1389	Oil and Gas Field Services

SECTORS OF INDUSTRIAL ACTIVITY COVERED BY THIS PERMIT (Continued)

Activities Consistent with Descriptions and SIC Code or Activity Code	Activity Represented
Sector J: Mineral Mining and Dressing	
1411	Dimension Stone
1422-1429	Crushed and Broken Stone, Including Rip Rap
1442, 1446	Sand and Gravel
1455, 1459	Clay, Ceramic, and Refractory Materials
1474-1479	Chemical and Fertilizer Mineral Mining
1481	Nonmetallic Minerals Services, Except Fuels
1499	Miscellaneous Nonmetallic Minerals, Except Fuels
Sector K: Hazardous Waste Treatment, Storage, or Disposal Facilities	
HZ	Hazardous Waste Treatment Storage or Disposal
Sector L: Landfills and Land Application Sites	
LF	Landfills, Land Application Sites, and Non-Compliant Landfills
Sector M: Automobile Salvage Yards	
5015	Automobile Salvage Yards
Sector N: Scrap Recycling Facilities	
5093	Scrap Recycling Facilities, Including Transfer Stations Accepting Household Recyclables
4499 (limited to list)	Dismantling Ships, Marine Salvaging, and Marine Wrecking - Ships For Scrap
Sector O: Steam Electric Generating Facilities	
SE	Steam Electric Generating Facilities
Sector P: Land Transportation and/or Warehousing	
4011, 4013	Railroad Transportation
4111-4173	Local and Highway Passenger Transportation
4212-4231	Motor Freight Transportation and/or Warehousing
4311	United States Postal Service
5171	Petroleum Bulk Stations and Terminals
Sector Q: Water Transportation	
4412-4499(except 4499 facilities as specified in Sector N)	Water Transportation, Marinas, Yacht Clubs
Sector R: Ship and Boat Building or Repairing Yards	
3731, 3732	Ship and Boat Building or Repairing Yards
Sector S: Air Transportation	
4512-4581	Air Transportation Facilities

SECTORS OF INDUSTRIAL ACTIVITY COVERED BY THIS PERMIT (Continued)	
Activities Consistent with Descriptions and SIC Code or Activity Code	Activity Represented
Sector T: Treatment Works	
TW	Treatment Works
Sector U: Food and Kindred Products	
2011-2015	Meat Products
2021-2026	Dairy Products
2032-2038	Canned, Frozen and Preserved Fruits, Vegetables & Food Specialties
2041-2048	Grain Mill Products
2051-2053	Bakery Products
2061-2068	Sugar and Confectionery Products
2074-2079	Fats and Oils
2082-2087	Beverages
2091-2099	Miscellaneous Food Preparations and Kindred Products
2111-2141	Tobacco Products
Sector V: Textile Mills, Apparel, and Other Fabric Product Manufacturing, Leather and Leather Products	
2211-2299	Textile Mill Products
2311-2399	Apparel and Other Finished Products Made From Fabrics and Similar Materials
3131-3199 (3111 - see Sector Z)	Leather and Leather Products, except Leather Tanning and Finishing
Sector W: Furniture and Fixtures	
2434	Wood Kitchen Cabinets
2511-2599	Furniture and Fixtures
Sector X: Printing and Publishing	
2711-2796	Printing, Publishing, and Allied Industries
Sector Y: Rubber, Miscellaneous Plastic Products, and Miscellaneous Manufacturing Industries	
3011	Tires and Inner Tubes
3021	Rubber and Plastics Footwear
3052, 3053	Gaskets, Packing, and Sealing Devices and Rubber and Plastics Hose and Belting
3061, 3069	Fabricated Rubber Products, Not Elsewhere Classified
3081-3089	Miscellaneous Plastics Products
3931	Musical Instruments
3942-3949	Dolls, Toys, Games and Sporting and Athletic Goods
3951-3955 (except 3952 facilities specified in Sector C)	Pens, Pencils, and Other Artists' Materials
3961, 3965	Costume Jewelry, Costume Novelties, Buttons, and Miscellaneous Notions, Except Precious Metal. Miscellaneous Manufacturing Industries.
3991-3999	Miscellaneous Manufacturing Industries.

SECTORS OF INDUSTRIAL ACTIVITY COVERED BY THIS PERMIT (Continued)	
Activities Consistent with Descriptions and SIC Code or Activity Code	Activity Represented
Sector Z: Leather Tanning and Finishing	
3111	Leather Tanning, Currying and Finishing
Sector AA: Fabricated Metal Products	
3411–3499	Fabricated Metal Products, Except Machinery and Transportation Equipment
3911–3915	Jewelry, Silverware, and Plated Ware
Sector AB: Transportation Equipment, Industrial or Commercial Machinery	
3511-3599 (except 3571-3579 - see Sector AC)	Industrial and Commercial Machinery (Except Computer and Office Equipment).
3711-3799 (except 3731, 3732 - see Sector R)	Transportation Equipment (Except Ship and Boat Building and Repairing)
Sector AC: Electronic, Electrical, Photographic, and Optical Goods	
3571-3579	Computer and Office Equipment
3612-3699	Electronic, Electrical Equipment and Components, Except Computer Equipment
3812-3873	Measuring, Analyzing and Controlling Instrument; Photographic and Optical Goods

Appendix C - Sectors Subject to Benchmark Monitoring Requirements

INDUSTRIAL SECTORS SUBJECT TO BENCHMARK MONITORING		
Industry Sector ¹	Industry Sub-sector	Benchmark Monitoring Parameters
A	General Sawmills and Planing Mills	TSS, COD, Zinc, TN, Phosphorus
	Wood Preserving Facilities	Arsenic, Chromium, Copper
	Log Storage and Handling	TSS
	Hardwood Dimension and Flooring Mills	TSS, COD
B	Paperboard Mills	COD
C	Industrial Inorganic Chemicals	Aluminum, Iron, TN
	Plastics, Synthetic Resins, etc	Zinc
	Soaps, Detergents, Cosmetics, Perfumes	TN, Zinc
	Agricultural Chemicals	TN, Iron, Lead, Zinc, Phosphorus
	Petroleum Refining	Oil & Grease, Lead, Zinc, BTEX
D	Asphalt Paving and Roofing Materials	TSS
E	Clay Products	Aluminum
	Concrete Products	TSS, pH, Iron
F	Steel Works, Blast Furnaces, and Rolling and Finishing Mills	Aluminum, Zinc
	Iron and Steel Foundries	Aluminum, TSS, Copper, Iron, Zinc
	Nonferrous Rolling, Drawing & Extruding	Copper, Zinc
	Nonferrous Foundries (Castings)	Copper, Zinc
G ²	Ore Mining and Dressing	TSS, COD, pH, turbidity, metals
H	[Reserved]	
I	Oil and Gas Extraction	TSS, Chlorides, pH, ⁴
J	Sand and Gravel Mining	TSS, TN, Iron, Zinc, Phosphorus
	Dimension and Crushed Stone and Non- metallic Minerals (except fuels)	TSS
K	Hazardous Waste Treatment, Storage or Disposal	TSS, COD, TN, Arsenic, Cadmium, Cyanide, Lead, Magnesium, Mercury, Selenium, Silver

1 - Table does not include parameters for compliance monitoring under *effluent limitations guidelines*.
2 - See Sector G (Part VII.G) for additional monitoring *discharges* from waste rock and overburden piles from active ore mining or dressing facilities which includes TSS, COD, turbidity, pH, hardness, and metals.
3 - Monitoring requirement for airports with deicing activities utilizing more than 100 tons of urea or more than 100,000 gallons of glycol per year.
4 - BTEX is Benzene, Ethylbenze, Toluene and Xylene.

INDUSTRIAL SECTORS SUBJECT TO BENCHMARK MONITORING (Continued)

Industry Sector ¹	Industry Sub-sector	Benchmark Monitoring Parameters
L	Landfills, Land Application Sites, and Open.. Dumps	Iron, TSS, TN, Phosphorus
	Landfills, Land Application Sites and Open .. Dumps, Except Municipal Solid Waste Landfill Sites Closed in accordance with 40 CFR 258.60	Iron, TSS
M	Automobile Salvage Yards	TSS, Oil & Grease, Aluminum, Iron, Lead, BTEX ⁴
N	Scrap Recycling/Waste Recycling Facilities .. and Facilities Engaged in Ship Dismantling, Marine Salvaging & Marine Wrecking for Scrap	TSS, COD, Oil & Grease, Aluminum, Cadmium, Copper, Chromium, Iron, Lead, Zinc
	Scrap & Waste Recycling Facilities which include <i>Stormwater Discharges</i> from Shredder Fluff Storage Areas	TSS, COD, Oil & Grease, Aluminum, Cadmium, Copper, Chromium, Iron, Lead, Zinc, Mercury, PCBs, BTEX ⁴
O	Steam Electric Generating Facilities	Iron, Oil & Grease, PCBs
P	Land Transportation and/or Warehousing, including Transfer Stations with vehicle maintenance facilities	Oil & Grease, COD, BTEX ⁴
Q	Water Transportation Facilities	Aluminum, Iron, Zinc, Lead
S	Airports with deicing activities ³	COD, BOD, TN, pH
T	Treatment Works	COD
U	Grain Mill Products	TSS, TN, Phosphorus
	Fats and Oils Products	BOD, COD, TSS, TN, Phosphorus
Y	Rubber Products	Zinc
Z	Leather Tanning and Finishing	TN, Chromium
AA	Fabricated Metal Products Except Coating	TN, Aluminum, Iron, Zinc
	Fabricated Metal Coating and Engraving	TN, Zinc
AC	Electronic, Electrical Equipment and Components, Photographic & Optical Goods	TSS, Copper, Lead

1 - Table does not include parameters for compliance monitoring under *effluent limitations guidelines*.
 2 - See Sector G (Part VII.G) for additional monitoring *discharges* from waste rock and overburden piles from active ore mining or dressing facilities which includes TSS, COD, turbidity, pH, hardness, and metals.
 3 - Monitoring requirement for airports with deicing activities utilizing more than 100 tons of urea or more than 100,000 gallons of glycol per year.
 4 - BTEX is Benzene, Ethylbenze, Toluene and Xylene.

Appendix D - Compliance Monitoring Requirements - Industrial Activities Subject to Effluent Limitation Guidelines

Effluent limitation guidelines applicable to <i>discharges</i> that may be eligible for permit coverage	
Effluent Limitation Guideline	Sectors With Affected Facilities
<i>Discharges</i> resulting from spray down or intentional wetting of logs at wet deck storage areas (40 CFR Part 429, Subpart I (2002) (established January 26, 1981))	A
Contaminated runoff from phosphate fertilizer manufacturing facilities (40 CFR Part 418 Subpart A (2002) (established April 8, 1974))	C
Runoff from asphalt emulsion facilities (40 CFR Part 443 Subpart A (2002) (established July 24, 1975))	D
Runoff from material storage piles at cement manufacturing facilities (40 CFR Part 411 Subpart C (2002) (established February 23, 1977))	E
Mine dewatering <i>discharges</i> at crushed stone mines (40 CFR Part 436, Subpart B)	J
Mine dewatering <i>discharges</i> at construction sand and gravel mines (40 CFR Part 436, Subpart C)	J
Mine dewatering <i>discharges</i> at industrial sand mines (40 CFR Part 436, Subpart D)	J
Runoff from landfills, (40 CFR Part 445, Subpart A and B (2002) (established February 2, 2000))	K & L
Coal pile runoff at steam electric generating facilities (40 CFR Part 423 (2002) (established November 19, 1982))	O
Runoff containing urea from airfield pavement deicing at existing and new primary airports with 1,000 or more annual non-propeller aircraft departures (40 CFR Part 449, (established May 16, 2012))	S

Appendix E - Additional Information for New *Discharges*

Any facility with new *stormwater discharges associated with industrial activity* which require any other *Uniform Procedures Act* (<http://www.dec.ny.gov/permits/6081.html>) permit(s) (*Environmental Conservation Law*, 6 NYCRR Part 621) are not initially eligible for coverage under this general permit. The *discharger* must first complete a Short Environmental Assessment Form which can be found in Appendix B of 6 NYCRR Part 617.20 or on the web at <http://www.dec.ny.gov/regs/6191.html>, and submit it to the appropriate NYSDEC Regional Permit Administrator. Upon a review of the Short Environmental Assessment Form and the information specified below, the *Department* may authorize the applicant to submit a Notice of Intent (NOI) to obtain coverage under this general permit or, alternatively, require an application for an *individual SPDES permit*.

Additional Information

1. A site map showing topography (or indicating the outline of drainage areas served by the *outfall(s)* for which *discharge* authorization and permit coverage is being sought if a topographic map is unavailable) of the facility including: each of its drainage and *discharge* structures; the drainage area of each *stormwater outfall*; paved areas and buildings within the drainage area of each *stormwater outfall*; areas used for outdoor storage or disposal of *significant materials*; structural *control measure(s)* to reduce *pollutants* in *stormwater* runoff; material loading and access areas; areas where pesticides, herbicides, soil conditioners and fertilizers are applied; each hazardous waste treatment, storage or disposal facility (including each area not required to have a RCRA permit which is used for accumulating hazardous waste under 40 CFR 262.34); wells where fluids from the facility are injected underground; and springs, and surface and/or *groundwater* bodies which will receive *stormwater discharges* from the facility.
2. An estimate of the area of impervious surfaces (including paved areas and building roofs) and the total area drained by each *outfall* and a narrative description of the following: *significant materials* that, in the three years prior to the submittal of this information, have been treated, stored or disposed of in a manner which will allow exposure to *stormwater*; methods of treatment, storage or disposal of such materials; materials management practices employed to *minimize* contact of these materials with *stormwater* runoff; materials loading and access areas; the location, manner and frequency of application of pesticides, herbicides, soil conditioners and fertilizers; the location and description of structural and non-structural *control measures* being used to reduce *pollutants* in *stormwater* runoff; and a description of the *stormwater* treatment, including the ultimate disposal of any solid or fluid wastes other than by *discharge*.

3. A certification that all *outfalls* that could contain *stormwater discharges associated with industrial activity* have been tested or evaluated for the presence of non-*stormwater discharges* which are not covered by an existing *SPDES* permit; tests for such non-*stormwater discharges* may include smoke tests, fluorometric, analysis of accurate schematics, as well as other appropriate tests. The certification shall include a description of the method used, the date of any testing, and the on-site drainage points that were directly observed during a test.
4. Existing information regarding reportable leaks or spills of toxic or hazardous *pollutants* at the facility that have occurred within the three years prior to the submittal of this information.
5. Estimates for the following parameters for all *outfalls*:
 - Any *pollutant* limited in an effluent limitations guideline for which the facility is subject;
 - Any *pollutant* listed in the facility's existing *SPDES* permit, if any;
 - Oil and grease, pH, BOD5, COD, TSS, total phosphorus, Ammonia, Total Kjeldahl nitrogen, and nitrate plus nitrite nitrogen;
 - Any information on the *discharge* required under paragraph §122.21(g)(7)(iii) and (iv) of 40 CFR Part 122; and
 - The flow rate and total amount of *discharge* for *stormwater* event(s) and the method of estimation.
6. Other information as the *Department* may reasonably require to determine whether coverage under this general permit or, alternatively, under an individual permit is required.

Appendix F - List of DEC Regional Offices

List of NYS DEC Regional Offices			
Region	Counties Covered	DIVISION OF ENVIRONMENTAL PERMITS (DEP) Permit Administrators	DIVISION OF WATER (DOW) Water (SPDES) Program Regional Water Engineer
1	Nassau and Suffolk	SUNY @ Stony Brook 50 Circle Road Stony Brook, NY 11790-3409 Tel. (631) 444-0365	SUNY @ Stony Brook 50 Circle Road Stony Brook, NY 11790-3409 Tel. (631) 444-0405
2	Bronx, Kings, New York, Queens and Richmond	1 Hunters Point Plaza, 47-40 21st St. Long Island City, NY 11101-5407 Tel. (718) 482-4997	1 Hunters Point Plaza, 47-40 21st St. Long Island City, NY 11101-5407 Tel. (718) 482-4933
3	Dutchess, Orange, Putnam, Rockland, Sullivan, Ulster and Westchester	21 South Putt Corners Road New Paltz, NY 12561-1696 Tel. (845) 256-3059	100 Hillside Ave., Suite 1W Whiteplains, NY 10603-2860 Tel. (914) 428-2505
4	Albany, Columbia , Delaware , Greene , Montgomery, Otsego, Rensselaer, Schenectady and Schoharie	1130 North Westcott Road Schenectady, NY 12306-2014 Tel. (518) 357-2069	1130 North Westcott Road Schenectady, NY 12306-2014 Tel. (518) 357-2045
5	Clinton, Essex, Franklin, Fulton, Hamilton, Saratoga, Warren and Washington	1115 NYS Route 86 Ray Brook, NY 12977-0296 Tel. (518) 897-1234	232 Golf Course Road Warrensburg, NY 12885-0220 Tel. (518) 623-1200
6	Herkimer, Jefferson, Lewis, Oneida and St. Lawrence	State Office Building 317 Washington Street Watertown, NY 13601-3787 Tel. (315) 785-2245	State Office Building 207 Genesee Street Utica, NY 13501-2885 Tel. (315) 793-2554
7	Broome , Cayuga , Chenango, Cortland, Madison, Onondaga, Oswego, Tioga and Tompkins	615 Erie Blvd. West Syracuse, NY 13204-2400 Tel. (315) 426-7438	615 Erie Blvd. West Syracuse, NY 13204-2400 Tel. (315) 426-7500
8	Chemung, Genesee, Livingston, Monroe, Ontario, Orleans, Schuyler, Seneca, Steuben, Wayne and Yates	6274 East Avon-Lima Road Avon, NY 14414-9519 Tel. (585) 226-2466	6274 East Avon-Lima Rd. Avon, NY 14414-9519 Tel. (585) 226-2466
9	Allegany, Cattaraugus, Chautauqua, Erie, Niagara and Wyoming	270 Michigan Avenue Buffalo, NY 14203-2999 Tel. (716) 851-7165	270 Michigan Ave. Buffalo, NY 14203-2999 Tel. (716) 851-7070

Appendix G – Pollutant(s) of Concern for Impaired Waterbodies Reference Table

Pollutant(s) of Concern for Impaired Waterbodies Reference Table		
Pollutant of Concern Causing Impairment	Applicable Benchmark or Numeric Effluent Limit	Sector
Acid/Base (pH)	pH	A, D, E, G, I, J, K, L, S
Algal/Plant Growth	Total Nitrogen (TN)	A, C, J, K, L, S, U, Z, AA
	Total Phosphorous (TP)	C, J, L, U
	Total Suspended Solids (TSS)	A, D, E, F, G, I, J, K, L, M, N, U, AC
Ammonia	Total Nitrogen (TN)	A, C, J, K, L, S, U, Z, AA
	Ammonia	K, L, S
	Nitrogen	S
Biological Impacts	Aluminum	C, E, F, M, N, Q, AA
	Arsenic	A, G, K
	Cadmium	G, K, N
	Beryllium	G
	Chromium	A, K, N, Z
	Copper	A, F, G, N, AC
	Cyanide	K
	Iron	C, E, F, G, J, L, M, N, O, Q, AA
	Lead	C, G, K, M, N, Q, AC
	Magnesium	K
	Manganese	G
	Mercury	G, K, N
	Nickel	G
	Selenium	G, K
	Silver	G, K
	Zinc	A, C, F, G, J, K, L, N, Q, Y, AA
	Chlorides	I
	Total Nitrogen (TN)	A, C, J, K, L, S, U, Z, AA
	Total Phosphorous (TP)	C, J, L, U
	Total Suspended Solids (TSS)	A, D, E, F, G, I, J, K, L, M, N, U, AC

Pollutant(s) of Concern for Impaired Waterbodies Reference Table (Continued)

Pollutant of Concern Causing Impairment	Applicable Benchmark or Effluent Limit	Sector
Cadmium	Cadmium	G, K, N
Chlorides/Salts	Chlorides	I
Copper	Copper	A, F, G, N, AC
Cyanide	Cyanide	K
Floatables	Oil & Grease	C, D, M, N, O, P
Mercury	Mercury	G, K, N
Harmful Algal Blooms	Total Nitrogen (TN)	A, C, J, K, L, S, U, Z, AA
	Total Phosphorous (TP)	C, J, L, U
	Total Suspended Solids (TSS)	A, D, E, F, G, I, J, K, L, M, N, U, AC
Low D.O./ Oxygen Demand	Biochemical Oxygen Demand (BOD)	K, L, S, U
	Chemical Oxygen Demand (COD)	A, B, G, K, N, P, S, T, U
	Total Nitrogen (TN)	A, C, J, K, L, S, U, Z, AA
	Total Phosphorous (TP)	C, J, L, U
Nitrogen	Total Nitrogen (TN)	A, C, J, K, L, S, U, Z, AA
Nutrients	Total Nitrogen (TN)	A, C, J, K, L, S, U, Z, AA
	Total Phosphorous (TP)	C, J, L, U
	Total Suspended Solids (TSS)	A, D, E, F, G, I, J, K, L, M, N, U, AC
PCBs	PCBs	N, O
Phosphorus	Total Phosphorous (TP)	C, J, L, U
	Total Suspended Solids (TSS)	A, D, E, F, G, I, J, K, L, M, N, U, AC
Oil & Grease	Oil & Grease	C, D, M, N, O, P
Silt/Sediment	Total Suspended Solids (TSS)	A, D, E, F, G, I, J, K, L, M, N, U, AC
Turbidity	Total Suspended Solids (TSS)	A, D, E, F, G, I, J, K, L, M, N, U, AC

Appendix H – Standard Permit Conditions

1. Duty to Comply

The *owner or operator* must comply with all terms and conditions of the permit. Any permit noncompliance constitutes a violation of the *Environmental Conservation Law* and is grounds for enforcement action, ineligibility for this SPDES general permit, or denial of a permit renewal.

An owner/operator's filing of a request for a transfer or termination, or notification of planned changes or anticipated non-compliance does not limit, diminish or stay compliance with any terms of this general permit.

2. Continuation of the Expired General Permit

In the event a new general permit is not issued prior to the expiration of this general permit and this general permit is extended pursuant to the State Administrative Procedure Act and 6 NYCRR Part 621, then the *owner or operator* with coverage under this general permit may continue to operate and *discharge* in accordance with the terms and conditions of this general permit until such time that a new general permit is issued. This general permit expires 5 years from the effective date.

3. Enforcement

Failure of the *owner or operator* to strictly adhere to any of the SPDES general permit requirements contained herein shall constitute a violation of this SPDES general permit. There are substantial criminal, civil, and administrative penalties associated with violating the provisions of this SPDES general permit. Fines of up to \$37,500 per day for each violation and imprisonment for up to fifteen (15) years may be assessed depending upon the nature and degree of the offense.

4. Need to Halt or Reduce Activity Not a Defense

It shall not be a defense for an *owner or operator* in an enforcement action that it would have been necessary to halt or reduce the permitted activity in order to maintain compliance with the conditions of this permit.

5. Duty to Mitigate

The *owner or operator* shall take all reasonable steps to *minimize* or prevent any *discharge* in violation of this permit which has a reasonable likelihood of adversely affecting human health or the environment.

6. Duty to Provide Information

The *owner or operator* shall furnish to the *Department*, within five (5) business days of a *Department* request for such information, any information requested to determine compliance with this SPDES general permit, or to determine whether cause exists for denying coverage in accordance with Appendix H.13 of this general permit. The *owner or operator* shall also furnish upon request, copies of records required by this permit.

7. Other Information

When the *owner or operator* becomes aware that they failed to submit any relevant facts or submitted incorrect information in the NOI or in any report to the *Department*, they shall promptly submit corrected facts or information.

8. Signatory Requirements

a. All forms (NOI and NOT), shall be signed as follows:

(1) For a corporation: by a responsible corporate officer. For the purpose of this section, a responsible corporate officer means:

(a) a president, secretary, treasurer, or vice-president of the corporation in charge of a principal business function, or any other person who performs similar policy or decision-making functions for the corporation; or

(b) the manager of one or more manufacturing, production or operating facilities, provided, the manager is authorized to make management decisions which govern the operation of the regulated facility including having the explicit or implicit duty of making major capital investment recommendations, and initiating and directing other comprehensive measures to assure long term environmental compliance with environmental laws and regulations; the manager can ensure that the necessary systems are established or actions taken to gather complete and accurate information for permit application requirements, and where authority to sign documents has been assigned or delegated to the manager in accordance with corporate procedures.

b. For a partnership by a general partner

c. For a sole proprietorship by the proprietor,

d. For a municipality: State, Federal, or other public agency: by either a principal executive officer or ranking elected official. For purposes of this section, a principal executive officer of a Federal agency includes (1) the chief executive officer of the agency, or (2) a senior executive officer having responsibility for the overall operations of a principal geographic unit of the agency (e.g. Regional Administrators of EPA).

e. Duly Authorized Representatives

All reports and documentation required by the permit and other information requested by the *Department* shall be signed by a person described above or by a duly authorized representative of that person. A person is a duly authorized representative only if:

(1) The authorization is made in writing by a person described above and submitted to the *Department*.

(2) The authorization specifies either an individual or a position having responsibility for the overall operation of the regulated facility or activity, such as the position of

manager, *owner or operator*, superintendent, or position of equivalent responsibility or an individual or position having overall responsibility for environmental matters for the company. (A duly authorized representative may thus be either a named individual or any individual occupying a named position).

f. Changes to authorization

If an authorization under Appendix H.8.a is no longer accurate because a different individual or position has responsibility for the overall operation of the facility, a new authorization satisfying the requirements above must be submitted to the *Department* prior to or together with any reports, information, or applications to be signed by an authorized representative.

g. Certification

Any person signing documents under this section shall make the following certification: "I certify under penalty of law that this document and all attachments were prepared under my direction or supervision in accordance with a system designed to assure that *qualified personnel* properly gathered and evaluated the information submitted. Based on my inquiry of the *person or persons* who manage the system, or those *person* directly responsible for gathering the information, the information submitted is, to the best of my knowledge and belief, true, accurate, and complete. I am aware that there are significant penalties for submitting false information, including the possibility of fine and imprisonment for knowing violations.

9. Penalties for Falsification of Documentation/Penalties related to Monitoring Devices

In accordance with 6 NYCRR 750-2.4 and 750-2.5, any person who knowingly makes any false material statement, representation, or certification in any application, record, report or other document filed or required to be maintained under this permit, including monitoring reports or reports of compliance or noncompliance shall, upon conviction, be punished in accordance with ECL §71-1933 and or Articles 175 and 210 of the New York State Penal Law.

10. Oil and Hazardous Substance Liability

Nothing in this permit shall be construed to preclude the institution of any legal action or relieve the *owner or operator* from any responsibilities, liabilities, or penalties to which the *owner or operator* is or may be subject under section 311 of the CWA or section 102 of the Comprehensive Environmental Response, Compensation and Liability Act of 1980 ("CERCLA").

11. Property Rights

The issuance of this permit does not convey any property rights in either real property or personal property, nor any exclusive privileges, nor does it authorize any injury to private property nor any invasion of personal rights, nor any infringement of Federal, *State* or local laws or regulations; nor does it obviate the necessity of obtaining the assent of any other jurisdiction as required by law for the authorized *discharge*. Owners or Operators must obtain any applicable conveyances, easements, licenses and/or access to real property prior to commencing *discharges* authorized by this SPDES general permit.

12. Severability

The provisions of this permit are severable, and if any provision of this permit, or the application of any provision of this permit to any circumstance, is held invalid, the application of such provision to other circumstances, and the remainder of this permit shall not be impaired or affected thereby.

13. Requiring an Individual Permit or an Alternative General Permit

The *Department* may require any person authorized by this general permit to apply for and/or obtain either an *individual SPDES permit* or an alternative *SPDES general permit* in accordance with 6 NYCRR Part 750-1.21(e).

- a. The *Department* may require any *owner or operator* authorized by this permit to apply for and/or obtain either an *individual SPDES permit* or another *SPDES general permit*. When the *Department* requires any *discharger* authorized by a general permit to apply for an *individual SPDES permit*, it shall notify the *discharger* in writing that a permit application is required. This notice shall include a brief statement of the reasons for this decision, an application form, a statement setting a time frame for the *owner or operator* to file the application for an *individual SPDES permit*, and a deadline, not sooner than 180 days from *owner or operator* receipt of the notification letter, whereby the authorization to *discharge* under this general permit shall be terminated. Applications must be submitted to the appropriate Permit Administrator at the Regional Office. The *Department* may grant additional time upon demonstration, to the satisfaction of the *Department*, that additional time to apply for an alternative authorization is necessary or where the *Department* has not provided a permit determination in accordance with Part 621 of this Title.
- b. When an *individual SPDES permit* is issued to a *discharger* authorized to *discharge* under a general *SPDES permit* for the same *discharge(s)*, the general permit authorization for *outfalls* authorized under the *individual SPDES permit* is automatically terminated on the effective date of the individual permit unless termination is earlier in accordance with 6 NYCRR Part 750.

14. State/Environmental Laws

- a. Nothing in this permit shall be construed to preclude the institution of any legal action or relieve the *owner or operator* from any responsibilities, liabilities, or penalties established pursuant to any applicable *State* law or regulation under authority preserved by section 510 of the Clean Water Act.
- b. No condition of this permit shall release the *owner or operator* from any responsibility or requirements under other environmental statutes or regulations.
- c. Nothing in this *SPDES general permit* relieves the *Owner or Operator* from the requirement to obtain any other permits required by law.
- d. Coverage under this *SPDES permit* does not supersede, revoke or rescind an order on consent or modification of the order or any of the terms, conditions or requirements contained in such order or modification unless specifically intended by the order or a newly issued order.

15. Proper Operation and Maintenance

The *owner or operator* shall at all times properly operate and maintain all facilities and systems of treatment and control (and related appurtenances) which are installed or used by the *owner or operator* to achieve compliance with the conditions of this permit and with the requirements of *stormwater* pollution prevention plans. Proper operation and maintenance also includes adequate laboratory controls and appropriate quality assurance procedures. Proper operation and maintenance requires the operation of backup or auxiliary facilities or similar systems installed by an *owner or operator* only when necessary to achieve compliance with the conditions of the permit.

16. Inspection and Entry

The *owner or operator* shall allow an authorized representative of either the *Department* or EPA or, in the case of a facility which *discharges* through a *municipal separate storm sewer system*, an authorized representative of the municipal operator of the separate storm sewer receiving the *discharge*, upon the presentation of credentials and other documents as may be required by law, to:

- a. Enter upon the *owner or operators* premises where a regulated facility or activity is located or conducted or where records must be kept under the conditions of this permit;
- b. Have access to and copy at reasonable times, any records that must be kept under the conditions of this permit, including required to be maintained for the purposes of operation and maintenance:
- c. Inspect at reasonable times any facilities or equipment (including monitoring and control equipment), practice or operations regulated or required under the permit; and
- d. Sample or monitor, at reasonable times, for the purposes of assuring permit compliance or as otherwise authorized the CWA or the ECL, any substance or parameters at any location.

17. Definitions

Definitions are included in Appendix A of this permit. Additional definitions are provided within the Part VII industrial sectors for terms that are specific to those industries.

18. Reopener Clause

- a. If there is evidence indicating potential or realized impacts on water quality due to any *stormwater discharge associated with industrial activity* covered by this permit, the *owner or operator* of such *discharge* may be required to obtain an individual permit or an alternative general permit in accordance with Appendix H.13 of this permit or the permit may be modified to include different limitations and/or requirements.
- b. Permit modification, suspension, or revocation will be conducted according to 6 NYCRR Part 621 and 6 NYCRR 750-1.18 and 750-1.20.



APPENDIX H

NON-STORMWATER DISCHARGE CERTIFICATION



Non-Stormwater Discharge Certification

Facility: It's Greener Now, Inc. – Padua Ridge Gravel Mine

Date of Evaluation: _____

Date of last precipitation: _____

Describe evaluation criteria or testing method:

Visual: Outfalls were observed for discharge after four (4) days of no precipitation.

List of outfalls observed during the evaluation:

Outfall 001: Overflow from the emergency spillway of the stormwater management area.

Outfall 002: Discharge from facility entrance vicinity via catch basin system.

Description of results of tests/evaluation:

Outfall 001: Yes, discharge observed. No, no discharge observed.

Outfall 002: Yes, discharge observed. No, no discharge observed.

If discharge observed, identify potential significant sources of non-stormwater:

Outfall 001: _____

Outfall 002: _____

“I certify that the information provided on this Non-Stormwater Discharge Certification is true and accurate.”

Print Name: _____ Signature: _____

Title: _____ Date: _____



APPENDIX I

NOTICE OF INTENT (NOI)



Department of Environmental Conservation

Notice of Intent

GP-0-17-004

This is the Notice of Intent for Stormwater Discharges Associated with Industrial Activity under the State Pollutant Discharge Elimination System (SPDES) Multi-Sector General Permit GP-0-17-004.

The completed Notice of Intent (NOI) should be submitted to:

MSGP Coordinator,
NYSDEC Division of Water,
625 Broadway, 4th Floor
Albany, New York 12233-3505

For Department Use Only

NYR

Save time by filing your NOI electronically using the E-NOI found on the Departments website

IMPORTANT

- Applicants must read and understand the conditions of the permit prior to submitting this NOI Form.
- Applicants are responsible for identifying and obtaining other DEC permits that may be required.
- Use this NOI to obtain coverage under GP-0-17-004 OR to make revisions to a previously submitted NOI.
- All sections must be completed unless otherwise noted. Incomplete forms will be returned to you, thereby delaying your coverage under this General Permit.
- Type or print in boxes. Avoid contact with the edge of the boxes.
- Fill in circles completely and do not use check marks.
- The Owner/Operator must sign the NOI.

SECTION 1

Owner/Operator Information

Federal Tax ID #

2 2 - 3 7 6

Enter the name of the legally responsible entity and the address of the executive office.

O/O Name

I T ' S G R E E N E R N O W , I N C .

O/O Street Address

3 3 6 2 R O U T E 4 0 9

O/O City

W A T K I N S G L E N

O/O State

N Y

O/O Zip

1 4 8 9 1 -

Contact Information

Enter the name and contact information for the individual responsible for communicating with DEC regarding the implementation of the MSGP on behalf of the owner/operator.

Contact First Name

M A R T I N

Contact Last Name

W O J C I K

Contact Phone

6 0 7 - 5 3 5 - 5 5 2 5

Contact eMail

p a d u a r i d g e @ y a h o o . c o m

Facility Information

Enter the complete street address of the physical location of the facility.

Facility Name

P A D U A R I D G E G R A V E L M I N E

Facility Street Address

3 3 6 2 R O U T E 4 0 9

Facility City

W A T K I N S G L E N

State Facility Zip

N Y 1 4 8 9 1 -

Facility County

S C H U Y L E R

Provide the geographic coordinates in decimal degrees for the latitude & longitude of the facility. The NYSDEC Stormwater Interactive Map on the DEC's website can be used to get coordinates.

Go to: www.dec.ny.gov/imsmaps/stormwater/viewer.htm

4 2 . 3 7 6 0 6 3 - 7 6 . 8 8 1 6 0 6

Latitude

Longitude

Billing Information

- Billing information is same as Owner/Operator (Do not complete this section)
- Billing information is different from Owner/Operator (Please complete billing information below)

Name

Street Address

City

State Zip

-

7(a). Has this facility been assigned a SPDES MSGP ID under previous versions of the MSGP? Yes No
 If No, go to question 8.

7(b). If Yes, Provide the ID if known (Note: All SPDES MSGP IDs begin with NYR00)

The facility's existing ID is:

N	Y	R	0	0				
---	---	---	---	---	--	--	--	--

SECTION 3

8. Does this facility have coal piles that are exposed to precipitation? Yes No

9. Does this facility have salt piles that are exposed to precipitation? Yes No

10. Does this facility discharge stormwater from secondary containment areas for liquid bulk storage or transfer areas? Yes No

11. SECTOR S - Is this facility an airport that uses more than 100,000 gallons of glycol-based deicing/anti-icing chemicals and/or 100 tons or more of urea on an average annual basis? Yes No

12. Is a Representative Outfall Waiver being claimed in accordance with Part IV.G?
 (If Yes, please submit the Representative Outfall waiver form with the NOI). Yes No

13. For each stormwater discharge associated with industrial activity at your facility identify the outfall number (e.g., 001, 002, etc.); the four digit Standard Industrial Classification (SIC) codes, the Sector Code, the Sector N Subsector, or 2-letter Industrial Activity Codes that best represent the principal products or services rendered by the facility for that drainage area; and the Benchmark (B) and/or Compliance (C) monitoring required; and the acreage of industrial activity exposed to stormwater for each outfall (round to nearest tenth of an acre):

Industrial Activities (SIC or 2-letter Codes)

Outfall Number	Primary SIC	Sector	Monitoring Required	Secondary SIC	Sector	Monitoring Required	Tertiary SIC	Sector	Monitoring Required	Acreage
0 0 1	1 4 4 2	J	B C							0 5 3 . 8
0 0 2	1 4 4 2	J	B C							0 1 1 . 0
Total Acreage										



APPENDIX J

ANALYTICAL LABORATORY RESULTS



APPENDIX K

WEEKLY INSPECTION FORM

CONSTRUCTION INSPECTION

To be used for weekly inspections and final construction inspection.

Inspector: _____ Date of Inspection: _____

I, _____, the undersigned, certify that, to the best of my knowledge, all information provided on the following inspection form is accurate and complete.

Dated: _____ Signature: _____

Weekly Inspection

Final Inspection

MAINTENANCE ITEM	STATUS*	COMMENTS
SILT FENCE		
Installation compliance		
Proper spacing		
No tears/rips/fallen sections		
Sediment build-up		
Stakes vertical		
CONSTRUCTION ACCESS		
Evidence of tracking		
Vehicles are only using this access		
Adequate access length		
Site graded away from access		
SEDIMENT TRAPS/ PONDS		
Seepage/leaks out of pond		
Sediment accumulation		
Gravel weir condition		
Water flows only over weir		
OUTLET PROTECTION		
Sediment depth		
Erosion of downstream reach		
DIVERSION		
Stabilized		
Positive drainage to outlet		
Sediment depth		
STAGING AREAS		
Silt fence/hay bale adequate		

* S=Satisfactory M=Marginal U=Unsatisfactory

NOTES:



APPENDIX H

NYSDEC DEIS FINAL SCOPING OUTLINE

New York State Department of Environmental Conservation

Division of Environmental Permits, Region 8

6274 East Avon-Lima Road, Avon, New York 14414-9519

Phone: (585) 226-5400 • FAX: (585) 226-2830

Website: www.dec.ny.gov



Alexander B. Grannis
Commissioner

August 18, 2008

By FAX and Regular Mail

Marty Wojcik

It's Greener Now, Inc.

3362 NYS State Route 409

Watkins Glen, New York 14891

RE: Final Scope Outline for Draft Environmental Impact Statement
Application to Expand Life of Mine
Application ID 8-54424-00006/00001, MLR 80244
It's Greener Now Inc. - Padua Gravel Pit
(T) Dix, Schuyler County

Dear Mr. Wojcik:

Enclosed is the Final Scope Outline for the Draft Environmental Impact for the above-referenced project. The Final Scope Outline has been modified from the Draft Scoping Outline which was sent out on June 19, 2008. The changes made to the Draft Scope Outline reflect new information and concerns received during the public comment period.

The Department as lead agency would be the point of contact to facilitate meetings with agencies or interested parties to coordinate the information gathering necessary for the development of the dEIS document.

The application remains incomplete until a determination is made that the dEIS is adequate.

Please contact me at 585-226-5390 or email at palent@gw.dec.state.ny.us if you have any question relating to the status of the application, the information in the Scope Outline, or the environmental review process. Thank you for your time and assistance in the matter.

Sincerely,

Peter A. Lent

Regional Permit Administrator

cc: By E-Mail or Regular Mail

Supervisor, Town of Dix
Mayor, Village of Watkins Glen

Mr. James E. Clements, NYSDOT Hornell
Ms. Sue Poelvoorde, OPRHP, Trumansburg
Mr. Thomas Lyons, OPRHP Albany
Ms. Kate Bartholomew, Schuyler County EMC
Ms. Stacy B. Husted, Clerk, Schuyler County Legislature
Mr. Edward Bugliosi, Chief, Ithaca Office, USGS New York Water Science Center
Mr. Kevin Bernstein, Esq, Bond, Shoeneck, & King PLLC (by E-mail & Regular Mail)
Mr. Leo Bracci Esq.
Mr. Roger McDonough
Mr. Steven Army
Mr. Joseph Bucci
Mr. Lawrence Weintraub Esq.
Mr. William Adriance

DRAFT ENVIRONMENTAL IMPACT STATEMENT (dEIS) FINAL SCOPING OUTLINE

It's Greener Now (IGN), Inc.
Padua Pit
DEC 8-4424-00006/00001
MLR 80244

1.0 COVER SHEET. Type of document (draft, final), title of project, location, name and address of Lead Agency, name and telephone number of Lead Agency contact person, name and address of document preparer and deadline for acceptance of public and agency comments.

2.0 TABLE OF CONTENTS

3.0 INTRODUCTION. The dEIS will discuss the identified environmental issues for the project. These issues will be presented and discussed, as described below.

► Project Description.

The applicant proposes to expand current surface sand and gravel mining operations, from 14.33 to 106.27 acres, on properties which total 281 acres. The mine is intended to continue to operate as a traditional surface extraction of unconsolidated sand and gravel, and will not involve removal of consolidated bedrock.

The modification to expand the Life of Mine (LOM) area from 14.33 acres to 106.27 acres will not result in a significant change from previously permitted historic operations. While the overall acreage of the mine will increase over the life of the project, the active mining excavation area, previously mined unreclaimed areas, and processing areas will not exceed 15 acres at any one time. In addition to these areas, affected acreage at this facility has historically included an office and scale house area which will continue to be part of the operation, and the applicant has proposed the addition of a rail spur loading area. Concurrent reclamation will be performed throughout the life of the operation to control the number of affected acres. As operations progress, there will not be a significant increase in the mine's production rate. The existing mine area currently abuts the Watkins Glen State Park property, and will continue to do so as the mine expands. However, as operations expand, mining excavation operations will be moving further away from the Watkins Glen gorge. The expanded life of mine area will serve to increase the available sand and gravel reserves.

Mining is not proposed below the local water table. Excavation will be done by mechanical equipment, standard for sand and gravel mining operations. Mining is proposed to remove approximately 10 million cubic yards of sand and gravel over the estimated 20 year operational life of the mine. Mined material will continue to be processed with screening, washing, and crushing equipment. Sorted aggregate will be stockpiled in locations indicated on the Mining Plans. The maximum processing rate for the screening and washing plant is 560 tons per hour, and for the crushing plant is 290 tons per hour. Final reclamation of the site will include grading and sloping of all mine faces, the replacement of stockpiled topsoil, and re-seeding with an approved seed mixture. The reviewed life-of-mine area is 106.27 acres. The applicant proposes to operate the mine 7 days a week, 5:00 AM to 7:00 PM Monday through Friday, and 8:00 AM to 5:00 PM Saturday and Sunday for truck loading only.

- ▶ **Executive Summary.** This summary will present an overview of the project, provide a brief description of the overall proposed action, and list the following:
 - ▶ significant beneficial and adverse impacts,
 - ▶ alternatives considered,
 - ▶ mitigation measures proposed,
 - ▶ issues of controversy, and
 - ▶ matters to be decided, including a list of each permit or approval required.
- ▶ **Purpose And Need For The Proposed Action.** The dEIS will discuss the purpose, need and public benefit of the proposed project.

3.1 ENVIRONMENTAL REVIEW PROCESS

- ▶ **Uniform Procedures Regulations.** In New York State, processing of environmental permit applications is regulated by 6 NYCRR Part 621, Uniform Procedures Regulations. The intent of the Uniform Procedures Regulations is to ensure timely review of projects requiring multiple environmental permits. Projects subject to the State Environmental Quality Review Act (SEQR) regulations must satisfy these requirements before permit applications reviewed under Part 621 are deemed complete. When the NYSDEC as the lead agency determines that a draft EIS is required by the applicant, the scoping, review and acceptance of the dEIS are considered a prerequisite to a complete permit application.

Table 1.0 provides an overview of the permits and approvals presently anticipated to be necessary for the proposed project, the agencies responsible for the approvals and the applicable law or regulations associated with each approval. This table may be revised as additional information is developed in the course of the scoping process.

- ▶ **State Environmental Quality Review.** The SEQR Act and its implementing regulations require agencies to assess potential environmental impacts of proposed projects during the permitting process. Under SEQR, the primary means of assessment is a dEIS.

A dEIS is intended to function as a disclosure document to reveal information about the expected environmental effects of the proposed action and provide a basis for informed decisions. The dEIS identifies and addresses the potential environmental impacts of a project and reasonable alternatives, if any, and identifies ways to avoid or mitigate any potential adverse impacts to the maximum extent practicable. Also addressed are irreversible and irretrievable commitments of resources, growth inducing aspects, and the use and conservation of energy.

The dEIS must be written to a level of detail to properly assess the impacts identified and which allows an agency to make a reasoned decision on the action. Many of the issues will also be reviewed in accordance with NYS statutory requirements relating, for example, to the mineral resources permit program. In general, the dEIS will follow the content requirements of SEQR, 6 NYCRR Part 617.9(b) Environmental Impact Statement Content.

- ▶ **EIS Scoping Process.** The primary goals of scoping are to focus the dEIS on potentially

significant adverse impacts and to eliminate consideration of those impacts that are irrelevant or non-significant. The scoping process establishes the content of a dEIS, and the lead agency provides the public the opportunity to participate in that process. The final scoping document will be completed after consideration of all substantive comments from the public and involved agencies.

- ▶ **Opportunities For Public Comment.** In addition to seeking public input on its scope, the dEIS, when completed and accepted by NYSDEC, will be made available for public review and comment. A Public Hearing will be held by the NYSDEC to receive public comment on the dEIS. A final EIS will then be prepared to address all substantive comments received. The dEIS and supporting documents must be available in an electronic format and posted on the web to enable public review.

4.0 ENVIRONMENTAL SETTING, SIGNIFICANT ENVIRONMENTAL IMPACTS, AND MITIGATION MEASURES TO MINIMIZE ENVIRONMENTAL IMPACTS.

The environmental setting of the proposed project will be described. Impacts of the proposed project will be evaluated. For each environmental issue, the dEIS will discuss present conditions; the short-term, long-term and cumulative environmental impacts anticipated to result from project development including those that cannot be avoided or adequately mitigated; alternatives; and mitigation measures to be incorporated into the project to minimize its impact. If beneficial impacts are identified, they will be described in a similar manner. In general, the dEIS will follow the content requirements of SEQR, Part 617.9(b). This dEIS will focus on identifying environmental issues, their analysis and the evaluation of alternatives related to the expansion of a currently permitted sand and gravel mine. Specific topics to be addressed are discussed below.

- ▶ **Geologic Resources**

Buried Gorges

There have been reports that paleo-gorges are present on or in the vicinity of the area of the current mine and the proposed mine expansion. Paleo-gorges are bedrock channels which are considered glacial features. They are also called buried gorges because they have been filled with unconsolidated material deposited by the glaciers.

A. Existing Environmental Setting: A more complete description of the nature, location and extent of the buried gorges will be provided. Additional hydrogeological information/data (e.g. new borings/wells) should be provided to supplement the available information to better characterize the unconsolidated material within the gorges, the bedrock channels forming the gorges, and the hydrologic conditions within the unconsolidated material and bedrock associated with the buried gorges in the vicinity of the common property boundary between the mine and the Watkins Glen State Park. The discussion of existing hydrologic flow patterns associated with the buried gorges should describe sources of infiltration from areas in and around the buried gorges and any connectivity between the buried gorges and Glen Creek. This should include the areas north of the railroad trestle in the vicinity of Punchbowl Lake, the seeps and springs along the north rim and north wall of the Glen Creek Gorge, as well as the seeps and springs on the hillside within the Village of Watkins Glen, which are located northeast and east of the area to be mined. A graphical representation, both in plan and profile view, of the

location and the extent of the buried gorges in relationship to the mine and the Watkins Glen State Park should be included in the dEIS. The areas depicted in the graphical representation of the buried gorges will include the head areas of the buried gorge(s) where they are in close proximity to the Glen Creek channel, which is north of the railroad trestle and near the area called Punchbowl Lake, and the discharge locations of the historic mineral springs which were associated with the former Glen Springs Hotel.

B. Potential Impacts:

The dEIS should describe in detail the extent to which mining activities will disturb the areas where the buried gorges are located, including: the extent to which the material filling the gorges will be mined and the potential impacts of mining on hydrologic conditions in the buried gorges related to changes to the amount and rate of infiltration and water used for processing material at the mine.

The dEIS should investigate the extent to which the channels of the buried gorges may influence the hydrology of the Watkins Glen State Park and the Glen Creek gorge. The current and newly collected hydrogeological information should be used in this evaluation.

The dEIS should also investigate and discuss the potential impacts the proposed mining activities may have on the hydrological conditions and flow patterns associated with the buried gorges and how these impacts may affect the hydrology of Glen Creek and the Watkins Glen State Park, and nearby areas northeast and east of the mine property.

C. Proposed Mitigation Measures. Measures to avoid and minimize potentially significant adverse changes to existing hydrologic conditions associated with the buried gorges, which may affect the hydrology of offsite areas, such as Glen Creek, Watkins Glen State Park, and residential areas northeast and east of the IGN property, will be identified and discussed.

- ▶ **Ecological Resources.** It is unlikely that this proposed expansion will have any significant adverse impact upon fish and wildlife resources occurring on the mine site and no further analysis is anticipated as part of the dEIS. Watkin's Glen State Park and the Glen Creek gorge will be the focus of future work as described below.

A. Existing Environmental Setting. Within the areas of Watkins Glen State Park and the Glen Creek gorge, which are located south and east of the proposed mine expansion site, the presence of any water dependent endangered or threatened species, species of Special Concern, species of greatest conservation need (SGCN) or significant habitats, will be identified through literature reviews, site surveys and consultation with NYSDEC personnel, US Fish & Wildlife Service, and NYS Office of Parks Recreation and Historic Preservation.

The level of analyses expected of the applicant will be dependent upon the availability of information in existing published scientific and natural history literature, NYS DEC data (where available), status and trends reports, life history accounts, and other appropriate sources of information. In the absence of such information or if such information is inconclusive, the applicant will be required to conduct additional site- and project-specific studies to assess potential impact from the project.

B. Potential Impacts. The dEIS will evaluate potential impacts as a result of the mining operations to the flora and fauna of Watkins Glen State Park and their preferred habitats that

are dependent upon the Park's hydrology (i.e. groundwater seeps, springs, or surface water channels) for their existence.

C. Proposed Mitigation Measures. Measures to preserve or enhance existing wildlife habitat, as appropriate, will be identified and discussed.

► **Water Resources**

Groundwater

A. Existing Environmental Setting. Existing groundwater resources, both in unconsolidated (deltaic) sediments and consolidated bedrock, within the mining area and adjacent areas of Watkins Glen State Park, south and east of the mining area, will be identified and described.

Information available on the existing glacial and bedrock stratigraphy and water levels within these units will need to be supplemented by additional data (e.g. new borings/wells) from south and east of the common boundary between the mining area and the Watkins Glen State Park.

Contour maps showing hydraulic heads (water table) in both bedrock aquifer and deltaic, unconfined aquifer should be provided from data collected from the geologic units where mining will take place as well as from information collected from areas located east and south of the IGN property within the Watkins Glen State Park.

The proposed mining plan is to only remove gravel from above the water table. A fivefoot separation between the water table and the mine floor would be required. Currently there is insufficient data available about the annual fluctuation of the water table elevation in both deltaic and bedrock aquifers to determine where the lower limits of mining should be. All water level measurements from existing and new borings/wells in both deltaic and bedrock aquifers should be presented and discussed. It would be relevant to have one complete annual cycle of water-level data to evaluate possible seasonal fluctuations in the water table. Provide a plan to regularly monitor water levels in the borings/wells throughout the duration of mining operations. The frequency of water-level data collection should be sufficient to adequately describe the normal seasonal fluctuations of the water table elevation in both the deltaic and bedrock aquifers.

The important seeps and springs in the Watkins Glen State Park should be identified and their recharge areas and groundwater source areas described.

B. Potential Impacts. Potential impacts that mining may have on groundwater will be identified and discussed, including the potential for impacts to the quality and quantity of groundwater, changes to existing groundwater flow patterns, and lowering of surrounding groundwater elevations. A discussion of local and regional groundwater should be provided including the potential for aquifer communication with the seeps and springs in Watkins Glen State Park in order to enable a more complete assessment of the proposed expansion on the hydrology of the gorge. The additional data collected, along with information obtained from borings, published geologic literature, site specific information, and on-site testing, will provide the basis for the hydrogeologic assessment.

Hydrogeologic information from east and south of the IGN property should be compared to

hydrogeologic information from the mining area to determine the direction of groundwater flow in the deltaic deposits. In addition to the contour maps showing both the elevations of water tables in the deltaic deposits and bedrock, geologic section profiles should be provided which shows water levels in both units both within the mining site and south and east of the mining site.

Microclimate experienced by Park visitors—

Comments received from NYS Office of Parks, Recreation, and Historic Preservation (OPRHP) included another concern that is related to potential changes to the hydrological conditions in Watkins Glen State Park. The hydrological conditions not only create microclimates and habitats for plants and animals but there is also a microclimate that is critical to the experience of Park visitors experience as they pass through the gorge.

The DEIS will describe the climatic conditions experienced in the gorge in scientific terms and in terms of seasonal changes. In addition, the dEIS will investigate how groundwater seeps and hydrological process are responsible for producing this microclimate. The dEIS will evaluate if any potential hydrological changes related to the mine expansion will result in potential adverse impact on the climatic conditions in the gorge currently being experienced by Park visitors. The dEIS will address what happens during drought conditions, which would be considered the worst case scenario.

C. Proposed Mitigation Measures. A discussion will be provided for the design, construction and operational procedures of the mine that will be utilized to minimize potential impacts to groundwater resources located on the mine site and within adjacent areas of the Watkins Gen State Park. This will include the separation distances which will be maintained between mining activities and the highest seasonal water table in unconsolidated materials.

Surface water

A. Existing Environmental Setting. Existing surface water resources within and in proximity to the proposed mine to include adjacent areas of Watkins Glen State Park and Glen Creek gorge will be identified and described. Streams, wetlands, floodplains (if any) and other surface water features will be identified and examined based on DEC classification and field observations. Existing drainage patterns within the mining area and in areas south and east of the IGN property will be described and mapped.

B. Potential Impacts. Impacts related to the alteration of the surface water drainage patterns associated with mining activities will be described and evaluated. An analysis of the surface water contribution from the lands affected by mining to the Watkins Gen State Park and the Glen Creek drainage will be evaluated and impacts discussed. The potential for impacts to the quality and quantity of surface water will be evaluated.

C. Proposed Mitigation Measures. A discussion will be provided for the design, construction and operational procedures of the mine that will be utilized to minimize potential impacts to surface water resources located within the Watkins Glen State Park.

Potential Impacts Northeast and East of the Mine Site in Down Slope Residential Areas

Comments received on the draft Scope of the dEIS, from residents living in the down hill areas,

reported an increased frequency of flooding incidents and other observations related to changes in groundwater seeps and springs on their property or their neighbors property.

Provide an analysis of the potential down slope impact of surface water flow resulting from an increased groundwater discharge related to mine expansion, and the potential formation of new off-site, down slope springs and seeps.

Discuss any design, construction and operational procedures of the mine that may be utilized to minimize these impacts.-

► **Visual Resources**

Comments received on the draft Scope included concerns with the mining site being visible at greater distances than had been included in the previous visual impact analysis. The previous impact analysis had concluded that there were no significant visual impacts to nearby receptors (NYS Route 409, nearby residents, the two cemeteries and the Watkins Glen State Park).

Two NYS roadways, Route 414 and Route 79 were mentioned in the comments. The current mining operation is within the viewshed of certain locations along these roads. Comments received from Ms. Kate Bartholomew of the Schuyler County Environmental Management Council included photos from four locations, three from locations on NYS Route 414 (view from the southeast end of Seneca Lake, the view from the curb at Clute Park, and the view from the northeast corner of 4th and Porter Streets in Watkins Glen) and one from a location on NYS Route 79 (view just south of the Village of Burdett, just before descending the hill to the southeastern village limits of Watkins Glen).

An 18 mile section of NYS Route 414 is being proposed to be designated as the Seneca Lake and Lodi Scenic Byway. Using the Department's guidance document, Assessing and Mitigating Visual Impacts (DEP-00-2), NYS highways designated as Scenic Byways would be considered to be significant scenic and aesthetic resources of statewide concern. The Seneca Lake and Lodi Scenic Byway is NYS RT 414 extends from the beginning of NYS Route 414 at the intersection of NYS Route 14 in the Village of Watkins Glen, at which point NYS RT 414 is called 4th Street and continues around the southeastern and eastern sides of Seneca Lake until it reaches the Hamlet of Lodi.

The dEIS will include a visual impact assessment of the mine location in the viewsheds from the four locations where photos have been submitted. Procedures found in the Department's DEP-00-2 Guidance Document (<http://www.dec.ny.gov/regulations/2374.html>) should be followed in undertaking the visual impact assessment.

A discussion will be provided for the design, construction and operational procedures that will be utilized to minimize potential impacts to the two roadways.

► **Cultural Resources - Historic & Archaeological Resources**

Historic Resources - Watkins Glen State Park

Existing Environmental Setting: The Watkins Glen State Park is eligible for listing in both the National and State Registries of Historic Places. The dEIS should review and describe the

historical attributes of the Watkins Glen State Park which qualifies it for being eligible for listing in the National and State registries.

Potential Environmental Impacts: The dEIS will examine the potential adverse impacts the mining operation may have on the historical attributes of the State Park, including the impacts on the Park's groundwater and surface water resources, which define this State Park's uniqueness.

Proposed Mitigation Measures:

A discussion will be provided for the design, construction and operational procedures of the mine that will be utilized to minimize potential impacts to the State Park's historical significance.

5.0 ALTERNATIVES TO THE PROPOSED ACTION

- ▶ **No Action Alternative For Mine Site.** Alternatives to the proposed new mine will be evaluated including the no action alternative. This alternative will be evaluated based on the assumption that the mine is not expanded.
- ▶ **Alternative Size.** Alternatives that reflect the evaluation of changes in the scale or magnitude of the project will include a comparison of impacts covered by the dEIS Scope, which includes: geological, ecological, water, visual and cultural resources. This section will include evaluation of reduction of Life of Mine Boundary by increasing setback distances from the Watkins Glen State Park boundary, in particular those areas of the proposed Life of Mine that drain directly toward the State Park.
- ▶ **Alternative Design and Technology.** The design of the project and operational practices will be evaluated against perceived impacts.
- ▶ **Alternative Land Use.** Explore and evaluate alternative mined land reclamation approaches which would result in land use compatible with functions and benefits of the Watkins Glen State Park.
- ▶ **Alternative Development Schedule.** Alternative development schedules associated with acceleration or slow-down of the proposed extraction rate will be analyzed for their potential to reduce environmental impacts.

6.0 List of Application Documents This list will also include any underlying studies, reports and other information considered in preparing the statement including the final written scope.

7.0 Tables

8.0 References

9.0 Appendices

Table 1.0

State Agencies		
Agency	Permit/Interest	Applicable Law/Regulation
NYS DEC	Mining permit Stormwater SPDES permit Air emission permits - processing, and. manufacturing	ECL 23-2701 ECL 17-0801 ECL 19-0101 ECL 17-1009
NYS DOT	Curb cut: highway permit(s) (if required)	Highway Law §52 Vehicle and Traffic Law §1220-a
NYS Office of Parks, Recreation and Historic Preservation	Cultural resources, historic preservation review	Parks, Recreation and Historic Preservation Law Article 14
Federal Agencies		
US Army Corps of Engineers	Federal Wetland Permit (if required)	
Mining Safety Health Administration	Information Regulates mine safety	30 USC 811, 957, 961
Local Government		
Town of Dix	Site Plan Review	
Schuyler County	Highway permit (if needed)	

New York State Department of Environmental Conservation

Division of Environmental Permits, Region 8

6274 East Avon-Lima Road, Avon, New York 14414-9519

Phone: (585) 226-5400 • FAX: (585) 226-2830

Website: www.dec.ny.gov



Alexander B. Grannis
Commissioner

FAX COVER SHEET

Date: August 18, 2008

To: Marty Wojcik
FAX = 607-535-5523

From: Peter Lent

Number of Pages, including cover: ____ 12 ____

Notes:

Attached is the dEIS Scope Outline for Expansion of the Padua Mine

Let me know if you have any questions.

Phone: 585-226-5390.

FAX: 585-226-2830

E-mail: palent@gw.dec.state.ny.us

Original being mailed

Original not being mailed

FAXED
4:20 PM
8-18-2008



APPENDIX I

VISUAL ASSESSMENT PHOTOGRAPHIC LOG

PHOTOGRAPHIC LOG
IT'S GREENER NOW, LLC
PADUA RIDGE GRAVEL MINE
TOWN OF DIX, SCHUYLER COUNTY, NEW YORK



View from State Route 414 looking southwest towards the site



View from parking area at Clute Park looking southwest towards the site.

PHOTOGRAPHIC LOG
IT'S GREENER NOW, LLC
PADUA RIDGE GRAVEL MINE
TOWN OF DIX, SCHUYLER COUNTY, NEW YORK



View from Clute Park looking southwest towards the site.



View from State Route 414 looking southwest towards the site.

PHOTOGRAPHIC LOG
IT'S GREENER NOW, LLC
PADUA RIDGE GRAVEL MINE
TOWN OF DIX, SCHUYLER COUNTY, NEW YORK



View from State Route 8 looking west towards the site.



View from along State Route 414 looking southwest towards the site.

PHOTOGRAPHIC LOG
IT'S GREENER NOW, LLC
PADUA RIDGE GRAVEL MINE
TOWN OF DIX, SCHUYLER COUNTY, NEW YORK



View from a parking area at Clute Park looking southwest towards the site.



View from State Route 79 looking southeast towards the site.

PHOTOGRAPHIC LOG
IT'S GREENER NOW, LLC
PADUA RIDGE GRAVEL MINE
TOWN OF DIX, SCHUYLER COUNTY, NEW YORK



View from intersection of State Route 8 and Cass Road looking west towards the site.



View from State Route 8 looking west towards the site.

PHOTOGRAPHIC LOG
IT'S GREENER NOW, LLC
PADUA RIDGE GRAVEL MINE
TOWN OF DIX, SCHUYLER COUNTY, NEW YORK



View from State Route 414 looking southwest towards the site.



View from State Route 409 looking southeast towards the site.

PHOTOGRAPHIC LOG
IT'S GREENER NOW, LLC
PADUA RIDGE GRAVEL MINE
TOWN OF DIX, SCHUYLER COUNTY, NEW YORK



Another view from State Route 409 looking southeast towards the site.



View from State Route 409 at the gated access to Elk Park at The Glen looking east towards the site.

PHOTOGRAPHIC LOG
IT'S GREENER NOW, LLC
PADUA RIDGE GRAVEL MINE
TOWN OF DIX, SCHUYLER COUNTY, NEW YORK



View from State Route 409 looking south towards the site entrance signage.



View from State Route 409 and the Watkins Glen State Park Upper Entrance signage looking east towards the site.

PHOTOGRAPHIC LOG
IT'S GREENER NOW, LLC
PADUA RIDGE GRAVEL MINE
TOWN OF DIX, SCHUYLER COUNTY, NEW YORK



View from State Route 8 looking southwest towards the site.



View from Cass Road looking west towards the site.



DRAFT ENVIRONMENTAL IMPACT STATEMENT
It's Greener Now, Inc. – Padua Ridge Gravel Mine Town of Dix, New York

APPENDIX J

WGSP HYDROGEOLOGIC AND ECOLOGIC DOCUMENTATION



**WATKINS GLEN STATE PARK HYDROGEOLOGIC AND
ECOLOGIC DOCUMENTATION
IT'S GREENER NOW, LLC - PADUA RIDGE GRAVEL MINE
TOWN OF DIX, SCHUYLER COUNTY, NEW YORK
MAY, 2019**

This document summarizes the findings of a hydrologic and geologic review of a portion of Watkins Glen State Park. This review was conducted in support of a Draft Environmental Impact Statement prepared for an application to modify the Mined Land Reclamation Permit for the It's Greener Now, LLC Padua Ride Gravel Mine in the Town of Dix, Schuyler County, New York. The review consisted of a June 12, 2017 reconnaissance of Watkins Glen State Park via gorge trails to assess ecological setting, including the potential presence of the threatened species Leedy's Roseroot, *Rhodiola integrifolia* spp. *Leedyi.*, occurrences of microclimate-associated ecological communities, and locations of bedrock- and till-associated groundwater seeps and springs. Watkins Glen State Park contains a deeply incised gorge cut by Glen Gorge, with steep bedrock walls and numerous waterfalls.

Although a thorough review of ecological conditions within accessible portions of the gorge was performed, access limitations, practicality, and safety issues prevented a full detailed accounting of groundwater seeps and of vegetation. Nonetheless, no occurrences of Leedy's Roseroot were documented. The New York Natural Heritage Program indicates only a single known specimen at this location (<https://guides.nynhp.org/leedys-roseroot/>), which according to the United States Fish and Wildlife Service (Leedy's Roseroot Recovery Plan, September 25, 1998), is reportedly a transplant.

Microclimate-associated communities occur throughout the gorge, associated with shaded areas and available water seeps. However, the predominate sustained source of water for the upper walls of the gorge for the majority of the study area appears to be surface inflow at or near the rim of the gorge, which is derived from shallow, till-associated seeps and springs (see the DEIS for a discussion of regional and site hydrogeology). Vegetation in general within the gorge is largely associated with these till-associated spring/seep discharges which enter over the rim of the gorge. Bedrock-derived groundwater also enters the gorge walls and in select locations supports additional vegetation. Bedrock seeps and springs (and associated vegetation) generally occur at significantly lower elevations within the gorge, often at or near the creek's water surface. Except



for till-associated spring/seep flow, the upper bedrock walls of the gorge are essentially dry for much of the study area.

The following photographic log documents ecologic and hydrologic conditions encountered within the gorge and along the gorge rim.



PHOTOGRAPHIC LOG

WATKINS GLEN STATE PARK PHOTOGRAPHIC LOG
IT'S GREENER NOW, LLC - PADUA RIDGE GRAVEL MINE
TOWN OF DIX, SCHUYLER COUNTY, NEW YORK

Photos G1, 180, 181, 182: Shallow/till-associated spring/seep along Indian Trail above gorge rim, with overland flow toward gorge.

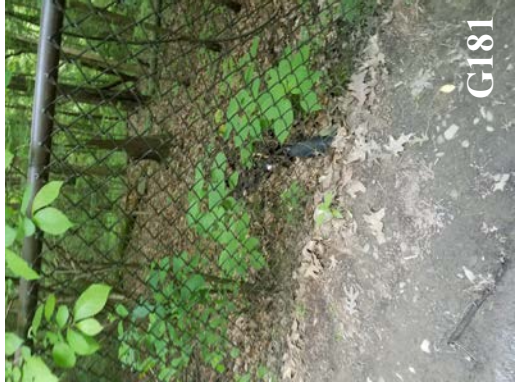

WATKINS GLEN STATE PARK PHOTOGRAPHIC LOG
IT'S GREENER NOW, LLC - PADUA RIDGE GRAVEL MINE
TOWN OF DIX, SCHUYLER COUNTY, NEW YORK

Photos G6, 7: Bedrock outcrop at western end of Gorge Trail with possible bedrock groundwater seepage, common vegetation.



WATKINS GLEN STATE PARK PHOTOGRAPHIC LOG
IT'S GREENER NOW, LLC - PADUA RIDGE GRAVEL MINE
TOWN OF DIX, SCHUYLER COUNTY, NEW YORK

Photos G8, 9: Bedrock fracture along Gorge Trail with apparent groundwater seepage.



WATKINS GLEN STATE PARK PHOTOGRAPHIC LOG

IT'S GREENER NOW, LLC - PADUA RIDGE GRAVEL MINE

TOWN OF DIX, SCHUYLER COUNTY, NEW YORK

Photos G11, 13, 185: Gorge microclimate vegetation along Gorge Trail.



WATKINS GLEN STATE PARK PHOTOGRAPHIC LOG
IT'S GREENER NOW, LLC - PADUA RIDGE GRAVEL MINE
TOWN OF DIX, SCHUYLER COUNTY, NEW YORK

Photos G16, 17: Gorge vegetation supported by shallow/overland flow (till-associated discharge) from above.

Photo G20: Bedrock spring along Gorge Trail.



WATKINS GLEN STATE PARK PHOTOGRAPHIC LOG
IT'S GREENER NOW, LLC - PADUA RIDGE GRAVEL MINE
TOWN OF DIX, SCHUYLER COUNTY, NEW YORK

Photos G22, 23: Cascading water from surface flow, likely from till-associated seep(s)/spring(s) referenced in Photos G1, 180-182.

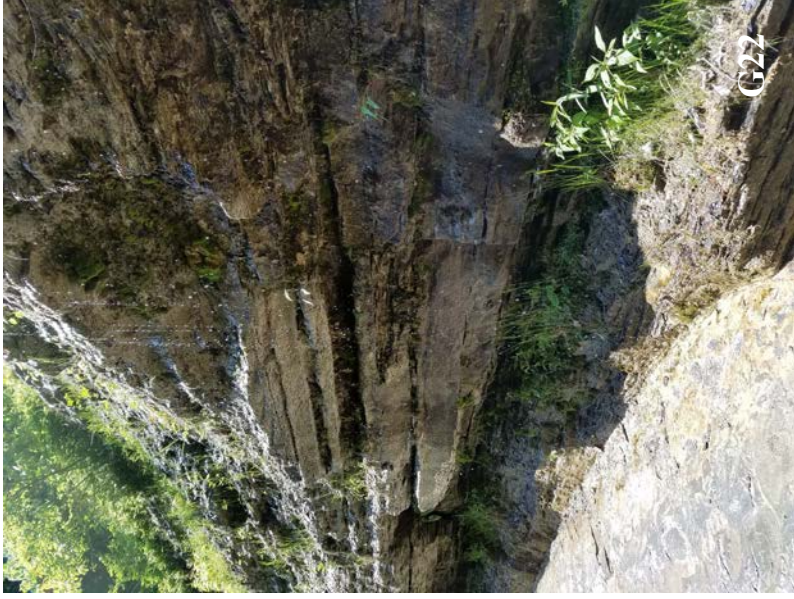

WATKINS GLEN STATE PARK PHOTOGRAPHIC LOG
IT'S GREENER NOW, LLC - PADUA RIDGE GRAVEL MINE
TOWN OF DIX, SCHUYLER COUNTY, NEW YORK

Photos G25, 28, 33: Common vegetation and associated bedrock- and shallow-surface derived seeps and flow along the Gorge Trail.



WATKINS GLEN STATE PARK PHOTOGRAPHIC LOG
IT'S GREENER NOW, LLC - PADUA RIDGE GRAVEL MINE
TOWN OF DIX, SCHUYLER COUNTY, NEW YORK

Photos G34, 35: Common vegetation and associated bedrock- and shallow-surface derived seeps and flow along the Gorge Trail.



WATKINS GLEN STATE PARK PHOTOGRAPHIC LOG
IT'S GREENER NOW, LLC - PADUA RIDGE GRAVEL MINE
TOWN OF DIX, SCHUYLER COUNTY, NEW YORK

Photos G38, 39: Common vegetation and associated bedrock- and shallow-surface derived seeps and flow along the Gorge Trail.



G38



G39

WATKINS GLEN STATE PARK PHOTOGRAPHIC LOG
IT'S GREENER NOW, LLC - PADUA RIDGE GRAVEL MINE
TOWN OF DIX, SCHUYLER COUNTY, NEW YORK

Photos G43, 47, 48: Narrow chute showing dry bedrock to near water surface, indicating minimal bedrock-derived groundwater associated with vegetation above.



WATKINS GLEN STATE PARK PHOTOGRAPHIC LOG
IT'S GREENER NOW, LLC - PADUA RIDGE GRAVEL MINE
TOWN OF DIX, SCHUYLER COUNTY, NEW YORK

Photo G53: Microclimate vegetation supported by rim-associated flows (till-derived groundwater).

Photo G55: Bedrock seeps deep within gorge, with dry rock above.



WATKINS GLEN STATE PARK PHOTOGRAPHIC LOG
IT'S GREENER NOW, LLC - PADUA RIDGE GRAVEL MINE
TOWN OF DIX, SCHUYLER COUNTY, NEW YORK

Photos G59, 60, 61: Dry bedrock along Gorge Trail with rim/surface (till-associated) inflow above.



WATKINS GLEN STATE PARK PHOTOGRAPHIC LOG
IT'S GREENER NOW, LLC - PADUA RIDGE GRAVEL MINE
TOWN OF DIX, SCHUYLER COUNTY, NEW YORK

Photos G62, 63: Rim/surface (till-based) inflow and associated vegetation along Gorge Trail; dry bedrock in gorge walls above and below trail.



WATKINS GLEN STATE PARK PHOTOGRAPHIC LOG
IT'S GREENER NOW, LLC - PADUA RIDGE GRAVEL MINE
TOWN OF DIX, SCHUYLER COUNTY, NEW YORK

Photos G64, 65, 66: Rim/surface (till-based) inflow and associated vegetation along Gorge Trail; dry bedrock in gorge walls above and below trail.

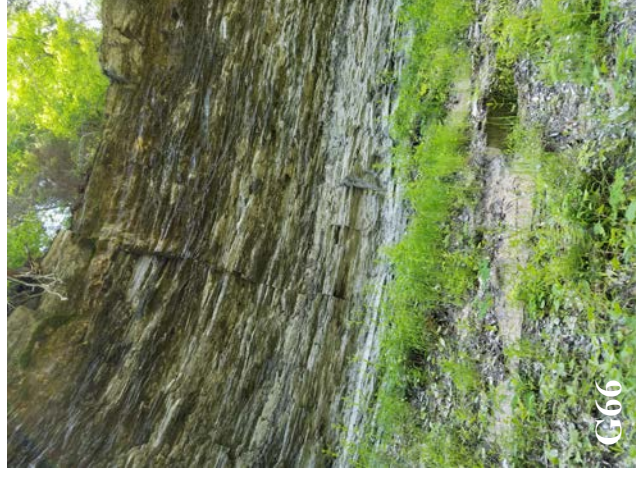

WATKINS GLEN STATE PARK PHOTOGRAPHIC LOG
IT'S GREENER NOW, LLC - PADUA RIDGE GRAVEL MINE
TOWN OF DIX, SCHUYLER COUNTY, NEW YORK

Photos G68, 71: Cascade (surface inflow) at Rainbow Falls along Gorge Trail.



G68



G71

WATKINS GLEN STATE PARK PHOTOGRAPHIC LOG
IT'S GREENER NOW, LLC - PADUA RIDGE GRAVEL MINE
TOWN OF DIX, SCHUYLER COUNTY, NEW YORK

Photo G77: North gorge wall downstream of Rainbow Falls along the Gorge Trail; mix of surface/shallow (till) inflow and bedrock seepage.

Photos G80, 82: Vertical sections of dry bedrock with moistened bedrock indicating surface/shallow (till) water inflow, possibly associated with spring referenced in Photos G156-158.



WATKINS GLEN STATE PARK PHOTOGRAPHIC LOG
IT'S GREENER NOW, LLC - PADUA RIDGE GRAVEL MINE
TOWN OF DIX, SCHUYLER COUNTY, NEW YORK

Photo G91: Dry bedrock gorge north wall with center band of wall moistened from surface/shallow (till) rim inflow from above.
Photo G94: Dry bedrock gorge north wall along Gorge Trail.

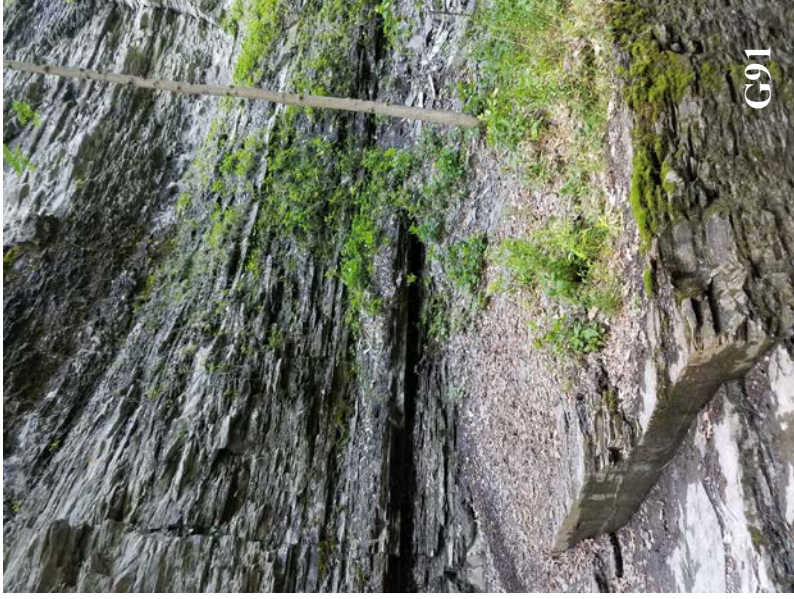

WATKINS GLEN STATE PARK PHOTOGRAPHIC LOG
IT'S GREENER NOW, LLC - PADUA RIDGE GRAVEL MINE
TOWN OF DIX, SCHUYLER COUNTY, NEW YORK

Photos G96, 97, 98, 100: Dry bedrock gorge wall (north) with occasional vertical section moistened by surface/shallow (till) rim inflow from above.

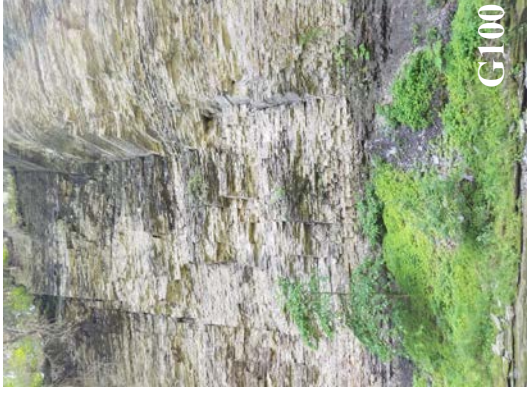

WATKINS GLEN STATE PARK PHOTOGRAPHIC LOG
IT'S GREENER NOW, LLC - PADUA RIDGE GRAVEL MINE
TOWN OF DIX, SCHUYLER COUNTY, NEW YORK

Photos G106, 108, 109, 110: Vegetation fed by surface/shallow (till) rim inflow along north side of Gorge Trail.



WATKINS GLEN STATE PARK PHOTOGRAPHIC LOG
IT'S GREENER NOW, LLC - PADUA RIDGE GRAVEL MINE
TOWN OF DIX, SCHUYLER COUNTY, NEW YORK

Photos G125, 126, 127, 129: Dry bedrock gorge walls along Gorge Trail near Minnehaha Falls/Curtain Cascade, indicating minimal to no bedrock groundwater available for majority of gorge depth.

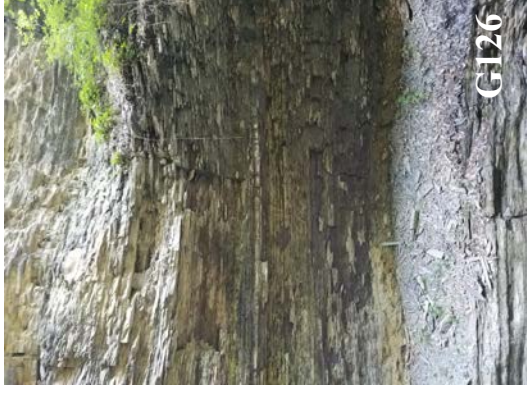

WATKINS GLEN STATE PARK PHOTOGRAPHIC LOG
IT'S GREENER NOW, LLC - PADUA RIDGE GRAVEL MINE
TOWN OF DIX, SCHUYLER COUNTY, NEW YORK

Photos G130, 133: Dry bedrock gorge walls to near water surface.

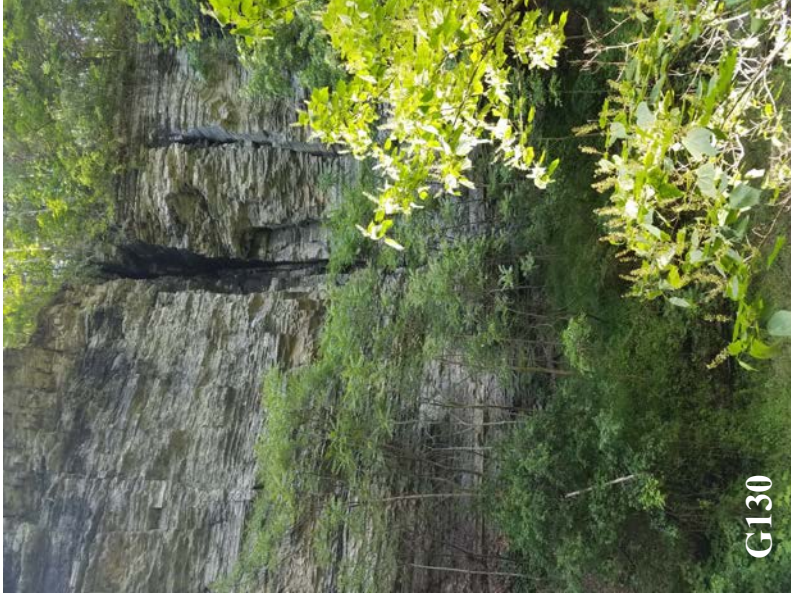

G130



G133

WATKINS GLEN STATE PARK PHOTOGRAPHIC LOG
IT'S GREENER NOW, LLC - PADUA RIDGE GRAVEL MINE
TOWN OF DIX, SCHUYLER COUNTY, NEW YORK

Photo G139: Dry north wall of gorge at lower (east) end of park; occasional vertical bands of moistened rock demonstrate mechanism of rim inflow from surface/shallow (till) seeps/springs.

Photo G152: Dry south gorge wall from north gorge rim along Indian Trail.

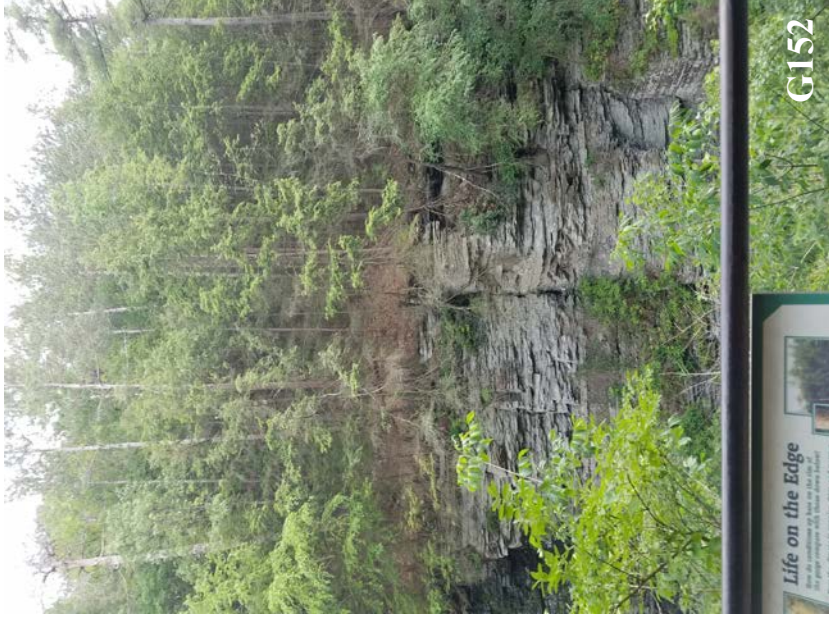

WATKINS GLEN STATE PARK PHOTOGRAPHIC LOG
IT'S GREENER NOW, LLC - PADUA RIDGE GRAVEL MINE
TOWN OF DIX, SCHUYLER COUNTY, NEW YORK

Photos G156, 157, 158: Till spring with surface flow & culvert conveying overland to north rim of gorge along Indian Trail; possible source of rim inflow noted in Photos G80, 82.

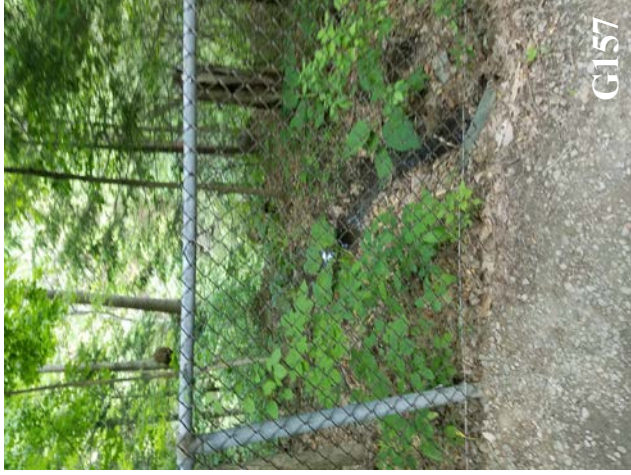

WATKINS GLEN STATE PARK PHOTOGRAPHIC LOG
IT'S GREENER NOW, LLC - PADUA RIDGE GRAVEL MINE
TOWN OF DIX, SCHUYLER COUNTY, NEW YORK

Photo G161: Cascade at Rainbow Falls from north rim of gorge along Indian Trail.

Photos G162, 163: Till-based groundwater spring along Indian Trail.



WATKINS GLEN STATE PARK PHOTOGRAPHIC LOG
IT'S GREENER NOW, LLC - PADUA RIDGE GRAVEL MINE
TOWN OF DIX, SCHUYLER COUNTY, NEW YORK

Photos G164, 165, 166: Surface flow and culverts along Indian Trail conveying water from spring (Photos G162, 163) to gorge rim.



G164



G165



G166

WATKINS GLEN STATE PARK PHOTOGRAPHIC LOG
IT'S GREENER NOW, LLC - PADUA RIDGE GRAVEL MINE
TOWN OF DIX, SCHUYLER COUNTY, NEW YORK

Photos G167, 168, 169: Surface flow and culverts along Indian Trail conveying water from spring (Photos G162, 163) to gorge rim.

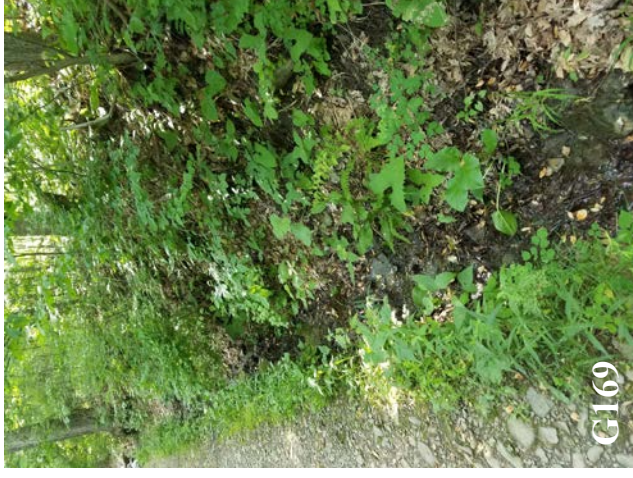

WATKINS GLEN STATE PARK PHOTOGRAPHIC LOG
IT'S GREENER NOW, LLC - PADUA RIDGE GRAVEL MINE
TOWN OF DIX, SCHUYLER COUNTY, NEW YORK

Photos G170, 171: Surface flow and culverts along Indian Trail conveying water from spring (Photos G162, 163) to gorge rim.



G170



G171

WATKINS GLEN STATE PARK PHOTOGRAPHIC LOG
IT'S GREENER NOW, LLC - PADUA RIDGE GRAVEL MINE
TOWN OF DIX, SCHUYLER COUNTY, NEW YORK

Photos G176, 178: Surface flow and culverts along Mile Point Road trail conveying water from spring (Photos G162, 163) to gorge rim.

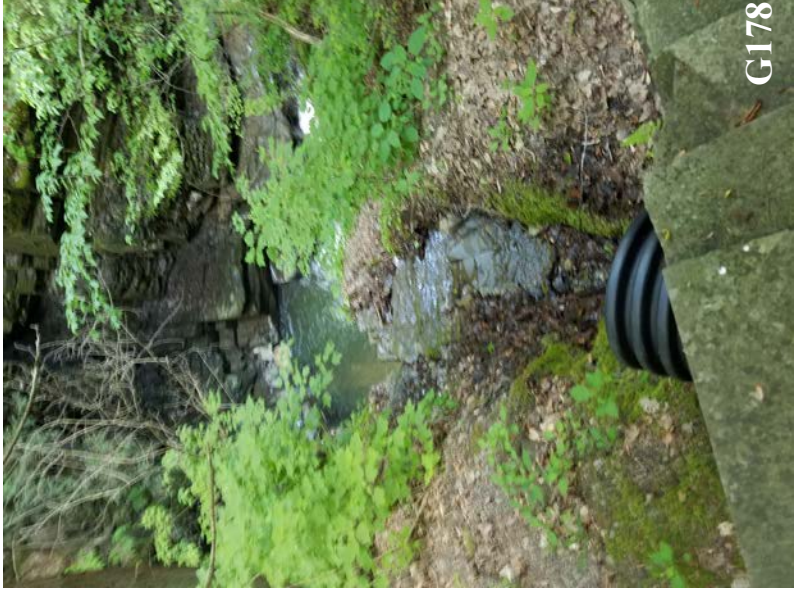



DRAFT ENVIRONMENTAL IMPACT STATEMENT
It's Greener Now, Inc. – Padua Ridge Gravel Mine Town of Dix, New York

APPENDIX K

NYS OFFICE OF PARKS CORRESPONDENCE



April 23, 2019

SUBMITTED VIA E-MAIL

Ms. Sloane Bullough
Historic Sites Restoration Coordinator
New York State Historic Preservation Office (NY SHPO)
P.O. Box 189
Waterford, New York 12188-0189

**Re: It's Greener Now, LLC – Padua Gravel Pit
Padua Gravel Pit Expansion
Response to NY SHPO Request for Additional Information
JMT Job No. 16-S0157N-001**

Dear Ms. Bullough:

JMT of New York, Inc., on behalf of It's Greener Now, LLC (IGN), submits the following in response to the NY SHPO Request for Additional Information, as outlined in your letter, November 20, 2017 for the above referenced site. For ease of review, NY SHPO comments are repeated below in italics, followed by IGN's responses.

Before we can provide our comments, we will need more information to access the visual impact on the historic Grand Prix Road Course and the State Park. Please provide existing and proposed site plans for us to compare. Please also provide any other documentation that will help us understand how the setting at the .5 miles of the road course we are most concerned with will change. For example, we will need to know how the topography in this location will affect the setting and view. We recommend that the rural setting that is visible from the road course is preserved. Photos should be keyed to an existing conditions site plan and attached as a single PDF document to CRIS under "Attachments."

Please add the contact information for the Department of Environmental Conservation to the CRIS entry so that that person can be copied on all correspondence.

A Mine Plan Map (Sheet 1), Reclamation Plan (Sheet 2), and Final Grade Profiles (Sheet 3) are included with this letter as Attachment A. Please refer to Attachment A for further details.

Additionally, to assess potential visual impacts of the proposed project, JMT conducted a topographic- and vegetative cover-based sight line assessment from representative, residential and/or publicly accessible vantage points located within the general area. The visual assessment includes a narrative, Line-of-Sight Profiles Location Map (Sheet 8), Line-of-Sight Profiles (Sheet 9), and a Photographic Log - all of which are included with this letter as Attachment B. The visual assessment discusses the Watkins Glen Grand Prix Road Course and concludes there would be no resulting visual impacts. Views of the site from the Road Course are nearly entirely

screened by topography (including existing screening berms) and vegetation, and any potential view from the Road Course of continued operation of the mine site would be consistent with current conditions. Please refer to Attachment B for additional details.

For ease of review, and per request, this letter and its attachments have been uploaded to the CRIS site. Contact information for Scott Sheeley, the NYSDEC Region 8 - Regional Permit Administrator has also been uploaded to the CRIS site and is as follows:

Scott E. Sheeley
Regional Permit Administrator
NYS DEC Region 8 Headquarters
6274 E. Avon - Lima Road
Avon, New York 14414
Office no. 585-226-2466
Direct no. 585-226-5382

We trust that the information contained herein adequately addresses the items included in your letter, dated November 20, 2017. If you should have any questions or require further information, please do not hesitate to contact me at (845) 204-9239 or acarroll@jmt.com.

Sincerely,

JMT of New York, Inc.

Alexandra Carroll, GISP
Environmental Scientist

Attachments

cc w/ att.: M. Wocjik, IGN
K. Roe, Barclay Damon
E. Davidson, JMT



Parks, Recreation, and Historic Preservation

ANDREW M. CUOMO
Governor

ERIK KULLESEID
Acting Commissioner

May 23, 2019

Mrs. Alexandra Carroll
Environmental Scientist
JMT
19 British American Boulevard
Latham, NY 12110 *via e-mail only*

Re: DEC
Padua Ridge Sand & Gravel Mine (94.63 acres)
Dix, Schuyler Co.
06PR01547

Dear Mrs. Carroll,

Thank you for providing additional information regarding the project's impact on the Watkins Glen Grand Prix Road Course to the Division for Historic Preservation of the Office of Parks, Recreation and Historic Preservation (OPRHP). We have reviewed the submitted materials in accordance with the New York State Historic Preservation Act of 1980 (section 14.09 of the New York Parks, Recreation and Historic Preservation Law).

The project consists of the expansion of the existing sand and gravel mining operations. The additional materials you provided have resolved our concerns regarding the project's impact on the Road Course. However, the potential environmental impacts to New York State Parkland will need to be reviewed now. The project is adjacent to the Watkins Glen State Park, which is eligible for listing in the National Register. We have reached out to OPRHP Environmental Management Bureau and will communicate with you about the next steps.

Thank you for your patience in the review process. If you have questions, please contact me at 518-268-2158.

Sincerely,

Sloane Bullough
Historic Sites Restoration Coordinator

Division for Historic Preservation

P.O. Box 189, Waterford, New York 12188-0189 • (518) 237-8643 • parks.ny.gov



September 1, 2021

SUBMITTED VIA E-MAIL

Mr. John A. Bonafide
Director, Technical Preservation Services Bureau
New York State Historic Preservation Office (NY SHPO)
P.O. Box 189
Waterford, New York 12188-0189

**Re: It's Greener Now, LLC – Padua Gravel Pit
Padua Gravel Pit Expansion / Project ID: 06PR01547
Response to NY SHPO Request for Additional Information
JMT Job No. 16-S0157N-001**

Dear Mr. Bonafide:

JMT of New York, Inc., on behalf of It's Greener Now, LLC (IGN), submits the following in response to the NY SHPO/OPRHP Request for Additional Information, as outlined in your letter, July 2, 2019 for the above referenced site. For ease of review, NY SHPO/OPRHP comments are repeated below in *italics*, followed by IGN's responses.

Comment: *In reviewing this project, we noted that the newly proposed mine expansion will bring the commercial operations up to the boundary of Watkins Glen State Park. The park was designated eligible for inclusion in the New York State and National Registers of Historic Places in 2016. The park has been used by recreation seekers since the mid-19th century and remains today one of the state's most scenic destinations.*

Section 14.09 (NYSRHP) states: "Generally, adverse impacts occur under conditions which include but are not limited to (a) destruction or alteration of all or part of a property; (b) isolation or alteration of its surrounding environment; (c) introduction of visual, audible, or atmospheric elements that are out of character with the property or alter its setting; or (d) neglect of property resulting in its deterioration or destruction."

Our office is particularly concerned with section (c) above and the specific impacts to the park that might arise from the mine expansion. We found no assessment of anticipated increases in noise, dust, vibration, truck traffic or other direct and indirect impacts that the expansion of this extractive industrial would have on the historic park.

It is our belief that an expansion of the mining operation up to the boundary of the state land has significant potential to adversely impact the historic character of the park. As such, we are requesting that an assessment of these factors be provided to this office as part of a more comprehensive alternatives analysis. This study should assess efforts that would avoid or minimize such impacts.

Response: As identified by your office, the existing mine area currently abuts the Watkins Glen State Park property and will continue to do so as the mine expands. However, as operations expand, mining excavation operations will be moving further away from the Watkins Glen gorge. While the overall acreage of the mine will increase over the life of the project, the total disturbed area (active mining excavation area, previously mined un-reclaimed areas, and processing areas) will be minimized by employing concurrent reclamation practices and by limiting stripping activities in advance of mining. As operations progress, there will not be a significant increase in the mine's

production rate. Furthermore, the proposed mining modification will not result in a significant change from previously permitted historic operations.

Please note, a draft Environmental Impact Statement (dEIS) was developed by JMT in May 2019 to satisfy the requirements of the State Environmental Quality Review Act (SEQR) for the proposed mine expansion. The dEIS was prepared in accordance with 6 NYCRR NYCRR 617.9(b) to address those potential impacts identified in the draft Environmental Impact Statement (dEIS) Final Scoping Outline, dated August 18, 2008. NYSDEC has been designated as the lead agency. The dEIS prepared in 2019 evaluated the likelihood and significance of the potential environmental impacts and outlines mitigation measures, where appropriate, to resources including: geological resources, ecological resources, water resources, visual resources, and cultural (historic and archaeological) resources.

NYSDEC reviewed the submitted dEIS, and has issued two response letters, dated May 22, 2019 and July 19, 2019, respectively requesting information. To address the comments contained within the letters, JMT revised the dEIS documents, including the noise projection analysis and visual impact assessment. Dust, vibration, and truck traffic impacts are outside of the scope of the dEIS, per the 2008 Final Scoping Outline referenced above. However, the Mined Land Use Plan (MLUP), which is included as Appendix F in the dEIS, includes a section for potential impacts from dust as well as traffic. The MLUP is included as part of the dEIS as it provides a summary of the mining and reclamation plans for the mine site.

Consistent with current excavation activity at the Padua Ridge Gravel Mine, standard industry equipment will be used to strip, excavate, and haul materials from bank faces. Bulldozers, scrapers, front-end wheel loaders, haul trucks and other standard industry equipment will be used as needed to accomplish each task. There is no proposed blasting.

For your reference, the 2019 dEIS has been uploaded to the CRIS site and IGN's response to the May 22, 2019 and July 19, 2019 NYSDEC letters (which includes the updated dEIS documents) are in the process of being uploaded.

We trust that the information contained herein adequately addresses the items included in your letter, dated July 2, 2019. If you should have any questions or require further information, please do not hesitate to contact me at (518) 218-5925 or acarroll@jmt.com.

Sincerely,
JMT of New York, Inc.



Alexandra Carroll, GISP
Associate

Attachments

cc w/ att.: M. Wocjik, IGN
K. Roe, Barclay Damon
K. Carlson, NYSDEC
D. Carter, OPRHP
F. Bonn, OPRHP
E. Davidson, JMT



Parks, Recreation, and Historic Preservation

KATHY HOCHUL
Governor

ERIK KULLESEID
Commissioner

December 10, 2021

Mrs. Alexandra Carroll
Environmental Scientist
JMT
19 British American Boulevard
Latham, NY 12110
via e-mail only

Re: DEC
Padua Ridge Sand & Gravel Mine (94.63 acres)
Dix, Schuyler Co.
06PR01547

Dear Mrs. Carroll,

Thank you for providing additional information to the Division for Historic Preservation of the Office of Parks, Recreation and Historic Preservation (OPRHP). We have reviewed the submitted materials in accordance with the New York State Historic Preservation Act of 1980 (section 14.09 of the New York Parks, Recreation and Historic Preservation Law).

The project consists of the expansion of the existing sand and gravel mining operations. The additional materials you provided have resolved our concerns regarding the project's impact on the Watkins Glen State Park, which is eligible for listing in the National Register.

It is the opinion of OPRHP that the project will have No Adverse Impact on historic resources.

If you have questions, please contact me at sloane.bullough@parks.ny.gov.

Sincerely,

Sloane Bullough
Historic Sites Restoration Coordinator

Division for Historic Preservation

P.O. Box 189, Waterford, New York 12188-0189 • (518) 237-8643 • parks.ny.gov



APPENDIX L

ENVIRONMENTAL ASSESSMENT FORM (EAF)

Full Environmental Assessment Form
Part 1 - Project and Setting

Instructions for Completing Part 1

Part 1 is to be completed by the applicant or project sponsor. Responses become part of the application for approval or funding, are subject to public review, and may be subject to further verification.

Complete Part 1 based on information currently available. If additional research or investigation would be needed to fully respond to any item, please answer as thoroughly as possible based on current information; indicate whether missing information does not exist, or is not reasonably available to the sponsor; and, when possible, generally describe work or studies which would be necessary to update or fully develop that information.

Applicants/sponsors must complete all items in Sections A & B. In Sections C, D & E, most items contain an initial question that must be answered either “Yes” or “No”. If the answer to the initial question is “Yes”, complete the sub-questions that follow. If the answer to the initial question is “No”, proceed to the next question. Section F allows the project sponsor to identify and attach any additional information. Section G requires the name and signature of the project sponsor to verify that the information contained in Part 1 is accurate and complete.

A. Project and Sponsor Information.

Name of Action or Project: It's Greener Now, Inc. - Padua Ridge Gravel Mine Expansion		
Project Location (describe, and attach a general location map)*: 3362 Route 409, Watkins Glen, New York 14891		
Brief Description of Proposed Action (include purpose or need): The applicant seeks to expand their existing sand and gravel mining operations west and northward of their currently NYSDEC- permitted Life-of-Mine affected area for an additional 60.95 +/- acres. The current Life-of-Mine at the Padua Ridge Gravel Mine located in Watkins Glen, Schuyler County, New York is 14.33 +/- acres and the proposed total Life-of-Mine affected area is 75.28 +/- acres. Although no increase in production is anticipated at this time, the additional acreage would increase available reserves. Please see the attached draft Environmental Impact Statement (dEIS) and supporting documentation for a detailed description of the proposed action, methods, and analysis of potential environmental impacts.		
Name of Applicant/Sponsor: It's Greener Now, Inc. (Attn: Martin Wojcik)	Telephone: (607) 535-5525	E-Mail: paduaridge@yahoo.com
Address: 3362 Route 409		
City/PO: Watkins Glen	State: New York	Zip Code: 14891
Project Contact (if not same as sponsor; give name and title/role):	Telephone:	E-Mail:
Address:		
City/PO:	State:	Zip Code:
Property Owner (if not same as sponsor):	Telephone:	E-Mail:
Address:		
City/PO:	State:	Zip Code:

*Site Location Map is located in Figure 1 of the DEIS

B. Government Approvals

B. Government Approvals, Funding, or Sponsorship. (“Funding” includes grants, loans, tax relief, and any other forms of financial assistance.)		
Government Entity	If Yes: Identify Agency and Approval(s) Required	Application Date (Actual or projected)
a. City Council, Town Board, <input type="checkbox"/> Yes <input checked="" type="checkbox"/> No or Village Board of Trustees		
b. City, Town or Village Planning Board or Commission <input checked="" type="checkbox"/> Yes <input type="checkbox"/> No	Special Use Permit	September 2021
c. City Council, Town or Village Zoning Board of Appeals <input type="checkbox"/> Yes <input checked="" type="checkbox"/> No		
d. Other local agencies <input type="checkbox"/> Yes <input checked="" type="checkbox"/> No		
e. County agencies <input type="checkbox"/> Yes <input checked="" type="checkbox"/> No		
f. Regional agencies <input type="checkbox"/> Yes <input checked="" type="checkbox"/> No		
g. State agencies <input checked="" type="checkbox"/> Yes <input type="checkbox"/> No	NYSDEC for SPDES MGSP; Mining Permit; Air Permit/Registration; SHPO; NYSDOT (if required)	April 2018
h. Federal agencies <input type="checkbox"/> Yes <input checked="" type="checkbox"/> No		
i. Coastal Resources. <ul style="list-style-type: none"> i. Is the project site within a Coastal Area, or the waterfront area of a Designated Inland Waterway? <input type="checkbox"/> Yes <input checked="" type="checkbox"/> No ii. Is the project site located in a community with an approved Local Waterfront Revitalization Program? <input type="checkbox"/> Yes <input checked="" type="checkbox"/> No iii. Is the project site within a Coastal Erosion Hazard Area? <input type="checkbox"/> Yes <input checked="" type="checkbox"/> No 		

C. Planning and Zoning

C.1. Planning and zoning actions.	
Will administrative or legislative adoption, or amendment of a plan, local law, ordinance, rule or regulation be the only approval(s) which must be granted to enable the proposed action to proceed?	<input type="checkbox"/> Yes <input checked="" type="checkbox"/> No
<ul style="list-style-type: none"> • If Yes, complete sections C, F and G. • If No, proceed to question C.2 and complete all remaining sections and questions in Part 1 	
C.2. Adopted land use plans.	
a. Do any municipally- adopted (city, town, village or county) comprehensive land use plan(s) include the site where the proposed action would be located?	<input checked="" type="checkbox"/> Yes <input type="checkbox"/> No
If Yes, does the comprehensive plan include specific recommendations for the site where the proposed action would be located?	<input type="checkbox"/> Yes <input checked="" type="checkbox"/> No
b. Is the site of the proposed action within any local or regional special planning district (for example: Greenway Brownfield Opportunity Area (BOA); designated State or Federal heritage area; watershed management plan; or other?)	<input type="checkbox"/> Yes <input checked="" type="checkbox"/> No
If Yes, identify the plan(s):	

c. Is the proposed action located wholly or partially within an area listed in an adopted municipal open space plan, or an adopted municipal farmland protection plan?	<input checked="" type="checkbox"/> Yes <input type="checkbox"/> No
If Yes, identify the plan(s):	
The Town of Dix Comprehensive Plan- The Pioneer Plan 2001. (This plan references the entire Town of Dix. As such, the project location is included.)	

C.3. Zoning

- a. Is the site of the proposed action located in a municipality with an adopted zoning law or ordinance. Yes No
If Yes, what is the zoning classification(s) including any applicable overlay district?
R-1 (Residential Low Density)
- b. Is the use permitted or allowed by a special or conditional use permit? Yes No
- c. Is a zoning change requested as part of the proposed action? Yes No
If Yes,
i. What is the proposed new zoning for the site? _____

C.4. Existing community services.

- a. In what school district is the project site located? Watkins Glen Central School District
- b. What police or other public protection forces serve the project site?
Watkins Glen Police Department, New York State Police, Schuyler County Sheriff's Department
- c. Which fire protection and emergency medical services serve the project site?
Watkins Glen Fire Department
- d. What parks serve the project site?
Watkins Glen State Park

D. Project Details

D.1. Proposed and Potential Development

- a. What is the general nature of the proposed action (e.g., residential, industrial, commercial, recreational; if mixed, include all components)? Industrial (mineral extraction)
- b. a. Total acreage of the site of the proposed action? 75.28 +/- acres
b. Total acreage to be physically disturbed? 75.28 +/- acres
c. Total acreage (project site and any contiguous properties) owned or controlled by the applicant or project sponsor? 281 +/- acres
- c. Is the proposed action an expansion of an existing project or use? Yes No
i. If Yes, what is the approximate percentage of the proposed expansion and identify the units (e.g., acres, miles, housing units, square feet)? % 425 Units: 60.95 acres
- d. Is the proposed action a subdivision, or does it include a subdivision? Yes No
If Yes,
i. Purpose or type of subdivision? (e.g., residential, industrial, commercial; if mixed, specify types)

ii. Is a cluster/conservation layout proposed? Yes No
iii. Number of lots proposed? _____
iv. Minimum and maximum proposed lot sizes? Minimum _____ Maximum _____
- e. Will proposed action be constructed in multiple phases? Yes No
i. If No, anticipated period of construction: N/A* months
ii. If Yes:
 - Total number of phases anticipated _____
 - Anticipated commencement date of phase 1 (including demolition) _____ month _____ year
 - Anticipated completion date of final phase _____ month _____ year
 - Generally describe connections or relationships among phases, including any contingencies where progress of one phase may determine timing or duration of future phases: _____

* As the proposed action involves the production of construction aggregate, the rate at which excavation progresses will be controlled by market demand for the produced product.

f. Does the project include new residential uses? Yes No
 If Yes, show numbers of units proposed.

	<u>One Family</u>	<u>Two Family</u>	<u>Three Family</u>	<u>Multiple Family (four or more)</u>
Initial Phase	_____	_____	_____	_____
At completion	_____	_____	_____	_____
of all phases	_____	_____	_____	_____

g. Does the proposed action include new non-residential construction (including expansions)? Yes No
 If Yes,
 i. Total number of structures _____
 ii. Dimensions (in feet) of largest proposed structure: _____ height; _____ width; and _____ length
 iii. Approximate extent of building space to be heated or cooled: _____ square feet

h. Does the proposed action include construction or other activities that will result in the impoundment of any liquids, such as creation of a water supply, reservoir, pond, lake, waste lagoon or other storage? Yes No
 If Yes,
 i. Purpose of the impoundment: stormwater management
 ii. If a water impoundment, the principal source of the water: Ground water Surface water streams Other specify: Stormwater
 iii. If other than water, identify the type of impounded/contained liquids and their source.
N/A
 iv. Approximate size of the proposed impoundment. Volume: _____ 0.329 million gallons; surface area: _____ 5.2 acres
 v. Dimensions of the proposed dam or impounding structure: _____ N/A height; _____ N/A length
 vi. Construction method/materials for the proposed dam or impounding structure (e.g., earth fill, rock, wood, concrete):
Creation of stormwater pond will use industry-standard excavation practices.

D.2. Project Operations

a. Does the proposed action include any excavation, mining, or dredging, during construction, operations, or both? Yes No
 (Not including general site preparation, grading or installation of utilities or foundations where all excavated materials will remain onsite)
 If Yes:
 i. What is the purpose of the excavation or dredging? The production of aggregate material.
 ii. How much material (including rock, earth, sediments, etc.) is proposed to be removed from the site?
 • Volume (specify tons or cubic yards): 3,500,000 +/- cubic yards
 • Over what duration of time? +/- 20 years, depending on market demand
 iii. Describe nature and characteristics of materials to be excavated or dredged, and plans to use, manage or dispose of them.
Sand and gravel will be produced and sold.
 iv. Will there be onsite dewatering or processing of excavated materials? Yes No
 If yes, describe. Materials will be processed at the existing processing plant in the currently approved life of mine.
 v. What is the total area to be dredged or excavated? _____ 75.28 acres
 vi. What is the maximum area to be worked at any one time? _____ 15 acres
 vii. What would be the maximum depth of excavation or dredging? _____ 80-100 feet
 viii. Will the excavation require blasting? Yes No
 ix. Summarize site reclamation goals and plan: _____
See dEIS and MLUP.

b. Would the proposed action cause or result in alteration of, increase or decrease in size of, or encroachment into any existing wetland, waterbody, shoreline, beach or adjacent area? Yes No
 If Yes:
 i. Identify the wetland or waterbody which would be affected (by name, water index number, wetland map number or geographic description): The pond located on the western edge of the site will be eliminated by the proposed operation; however stormwater runoff will be directed towards the stormwater management area to the east.

ii. Describe how the proposed action would affect that waterbody or wetland, e.g. excavation, fill, placement of structures, or alteration of channels, banks and shorelines. Indicate extent of activities, alterations and additions in square feet or acres:

iii. Will proposed action cause or result in disturbance to bottom sediments? Yes No

If Yes, describe: _____

iv. Will proposed action cause or result in the destruction or removal of aquatic vegetation? Yes No

If Yes:

- acres of aquatic vegetation proposed to be removed: _____
- expected acreage of aquatic vegetation remaining after project completion: _____
- purpose of proposed removal (e.g. beach clearing, invasive species control, boat access): _____

- proposed method of plant removal: _____
- if chemical/herbicide treatment will be used, specify product(s): _____

v. Describe any proposed reclamation/mitigation following disturbance: _____

See dEIS and MLUP. _____

c. Will the proposed action use, or create a new demand for water? Yes No

If Yes:

i. Total anticipated water usage/demand per day: _____ gallons/day

ii. Will the proposed action obtain water from an existing public water supply? Yes No

If Yes:

- Name of district or service area: _____
- Does the existing public water supply have capacity to serve the proposal? Yes No
- Is the project site in the existing district? Yes No
- Is expansion of the district needed? Yes No
- Do existing lines serve the project site? Yes No

iii. Will line extension within an existing district be necessary to supply the project? Yes No

If Yes:

- Describe extensions or capacity expansions proposed to serve this project: _____

- Source(s) of supply for the district: _____

iv. Is a new water supply district or service area proposed to be formed to serve the project site? Yes No

If Yes:

- Applicant/sponsor for new district: _____
- Date application submitted or anticipated: _____
- Proposed source(s) of supply for new district: _____

v. If a public water supply will not be used, describe plans to provide water supply for the project: _____

vi. If water supply will be from wells (public or private), maximum pumping capacity: _____ gallons/minute.

d. Will the proposed action generate liquid wastes? Yes No

If Yes:

i. Total anticipated liquid waste generation per day: _____ gallons/day

ii. Nature of liquid wastes to be generated (e.g., sanitary wastewater, industrial; if combination, describe all components and approximate volumes or proportions of each): _____

iii. Will the proposed action use any existing public wastewater treatment facilities? Yes No

If Yes:

- Name of wastewater treatment plant to be used: _____
- Name of district: _____
- Does the existing wastewater treatment plant have capacity to serve the project? Yes No
- Is the project site in the existing district? Yes No
- Is expansion of the district needed? Yes No

• Do existing sewer lines serve the project site? Yes No
 • Will line extension within an existing district be necessary to serve the project? Yes No
 If Yes:
 • Describe extensions or capacity expansions proposed to serve this project: _____

iv. Will a new wastewater (sewage) treatment district be formed to serve the project site? Yes No
 If Yes:
 • Applicant/sponsor for new district: _____
 • Date application submitted or anticipated: _____
 • What is the receiving water for the wastewater discharge? _____

v. If public facilities will not be used, describe plans to provide wastewater treatment for the project, including specifying proposed receiving water (name and classification if surface discharge, or describe subsurface disposal plans):

vi. Describe any plans or designs to capture, recycle or reuse liquid waste: _____

e. Will the proposed action disturb more than one acre and create stormwater runoff, either from new point sources (i.e. ditches, pipes, swales, curbs, gutters or other concentrated flows of stormwater) or non-point source (i.e. sheet flow) during construction or post construction? Yes No
 If Yes:
 i. How much impervious surface will the project create in relation to total size of project parcel?
 _____ NA Square feet or _____ NA acres (impervious surface)
 _____ NA Square feet or _____ NA acres (parcel size)
 ii. Describe types of new point sources. When the demand is needed, overflow from an emergency spillway will be directed to the Village of Watkins Glen Drainage Easement (Outfall 001).

 iii. Where will the stormwater runoff be directed (i.e. on-site stormwater management facility/structures, adjacent properties, groundwater, on-site surface water or off-site surface waters)?
 A dedicated stormwater management area, where on-site stormwater will be treated. An emergency spillway within the stormwater management area will be constructed to allow runoff to overflow to the Village of Watkins Glen Drainage Easement, when the demand is needed (Outfall 001).
 • If to surface waters, identify receiving water bodies or wetlands: _____
 On-site surface water treatment pond. _____
 • Will stormwater runoff flow to adjacent properties? Yes No

iv. Does proposed plan minimize impervious surfaces, use pervious materials or collect and re-use stormwater? Yes No

f. Does the proposed action include, or will it use on-site, one or more sources of air emissions, including fuel combustion, waste incineration, or other processes or operations? Yes No
 If Yes, identify:
 i. Mobile sources during project operations (e.g., heavy equipment, fleet or delivery vehicles)
 Continued use of bulldozers, scrapers, front-end wheel loaders, haul trucks, and other standard industry equipment. _____
 ii. Stationary sources during construction (e.g., power generation, structural heating, batch plant, crushers)
 N/A _____
 iii. Stationary sources during operations (e.g., process emissions, large boilers, electric generation)
 No new stationary sources are proposed during the operation of the expansion area. _____

g. Will any air emission sources named in D.2.f (above), require a NY State Air Registration, Air Facility Permit, or Federal Clean Air Act Title IV or Title V Permit? Yes No
 If Yes:
 i. Is the project site located in an Air quality non-attainment area? (Area routinely or periodically fails to meet ambient air quality standards for all or some parts of the year) Yes No
 ii. In addition to emissions as calculated in the application, the project will generate:
 • _____ Tons/year (short tons) of Carbon Dioxide (CO₂)
 • _____ Tons/year (short tons) of Nitrous Oxide (N₂O)
 • _____ Tons/year (short tons) of Perfluorocarbons (PFCs)
 • _____ Tons/year (short tons) of Sulfur Hexafluoride (SF₆)
 • _____ Tons/year (short tons) of Carbon Dioxide equivalent of Hydroflouorocarbons (HFCs)
 • _____ Tons/year (short tons) of Hazardous Air Pollutants (HAPs)

h. Will the proposed action generate or emit methane (including, but not limited to, sewage treatment plants, landfills, composting facilities)? Yes No

If Yes:

i. Estimate methane generation in tons/year (metric): _____

ii. Describe any methane capture, control or elimination measures included in project design (e.g., combustion to generate heat or electricity, flaring): _____

i. Will the proposed action result in the release of air pollutants from open-air operations or processes, such as quarry or landfill operations? Yes No

If Yes: Describe operations and nature of emissions (e.g., diesel exhaust, rock particulates/dust):
Dust particles generated from internal transportation and material excavation will be minimized through dust control practices as detailed in the dEIS and MLUP.

j. Will the proposed action result in a substantial increase in traffic above present levels or generate substantial new demand for transportation facilities or services? Yes No

If Yes:

i. When is the peak traffic expected (Check all that apply): Morning Evening Weekend
 Randomly between hours of _____ to _____.

ii. For commercial activities only, projected number of semi-trailer truck trips/day: _____

iii. Parking spaces: Existing _____ Proposed _____ Net increase/decrease _____

iv. Does the proposed action include any shared use parking? Yes No

v. If the proposed action includes any modification of existing roads, creation of new roads or change in existing access, describe:

vi. Are public/private transportation service(s) or facilities available within 1/2 mile of the proposed site? Yes No

vii. Will the proposed action include access to public transportation or accommodations for use of hybrid, electric or other alternative fueled vehicles? Yes No

viii. Will the proposed action include plans for pedestrian or bicycle accommodations for connections to existing pedestrian or bicycle routes? Yes No

k. Will the proposed action (for commercial or industrial projects only) generate new or additional demand for energy? Yes No

If Yes:

i. Estimate annual electricity demand during operation of the proposed action: _____

ii. Anticipated sources/suppliers of electricity for the project (e.g., on-site combustion, on-site renewable, via grid/local utility, or other):

iii. Will the proposed action require a new, or an upgrade to, an existing substation? Yes No

l. Hours of operation. Answer all items which apply.

<p>i. During Construction:</p> <ul style="list-style-type: none"> • Monday - Friday: _____ N/A • Saturday: _____ N/A • Sunday: _____ N/A • Holidays: _____ N/A 	<p>ii. During Operations:</p> <ul style="list-style-type: none"> • Monday - Friday: _____ 6:00 am - 8:00 pm • Saturday: _____ 6:00 am - 8:00 pm • Sunday: _____ Closed • Holidays: _____ Closed
--	---

m. Will the proposed action produce noise that will exceed existing ambient noise levels during construction, operation, or both? Yes No

If yes:

i. Provide details including sources, time of day and duration:
Operation of excavation equipment will conform to the noise levels of existing nearby operations, but may exceed the current ambient noise levels.

ii. Will proposed action remove existing natural barriers that could act as a noise barrier or screen? Yes No
 Describe: Some on-site vegetation will be removed; however, additional topographic barriers will be established. For further detail, see dEIS.

n. Will the proposed action have outdoor lighting? Yes No

If yes:

i. Describe source(s), location(s), height of fixture(s), direction/aim, and proximity to nearest occupied structures:

ii. Will proposed action remove existing natural barriers that could act as a light barrier or screen? Yes No
 Describe: _____

o. Does the proposed action have the potential to produce odors for more than one hour per day? Yes No
 If Yes, describe possible sources, potential frequency and duration of odor emissions, and proximity to nearest occupied structures: _____

p. Will the proposed action include any bulk storage of petroleum (combined capacity of over 1,100 gallons) or chemical products 185 gallons in above ground storage or any amount in underground storage? Yes No

If Yes:

i. Product(s) to be stored _____

ii. Volume(s) _____ per unit time _____ (e.g., month, year)

iii. Generally describe proposed storage facilities: _____

q. Will the proposed action (commercial, industrial and recreational projects only) use pesticides (i.e., herbicides, insecticides) during construction or operation? Yes No

If Yes:

i. Describe proposed treatment(s):

ii. Will the proposed action use Integrated Pest Management Practices? Yes No

r. Will the proposed action (commercial or industrial projects only) involve or require the management or disposal of solid waste (excluding hazardous materials)? Yes No

If Yes:

i. Describe any solid waste(s) to be generated during construction or operation of the facility:

- Construction: _____ tons per _____ (unit of time)
- Operation : _____ tons per _____ (unit of time)

ii. Describe any proposals for on-site minimization, recycling or reuse of materials to avoid disposal as solid waste:

- Construction: _____
- Operation: _____

iii. Proposed disposal methods/facilities for solid waste generated on-site:

- Construction: _____
- Operation: _____

c. Is the project site presently used by members of the community for public recreation? Yes No
i. If Yes: explain: _____

d. Are there any facilities serving children, the elderly, people with disabilities (e.g., schools, hospitals, licensed day care centers, or group homes) within 1500 feet of the project site? Yes No
If Yes,
i. Identify Facilities:

e. Does the project site contain an existing dam? Yes No
If Yes:
i. Dimensions of the dam and impoundment:
• Dam height: _____ feet
• Dam length: _____ feet
• Surface area: _____ acres
• Volume impounded: _____ gallons OR acre-feet
ii. Dam's existing hazard classification: _____
iii. Provide date and summarize results of last inspection:

f. Has the project site ever been used as a municipal, commercial or industrial solid waste management facility, or does the project site adjoin property which is now, or was at one time, used as a solid waste management facility? Yes No
If Yes:
i. Has the facility been formally closed? Yes No
• If yes, cite sources/documentation: _____
ii. Describe the location of the project site relative to the boundaries of the solid waste management facility:

iii. Describe any development constraints due to the prior solid waste activities: _____

g. Have hazardous wastes been generated, treated and/or disposed of at the site, or does the project site adjoin property which is now or was at one time used to commercially treat, store and/or dispose of hazardous waste? Yes No
If Yes:
i. Describe waste(s) handled and waste management activities, including approximate time when activities occurred:

h. Potential contamination history. Has there been a reported spill at the proposed project site, or have any remedial actions been conducted at or adjacent to the proposed site? Yes No
If Yes:
i. Is any portion of the site listed on the NYSDEC Spills Incidents database or Environmental Site Remediation database? Check all that apply: Yes No
 Yes – Spills Incidents database Provide DEC ID number(s): _____
 Yes – Environmental Site Remediation database Provide DEC ID number(s): _____
 Neither database
ii. If site has been subject of RCRA corrective activities, describe control measures: _____
iii. Is the project within 2000 feet of any site in the NYSDEC Environmental Site Remediation database? Yes No
If yes, provide DEC ID number(s): 849002, 849003, C849004
iv. If yes to (i), (ii) or (iii) above, describe current status of site(s):
849002 and C849004 - part of the Seneca Market 1, LLC BCP, a certificate of completion was issued on December 31, 2008.
849003 - Sciorie's Dry Cleaners - Residual PCE contamination in soil, groundwater, soil vapor and indoor air is being managed under a Site Management Plan.

v. Is the project site subject to an institutional control limiting property uses? Yes No

- If yes, DEC site ID number: _____
- Describe the type of institutional control (e.g., deed restriction or easement): _____
- Describe any use limitations: _____
- Describe any engineering controls: _____
- Will the project affect the institutional or engineering controls in place? Yes No
- Explain: _____

E.2. Natural Resources On or Near Project Site

a. What is the average depth to bedrock on the project site? _____ 30-140 feet

b. Are there bedrock outcroppings on the project site? Yes No
 If Yes, what proportion of the site is comprised of bedrock outcroppings? _____ %

c. Predominant soil type(s) present on project site:

HSD:Howard soils, moderately steep	_____	58 %
VaC:Valois gravelly silt loam	_____	23 %
HrB: Howard gravelly loam	_____	14 %

d. What is the average depth to the water table on the project site? Average: _____ >6 feet

e. Drainage status of project site soils: Well Drained: _____ 99 % of site
 Moderately Well Drained: _____ 1 % of site
 Poorly Drained _____ % of site

f. Approximate proportion of proposed action site with slopes: 0-10%: _____ 75 % of site
 10-15%: _____ 25 % of site
 15% or greater: _____ % of site

g. Are there any unique geologic features on the project site? Yes No
 If Yes, describe: _____

h. Surface water features.

i. Does any portion of the project site contain wetlands or other waterbodies (including streams, rivers, ponds or lakes)? Yes No

ii. Do any wetlands or other waterbodies adjoin the project site? Yes No

If Yes to either *i* or *ii*, continue. If No, skip to E.2.i.

iii. Are any of the wetlands or waterbodies within or adjoining the project site regulated by any federal, state or local agency? Yes No

iv. For each identified regulated wetland and waterbody on the project site, provide the following information:

- Streams: Name 898-451 Quarter Mile Creek, 898-443.1 Glen Creek Classification C, B
- Lakes or Ponds: Name _____ Classification _____
- Wetlands: Name NWI-mapped waterbodies Approximate Size 0.52 acres
- Wetland No. (if regulated by DEC) _____

v. Are any of the above water bodies listed in the most recent compilation of NYS water quality-impaired waterbodies? Yes No
 If yes, name of impaired water body/bodies and basis for listing as impaired: _____

i. Is the project site in a designated Floodway? Yes No

j. Is the project site in the 100 year Floodplain? Yes No

k. Is the project site in the 500 year Floodplain? Yes No

l. Is the project site located over, or immediately adjoining, a primary, principal or sole source aquifer? Yes No
 If Yes:
 i. Name of aquifer: _____

<p>m. Identify the predominant wildlife species that occupy or use the project site: _____</p> <p>Small mammals (i.e., squirrel, chipmunk) _____</p> <p>common birds (sparrow, finch, etc.) _____</p> <p>deer _____</p>	
<p>n. Does the project site contain a designated significant natural community? <input type="checkbox"/> Yes <input checked="" type="checkbox"/> No</p> <p>If Yes:</p> <p style="margin-left: 20px;">i. Describe the habitat/community (composition, function, and basis for designation): _____</p> <p style="margin-left: 20px;">ii. Source(s) of description or evaluation: _____</p> <p style="margin-left: 20px;">iii. Extent of community/habitat:</p> <ul style="list-style-type: none"> • Currently: _____ acres • Following completion of project as proposed: _____ acres • Gain or loss (indicate + or -): _____ acres 	
<p>o. Does project site contain any species of plant or animal that is listed by the federal government or NYS as endangered or threatened, or does it contain any areas identified as habitat for an endangered or threatened species? <input type="checkbox"/> Yes <input checked="" type="checkbox"/> No</p>	
<p>p. Does the project site contain any species of plant or animal that is listed by NYS as rare, or as a species of special concern? <input checked="" type="checkbox"/> Yes <input type="checkbox"/> No</p> <p>USFWS identified Leedy's Roseroot as having potential to occur near the project vicinity; however according to the NYNHP, there are no documented occurrences on-site- only one documented special concern species within the Watkins Glen State Park boundaries: Gray Petaltail, Tachopteryx thoreyi. See dEIS for further details and applicable documentation.</p>	
<p>q. Is the project site or adjoining area currently used for hunting, trapping, fishing or shell fishing? <input type="checkbox"/> Yes <input checked="" type="checkbox"/> No</p> <p>If yes, give a brief description of how the proposed action may affect that use: _____</p> <p>_____</p>	
E.3. Designated Public Resources On or Near Project Site	
<p>a. Is the project site, or any portion of it, located in a designated agricultural district certified pursuant to Agriculture and Markets Law, Article 25-AA, Section 303 and 304? <input type="checkbox"/> Yes <input checked="" type="checkbox"/> No</p> <p>If Yes, provide county plus district name/number: _____</p>	
<p>b. Are agricultural lands consisting of highly productive soils present? <input type="checkbox"/> Yes <input checked="" type="checkbox"/> No</p> <p style="margin-left: 20px;">i. If Yes: acreage(s) on project site? _____</p> <p style="margin-left: 20px;">ii. Source(s) of soil rating(s): _____</p>	
<p>c. Does the project site contain all or part of, or is it substantially contiguous to, a registered National Natural Landmark? <input type="checkbox"/> Yes <input checked="" type="checkbox"/> No</p> <p>If Yes:</p> <p style="margin-left: 20px;">i. Nature of the natural landmark: <input type="checkbox"/> Biological Community <input type="checkbox"/> Geological Feature</p> <p style="margin-left: 20px;">ii. Provide brief description of landmark, including values behind designation and approximate size/extent: _____</p> <p>_____</p> <p>_____</p>	
<p>d. Is the project site located in or does it adjoin a state listed Critical Environmental Area? <input type="checkbox"/> Yes <input checked="" type="checkbox"/> No</p> <p>If Yes:</p> <p style="margin-left: 20px;">i. CEA name: _____</p> <p style="margin-left: 20px;">ii. Basis for designation: _____</p> <p style="margin-left: 20px;">iii. Designating agency and date: _____</p>	

e. Does the project site contain, or is it substantially contiguous to, a building, archaeological site, or district which is listed on, or has been nominated by the NYS Board of Historic Preservation for inclusion on, the State or National Register of Historic Places? Yes No

If Yes:
 i. Nature of historic/archaeological resource: Archaeological Site Historic Building or District
 ii. Name: See Table 2: Inventory of Aesthetic Resources included in the dEIS (see Visual Impact Assessment.)
 iii. Brief description of attributes on which listing is based:
 See Table 2: Inventory of Aesthetic Resources included in the dEIS (see Visual Impact Assessment).

f. Is the project site, or any portion of it, located in or adjacent to an area designated as sensitive for archaeological sites on the NY State Historic Preservation Office (SHPO) archaeological site inventory? Yes No

g. Have additional archaeological or historic site(s) or resources been identified on the project site? Yes No
 If Yes:
 i. Describe possible resource(s):
 ii. Basis for identification:

h. Is the project site within five miles of any officially designated and publicly accessible federal, state, or local scenic or aesthetic resource? Yes No
 If Yes:
 i. Identify resource: See Table 2: Inventory of Aesthetic Resources included in the Visual Impact Assessment
 ii. Nature of, or basis for, designation (e.g., established highway overlook, state or local park, state historic trail or scenic byway, etc.): *Watkins Glen State Park
 iii. Distance between project and resource: 0.25 miles. *Project is adjacent to lands owned by the State that include the Park.

i. Is the project site located within a designated river corridor under the Wild, Scenic and Recreational Rivers Program 6 NYCRR 666? Yes No
 If Yes:
 i. Identify the name of the river and its designation:
 ii. Is the activity consistent with development restrictions contained in 6NYCRR Part 666? Yes No

F. Additional Information

Attach any additional information which may be needed to clarify your project.

If you have identified any adverse impacts which could be associated with your proposal, please describe those impacts plus any measures which you propose to avoid or minimize them.

G. Verification

I certify that the information provided is true to the best of my knowledge.

Applicant/Sponsor Name Martin Wojcik Date 9/14/21

X Signature  Title Owner